



SDD ES EIP

PILZ
THE SPIRIT OF SAFETY

- ▶ PSEN sensor technology

This document is the original document.

All rights to this documentation are reserved by Pilz GmbH & Co. KG. Copies may be made for the user's internal purposes. Suggestions and comments for improving this documentation will be gratefully received.

Source code from third-party manufacturers or open source software has been used for some components. The relevant licence information is available on the Internet on the Pilz homepage.

Pilz®, PIT®, PMI®, PNOZ®, Primo®, PSEN®, PSS®, PVIS®, SafetyBUS p®, SafetyEYE®, SafetyNET p®, the spirit of safety® are registered and protected trademarks of Pilz GmbH & Co. KG in some countries.



SD means Secure Digital

Introduction	5
Validity of documentation	5
Using the documentation	5
Definition of symbols	5
Overview	6
Scope of supply	6
Unit features	6
Front view	7
Safety	8
Intended use	8
Safety regulations	8
Additional documents that apply	8
Use of qualified personnel	9
Warranty and liability	9
Disposal	9
Security	9
Implemented security measures	10
Required security measures	10
Function description	11
Operation	11
Data structure	12
Block diagram	12
Installation	13
Commissioning	13
General wiring guidelines	13
Ethernet interfaces	13
RJ45 interfaces ("Ethernet")	13
Requirements of the connection cable and connector	14
Interface configuration	14
RJ45 connection cable	14
Process data exchange	15
System structure	16
Set IP address	16
Operation	17
Display	18
Structure	18
Operate menu	20
Menu structure	20
Menu settings	21
Device History menu	22
Device Info menu	23

Device Event menu	24
Web server	24
Dimensions in mm	29
Tecnical details	30
Supplementary data	32
Network data	32
Order reference	32
Product	32
Accessories	32
EC declaration of conformity	33

Introduction

Validity of documentation

This documentation is valid for the product SDD ES EIP. It is valid until new documentation is published.

This operating manual explains the function and operation, describes the installation and provides guidelines on how to connect the product.

Using the documentation

This document is intended for instruction. Only install and commission the product if you have read and understood this document. The document should be retained for future reference.

Definition of symbols

Information that is particularly important is identified as follows:



DANGER!

This warning must be heeded! It warns of a hazardous situation that poses an immediate threat of serious injury and death and indicates preventive measures that can be taken.



WARNING!

This warning must be heeded! It warns of a hazardous situation that could lead to serious injury and death and indicates preventive measures that can be taken.



CAUTION!

This refers to a hazard that can lead to a less serious or minor injury plus material damage, and also provides information on preventive measures that can be taken.



NOTICE

This describes a situation in which the product or devices could be damaged and also provides information on preventive measures that can be taken. It also highlights areas within the text that are of particular importance.



INFORMATION

This gives advice on applications and provides information on special features.

Overview

Scope of supply

- ▶ Fieldbus module SDD ES EIP

Unit features

SDD ES EIP is an active subscriber (Master) of Safety Device Diagnostics

- ▶ Backlit display
- ▶ LEDs for
 - Supply voltage
 - Fieldbus interface
 - Safety states and diagnostic information for the safety devices
 - Error
- ▶ Multifunction switch for menu control
- ▶ Plug-in connection terminals:
Either spring-loaded terminal or screw terminal available as an accessory (see Order references for accessories).
- ▶ 6 contacts that can be used as input contacts and/or output contacts (GPIO)

Front view

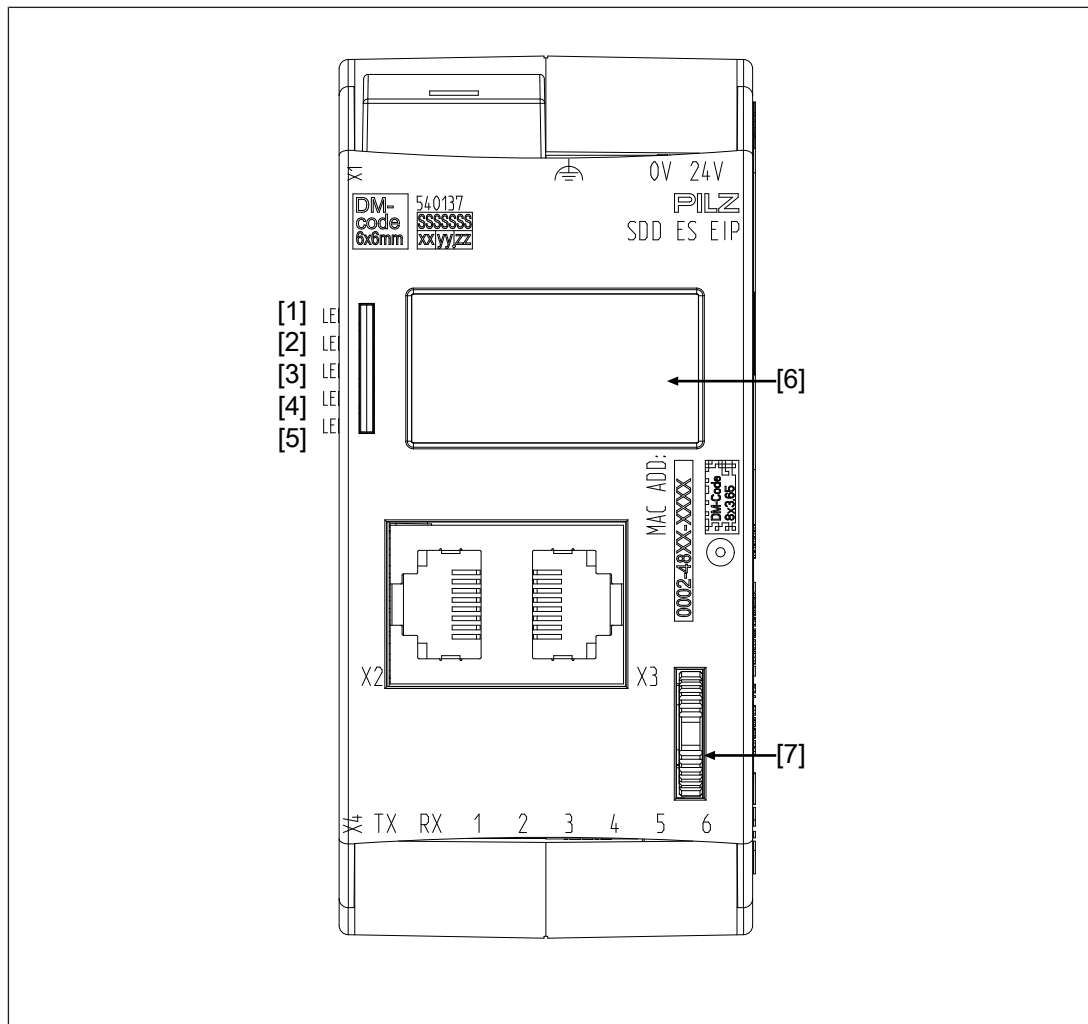

Legend

- X1 ▶ Supply voltage 0 V, 24 V
 - ▶ Functional earth
- X2/X3 Ethernet interfaces
- X4 ▶ TX: Output for connecting the signal input of the safety devices
 - ▶ RX: Input for connecting the signal output of the safety devices
 - ▶ 1 – 6: Configurable inputs/outputs for connecting signal inputs/outputs from additional devices (not incorporated in Safety Device Diagnostics)
- [1] LED Power
- [2] LED EtherNet/IP
- [3] LED Devices
- [4] LED Start up
- [5] LED Fault
- [6] Display
- [7] Multifunction switch

Safety

Intended use

The SDD ES EIP is used for communication between connected safety devices and the EtherNet/IP (TM). The EtherNet/IP (TM) is designed for data exchange at field level. The SDD ES EIP operates as the Server; a connected control system operates as the Client.

Application of the product SDD ES EIP:

- ▶ Evaluate and display diagnostic data and status information from safety devices
- ▶ Connect safety devices and EtherNet/IP (TM)
- ▶ Processing and display of safety device data
- ▶ Transfer diagnostic data and status information from the safety devices to EtherNet/IP (TM)

Appropriate safety devices are listed in the document "System Description Safety Device Diagnostics".

The SDD ES EIP may not be used for safety-related functions.

Safety-related functions of the safety devices have to be evaluated separately by a safe evaluation device.

The following is deemed improper use in particular

- ▶ Any component, technical or electrical modification to the product,
- ▶ Use of the product outside the areas described in this manual,
- ▶ Use of the product outside the technical details (see [Technical details](#)  30).



NOTICE

EMC-compliant electrical installation

The product is designed for use in an industrial environment. The product may cause interference if installed in other environments. If installed in other environments, measures should be taken to comply with the applicable standards and directives for the respective installation site with regard to interference.

Safety regulations

Additional documents that apply

Please read and take note of the following documents:

- ▶ Operating manual for the relevant Pilz safety device
- ▶ Operating manual of a passive junction, for example:
 - PSEN ix2 F4 code
 - PSEN ix2 F8 code
 - PDP67 F 4 code
 - PSEN Y junction

▶ System description "Safety Device Diagnostics"

You will need to be conversant with the information in these documents in order to fully understand this operating manual.

Use of qualified personnel

The products may only be assembled, installed, programmed, commissioned, operated, maintained and decommissioned by persons who are competent to do so.

A competent person is a qualified and knowledgeable person who, because of their training, experience and current professional activity, has the specialist knowledge required. To be able to inspect, assess and operate devices, systems and machines, the person has to be informed of the state of the art and the applicable national, European and international laws, directives and standards.

It is the company's responsibility only to employ personnel who

- ▶ Are familiar with the basic regulations concerning health and safety / accident prevention,
- ▶ Have read and understood the information provided in the section entitled Safety
- ▶ Have a good knowledge of the generic and specialist standards applicable to the specific application.

Warranty and liability

All claims to warranty and liability will be rendered invalid if

- ▶ The product was used contrary to the purpose for which it is intended,
- ▶ Damage can be attributed to not having followed the guidelines in the manual,
- ▶ Operating personnel are not suitably qualified,
- ▶ Any type of modification has been made (e.g. exchanging components on the PCB boards, soldering work etc.).

Disposal

- ▶ When decommissioning, please comply with local regulations regarding the disposal of electronic devices (e.g. Electrical and Electronic Equipment Act).

Security

To secure plants, systems, machines and networks against cyberthreats it is necessary to implement (and continuously maintain) an overall industrial security concept that is state of the art.

Perform a risk assessment in accordance with VDI/VDE 2182 or IEC 62443-3-2 and plan the security measures with care. If necessary, seek advice from Pilz Customer Support.

Implemented security measures

- ▶ The web application is protected against unauthorised access by a password prompt.
- ▶ The password is saved in an encrypted format.
- ▶ If a password is changed, you will be prompted to enter the old password for authentication.
- ▶ A user will automatically be logged out of the web application after a session duration of 24 hours.
- ▶ Defend against CSRF attacks (Cross-Site Request Forgery) by assigning a unique token to a session.

Required security measures

- ▶ The product is not protected from physical manipulation or from reading of memory contents during physical access. We therefore recommend that you install the product in a lockable control cabinet.
- ▶ The configuration computer that accesses the product has to be protected from attacks by a firewall or other suitable measures. We recommend that a virus scanner is used on this configuration computer and updated regularly.
- ▶ Ensure that the product is separated by a router (layer 3 switch or firewall) from the company network.

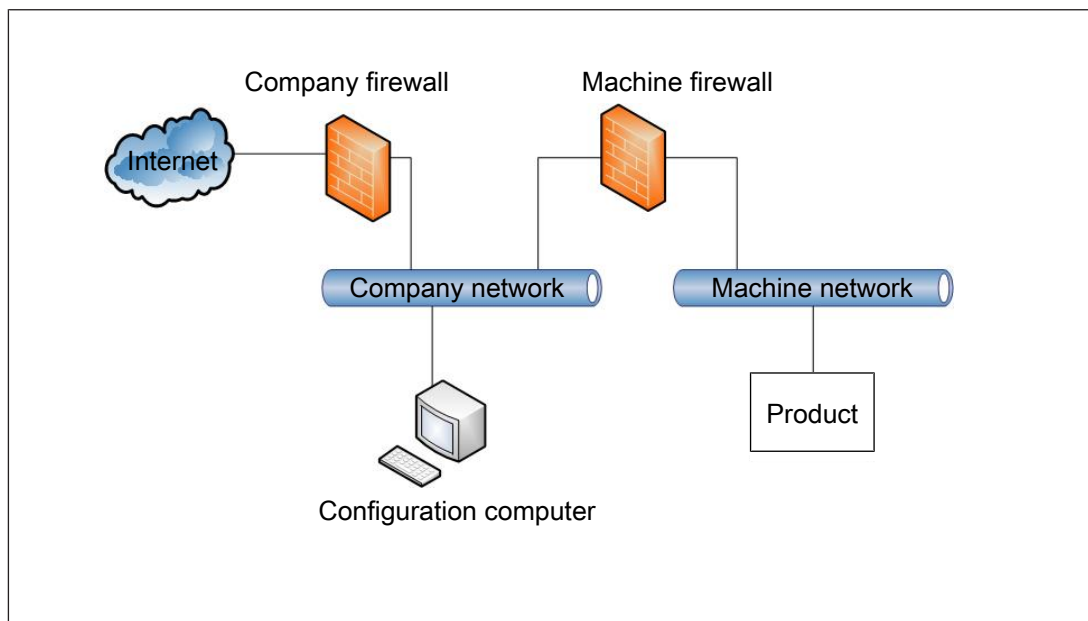

Fig.: Example network topology

- ▶ If necessary, protect the configuration computer and the product from unauthorised use by assigning passwords and taking further measures if required. We also recommend that the user logged on to this configuration computer does not have administrator rights.
- ▶ Assign only safe passwords. When assigning passwords, please note:
 - The password should have at least 8 characters.
 - The password should contain upper and lower case characters, as well as special characters and numbers.
 - If possible, the password should not be available in dictionaries.

- The password should not be made up of standard variants and repetitions or keyboard patterns (so not: 1234abcd).
- Use a password manager for optimum management of complex passwords.
- Language-dependent characters are not available in every keyboard language.
- Make sure you regularly change the passwords of the user accounts on the system or ask the users to change their passwords themselves.
- Make the users aware of the responsible use of their access data.
- ▶ Assign different permissions for the various user groups (e.g. diagnostics - configuration).
- ▶ As soon as possible, install firmware updates that Pilz provides for the product.
- ▶ Before disposal, the product must be securely decommissioned. To do this, all the data must be deleted from the device.
 - Set the configuration back to its default settings or delete the configuration.
 - Switch off the product.
- ▶ Note the network data for risk analysis and the security measures.

Function description

Operation

The SDD ES EIP is configured and started automatically after the supply voltage is switched on.

LEDs indicate the status of the SDD ES EIP and communication between the safety devices and EtherNet/IP Master.

The SDD ES EIP sends telegrams to the connected safety devices via a ring protocol.

The following types of data are transferred to the fieldbus and read in.

- ▶ Process data
 - Information and commands on safety functions (OSSD, guard locking, ...)
- ▶ Device data
 - Material number, serial number, product version, actuator ID, ...
- ▶ Configuration data
 - Behaviour of the control of safety devices with guard locking (control of the guard locking via SDD can be switched on and off on PROFINET, EtherNET/IP and ETH using Autoinit)

Communication with connected control systems or control elements is via the bus interface EtherNet/IP (TM).

The IP address is set on the display with the multifunction switch.

Data structure

The input and output data is divided into the following data areas:

- ▶ Data for the overall system and for the SDD ES EIP
- ▶ Data for the connected safety devices
- ▶ List of specified changes of state and events
- ▶ Control system telegrams for the safety devices and responses from the safety devices

The data structure, including a list of the possible events, is described in detail in the System Description "Safety Device Diagnostics".

Block diagram

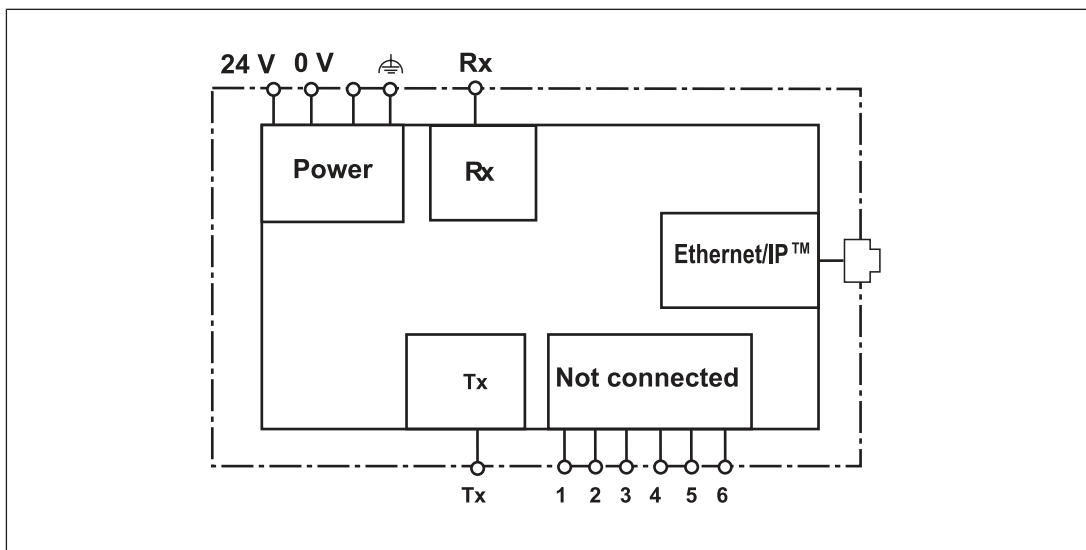

Installation

- ▶ The safety relay should be installed in a control cabinet with a protection type of at least IP54.
- ▶ Use the notch on the rear of the unit to attach it to a DIN rail (35 mm).
- ▶ When installed vertically: Secure the unit by using a fixing element (e.g. retaining bracket or end angle).
- ▶ Push the device upwards or downwards before lifting it from the DIN rail.



NOTICE



Damage due to electrostatic discharge!

Electrostatic discharge can damage components. Ensure against discharge before touching the product, e.g. by touching an earthed, conductive surface or by wearing an earthed armband.

Commissioning

General wiring guidelines

Please note:

- ▶ Information given in the [Technical details](#)  30] must be followed.
- ▶ Use copper wiring with a temperature stability of 75 °C.
- ▶ External measures must be used to connect the  terminal to the functional earth.
- ▶ The device must be supplied from the same power supply as the connected safety devices.
- ▶ The power supply must meet the regulations for extra low voltages with protective electrical separation (SELV, PELV).

Ethernet interfaces

RJ45 interfaces ("Ethernet")

Two free switch ports are provided as Ethernet interfaces via an internal autosensing switch. The autosensing switch automatically detects whether data transfer is occurring at 10 Mbit/s or 100 Mbit/s.



INFORMATION

The connected subscribers must support the autosensing/autonegotiation function. If not, the communication partner must be set permanently to "10 Mbit/s, half duplex".

The switch's automatic crossover function means there is no need to distinguish on the connection cable between patch cable (uncrossed data line connection) and crossover cable (crossover data line connection). The switch automatically creates the correct data line connection internally. Patch cable can therefore be used as the connection cable for end devices as well as cascading.

Both Ethernet interfaces use RJ45 technology.

Requirements of the connection cable and connector

The following minimum requirements must be met:

- ▶ Ethernet standards (min. Category 5) 10BaseT or 100BaseTX
- ▶ Double-shielded twisted pair cable for industrial Ethernet use
- ▶ Shielded RJ45 connectors (industrial connectors)

Interface configuration

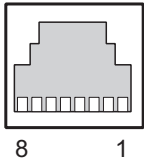
RJ45 socket 8-pin	PIN	Standard	Crossover
	1	TD+ (Transmit+)	RD+ (Receive+)
	2	TD- (Transmit-)	RD- (Receive-)
	3	RD+ (Receive+)	TD+ (Transmit+)
	4	n.c.	n.c.
	5	n.c.	n.c.
	6	RD- (Receive-)	TD- (Transmit-)
	7	n.c.	n.c.
	8	n.c.	n.c.

RJ45 connection cable

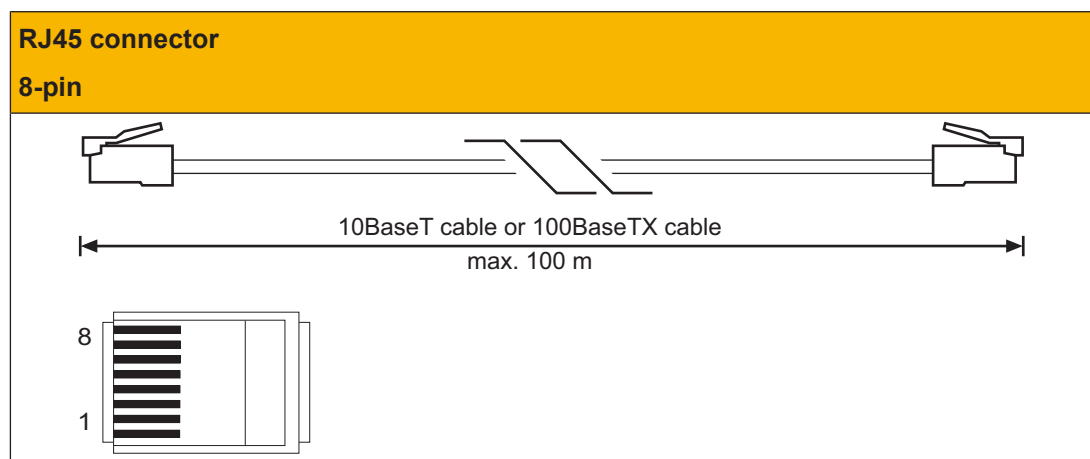

**NOTICE**

With the plug-in connection please note that the data cable and connector have a limited mechanical load capacity. Appropriate design measures should be used to ensure that the plug-in connection is insensitive to increased mechanical stress (e.g. through shock, vibration). Such measures include fixed routing with strain relief, for example.

Process data exchange

The RJ45 interfaces on the internal autosensing switch enable process data to be exchanged with other Ethernet subscribers within a network.

The product SDD ES EIP can also be connected to Ethernet via a hub (hub or switch).

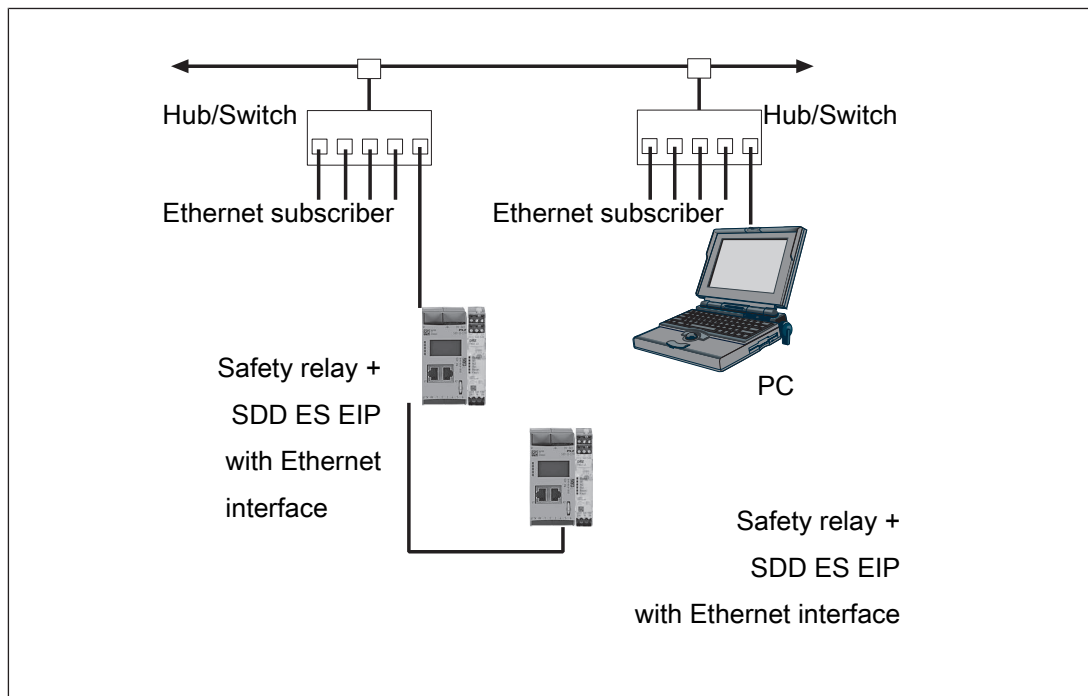

System structure

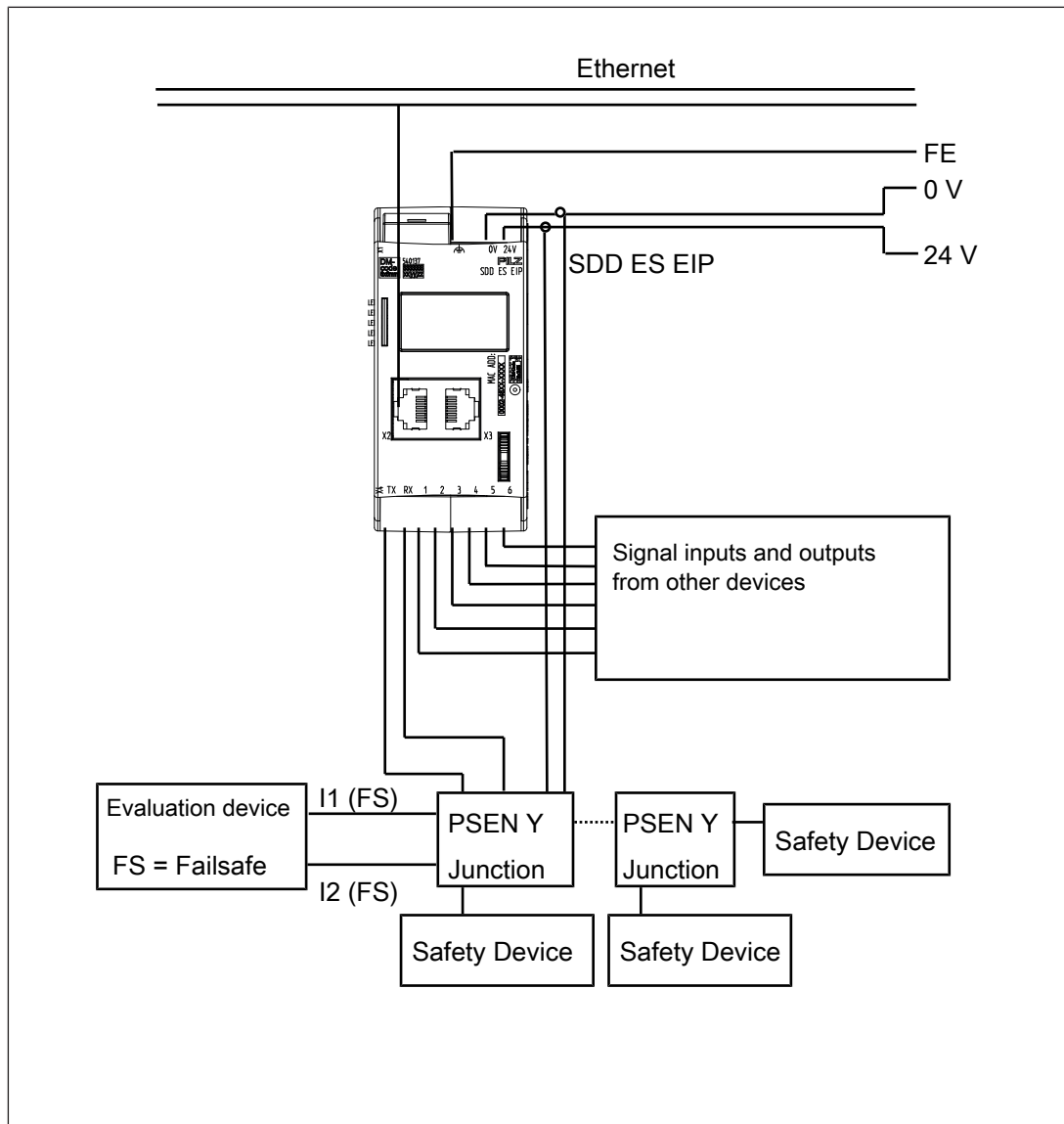

Set IP address

When setting the IP address, please note:

- ▶ The IP address for the fieldbus module SDD ES EIP should not be the same as the PC's IP address.

Obtain IP address automatically via DHCP Server

The IP address can be assigned automatically via a DHCP Server

In order to do this, DHCP must be activated on the fieldbus module SDD ES EIP.

- ▶ DHCP is already activated when the module is delivered. The IP address is obtained automatically from the DHCP server. The module waits to receive an address from a DHCP Server.

Setting the IP address via multifunction switch



IP address is set using the multifunction switch on the front of the SDD ES EIP:













- ▶ The first three bytes of the IP address are: 192.168.1.
- ▶ Subnet mask: 255.255.255.0.
- ▶ The last byte of the IP address is configured using the multifunction switch (value range: 1 ...254).
- ▶ The IP address that is set at the multifunction switch is used. DHCP is therefore disabled.

Operation

The SDD ES EIP is ready for operation when the "Power" LED is lit and the "Fault" LED is unlit.

Legend

-  LED on
-  LED flashes
-  LED off

LED	State		Meaning / action
Power			Supply voltage is outside the permitted range (see Technical details [30])
		Green	Supply voltage is present
EtherNet/IP			No access via the bus connection
		Green	Access via the bus connection
Devices		Green	All connected devices are enabled
			At least one connected device is not enabled
Start up			Normal operation
		Yellow	Device data is being polled
Fault			Normal operation
		Red	Fault on the SDD ES EIP. Check the supply voltage, wiring and configuration of the SDD ES EIP. The system continues to attempt to poll the connected sensors and to create a full list of the connected sensors. In the web server, therefore, the status in Device Info displays "Initializing" and a yellow status bar alternately "Error Handling" and a red status bar.
			Internal fault on the SDD ES EIP Remedy: Replace the device
L/A  	Status of bus connection: No connection		

LED	State	Meaning / action
MS <input type="checkbox"/> <input type="checkbox"/>	●	No supply voltage at the SDD ES EIP
	☀	Green The fieldbus module SDD ES EIP is operating correctly
	●☀	Green The fieldbus module SDD ES EIP is not configured
	☀	Red Recoverable fault
	●☀	Red Major internal error (not recoverable)
NS <input type="checkbox"/> <input type="checkbox"/>	●	No supply voltage present or no IP address assigned
	☀	Green The fieldbus module SDD ES EIP has established at least one connection
	●☀	Green The fieldbus module SDD ES EIP has no IP connection
	☀	Red IP address is already in use
	●☀	Red The connection to the master was interrupted. Remedy: Reconnect.

Display

Structure

The LC display has five lines. Information can be shown and settings can be made on the display.

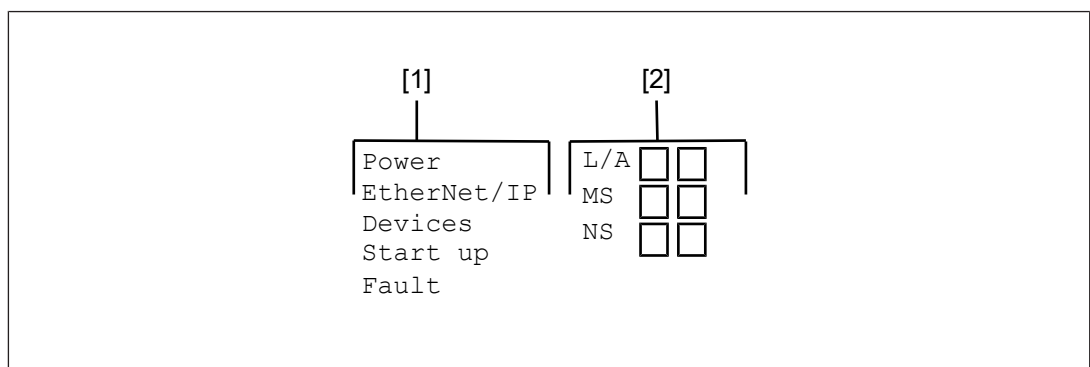

Legend

[1] LED indicators

[2] Status of the bus connection, operating options in the menus

Information on the connection and instructions for the menu settings are displayed in the field in the top right of the display:

Display	Meaning	
L/A <input type="checkbox"/> <input type="checkbox"/>	Status of bus connection: No connection	
MS <input type="checkbox"/> <input type="checkbox"/>	●	No supply voltage at the SDD ES EIP
	☀	Green The fieldbus module SDD ES EIP is operating correctly
	●☀	Green The fieldbus module SDD ES EIP is not configured
	☀	Red Recoverable fault
	●☀	Red Major internal error (not recoverable)
NS <input type="checkbox"/> <input type="checkbox"/>	●	No supply voltage present or no IP address assigned
	☀	Green The fieldbus module SDD ES EIP has established at least one connection
	●☀	Green The fieldbus module SDD ES EIP has no IP connection
	☀	Red IP address is already in use
	●☀	Red The connection to the master was interrupted. Remedy: Reconnect.

Press the multifunction switch to switch to the first menu level.

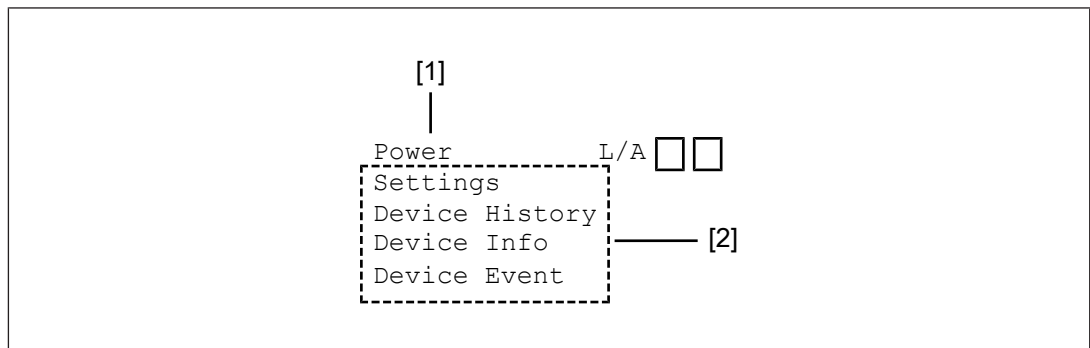

Legend

- [1] Display of LED supply voltage
- [2] Display of menu levels

Operate menu

The menu settings are made on the device's display via a multifunction switch. You can switch between the menu levels by pressing or rotating the multifunction switch.

Press multifunction switch



- ▶ Confirm selection/setting
- ▶ Switch to sub-menu
- ▶ Exit menu: <- **Back**

Rotate multifunction switch up or down



- ▶ Switch menu entries or display potential values

Menu structure

The LC display has a max. five lines.

It displays information and navigates the menu.

The status of the supply voltage is displayed in the first line, followed by 4 lines containing the menu levels.

Menu	Description
Settings	Information about I/O mapping on the connected safety devices and about the network configuration of the SDD ES EIP
Device History	Information about previous changes of state (enables and guard locking) of a connected safety device and status information
Device Info	Information about the connected safety devices
Device Event	Message on the change of state of a safety device

Menu settings

GPIO-Mapping

Value range	Meaning
PLC	Value is set by control system
1-16	1-16 represents a connected safety device. If the actuator enable is set for this safety device, the GPIO is set to 24 V. If the value \neq PLC, the control system has no access to the input/output channel.

IP Config.

Option	Value range	Meaning
DHCP	On / Off	DHCP status (status when delivered = On) Changes will only take effect when SDD ES EIP is restarted.
IP Address	xxx.xxx.xxx.xxx	Display or change the set IP address (xxx = 1 to 255) Changes will only take effect when SDD ES EIP is restarted.
Netmask	255.255.255.xxx	Display or change the set subnet mask Changes will only take effect when SDD ES EIP is restarted.
Gateway Addr.	xxx.xxx.xxx.xxx	Display or change the set Gateway address Changes will only take effect when SDD ES EIP is restarted.
Restart		Trigger a restart of the SDD ES EIP in order to adopt the amended IP configuration settings.

Info

Option	Meaning
IP Address:	Current IP address setting
Ver:	Product version
SVN:	Software version
SN:	Serial number of safety device

Reset Passwords

Option	Meaning
Confirm Reset No Yes	The password for the Settings area can be reset to the password supplied when delivered. ▶ Select Yes to reset the password ▶ Select No to retain the password

Lock Autoinit

Option	Meaning
	Options for the control of the guard locking activation. The setting can also be made via a fieldbus register.
Set to No	Guard locking activation up to the first command via fieldbus using safety outputs of the safety control system
Set to Yes	Guard locking activation only via Safety Device Diagnostics

Device History menu

Device History

Option	Value range	Meaning
Status		Display of message number. The message number is incremented up to 150. Then the oldest messages are overwritten. All message numbers are deleted by switching off the supply voltage.
Device	1-16	Number of device
Safety Gate	◆	Actuator is within the response range
	◇	Actuator is not within the response range
⌚ in sec		Time at which the safety gate was opened (seconds since power-on)
Lock	◆	Guard locking activation
	◇	Guard locking activation

Device Info menu

Device Info

Option	Value range	Meaning
◆ ◆		Number of safety devices (Safety Gate) = Number of diamonds represented State of safety devices (Safety Gate enable):
	◆	Ready
	◇	Not available
◆ ◆		Number of safety devices (guard locking) = Number of diamonds represented State of the safety devices (guard locking):
	◆	activated
	◇	deactivated
I/O	◆◆◆◆◆	State of the configurable inputs/outputs
Device n/x	1/1 – 16/16	Device n of x connected devices

Device n/x

Option	Value range	Meaning
xxx	Max. 16 characters (letters, numbers and special characters)	Equipment identifier (on a fieldbus module with web server)
Coded Switch	e.g. coded switch	Information about device type ^(*)
Ready	◆ / ◇	Status of safety device
		◆ Ready
		◇ Not available
Safety Gate	◆ / ◇	Status of safety gate
		◆ Actuator within the response range
		◇ Actuator not within the response range
Lock	◆ / ◇	Status of guard locking
		◆ activated
		◇ deactivated
OSSD1	◆ / ◇	Status of OSSD1
		◆ ON state
		◇ OFF state
OSSD2	◆ / ◇	Status of OSSD2
		◆ ON state
		◇ OFF state
INPUT1	◆ / ◇	Status Input 1

Option	Value range	Meaning
INPUT2	◆ / ◇	Status Input 2
Coding	C, F, U	Pilz coding type ^(*) C = coded, F = fully coded, U = uniquely fully coded
TeachIn free	1-8	Number of teach-in processes remaining ^(*)
Temp °C		Temperature of a safety device in °C. The temperature of one safety device is updated every two minutes; with 16 safety devices, for example, the temperature of the first safety device is updated every 32 minutes.
Act.#		Actuator short name
Ident#		Material number of safety device ^(*)
SN#		Serial number of safety device ^(*)

^(*) Value on restart

Device Event menu

Device Event

Option	Meaning
Event Nr. x	Display of consecutive event numbers (event number is incremented up to 150 and then the oldest number is overwritten)
Device x	Number of device
Message # x	Display of a message or message number (the messages are described in detail under Messages for safety device diagnostics)

Web server

A web server is implemented in the fieldbus module SDD ES EIP. This can be used to poll data from the SDD.

- ▶ The web server is started once the SDD ES EIP is connected to the supply voltage.
- ▶ The web server is intended for use with Internet Explorer or Firefox.
- ▶ Make sure that Javascript and Cookies are enabled in your browser's security settings.

Start of the web server

1. Connect the SDD ES EIP to the PC.
2. Call up the HTML page:
 - **http://192.168.0.xxx**
 - For xxx, enter the value that you have set as the last byte of the IP address.
3. Enter the user name and password correctly and log on to the web application.
4. Select the option you require in the overview and then follow the instructions.

Device History

The last 23 messages since the SDD ES EIP was switched on are displayed.

The messages are described in the System Description "Safety Device Diagnostics".

Updated by reload: this page is updated by reloading the page in the browser.

Device Info

The information available about the connected safety devices on the SDD ES EIP is displayed.

Updated automatically: this page is updated automatically every second.

Column name	Value range	Meaning
Device Info		Status of the SDD ES EIP
Devices	1-16	Number of connected safety devices
Safety Gate	Green = closed Grey = open	Status of the connected safety devices without guard locking
Lock	Green = activated Grey = deactivated	Status of the connected guard locking devices
OSSD 1&2	Green = closed Grey = open	Status of the connected OSSD
I/O		Value that is read in at the GPIOs
Time in sec		Time in seconds since power-up (jumps back to 0 after 65535 seconds)

Device Event

Display of events that have occurred. The last 23 entries are displayed.

The data is stored in a permanent memory and so is still available after the supply voltage is switched back on.

The event number is displayed for each event, along with max. 3 additional lines with further details. The events are described in detail in Messages for safety device diagnostics.

Updated by reload: this page is updated by reloading the page in the browser.



Device xx

Option	Value range	Meaning	
Coded Switch	e.g. Coded Switch	Information about device type	
Device Info	◆ / ◇	Status of safety device (updated automatically)	
		◆	Ready
		◇	Not available
Safety Gate	◆ / ◇	Status of safety gate	
		◆	Actuator within the response range
		◇	Actuator not within the response range
Lock	◆ / ◇	Status of guard locking	
		◆	activated
		◇	deactivated
OSSD 1&2	◆ / ◇	Status OSSD1 & 2 (updated automatically)	
		◆	closed
		◇	open
SN#		Serial number of safety device	
Ident#		Material number of safety device	
Actuator#		Short name of the actuator (updated automatically)	
Device Type	C, F, U	Pilz coding type C = coded F = fully coded U = uniquely fully coded	
Teach In Free	1-8	Number of teach-in processes remaining	
Temperature in °C		Temperature in °C	

Updated by reload: this page is updated by reloading the page in the browser.

Settings

The following options are available under **Settings**:

- ▶ [Manage equipment identifier for the connected safety devices](#)  27]
- ▶ [Set and store GPIO values](#)  27]
- ▶ Manage password for the range **Settings** (see [Set new Password](#)  28])

This is the preset login data when the device is delivered:

- User = User
Password = 1111
- Admin = Admin
Password = 0000

Once logged in, you can log out again with logout. Logout occurs automatically when the SDD ES EIP is restarted or the browser is closed.

- ▶ Delete the list of events (see [Delete Events](#)  28])
- ▶ The **Settings** area can be used by 2 users simultaneously.
- ▶ **Download data**

The values in the areas `Settings`, `Device Info`, `Device History` and `Device Event` can be exported by clicking `Download` and saving the displayed content.

Setting

A name can be assigned to the safety device in Value.

	Value range in the <i>Value</i> field	Status
Equipment Identifier xx	Max. 16 characters (letters, numbers and special characters)	Status of change Saved = Change was stored and adopted

GPIO

The current values at the GPIO are displayed and can be changed.

If the value is changed, select the new value in the value list.

- ▶ Save changes

Changes can be saved using **Save Settings**. Once saved, the change is visible immediately in the display of the SDD ES EIP.

- ▶ Export settings

The current setting can be saved as an HTML file.

Click on **Export Settings**. A **DOWNLOAD LINK** is displayed. Right-click on **DOWNLOAD LINK** and save the file.

- ▶ Import settings

Saved settings can be imported.

Click on **Import Settings** and select an HTML file with settings. The imported settings must be saved using **Save Settings** in order for them to take effect.

Delete Events

▶ **Delete Events**

The list of events can be deleted.

- Click on **Delete**.
- **All Events will be deleted please confirm** is displayed
Click **OK** to delete all previous events.
Click **Abort** if no events are to be deleted.

Set new Password

A new password should be set after the SDD ES EIP is switched on for the first time.

You must be logged in as an administrator to change the password.

1. If required, log in as an administrator.
2. Enter the old password in the **Old Password** field and enter the new password in the **New Password** field.
Enter the new password again under **Confirm new Password** and click on **Set Password**.

Firmware update

The firmware and the web server of SDD ES EIP can be updated.

1. Set the IP address of the configuration PC to the address range of the SDD ES EIP (e.g. 192.168.0.1).
To access SDD ES EIP, the IP address of the PC has to be in the same subnet as the IP address of SDD ES EIP
Change the IP address in the network settings of your configuration PC or change the IP address of the SDD ES EIP (see Set IP address).
2. Establish an FTP connection to the Gateway, using the user name "Admin" and password "0000".
3. Copy the files "SDD_xxx.kfu" and "password.xml" and the directory "web" with FTP to the SDD ES EIP and save the files in the topmost directory.
4. Perform a [restart](#)  21 of SDD ES EIP. The changed configuration is therefore adopted.

Dimensions in mm

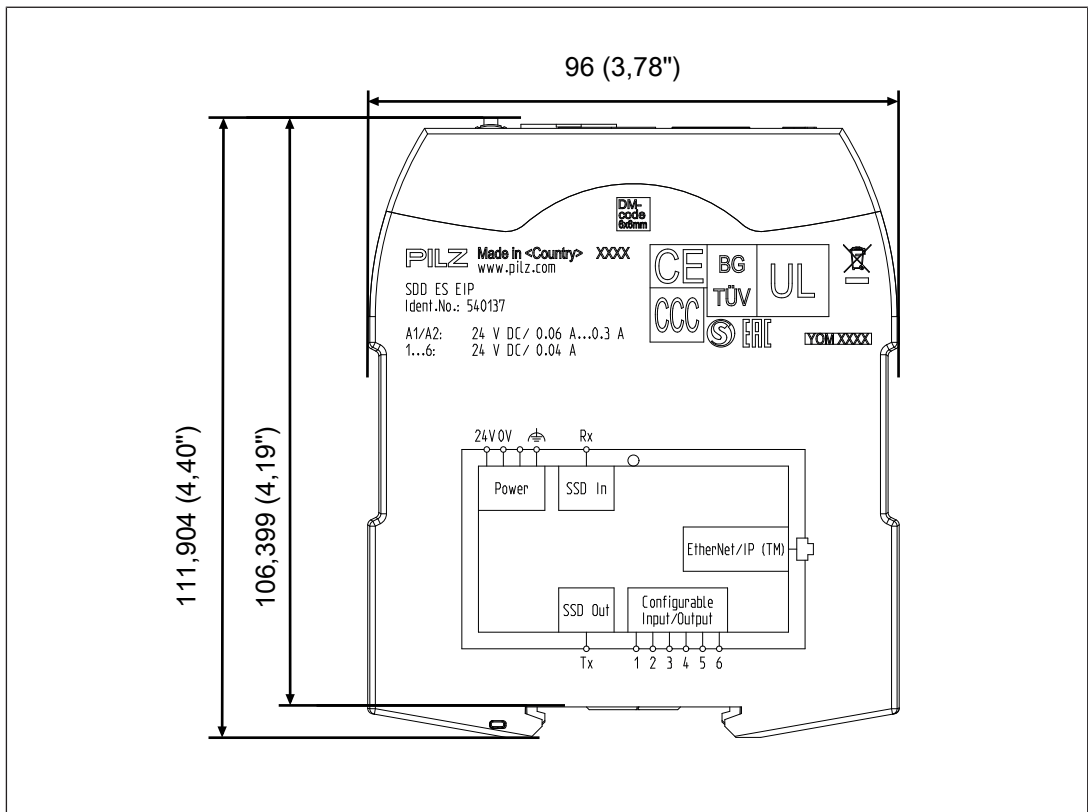
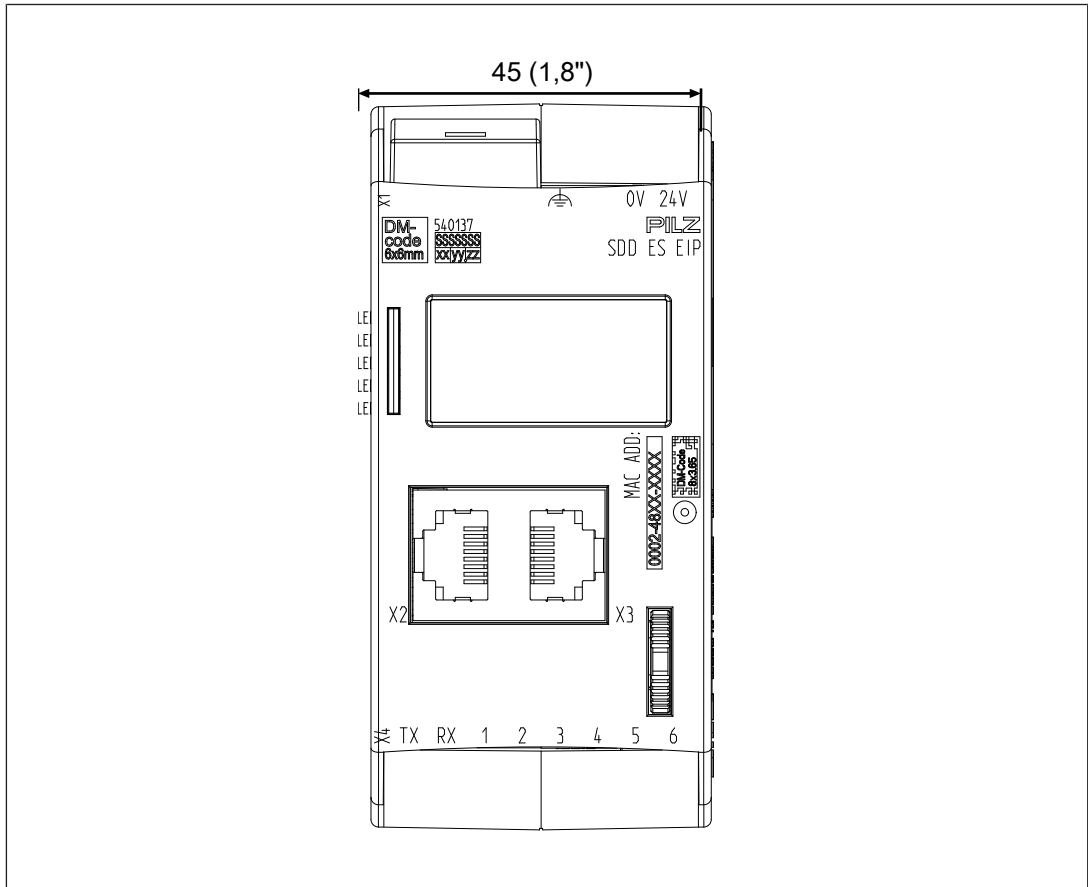

Technical details

General	
Certifications	CE, cULus Listed
Electrical data	
Supply voltage	
for	Module supply
Voltage	24 V
Kind	DC
Output of external power supply (DC)	2 W
Status indicator	Display, LED
Inputs	
Number	6
Semiconductor outputs	
Number	6
Short circuit-proof	yes
Semiconductor outputs (standard)	
Switching capability	
Voltage	24 V
Current	0,04 A
Power	1 W
Fieldbus interface	
Fieldbus interface	EtherNet/IP (TM)
Log	EtherNet/IP (TM) (adapter)
Maximum data length of fieldbus interface	
Input/output combined	512 Byte
Transmission rates	10 MBit/s, 100 MBit/s
Connection	RJ45
Galvanic isolation	yes
Times	
Supply interruption before de-energisation	20 ms
Environmental data	
Ambient temperature	
In accordance with the standard	EN 60068-2-14
Temperature range	0 - 55 °C
Storage temperature	
In accordance with the standard	EN 60068-2-1/-2
Temperature range	-25 - 70 °C
Climatic suitability	
In accordance with the standard	EN 60068-2-30, EN 60068-2-78
Humidity	90 % r. h. at 55 °C
Condensation during operation	Not permitted
Max. operating height above sea level	2000 m
EMC	EN 61000-4-3, EN 61000-4-5, EN 61000-4-6, EN 61000-6-4

Environmental data	
Vibration	
In accordance with the standard	EN 60068-2-6
Frequency	5 - 150 Hz
Acceleration	1g
Shock stress	
In accordance with the standard	EN 60068-2-27
Acceleration	15g
Duration	11 ms
Protection type	
In accordance with the standard	EN 60529
Housing	IP20
Terminals	IP20
Mounting area (e.g. control cabinet)	IP54
Potential isolation	
Potential isolation between	Ethernet and system voltage
Type of potential isolation	Functional insulation
Rated surge voltage	2500 V
Mechanical data	
Mounting position	Any
DIN rail	
Top hat rail	35 x 7,5 EN 50022
Material	
Bottom	PC
Front	PC
Top	PC
Connection type	Spring-loaded terminal, plug-in, screw terminal, plug-in
Conductor cross section with screw terminals	
1 core flexible	0,25 - 2,5 mm², 24 - 12 AWG
Dimensions	
Height	115 mm
Width	45 mm
Depth	95 mm
Weight	160 g

Where standards are undated, the 2016-02 latest editions shall apply.

Supplementary data

Network data

Interface	Protocol	Direction	Transport log	Port No.	Can be de-activated	Description
User interface	HTTP	In/out	TCP	80	No	Browser, web interface
File Transfer	FTP	in/out	TCP	21	No	FTP connection for firm-ware updates
DHCP	BOOTP	in/out	UDP	67 68	Yes	Automatic receipt of a network address
EtherNet/IP	CIP, Ether-Net/IP	in/out	TCP UDP	44818 (TCP/UDP) 2222 (UDP)	No	Data exchange via EtherNet/IP connection

Order reference

Product

Product type	Features	Order no.
SDD ES EIP	Fieldbus module EtherNet/IP (TM) for Safety Device Diagnostics	540 137

Accessories

Product type	Features	Order no.
SDD ES SET SCREW TERMINALS	Screw terminals, plug-in	540 120
SDD ES SET SPRING LOADED TERMINALS	Spring-loaded terminals, plug-in	540 121

Product type	Connection X1	Connection X2	Connection X3	Order no.
PSEN Y junction M12 SENSOR	M12, 8-pin, pin	M12, 8-pin, socket	M12, 8-pin, socket	540 315
PSEN Y junction M12 cable channel	M12, 8-pin, pin	M12, 8-pin, socket	M12, 8-pin, socket	540 316
PSEN T junction M12	M12, 8-pin, socket	M12, 8-pin, pin	M8, 4-pin, pin	540 331

Product type	Connection X1	Connection X2	Connection X3	Order no.
PSEN Y junction M8-M12/ M12 PIGTAIL	M12, 8-pin, socket	M12, 8-pin, pin	M8, 8-pin, socket	540 337
PSEN Y junction M12-M12/ M12 PIGTAIL	M12, 8-pin, socket	M12, 8-pin, pin	M12, 8- pin, socket	540 338

Product type	Features	Connector X1	Connector X2	Connector X3	Order no.
PSEN ml Y junction M12		M12, 8-pin male connector	M12, 8-pin fe- male connector	M12, 12-pin fe- male connector	570486
PSEN ml / PSENcs Y junction M12		M12, 8-pin fe- male connector	M12, 8-pin male connector	M12, 8-pin fe- male connector	570489

EC declaration of conformity

This/(These) product(s) fulfil the requirements of the low voltage directive 2006/95/EG. The complete EC Declaration of Conformity is available on the Internet at www.pilz.com/downloads.

Representative: Norbert Fröhlich, Pilz GmbH & Co. KG, Felix-Wankel-Str. 2, 73760 Ostfildern, Germany

