



▶ PSSu K F FCU

PILZ

THE SPIRIT OF SAFETY

Operating Manual-1002391-EN-12

- Decentralised system PSSuniversal I/O



This document is the original document.

Where unavoidable, for reasons of readability, the masculine form has been selected when formulating this document. We do assure you that all persons are regarded without discrimination and on an equal basis.

All rights to this documentation are reserved by Pilz GmbH & Co. KG. Copies may be made for the user's internal purposes. Suggestions and comments for improving this documentation will be gratefully received.

Pilz®, PIT®, PMI®, PNOZ®, Primo®, PSEN®, PSS®, PVIS®, SafetyBUS p®, SafetyEYE®, SafetyNET p®, the spirit of safety® are registered and protected trademarks of Pilz GmbH & Co. KG in some countries.



SD means Secure Digital

1	Introduction	5
1.1	Validity of documentation	5
1.1.1	Retaining the documentation	5
1.1.2	Terminology: System environment A and B	5
1.2	Definition of symbols	6
2	Overview	7
2.1	Module structure	7
2.2	Module features	7
2.3	Front view	9
3	Safety	10
3.1	Intended use	10
3.2	Safety regulations	10
3.2.1	Safety assessment	10
3.2.2	Use of qualified personnel	11
3.2.3	Warranty and liability	11
3.2.4	Disposal	11
4	Function description	12
4.1	Block diagram	12
4.2	Module and periphery supply	12
4.3	Reaction times	13
4.4	Inputs	13
4.5	Outputs	14
4.5.1	Single-pole outputs	14
4.5.2	Dual-pole outputs	16
4.5.3	Notes	18
4.5.4	Processing time for outputs	18
4.6	Integrated protection mechanisms	19
4.7	Pulse stretch mode	20
4.7.1	Signal detection at the input	21
4.7.1.1	Safely filtered out signals	21
4.7.1.2	Safely detected signals with input pairs	22
4.7.1.3	Safely detected signals without input pairs	23
4.7.2	Signal states and timing diagrams	24
4.7.3	Configuration	28
4.7.3.1	Access to I/O data types	29
4.7.4	Reaction times	29
4.8	Fast shutdown mode	30
4.8.1	Signal detection at the input	32
4.8.1.1	Safely filtered out signals	32
4.8.1.2	Processing times of detected signals	32
4.8.1.3	Safely detected signals	33
4.8.2	Configuration	34
4.8.2.1	Access to I/O data types	34
4.8.3	Overall reaction time with fast shutdown	34

5	Installation	36
5.1	General installation guidelines	36
5.1.1	Dimensions	37
5.2	Install compact module	38
5.3	Install/uninstall connector	40
5.4	Install labelling bracket	41
6	Wiring	42
6.1	General wiring guidelines	42
6.2	Connectors' mechanical connection	42
6.3	Connect/disconnect the cables	43
6.4	Terminal configuration	44
6.5	Connecting the module	46
6.6	Function test during commissioning	50
7	Operation	51
7.1	Messages	51
7.2	Display elements	52
7.2.1	Display elements for module diagnostics	52
7.2.2	Display elements for input and output status	53
8	Technical details	54
8.1	Safety characteristic data	58
9	Order reference	59
9.1	Product	59
9.2	Accessories	59
10	EC declaration of conformity	60
11	UKCA-Declaration of Conformity	61

1 Introduction

1.1 Validity of documentation

This documentation is valid for the product PSSu K F FCU. It is valid until new documentation is published.

This operating manual explains the function and operation, describes the installation and provides guidelines on how to connect the product.

1.1.1 Retaining the documentation

This documentation is intended for instruction and should be retained for future reference.

1.1.2 Terminology: System environment A and B

The PSSu system can be used in two different system environments. The module's application area is described in the chapter "Intended Use" of the manual.

The distinction is made between

- ▶ PSSu in system environment A
- ▶ PSSu in system environment B

The distinction is based on the application area of the PSSu system.

PSSu in system environment A may be used in the

- ▶ Decentralised system PSSu I/O
- ▶ **Not** in the automation system PSS 4000

PSSu in system environment B may be used in the

- ▶ Automation system PSS 4000, e.g. with
 - Decentralised system PSSu I/O with SafetyNET p
 - Control system PSSu PLC
 - Control system PSSu multi

The module PSSu K F FCU is exclusively for use in system environment B (automation system PSS 4000).

1.2 Definition of symbols

Information that is particularly important is identified as follows:



DANGER!

This warning must be heeded! It warns of a hazardous situation that poses an immediate threat of serious injury and death and indicates preventive measures that can be taken.



WARNING!

This warning must be heeded! It warns of a hazardous situation that could lead to serious injury and death and indicates preventive measures that can be taken.



CAUTION!

This refers to a hazard that can lead to a less serious or minor injury plus material damage, and also provides information on preventive measures that can be taken.



NOTICE

This describes a situation in which the product or devices could be damaged and also provides information on preventive measures that can be taken. It also highlights areas within the text that are of particular importance.



INFORMATION

This gives advice on applications and provides information on special features.

2 Overview

2.1 Module structure

The module combines the function unit (inputs and outputs) and connection levels in one housing.

Wiring is via 10-pin connectors with spring-loaded terminals, which are plugged into the module's connector strips.

Details of the applicable connectors with spring-loaded terminals are available under "Intended use".

2.2 Module features

- ▶ For failsafe applications in system environment B (automation system PSS 4000)
- ▶ Operating modes:
 - Pulse stretching supported from FS firmware version 1.13.0 of the head modules and from firmware version 06 of the module.
 - Fast shutdown supported from FS firmware version 1.7.0 of the head modules
- ▶ Maximum number of modules: 12
- ▶ Configurable input filter
- ▶ 12 digital inputs
- ▶ Filter time can be configured
- ▶ 2 independent test pulse outputs that use different test pulses
- ▶ 2 Digital outputs
 - Semiconductor technology
 - Single-pole
 - Positive-switching
 - Current load capacity per output: 2 A
 - Short circuit-proof
 - Overload-proof
 - Free from feedback
- ▶ 2 Dual-pole digital outputs
 - Semiconductor technology
 - Switches to 24 V (Ox+) and 0 V (Ox-)
 - Current load capacity: 3 A
 - Short circuit-proof
 - Overload-proof
 - High discharge voltage
 - Free from feedback
- ▶ LEDs for:
 - Switch status of each input/output

- Module error
- Module status
- ▶ 4 x 10-pin connector strip

Accessories:

- ▶ Connector with spring-loaded terminals (necessary for operation)
- ▶ Labelling bracket
- ▶ Labelling strips (sheets)

2.3 Front view

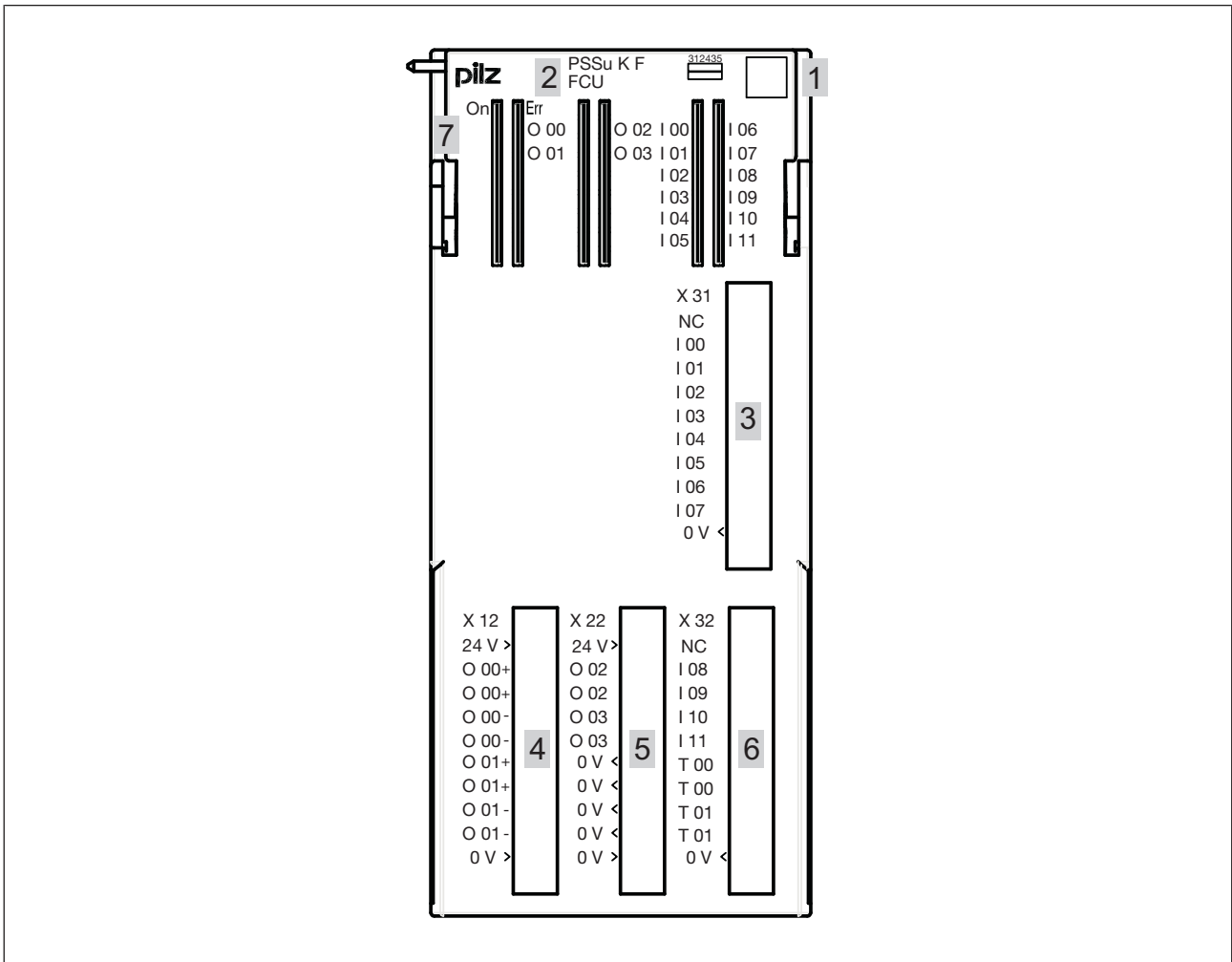

Legend:

- ▶ 1: Labelling strip with:
 - 2D code
 - Order number
 - Serial number
 - Hardware version number
- ▶ 2: Name of compact module
- ▶ 3: Connector strip X31 for connectors with spring-loaded terminals and labelling strip
- ▶ 4: Connector strip X12 for connectors with spring-loaded terminals and labelling strip
- ▶ 5: Connector strip X22 for connectors with spring-loaded terminals and labelling strip
- ▶ 6: Connector strip X32 for connectors with spring-loaded terminals and labelling strip
- ▶ 7: LEDs for status display and module diagnostics

3 Safety

3.1 Intended use

The module may be used for failsafe applications in system environment B (automation system PSS 4000).

It provides type 1 failsafe inputs in accordance with IEC 61131-2.

It provides type 1 single and dual-pole failsafe outputs in accordance with IEC 61131-2.

The outputs may be used to switch:

- ▶ Resistive loads
- ▶ Inductive loads
- ▶ Capacitive loads (refer to the characteristics "Capacitance C on single-pole outputs dependent on load current I" and "Capacitance C on dual-pole outputs dependent on load current I")

Intended use includes making the electrical installation EMC-compliant. Please refer to the guidelines stated in the "PSSuniversal Installation Manual". The module is designed for use in an industrial environment. It is not suitable for use in a domestic environment, as this can lead to interference.

The following is deemed improper use in particular:

- ▶ Any component, technical or electrical modification to the module
- ▶ Use of the module outside the areas described in this manual
- ▶ Any use of the module that is not in accordance with the technical details.



INFORMATION

The module is supported by PAS4000 from version 1.7.0. Pulse stretching is supported by PAS4000 from version 1.13.0. We recommend that you always use the latest version (download from www.pilz.de).

3.2 Safety regulations

3.2.1 Safety assessment

Before using a device, a safety assessment in accordance with the Machinery Directive is required.

The product as an individual component fulfils the functional safety requirements in accordance with EN ISO 13849 and EN IEC 62061. However, this does not guarantee the functional safety of the overall plant/machine. To achieve the relevant safety level of the overall plant/machine's required safety functions, each safety function needs to be considered separately.

3.2.2 Use of qualified personnel

The products may only be assembled, installed, programmed, commissioned, operated, de-commissioned and maintained by persons who are competent to do so.

A competent person is a qualified and knowledgeable person who, because of their training, experience and current professional activity, has the specialist knowledge required. In order to inspect, assess and handle products, devices, systems, plant and machinery, this person must be familiar with the state of the art and the applicable national, European and international laws, directives and standards.

It is the company's responsibility only to employ personnel who

- ▶ Are familiar with the basic regulations concerning health and safety / accident prevention,
- ▶ Have read and understood the information provided in the section entitled Safety
- ▶ Have a good knowledge of the generic and specialist standards applicable to the specific application.

3.2.3 Warranty and liability

All claims to warranty and liability will be rendered invalid if

- ▶ The product was used contrary to the purpose for which it is intended,
- ▶ Damage can be attributed to not having followed the guidelines in the manual,
- ▶ Operating personnel are not suitably qualified,
- ▶ Any type of modification has been made (e.g. exchanging components on the PCB boards, soldering work etc.).

3.2.4 Disposal

- ▶ In safety-related applications, please comply with the mission time T_M stated in the safety-related characteristic data.
- ▶ When decommissioning, please comply with local regulations regarding the disposal of electronic devices (e.g. Electrical and Electronic Equipment Act).

4 Function description

4.1 Block diagram

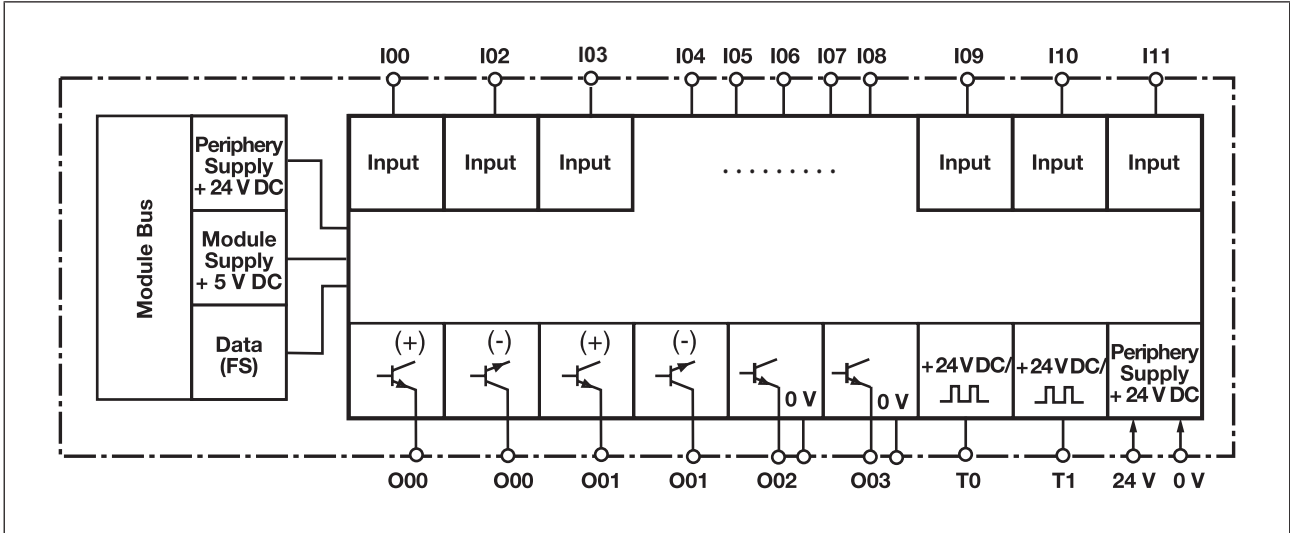

4.2 Module and periphery supply

Module supply

- ▶ The module supply provides the module with voltage.

Periphery Supply

- ▶ The periphery supply for the test pulse outputs is switched from the module bus to the module's connector strips.
- ▶ The periphery supply for the outputs must be fed in externally. The single and dual-pole outputs must have a common supply voltage.

4.3 Reaction times

The times t_{ProcIM} and t_{ProcOM} on the PSSu K F FCU must be considered for the reaction times.

▶ t_{ProcIM}

Calculation of the values for t_{ProcIM} depends on the operating mode.

– Fast shutdown mode

If you use the inputs and outputs of the PSSu K F FCU for local fast shutdown, you will find the information for calculating the reaction times under [Overall reaction time for fast shutdown](#) [ 34].

– Pulse stretch mode

If you process the inputs and outputs of a PSSu K F FCU in the user program of the PSS 4000 project, you will find the information for calculating the reaction times under "Pulse stretch mode", under [Reaction times](#) [ 29].

▶ t_{ProcOM}

The values for t_{ProcOM} can be found in the technical details.

4.4 Inputs

Digital inputs:

- ▶ 12 digital inputs
- ▶ Test pulses can be used to check the inputs for shorts across contacts and correct functionality.
- ▶ The input filter time is configurable.

Digital inputs I00 ... I07:

- ▶ Digital inputs for pulse stretching or fast shutdown

Digital inputs I08 ... I11:

- ▶ The function of these inputs is independent of the operating mode.
- ▶ The inputs can be used to connect safety switches, for example.

Test pulse outputs

- ▶ 2 test pulse outputs that use different test pulses (test pulse T00, test pulse T01)
- ▶ Short circuit-proof
- ▶ Overload-proof
- ▶ Free from feedback
- ▶ Current-limiting

Detection of shorts across contacts

- ▶ The test pulses are used to detect shorts between inputs. Shorts between inputs are detected when the test pulses are different (test pulse T00, test pulse T01).
- ▶ Only the module's test pulses may be used to detect shorts.
- ▶ The module's test pulses may not be used to detect shorts between inputs on other modules.
- ▶ Shorts between inputs of the same module with the same test pulses will not be detected.
- ▶ Test pulses can be switched on or off.
- ▶ Test pulses are switched on in the default setting.

- ▶ When test pulses are switched off, the periphery supply is constantly available at the test pulse outputs.

4.5 Outputs

4.5.1 Single-pole outputs

- ▶ 2 single-pole digital outputs

Output test

- ▶ Outputs that are switched on are checked via regular off tests.
 - Test pulses for outputs that are switched on: see [Technical details \[54\]](#)
 - Outputs that are switched on are switched off for the duration of the test pulse.
 - The load must not switch off because of the test.
- ▶ Outputs that are switched off are checked via regular on tests.
 - Test pulses for outputs that are switched off: see [Technical details \[54\]](#)
 - Outputs that are switched off are switched on for the duration of the test pulse.
 - The load must not switch on because of the test.

Testing for shorts

- ▶ A test is regularly carried out to check for shorts between the outputs.

Excluding individual outputs from the output test:

- ▶ If a plant is particularly sensitive to the test pulses, the output test may be switched off for individual outputs.
- ▶ The test must be replaced by other measures, depending on the safety requirement.
- ▶ When test pulses are switched off:
 - The correct switch status is always checked.
 - The output's ability to switch will not be detected until the next time the output is switched on/off.

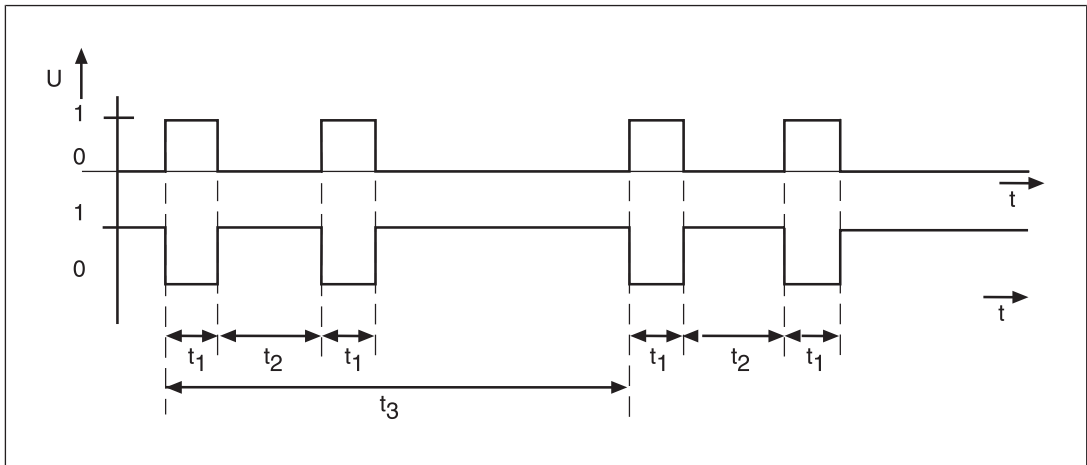

Fig.: On and off test for single-pole outputs

Legend

t_1 Pulse duration of on/off test (200 μs)

t_2 Max. waiting time between the on/off test (approx. 4 ms)

t_3 Repetition time of on and off test in normal circumstances (approx. 2 s)

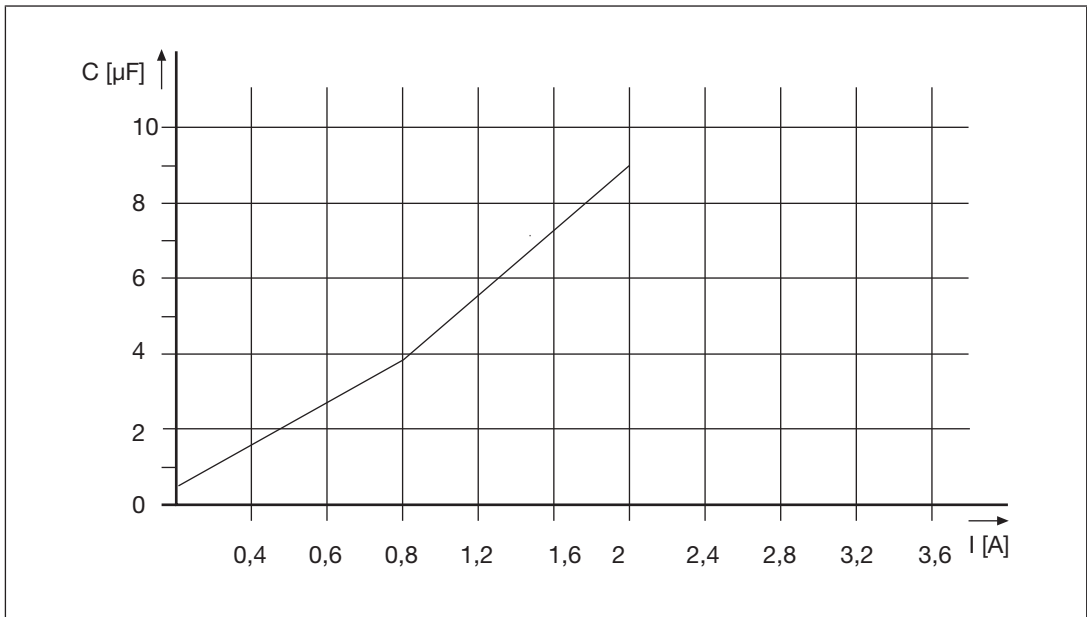

Fig.: Characteristic for single-pole outputs: Output capacitance C dependent on load current I

4.5.2 Dual-pole outputs

- ▶ 2 dual-pole digital outputs (cannot be used as a single-pole output)

Output test

- ▶ Outputs that are switched on are checked via regular off tests.
 - Test pulses for outputs that are switched on: see [Technical details \[54\]](#)
 - Outputs that are switched on are switched off for the duration of the test pulse.
 - The load must not switch off because of the test.
- ▶ Outputs that are switched off are checked via regular on tests.
 - Test pulses for outputs that are switched off: see [Technical details \[54\]](#)
 - Outputs that are switched off are switched on for the duration of the test pulse.
 - The load must not switch on because of the test.

Testing for shorts

- ▶ A test is regularly carried out to check for shorts between the outputs.

Open circuit detection (only on dual-pole outputs):

- ▶ The module will detect an open circuit between outputs O0x+ and O0x-.
- ▶ The result of open circuit detection is entered as an error in the diagnostic list and all outputs are deactivated.
- ▶ The outputs will not be switched on until the head module is restarted.
- ▶ Connected loads with an impedance of greater than 0,17 kOhm are detected as an open circuit.
- ▶ Even between unused outputs O0x+ and O0x-, an open circuit will be detected and signalled as an output error.
 - Place a jumper between unused outputs.
 - Make sure that bridged outputs are not switched on in the user program, otherwise an output error will be signalled.

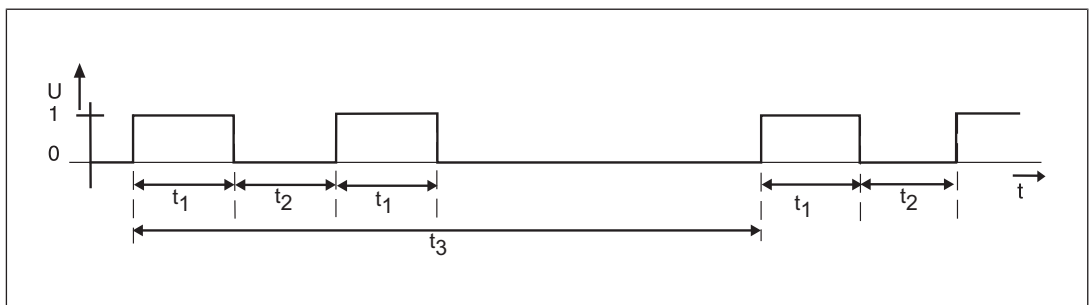

Fig.: On test for dual-pole outputs

Legend

- t_1 Max. pulse duration of on test (4 ms)
- t_2 Max. waiting time between the on tests (approx. 4 ms)
- t_3 Repetition time of on test in normal circumstances (approx. 2 s)

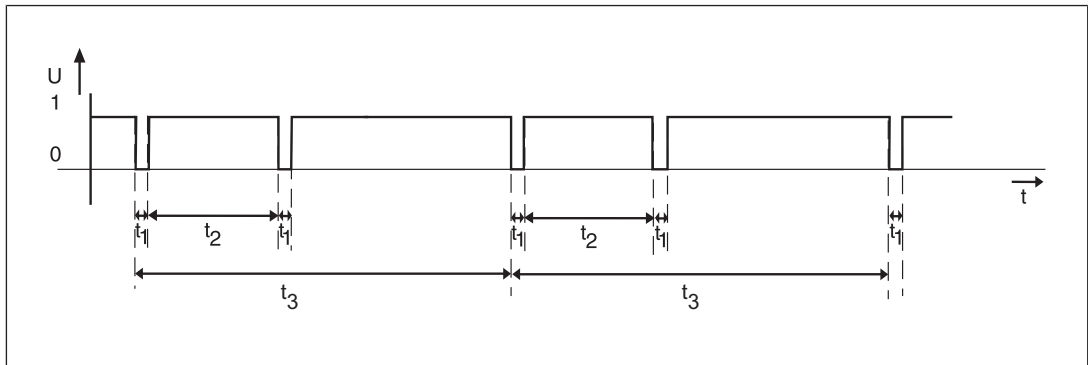

Fig.: Off test for dual-pole outputs

Legend

- t_1 Pulse length of off test (0.2 ms)
- t_2 Max. waiting time between the off tests (approx. 4 ms)
- t_3 Repetition time of off test in normal circumstances (approx. 2 s)

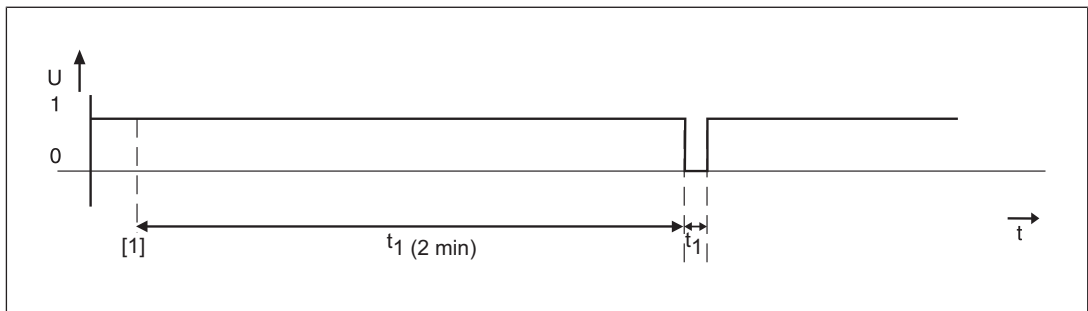

Fig.: Discharge voltage test

Legend

- [1] Start of off test for dual-pole outputs
- t_1 Waiting time between discharge voltage tests (2 min)
- t_2 Pulse duration of discharge voltage test (approx. 0.3 ms)



NOTICE

Risk from high discharge voltage!

The discharge voltage when switching off an inductive load is up to -185 V. The connected load can be damaged by the discharge voltage.

- Limit the discharge voltage if the connected load can be damaged by this discharge voltage.

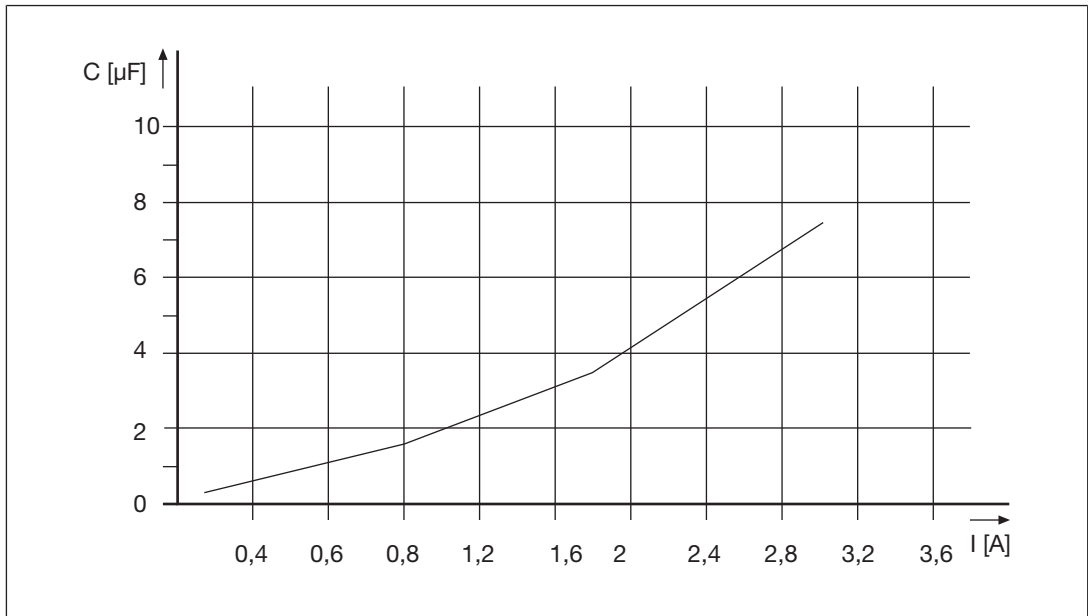

Fig.: Characteristic for dual-pole outputs: Output capacitance C dependent on load current

4.5.3

Notes



WARNING!

When wiring an output with capacitance it is essential to note the pulse duration, repetition period and scan time of the power-up test, otherwise the load may switch on unintentionally.

- ▶ For applications in accordance with Category 4, PL e and SIL 3, detection of shorts between contacts must be guaranteed either via the on/off test or through other measures (e.g. asynchronous switching). A short between contacts must be simulated during commissioning.

4.5.4

Processing time for outputs

You can find the processing time of the outputs in the technical details.

4.6 Integrated protection mechanisms

When the PSSu E F PS1(-T) or PSSu E F PS2(-T)(-R) is used to supply the system, the module supply is buffered for 20 ms if the supply voltage is interrupted.

The module provides the following diagnostic data:

- ▶ Start-up error
- ▶ Configuration error
- ▶ FS communication error
- ▶ Bus termination error
- ▶ Temperature error: too warm
- ▶ Test pulse error
- ▶ Input error
- ▶ Output error

The module has the following protection mechanisms:

- ▶ Test pulse signals are always buffered for 20 ms
- ▶ Common second shutdown route, tested regularly
- ▶ Cyclical output tests
- ▶ Tests for shorts between the outputs

4.7 Pulse stretch mode

Pulse stretch mode is supported from FS firmware version 1.13.0 of the head modules.

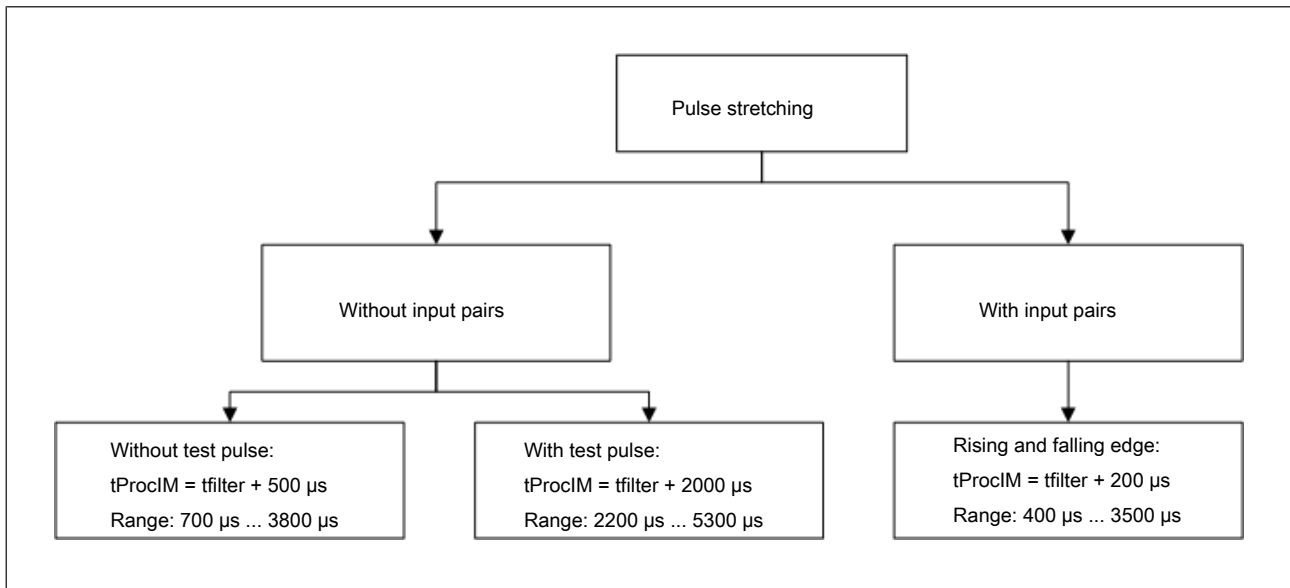

Fig.: Processing times

Legend

t_{ProclM} Time for which a signal must be present at the input in order to be detected safely.

t_{filter} Configurable input filter time

The module stretches detected signals that are present only briefly at input terminals I00 ... I07 so that they are present in the module's process image for the configured pulse stretch time $t_{stretch}$.

Requirement for the configured pulse stretch time $t_{stretch}$:

The configured pulse stretch must be at least as long as the sum of the reaction times of the data subpaths from the module to the task to be processed (see System Description PSS 4000).

Requirement of the signals on the terminals when stretching positive pulses:

- ▶ The 1-signal ($t_{1-Signal}$) must be present at the input for longer than the maximum processing time t_{ProclM} .
- ▶ The 0-signal must be present at the input for longer than the sum of the configured pulse stretch time $t_{stretch}$ and the maximum processing time t_{ProclM} .
- ▶ The 1-signal and the subsequent 0-signal together must be present at the input for longer than twice the sum of the configured pulse stretch time $t_{stretch}$ and the maximum processing time t_{ProclM}

$$- t_{1-Signal} + t_{0-Signal} \geq 2 \times (t_{stretch} + t_{ProclM})$$

Requirement of the signals on the terminals when stretching negative pulses:

- ▶ The 0-signal ($t_{0-Signal}$) must be present at the input for longer than the maximum processing time t_{ProclM} .
- ▶ The 1-signal must be present at the input for longer than the sum of the configured pulse stretch time $t_{stretch}$ and the maximum processing time t_{ProclM} .

- ▶ The 0-signal and the subsequent 1-signal together must be present at the input for longer than twice the sum of the configured pulse stretch time $t_{stretch}$ and the maximum processing time t_{ProclM} .

$$- t_{0-Signal} + t_{1-Signal} \geq 2 \times (t_{stretch} + t_{ProclM})$$

The maximum processing time (t_{ProclM}) depends on the configured filter time and the wiring, see [Safely detected signals with input pairs](#) [22] and [Safely detected signals without input pairs](#) [23].

4.7.1 Signal detection at the input

4.7.1.1 Safely filtered out signals

All signals that are shorter than the signal suppression time t_{pulse_sup} are safely filtered out. The signal suppression time depends on the configured filter time.

Configured input filter time (t_{Filter}) in μs	Signal suppression time (t_{pulse_sup}) in μs
200	13
300	40
400	140
500	240
...	$t_{Filter} - 260$
...	...
...	...
3100	2840
3200	2940
3300	3040

4.7.1.2 Safely detected signals with input pairs

A signal must be present at the input for longer than the maximum processing time t_{ProcIM} in order to be detected safely. Due to the use of input pairs, short signals at an input are also detected. Any two inputs I00 ... I07 can be used as an input pair.

Separate test pulses (T0/T1) must be used for the two inputs forming an input pair, e.g. input I00 must be configured with test pulse T0 and input I01 with test pulse T1. The **24 V** option can also be configured for both inputs.

Configured input filter time (t_{Filter}) in μs	Maximum processing time t_{ProcIM} in μs
200	400
300	500
400	600
500	700
...	$t_{Filter} + 200$
...	...
...	...
3100	3300
3200	3400
3300	3500



NOTICE

Signal times are only guaranteed if input pairs are used.



NOTICE

Possible loss of safety functions by using test pulses!

The duration of the test pulse can be longer than the configured input filter time, whereby input signals are not detected. That way, an output may not safely shut down and, depending on the application, may cause serious injury and death.

Make sure that you always use an input pair for an input signal and that you assign test pulse T0 to one input in the input pair and test pulse T1 to the other input in the input pair.



INFORMATION

If the input filter times are short, the module's electromagnetic immunity towards electromagnetic faults will deteriorate.

4.7.1.3 Safely detected signals without input pairs

A signal must be present at the input for longer than the maximum processing time t_{ProclM} in order to be detected safely. If input pairs are not used, then the maximum processing time is calculated as follows:

▶ Signal times without test pulses:

$$t_{\text{ProclM}} = (t_{\text{Configured input filter time}} + 500 \mu\text{s})$$

▶ Signal times with test pulses

$$t_{\text{ProclM}} = (t_{\text{Configured input filter time}} + 2000 \mu\text{s})$$

4.7.2 Signal states and timing diagrams

Signal states for pulse stretching:

▶ Initialisation:

- After start-up the module is in the "Initialisation" state. A 0-signal is present in the module.
- If a 0-signal is present at the terminal after initialisation has elapsed, then the module switches to the state "Waiting for 1-signal".
- If a 1-signal is present at the terminal after initialisation has elapsed, then the module switches to the state "Waiting for 0-signal".

▶ Waiting for 1-signal

- A 0-signal is present in the module. As soon as a 1-signal is present at the terminals, a timer is started with the configured pulse stretching and the module switches to the state "Stretching 1-signal".

▶ Stretching 1-signal

- A 1-signal is present in the module.
- If a 0-signal is present at the terminals after pulse stretching has elapsed, then the module switches to the state "Stretching 0-signal".
- If a 1-signal is present at the terminals after pulse stretching has elapsed, then the module switches to the state "Waiting for 0-signal".

▶ Waiting for 0-signal

- A 1-signal is present in the module. As soon as a 0-signal is present at the terminals, a timer is started with the configured pulse stretching and the module switches to the state "Stretching 0-signal".

▶ Stretching 0-signal

- A 0-signal is present in the module.
- If a 1-signal is present at the terminals after pulse stretching has elapsed, then the module switches to the state "Stretching 1-signal".
- If a 0-signal is present at the terminals after pulse stretching has elapsed, then the module switches to the state "Waiting for 1-signal".

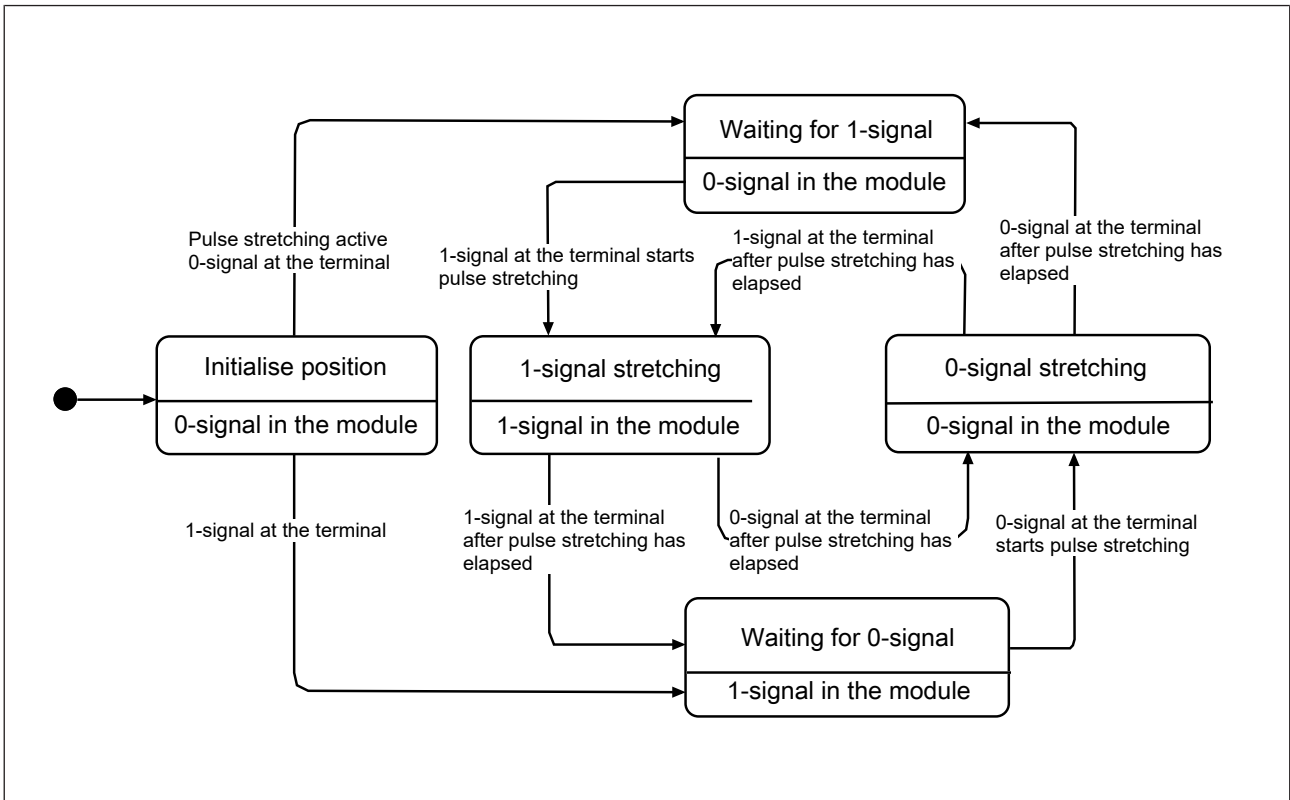

Fig.: State diagram for pulse stretching

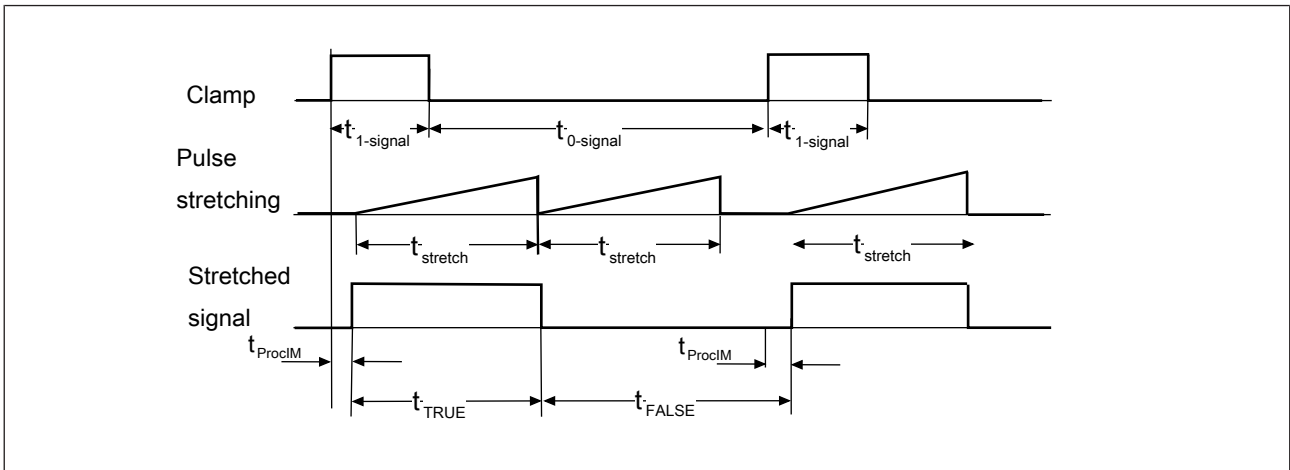

Fig.: Timing diagram: pulse stretching > signal duration of 1-signal

Legend

Clamp Signal at the terminal

Pulse stretching Pulse stretching

Stretched signal Stretched signal

$t_{1\text{-signal}}$ Duration of 1-signal

t_{stretch} Duration of pulse stretching

t_{ProclM} Maximum processing time of input, depending on the configured filter time and wiring

t_{TRUE} Stretched 1-signal in the module

t_{FALSE} Stretched 0-signal in the module

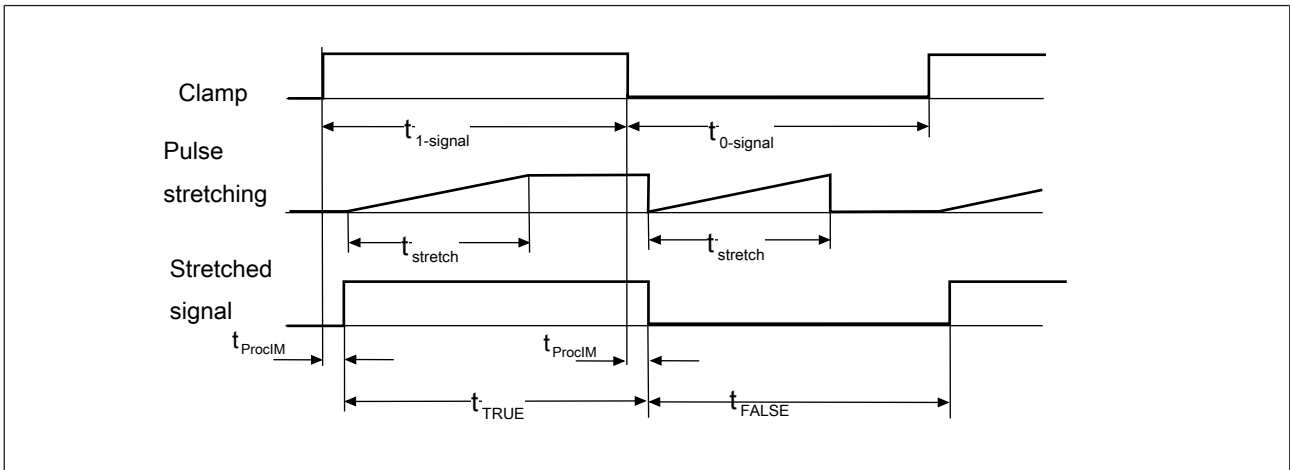

Fig.: Timing diagram: pulse stretching \leq signal duration of 1-signal

Legend

Clamp Signal at the terminal

Pulse stretching Pulse stretching

Stretched signal Stretched signal

$t_{1\text{-signal}}$ Duration of 1-signal

t_{stretch} Duration of pulse stretching

t_{ProclM} Maximum processing time of input, depending on the configured filter time and wiring

t_{TRUE} Stretched 1-signal in the module

t_{FALSE} Stretched 0-signal in the module

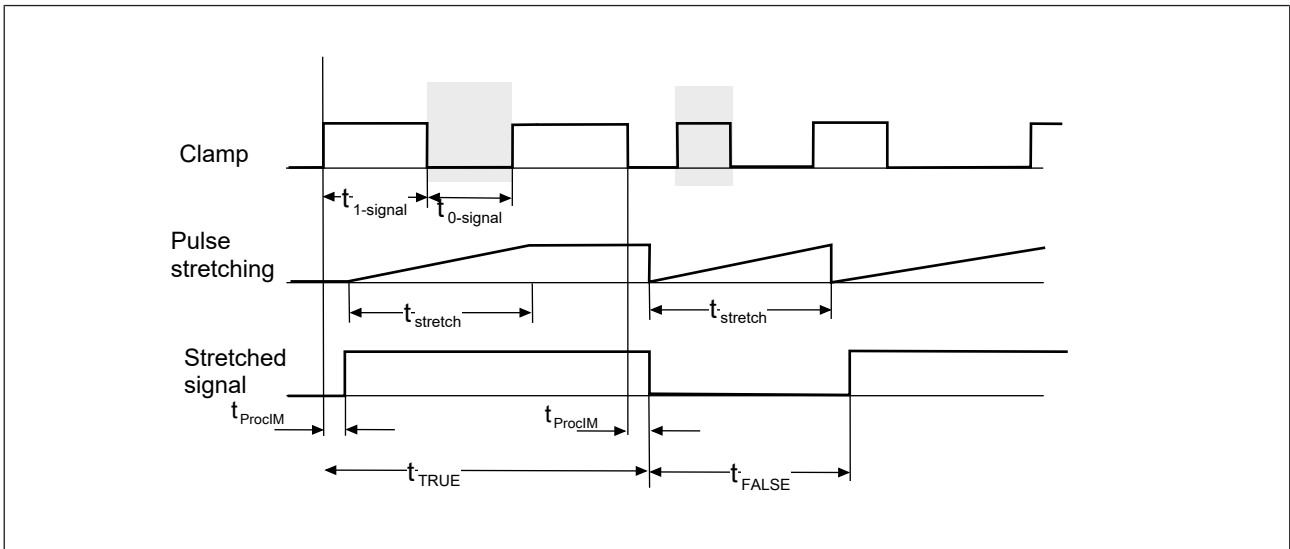

Fig.: Timing diagram: pulse stretching with variable signal duration

Legend

- Clamp Signal at the terminal
- Pulse stretching Pulse stretching
- Stretched signal Stretched signal
- $t_{1\text{-signal}}$ Duration of 1-signal
- t_{stretch} Duration of pulse stretching
- t_{ProclM} Maximum processing time of input, depending on the configured filter time and wiring
- t_{TRUE} Stretched 1-signal in the module
- t_{FALSE} Stretched 0-signal in the module

4.7.3 Configuration

Configuration overview:

Configuration	Default value	Meaning
Input filter times	300 μ s	Filter times can be configured for inputs I00 ... I11.
Pulse stretching	50 ms	Pulse stretching can be configured for inputs I00 ... I07.
On and off test for the outputs	On	Only configurable for single-pole outputs
Test pulse	24 V	24 V: Test pulse switched off T0/T1: Test pulse T0 and T1

Further information is available in PAS4000's online help.

4.7.3.1 Access to I/O data types

Data access is via pre-defined I/O data types:

I/O data name	I/O data type	I/O data element	Meaning
I00 ... I11	FS_I_DI	Data: SAFEBOOL	Input data I00 ... I11
O00 ... O03	FS_O_DO	Data: SAFEBOOL	Output data O00 ... O03

4.7.4 Reaction times

Information on the reaction times of the inputs can be found in the System Description "Automation system PSS 4000".

Please note that the configured input filter time has an effect on the reaction time.

4.8 Fast shutdown mode

Fast shutdown mode is supported from FS firmware version 1.7.0 of the head modules.

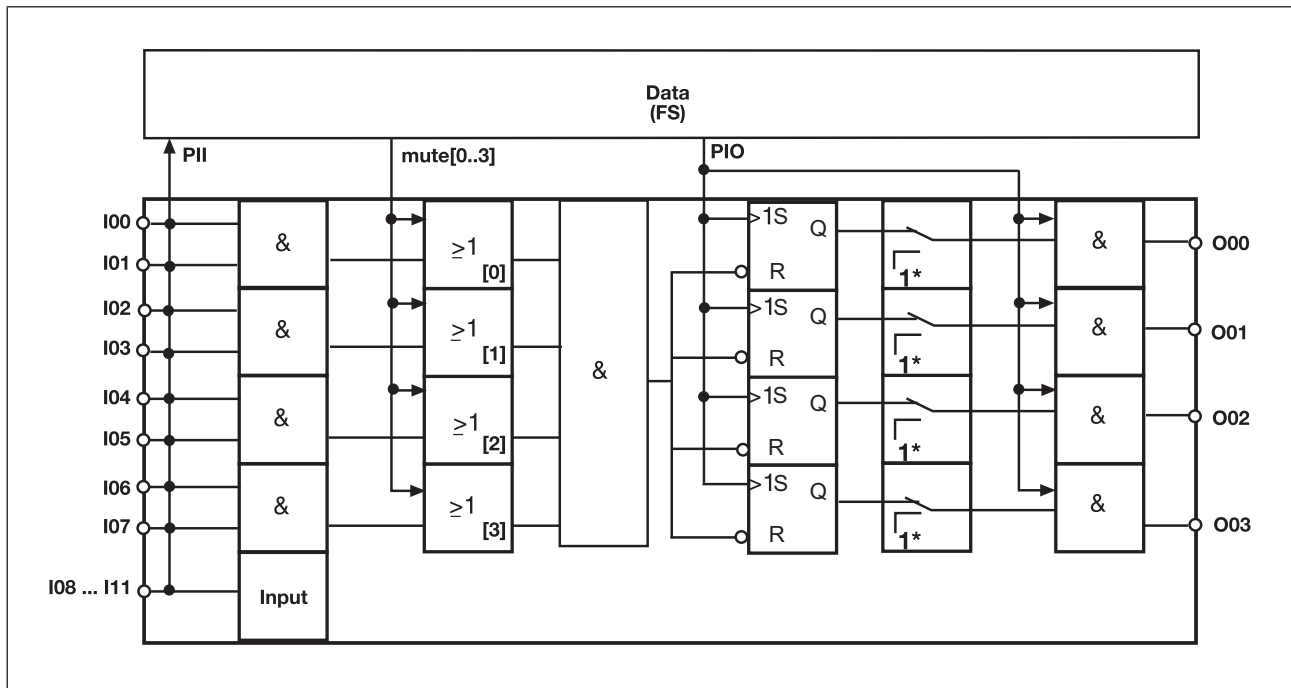

Fig.: Functional overview for fast shutdown

- ▶ Inputs I00 ... I07 form 4 input pairs (I00 and I01, I02 and I03, I04 and I05, I06 and I07). If these input pairs are used it is possible to achieve PL e (Cat. 4) and SIL CL 3.
- ▶ If a signal at these inputs should change, the module's outputs will be shut down immediately. You can determine which input has triggered the fast shutdown by using the data type "FS_I_FCU".
- ▶ It is possible to configure the edge used to trigger the fast shutdown.
- ▶ A joint input filter can be configured for these 8 inputs
- ▶ The inputs can be used to connect OSSDs, for example.
- ▶ Test pulses can be used to check the inputs for shorts across contacts and correct functionality.

Deactivate fast shutdown for inputs

- ▶ The data type "FS_O_FCU" can be used to deactivate the fast shutdown for individual input pairs.
- ▶ The state of these inputs is signalled to the head module via the module bus and no direct shutdown of the outputs occurs.

An overview of the I/O data types can be found under [Access to I/O data types](#) [34].

Deactivate fast shutdown for outputs

- ▶ The configuration software can be used to deactivate the fast shutdown for individual outputs. When the fast shutdown is deactivated, the head module sets the status of the outputs via the module bus.

Further information is available in PAS4000's online help.

Reset fast shutdown

- ▶ To reset a fast shutdown, all outputs for which fast shutdown is actively configured must be set to "FALSE" in the user program.
- ▶ Please note that the output in the controller's user program must remain at "FALSE" until the module has safely detected the value "FALSE". The time this will take depends on the application.
- ▶ A fast shutdown must not be requested at the time of the reset.
- ▶ Depending on the connected sensor, simultaneity monitoring (discrepancy analysis) must be carried out for dual-channel signals before they are acknowledged in the user program, so that the failure of a sensor channel is detected.

4.8.1 Signal detection at the input

4.8.1.1 Safely filtered out signals

All signals that are shorter than the signal suppression time $t_{\text{pulse_sup}}$ are safely filtered out. The signal suppression time depends on the configured filter time and the configured pulse edge for fast shutdown.

Configured input filter time (t_{Filter})	Signal suppression time $t_{\text{pulse_sup}}$ in μs with rising edge	Signal suppression time $t_{\text{pulse_sup}}$ in μs with falling edge
200	13	13
300	30	100
400	130	200
500	230	300
...	$t_{\text{Filter}} - 270$	$t_{\text{Filter}} - 200$
...
...
3100	2830	2900
3200	2930	3000
3300	3030	3100

4.8.1.2 Processing times of detected signals

The processing time of the inputs t_{ProcIM} depends on the:

- ▶ Signal type (single-channel, dual-channel)
- ▶ Test pulse configuration of the inputs
- ▶ Pulse edge of the signal change
- ▶ Configured filter time

Signal type		Dual-channel		Single-channel	
Inputs		T0 and T1 or both 24 V		T0 or T1	24 V
Edge		rising	falling	*	*
Filter time (t_{Filter})	200	100	200	2700	700
	300	200	300	2800	800
	400	300	400	2900	900
	500	400	500	3000	1000
		$t_{Filter} - 100 \mu s$	t_{Filter}	$t_{Filter} + 2500 \mu s$	$t_{Filter} + 500 \mu s$
	3100	3000	3100	5600	3600
	3200	3100	3200	5700	3700
	3300	3200	3300	5800	3800



INFORMATION

If the input filter times are short, the module's electromagnetic immunity towards electromagnetic faults will deteriorate.

4.8.1.3 Safely detected signals

To trigger a fast shutdown, an input signal must be present for longer than the processing time t_{ProclM} .

Information on the minimum signal duration when using the inputs in the user program of a PSS 4000 project can be found in the System Description of the automation system PSS 4000.

4.8.2 Configuration

Configuration	Default value	Meaning
Input filter times	300 µs	The filter times can be configured separately for the inputs I00 ... I07 and I08 ... I11.
Test pulse	T0/T1	24 V: Test pulse switched off T0/T1: Test pulse T0 or T1
Edge used to trigger the fast shutdown	Falling edge	
On and off test for the outputs	On	Only configurable for single-pole outputs
Fast shutdown for the outputs	On	Exclude individual outputs from fast shutdown

Further information is available in PAS4000's online help.

4.8.2.1 Access to I/O data types

Data access is via pre-defined I/O data types:

I/O data name	I/O data type	I/O data element	Meaning
I00 ... I11	FS_I_DI	Data: SAFEBOOL	Input data I00 ... I11
O00 ... O03	FS_O_DO	Data: SAFEBOOL	Output data O00 ... O03
InputData	FS_I_FCU	SwitchedOff : ARRAY[0..7] OF SAFEBOOL	Stores which input has triggered the fast shutdown.
OutputData	FS_O_FCU	Mute: ARRAY[0..3] OF SAFEBOOL	Deactivates the fast shutdown for input pairs (I00 and I01, I02 and I03, I04 and I05, I06 and I07).

4.8.3 Overall reaction time with fast shutdown

The overall reaction time is the time that elapses between a signal being detected at the input and the outputs shutting down. The time depends on the processing time of the inputs t_{ProcIM} and the maximum processing time at the output when a signal changes from "1" to "0".

The maximum reaction time for a fast shutdown is calculated as follows:

$$t_{Fast\ shutdown} = t_{ProcIM} + t_{ProcOM_1 \rightarrow 0}$$

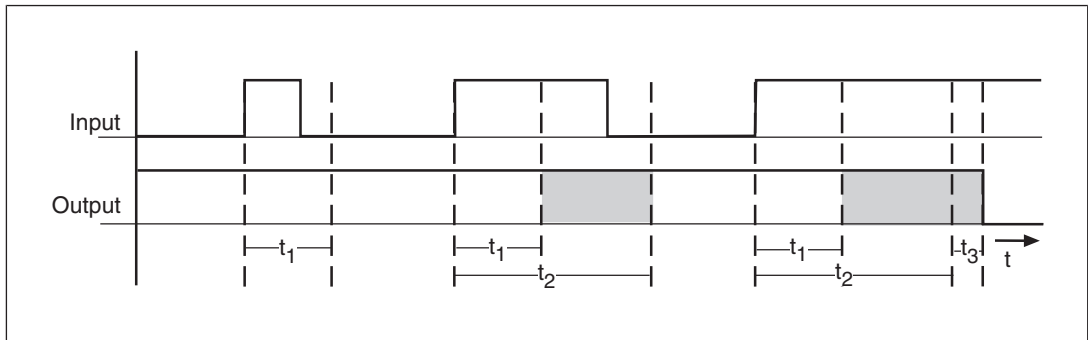

Fig.: Timing diagram for fast shutdown with rising edge with a configured input filter time

Legend

Input Signal at the input

Output Signal at the output

t_1 $t_{\text{pulse_sup}}$, safely filtered out signal time (see [Safely filtered out signals](#) [32])

t_2 t_{ProcIM} Processing time of the inputs (see [Processing time of detected signals](#) [32])

t_3 $t_{\text{ProcOM_1->0}}$, max. processing time of the semiconductor output when a signal changes from "1" to "0" (see Technical details)

Grey shaded Output state not defined area

5 Installation

5.1 General installation guidelines

Please refer also to the PSSuniversal Installation Manual.



NOTICE

Damage due to electrostatic discharge!

Electrostatic discharge can damage components. Ensure against discharge before touching the product, e.g. by touching an earthed, conductive surface or by wearing an earthed armband.

5.1.1 Dimensions

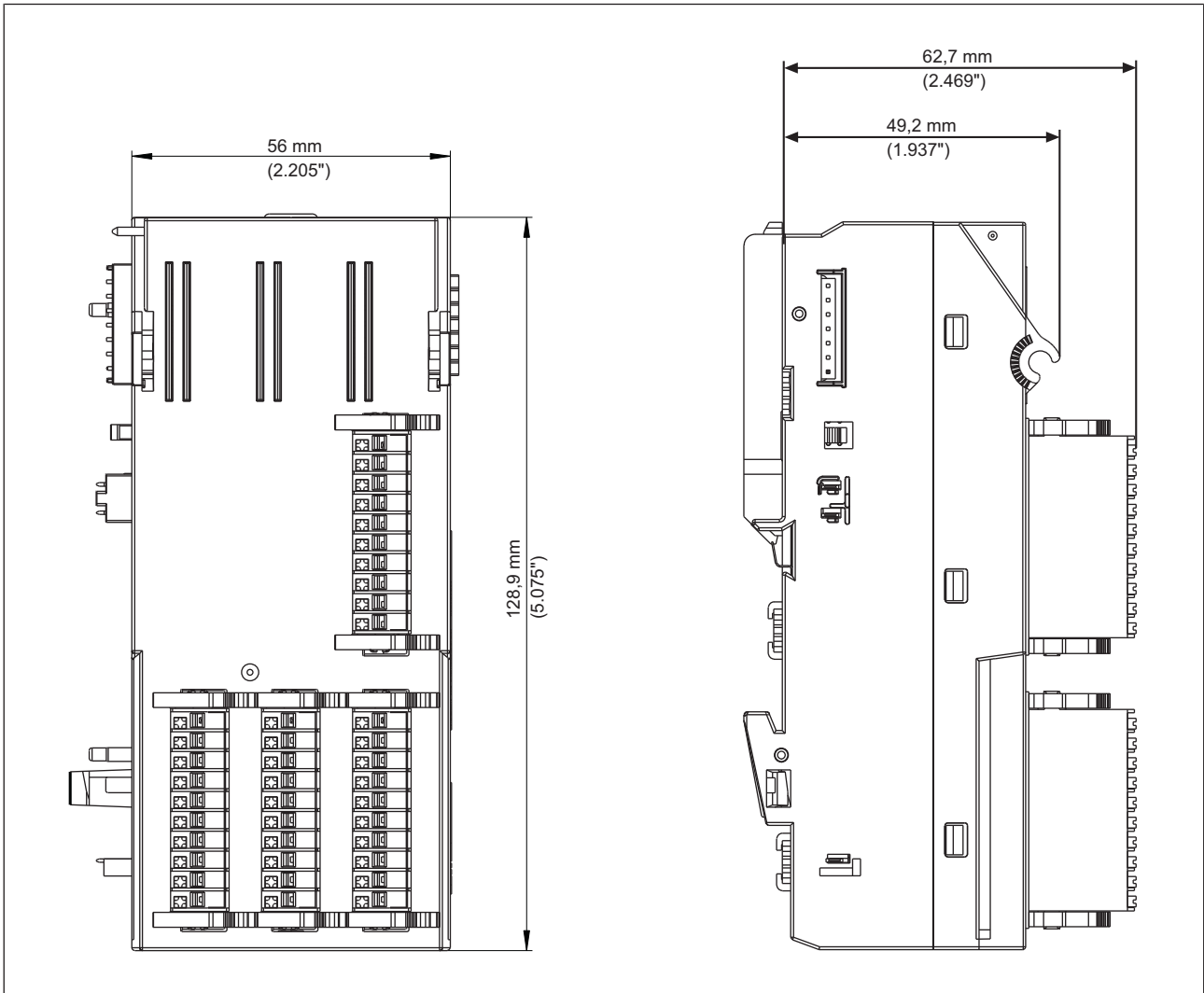

Fig.: Module with connector

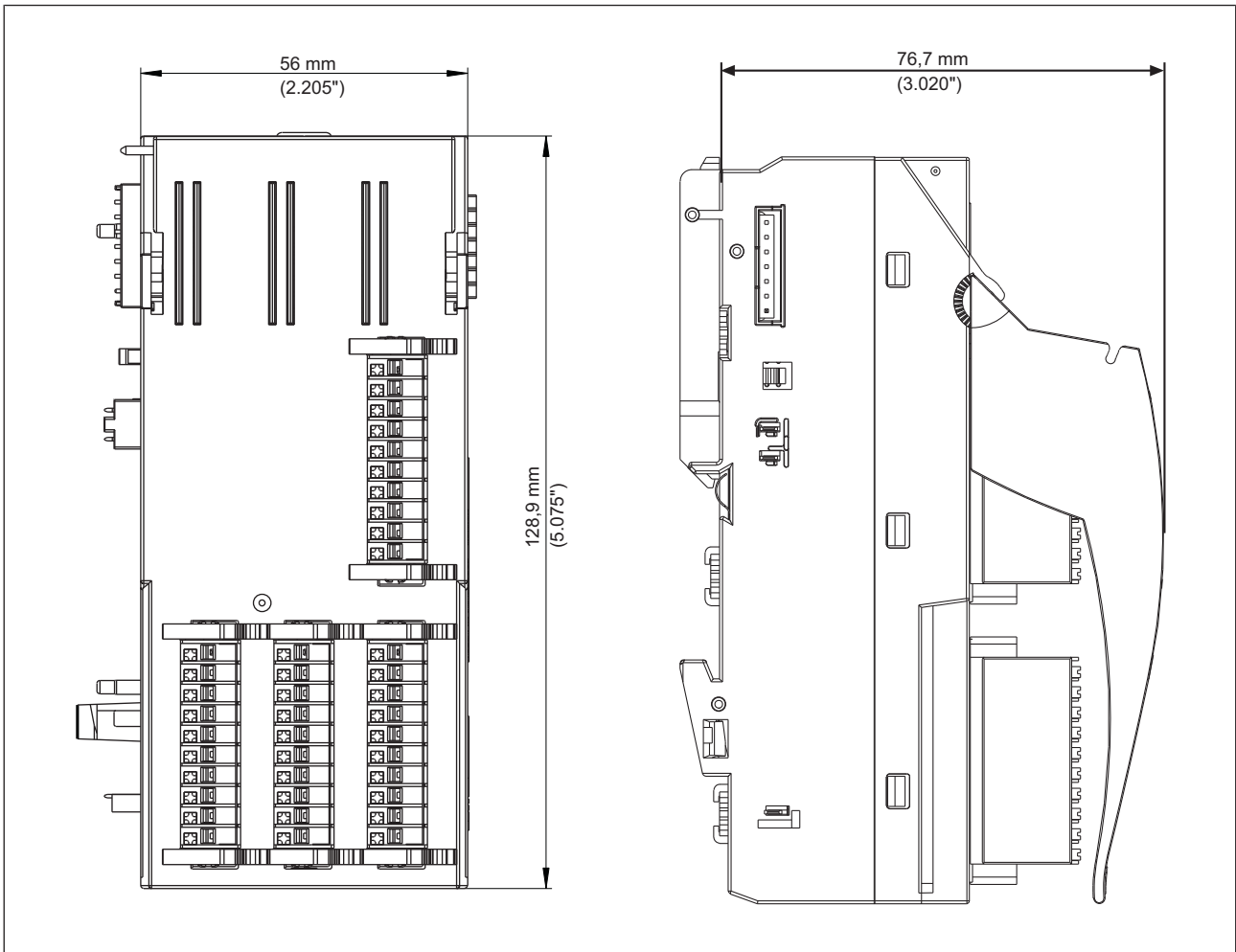

Fig.: Module with connector and labelling bracket

5.2 Install compact module

Prerequisite:

- ▶ The head module must be installed.
- ▶ If the head module does not have an integrated power supply, a supply voltage module must be installed to the right of the head module.
- ▶ A base module with screw terminals may not be installed to the left of the compact module.

Please note:

- ▶ All contacts should be protected from contamination.
- ▶ The mechanics of the compact modules are designed for 50 plug in/out cycles.

Procedure:

- ▶ Slot the groove on the compact module on to the mounting rail from below [1].
- ▶ Push the compact module back as far as it will go [2].
- ▶ Make sure that the locking mechanism [3] is pushed downwards, connecting the module firmly to the mounting rail.
- ▶ On the mounting rail, slide the compact module to the left.



NOTICE

Potential contact damage due to twisting!

The contacts for the Module Supply and Periphery Supply can be bent by twisting the compact modules on the mounting rail.

- On the mounting rail, carefully slide the compact module to the left, in parallel to the adjoining module, until you hear the lateral mounting hooks on the adjacent module lock into position [4].

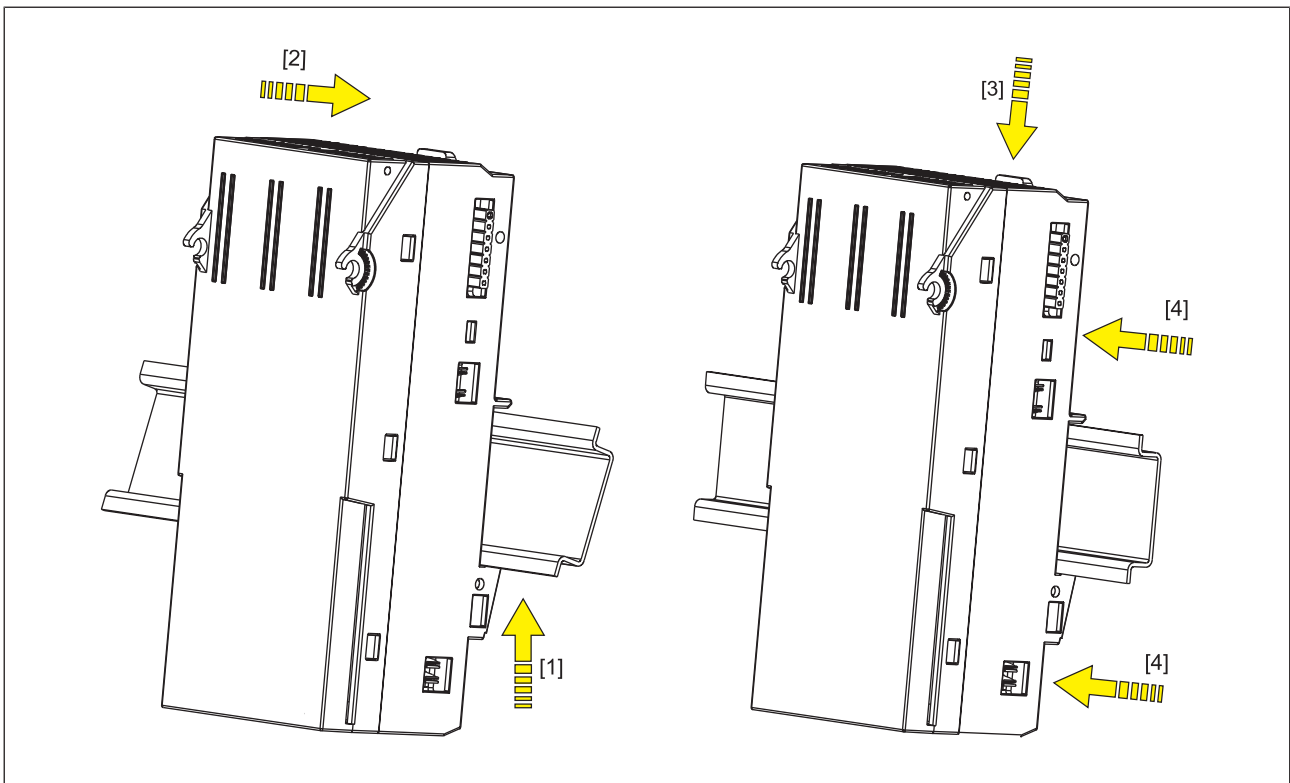

Fig.: Install compact module

5.3 Install/uninstall connector

We recommend that the connectors with spring-loaded terminals are wired before they are plugged in.

Please note:

- ▶ All contacts should be protected from contamination.
- ▶ The mechanics of the connector are designed for 25 plug in/out cycles.

Installation procedure:

- ▶ Plug the connector into the required connector strip until you hear it lock into position [1].



INFORMATION

The two locking levers automatically hook into place when plugged in. As a result the connector is firmly connected to the module.

Uninstallation procedure:

- ▶ Push both locking levers to the left, as far as they will go [1].



INFORMATION

This will automatically lift the connector, which can then be removed from the module.



NOTICE

As you remove the connector, grasp the connector housing and not the cable harness.

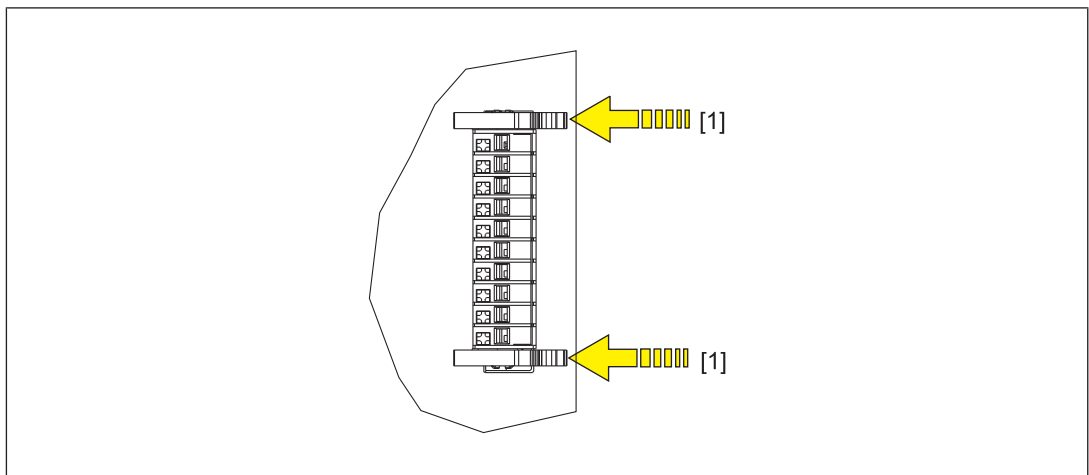

Fig.: Install/uninstall connector

5.4 Install labelling bracket

Installation procedure:

- ▶ We recommend that the labelling strips are attached to the labelling bracket prior to installation.
- ▶ Slot the two pins on the labelling bracket into the receiving lugs on the module [1].
- ▶ Check that the labelling bracket is firmly seated.

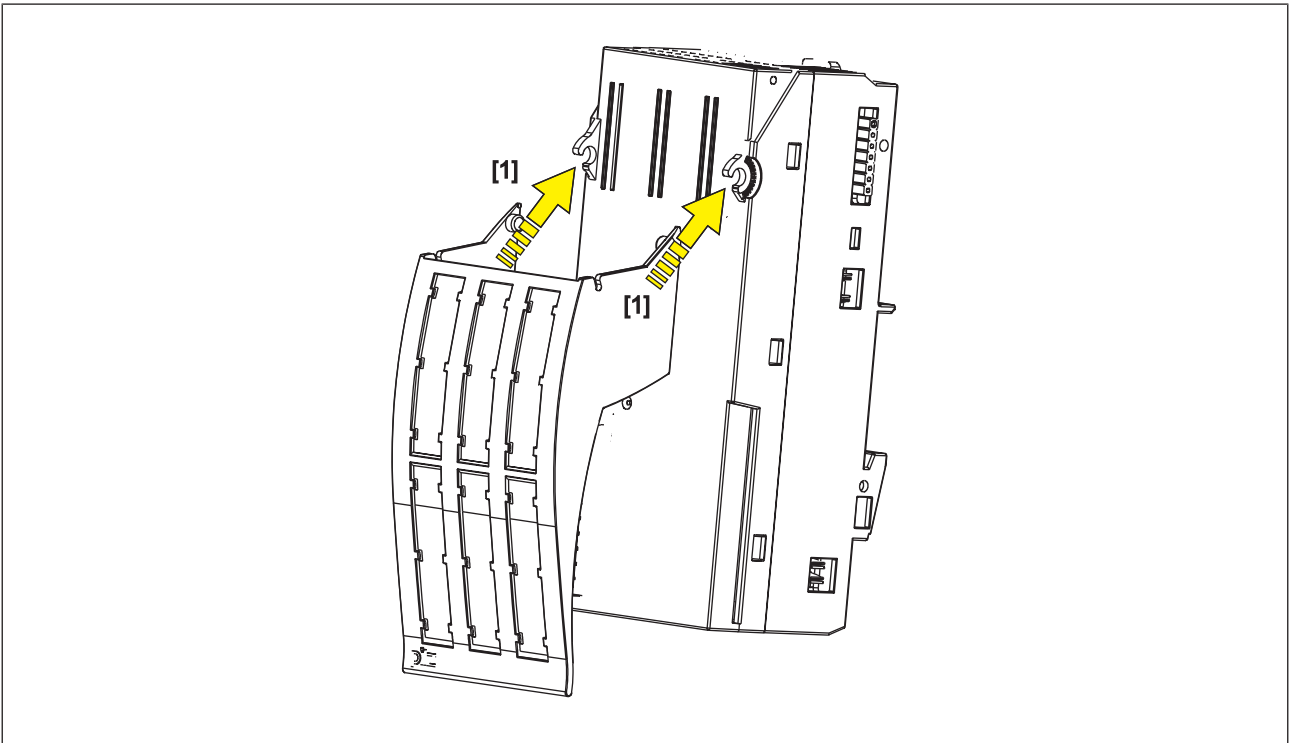

Fig.: Install labelling bracket

6 Wiring

6.1 General wiring guidelines

Please note:

- ▶ Signal lines do not have to be shielded.
- ▶ The outputs do not need suppression for inductive loads.
- ▶ Use copper wiring.

6.2 Connectors' mechanical connection

Please note:

- ▶ The conductor cross section on the spring-loaded terminals without ferrules is 0,2 - 1 mm², 22 - 18 AWG.
- ▶ If you are using multi-core or fine-core cables we recommend ferrules in accordance with DIN 46228/Part 1 or DIN 46228/Part 4, 0.2 ... 1 mm². To crimp the ferrules we recommend crimping pliers (crimp form A) conforming to EN 60947-1, such as the PZ 6/5 from Weidmüller, for example.
- ▶ Terminal points per connection: 1
- ▶ Stripping length: 8 mm

6.3 Connect/disconnect the cables

We recommend you use a screw driver with a 0.4 x 2.5 mm (DIN 5264) blade!

Strip the cable:

- ▶ Strip the cable [1] and apply a ferrule if necessary (DIN 46228/Part 1 or DIN 46228/Part 4).

Connect cable:

- ▶ Using the screwdriver, press the actuator button on the spring-loaded terminal down as far as it will go [2], keep it held down and insert the stripped cable into the plug connection as far as it will go [2].
- ▶ Check that the cable is firmly seated [3].

Disconnect cable:

- ▶ Using the screwdriver, press the actuator button down as far as it will go [4], keep it held down and pull the cable out of the plug connection [4].

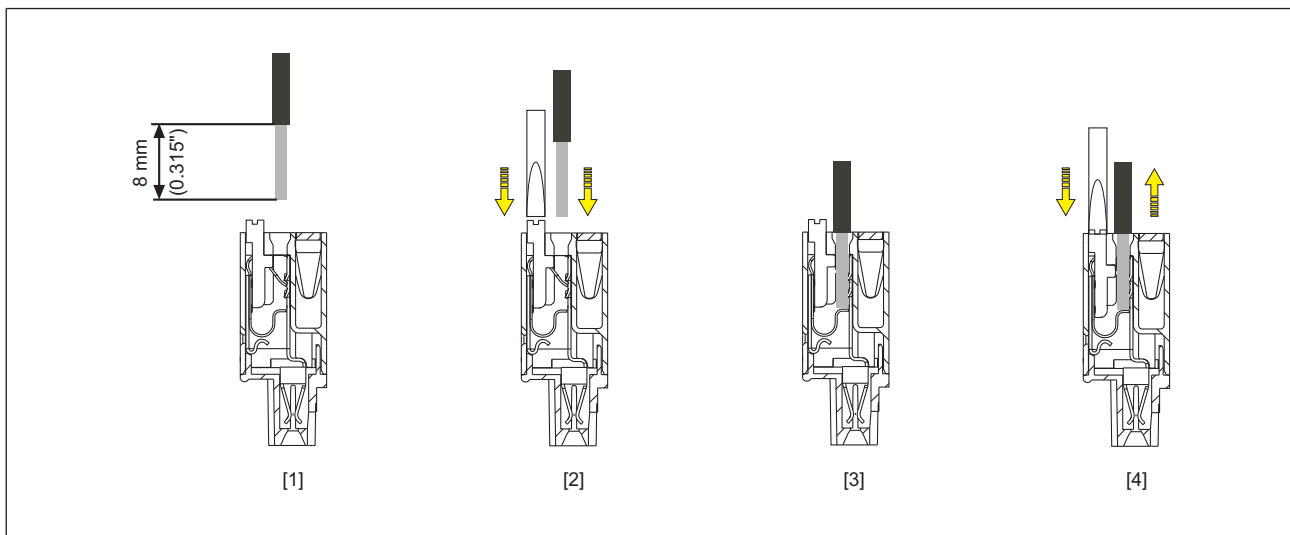

Fig.: Connect and disconnect the cables

6.4 Terminal configuration

Output terminals of connectors with spring-loaded terminals (1-row/10-pin): PSSu A Con 1/10 C	
<p>X12: 24 V >: +24 V (external periphery supply) O 00+: Output 1, dual-pole positive-switching O 00+: Output 1, dual-pole positive-switching O 00-: Output 1, dual-pole negative-switching O 00-: Output 1, dual-pole negative-switching O 01+: Output 2, dual-pole positive-switching O 01+: Output 2, dual-pole positive-switching O 01-: Output 2, dual-pole negative-switching O 01-: Output 2, dual-pole negative-switching 0 V >: 0 V (external periphery supply)</p>	
<p>X22: 24 V >: +24 V (external periphery supply) O 02: Output 0 O 02: Output 0 O 03: Output 1 O 03: Output 1 0 V <: 0 V (periphery supply) 0 V <: 0 V (periphery supply) 0 V <: 0 V (periphery supply) 0 V <: 0 V (periphery supply) 0 V >: 0 V (external periphery supply)</p>	

**Input pin assignment of connectors with spring-loaded terminals (1-row/10-pin):
PSSu A Con 1/10 C**

X31:
 n.c.: not connected
 I 00: Input 0
 I 01: Input 1
 I 02: Input 2
 I 03: Input 3
 I 04: Input 4
 I 05: Input 5
 I 06: Input 6
 I 07: Input 7
 0 V <: 0 V (periphery supply)

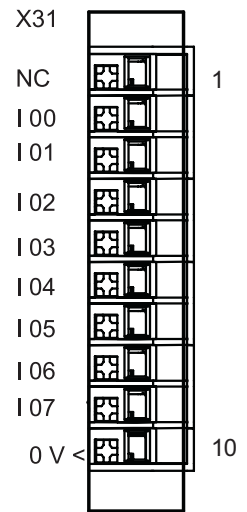

X32:
 NC.: not connected
 I 08: Input 8
 I 09: Input 9
 I 10: Input 10
 I 11: Input 11
 T 00: Test pulse output T0
 or +24 V output (periphery supply)
 T 00: Test pulse output T0
 or +24 V output (periphery supply)
 T 01: Test pulse output T1
 or +24 V output (periphery supply)
 T 01: Test pulse output T1
 or +24 V output (periphery supply)
 0 V <: 0 V (periphery supply)

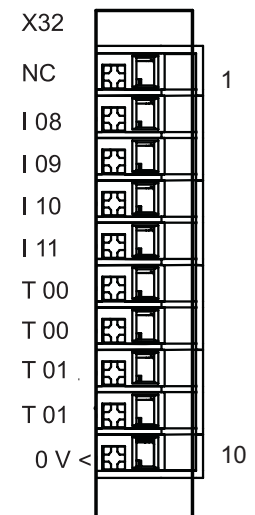

6.5 Connecting the module

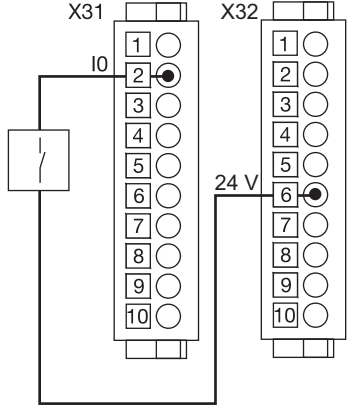
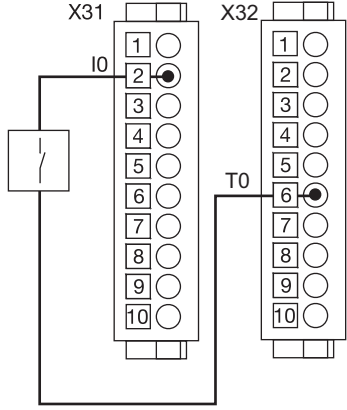
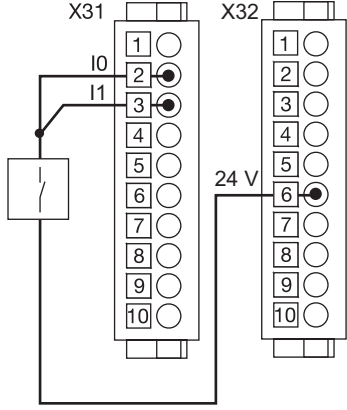
Input circuit for pulse stretching	Wiring
<ul style="list-style-type: none"> ▶ 1-channel sensor ▶ Without input pairs ▶ Without test pulse ▶ Maximum processing time t_{ProclM}: $t_{\text{ProclM}} = t_{\text{Filter}} + 500 \mu\text{s}$ 	
<ul style="list-style-type: none"> ▶ 1-channel sensor ▶ Without input pairs ▶ With test pulse ▶ Maximum processing time t_{ProclM}: $t_{\text{ProclM}} = t_{\text{Filter}} + 2000 \mu\text{s}$ 	
<ul style="list-style-type: none"> ▶ 1-channel sensor ▶ With input pairs ▶ Without test pulse ▶ Maximum processing time t_{ProclM}: $t_{\text{ProclM}} = t_{\text{Filter}} + 200 \mu\text{s}$ 	

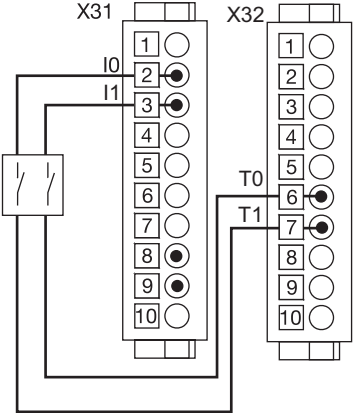
Input circuit for pulse stretching	Wiring
<ul style="list-style-type: none"> ▶ 2-channel sensor ▶ With input pairs ▶ With test pulse ▶ Maximum processing time t_{ProclM}: $t_{\text{ProclM}} = t_{\text{Filter}} + 200 \mu\text{s}$ ▶ Please note that errors in one of the two channels for signals less than $200 \mu\text{s}$ cannot be detected safely. For signal times less than $2000 \mu\text{s}$ the sensor must be included in the safety assessment as a 1-channel sensor. ▶ The signals from a 2-channel sensor with two N/O contacts must be logic AND-linked in the user program. ▶ The signals from a 2-channel sensor with two N/C contacts must be logic OR-linked in the user program. 	

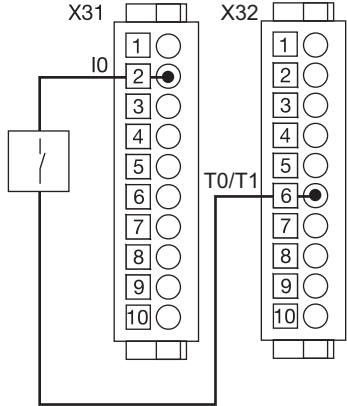
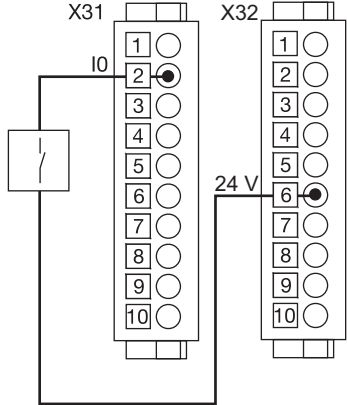
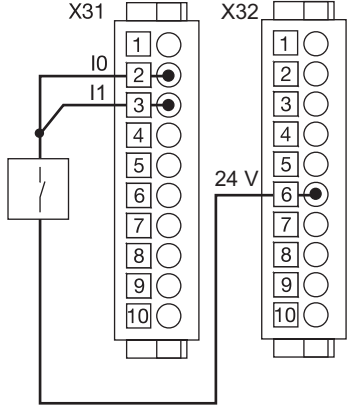
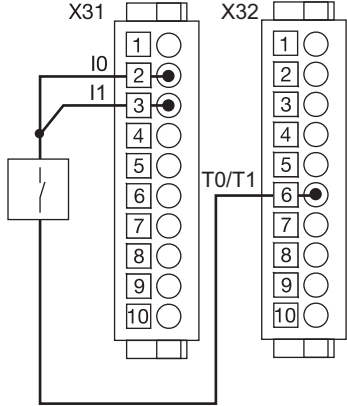
Input circuit for fast shutdown	Wiring
<ul style="list-style-type: none"> ▶ 1-channel sensor ▶ Without input pairs ▶ With test pulse ▶ Maximum processing time t_{ProclM}: $t_{\text{ProclM}} = t_{\text{Filter}} + 2500 \mu\text{s}$ 	
<ul style="list-style-type: none"> ▶ 1-channel sensor ▶ Without input pairs ▶ Without test pulse ▶ Maximum processing time t_{ProclM}: $t_{\text{ProclM}} = t_{\text{Filter}} + 500 \mu\text{s}$ 	
<ul style="list-style-type: none"> ▶ 1-channel sensor ▶ With input pairs ▶ Without test pulse ▶ Rising edge: Maximum processing time t_{ProclM}: $t_{\text{ProclM}} = t_{\text{Filter}} - 100 \mu\text{s}$ ▶ Falling edge: Maximum processing time t_{ProclM}: $t_{\text{ProclM}} = t_{\text{Filter}}$ 	
<ul style="list-style-type: none"> ▶ 1-channel sensor ▶ With input pairs ▶ With test pulse ▶ Maximum processing time t_{ProclM}: $t_{\text{ProclM}} = t_{\text{Filter}} + 2500 \mu\text{s}$ 	

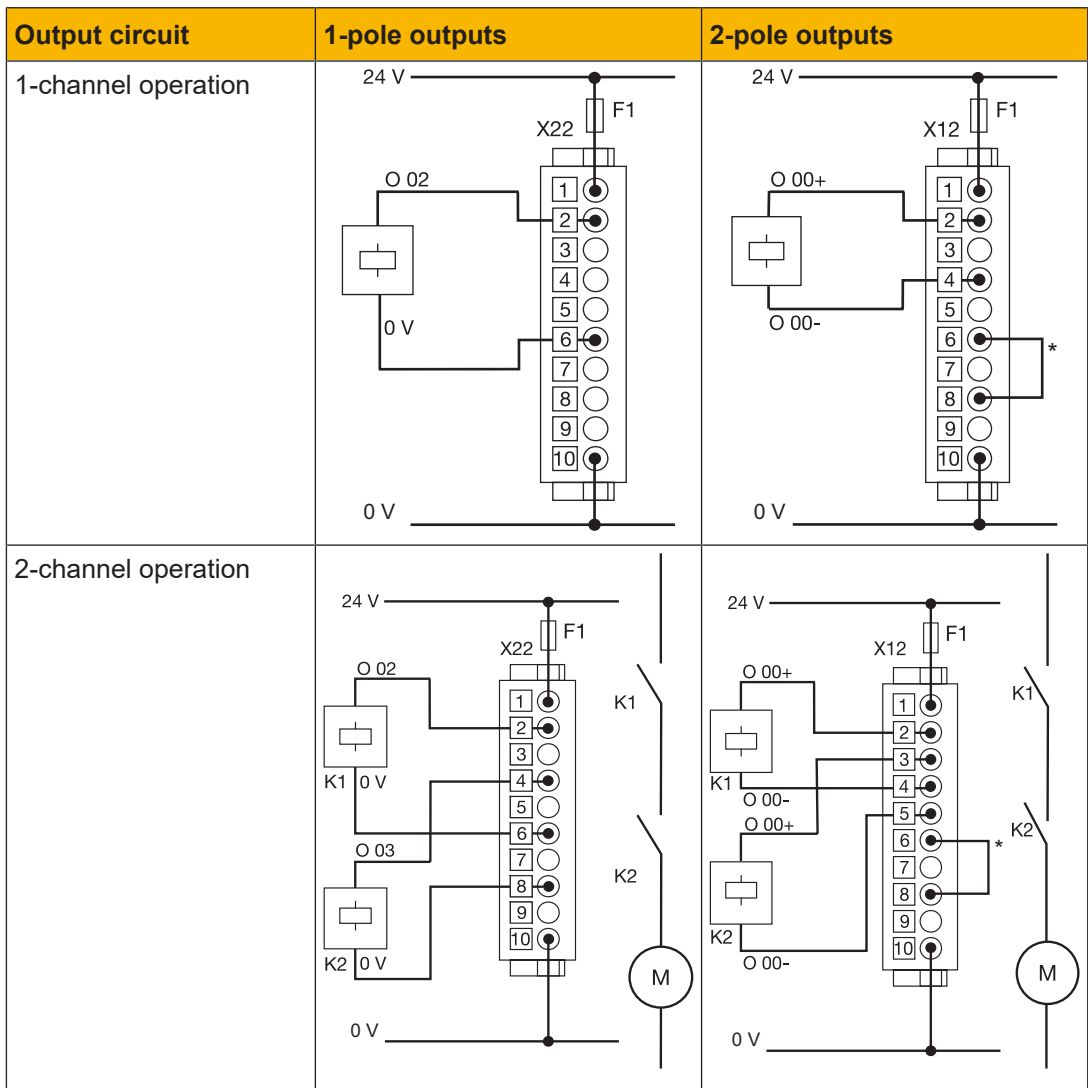
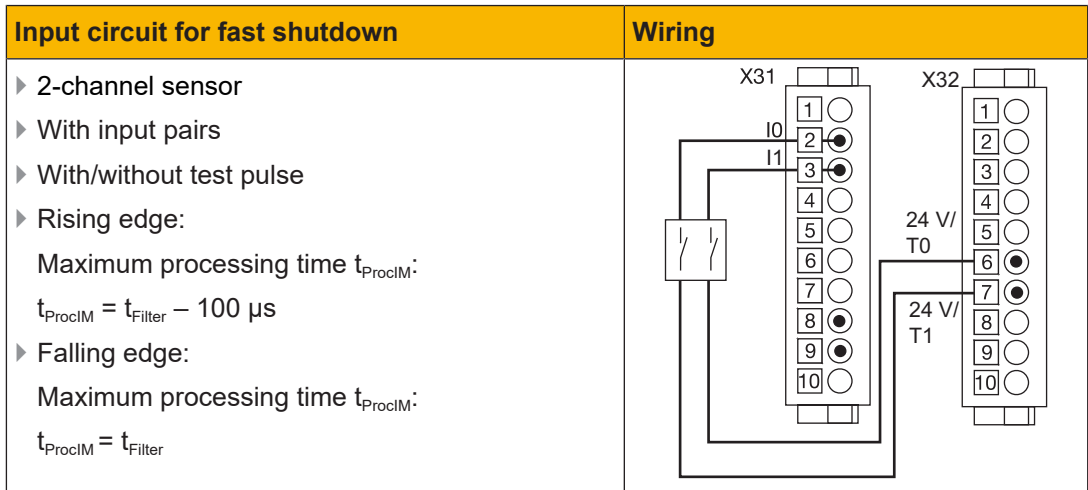

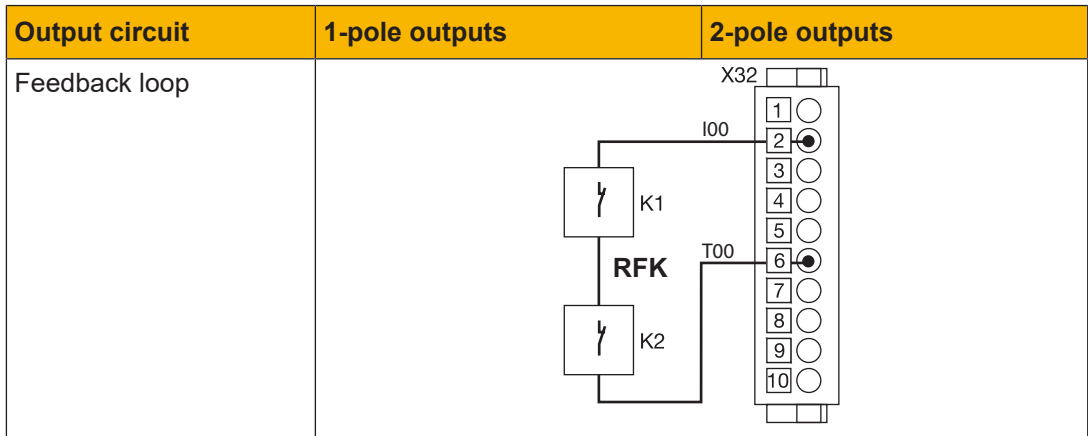

* Place a jumper between unused 2-pole outputs, because otherwise an open circuit will be detected between these outputs.

On dual-pole outputs, both terminals (O00 +/- or O01 +/-) must be used from an output current of 2.18 A per load.

6.6 Function test during commissioning

An error must be simulated for each safety-related output during commissioning: The anticipated error reaction must occur when an output has a short circuit to a supply voltage.



INFORMATION

The short circuit test must be performed on the load and not on the output terminal.

7 Operation

7.1 Messages



A module error is displayed via the "Err" LED, signalled to the head module and then entered in the head module's diagnostic log.

The module can detect the following errors:

Module error	Statement	Remedy
Start-up error	Error as the PSSu system starts up	Change faulty module.
Configuration error	Incorrect module type configured.	The configured hardware registry does not match the actual hardware registry.
FS communication error	Error during FS communication	Change faulty module.
Bus termination error	There is no terminating plate or there is a bad contact with the module bus.	Install a terminating plate with integrated end bracket or insert the base modules together correctly.
Temperature error: too warm	Ambient temperature too high: Error stack entry/diagnostic log entry	Ensure there is sufficient ventilation in the control cabinet or prevent overload.
Input error	Error during the cyclical input test. Possible cause: Input defective.	Change faulty module.
Output error	Error during cyclical output test for short circuit. Possible causes: Short circuit, or output defective, open circuit with dual-pole outputs (open circuit is not displayed via the "Err" LED).	Rectify the open circuit, short circuit or change the faulty module.
Test pulse error	Possible causes: Short circuit between a test pulse and a supply voltage, or a defective module.	Rectify the short circuit or change the faulty module.



7.2 Display elements

Legend

-  LED on
-  LED flashes
-  LED off

7.2.1 Display elements for module diagnostics

The module has an LED for displaying operating states ("On" LED) and module errors ("Err" LED).

LED	LED		Meaning
	Designation	Colour	
On	---	●	Module is not in operation
		Green	
Err	---	●	No error
		Red	
	Red		External error on the inputs/outputs or in the supply voltage for the periphery supply

7.2.2 Display elements for input and output status

Each input and output is assigned an LED to display the status

LED			Meaning	
Description	Colour	Status	Signal	Output
O00	---	●	0 signal	dual-pole O00+
	Green	☀	1 signal	
O01	---	●	0 signal	O 01+
	Green	☀	1 signal	
O02	---	●	0 signal	Single-pole O 02
	Green	☀	1 signal	
O03	---	●	0 signal	O03
	Green	☀	1 signal	
Description	Colour	Status	Signal	Input
I00	---	●	0 signal	With fast shutdown/ pulse stretching
	Green	☀	1 signal	
I07	---	●	0 signal	Without fast shut-down/ pulse stretching
	Green	☀	1 signal	
I08	---	●	0 signal	Without fast shut-down/ pulse stretching
	Green	☀	1 signal	
I11	---	●	0 signal	Without fast shut-down/ pulse stretching
	Green	☀	1 signal	

8 Technical details

Where standards are undated, the 2022-01 valid editions apply.

General	
Certifications	CE, EAC, KOSHA, TÜV, UKCA, cULus Listed
Application range	Failsafe
Module's device code	0E01h
Number of FS input bits	12
Number of FS output bits	4
Number of FS status bits	8
Number of FS control bits	4
Application in system environment B from FS firmware version, head modules	1.7.0
Electrical data	
Supply voltage	
for	Module supply
Voltage	5 V
Kind	DC
Voltage tolerance	-4 %/+4 %
Max. continuous current that the external power supply must provide	0,3 A
Output of external power supply (DC)	1,3 W
Supply voltage	
for	Periphery supply
Voltage	24 V
Kind	DC
Voltage tolerance	-30 %/+25 %
Max. continuous current that the external power supply must provide	0,5 A
Output of external power supply (DC)	12 W
Supply voltage	
for	Outputs
Voltage	24 V
Kind	DC
Voltage tolerance	-30 %/+25 %
Max. continuous current that the external power supply must provide	10 A
Internal supply voltage (module supply)	
Module's power consumption	1,25 W
Periphery's supply voltage (periphery supply)	
Voltage range	16,8 - 30 V
Module's current consumption with no load	8 mA
Module's power consumption with no load	0,19 W
Max. power dissipation of module	7,15 W
Inputs	
Quantity	12

Inputs	
Input current range	2,5 - 7,5 mA
Min. threshold voltage when signal changes from "1" to "0"	9 V
Max. threshold voltage when signal changes from "0" to "1"	10 V
Max. processing time of input in "pulse stretching" mode when signal changes from "0" to "1" (depending on the configured input filter time)	400 ... 5300 µs
Max. processing time of input in "pulse stretching" mode when signal changes from "1" to "0" (depending on the configured input filter time)	400 ... 5300 µs
Max. processing time of input in "rapid shutdown" mode when signal changes from "0" to "1" (depending on the configured input filter time)	100 ... 5800 µs
Max. processing time of input in "rapid shutdown" mode when signal changes from "1" to "0" (depending on the configured input filter time)	200 ... 5800 µs
Potential isolation between input and internal module bus voltage	Yes
Semiconductor outputs	
Output	O0 ... O3
Number of positive-switching single-pole semiconductor outputs	2
Voltage	24 V
Typ. output current at "1" signal and rated voltage of semiconductor output	2 A
Permitted current range	0,000 - 2,500 A
Residual current at "0" signal	0,02 A
Max. transient pulsed current	6 A
Max. internal voltage drop	100 mV
Monitoring threshold of semiconductor output	9 V
Max. duration of on time during self test	200 µs
Max. duration of off time during self test	200 µs
Max. processing time of semiconductor output when signal changes from "1" to "0"	0,25 ms
Max. processing time of semiconductor output when signal changes from "0" to "1"	0,45 ms
Potential isolation from system voltage	Yes
Potential isolation between semiconductor output and input	Yes
Short circuit-proof	Yes
Permitted loads	inductive, capacitive, resistive
Semiconductor outputs, 2-pole	
Number of dual-pole semiconductor outputs	2
Permitted loads	0,00 - 3,50 A
Terminal voltage when switching off inductive loads	-185 V
Typ. output current at "1" signal and rated voltage of semiconductor output	3 A

Semiconductor outputs, 2-pole	
Residual current at "0" signal	0,02 A
Max. pulsed current for $t < 100$ ms	12 A
Open circuit detection off	0,17 kOhm
Potential isolation	Yes
Short circuit-proof	Yes
Permitted loads	inductive, capacitive, resistive
Monitoring threshold of semiconductor output	9 V
Max. duration of on time during self test	4 ms
Max. duration of off time during self test	400 μs
Max. processing time of semiconductor output when signal changes from "0" to "1"	9,3 ms
Max. processing time of semiconductor output when signal changes from "1" to "0"	0,25 ms
Test pulse outputs	
Number of test pulse outputs	2
Voltage, test pulse outputs	24 V DC
Short circuit-proof	Yes
Number of outputs that can be configured as test pulses	2
Max. output current at "1" signal	0,25 A
Max. cable length between test pulse output and input	200 m
Standard for voltage interruptions	EN 61131-2
Times	
Max. reaction time of fast shutdown when signal changes from "1" to "0"	0,45 - 6,05 ms
Max. reaction time of fast shutdown when signal changes from "0" to "1"	0,35 - 6,05 ms
Environmental data	
Climatic suitability	EN 60068-2-1, EN 60068-2-14, EN 60068-2-2, EN 60068-2-30, EN 60068-2-78
Ambient temperature	
in accordance with the standard	EN 60068-2-14
Temperature range	0 - 60 °C
Storage temperature	
in accordance with the standard	EN 60068-2-1/-2
Temperature range	-25 - 70 °C
Climatic suitability	
in accordance with the standard	EN 60068-2-78
Humidity	93 % r. h. at 40 °C
Condensation during operation	Not permitted
Max. operating height above SL	2000 m
EMC	EN 61000-6-2, EN 61000-6-4, EN 61131-2 (Zone B)

Environmental data

Vibration

in accordance with the standard	EN 60068-2-6
Frequency	10 - 150 Hz
Acceleration	10 m/s²

Shock stress

in accordance with the standard	EN 60068-2-27
Acceleration	150 m/s²
Duration	11 ms

Airgap creepage

in accordance with the standard	EN 61131-2
Overvoltage category	II
Pollution degree	2

Protection type

in accordance with the standard	EN 60529
Housing	IP20
Mounting area (e.g. control cabinet)	IP54

Mechanical data

Material

Bottom	PC
Front	PC
Labelling bracket (accessories)	PC

Connection type **Connector strip**

Mounting type **plug-in**

Conductor cross section with spring-loaded terminals:

Flexible with/without crimp connector **0,2 - 1 mm², 22 - 18 AWG**

Spring-loaded terminals: Terminal points per connection

1

Stripping length with spring-loaded terminals

8 mm

Dimensions

Height	128,9 mm
Width	56 mm
Depth	56 mm
Depth incl. connector (accessories)	69,5 mm
Depth incl. labelling bracket (accessories)	83,5 mm

Weight

170 g

8.1 Safety characteristic data



NOTICE

You must comply with the safety characteristic data in order to achieve the required safety level for your plant/machine.

Unit	Operating mode	EN ISO 13849-1: 2015 PL	EN ISO 13849-1: 2015 Category	EN IEC 62061 SIL CL/ max. SIL	EN IEC 62061 61508 PFH _D [1/h]	EN/IEC 61511 61508 SIL	EN/IEC 61511 61508 PFD	EN ISO 13849-1: 2015 T _M [year]
------	----------------	----------------------------	----------------------------------	-------------------------------------	---	------------------------------	------------------------------	---

Logic

Logic	2-channel	PL e	Cat. 4	SIL CL 3	1,36E-10	SIL 3	1,17E-05	20
-------	-----------	------	--------	----------	----------	-------	----------	----

Input

Digital inputs	1-channel	PL d	Cat. 2	SIL CL 2	3,55E-09	SIL 2	3,11E-04	20
----------------	-----------	------	--------	----------	----------	-------	----------	----

Digital inputs	2-channel	PL e	Cat. 4	SIL CL 3	7,31E-11	SIL 3	6,35E-06	20
----------------	-----------	------	--------	----------	----------	-------	----------	----

Digital inputs	1-ch., pulsed light barrier	PL e	Cat. 4	SIL CL 3	3,55E-10	SIL 3	3,14E-05	20
----------------	-----------------------------------	------	--------	----------	----------	-------	----------	----

Output

SC outputs (1-pole)	1-channel	PL d	Cat. 2	SIL CL 2	3,95E-09	SIL 2	3,46E-04	20
---------------------	-----------	------	--------	----------	----------	-------	----------	----

SC outputs (1-pole)	2-channel	PL e	Cat. 4	SIL CL 3	8,17E-11	SIL 3	7,08E-06	20
---------------------	-----------	------	--------	----------	----------	-------	----------	----

SC outputs (2-pole)	2-channel	PL e	Cat. 4	SIL CL 3	7,85E-11	SIL 3	6,81E-06	20
---------------------	-----------	------	--------	----------	----------	-------	----------	----

Explanatory notes for the safety-related characteristic data:

- ▶ T_M is the maximum mission time in accordance with EN ISO 13849-1. The value also applies as the retest interval in accordance with EN/IEC 61508-6 and EN/IEC 61511 and as the proof test interval and mission time in accordance with EN IEC 62061

All the units used within a safety function must be considered when calculating the safety characteristic data.



INFORMATION

A safety function's SIL/PL values are **not** identical to the SIL/PL values of the units that are used and may differ from these.

9 Order reference

9.1 Product

Product type	Features	Order no.
PSSu K F FCU	Compact module	312435

9.2 Accessories

Terminals

Product type	Features	Order no.
PSSu A Con 1/10 C	Connector with spring-loaded terminals 1-row/10-pin, scope of supply: 2 pieces. 2 sets are needed per module (4 pieces)	313115

Labelling

Product type	Features	Order no.
PSSu A LA0	Labelling strips, laser printable, scope of delivery: 1080 pieces (10 x DIN A4 sheet, 108 on each)	312958

10 **EC declaration of conformity**

This product/these products meet the requirements of the directive 2006/42/EC on machinery of the European Parliament and of the Council. The complete EC Declaration of Conformity is available on the Internet at www.pilz.com/downloads.

Representative: Pilz GmbH & Co. KG, Felix-Wankel-Str. 2, 73760 Ostfildern, Germany

11 UKCA-Declaration of Conformity

This product(s) complies with following UK legislation: Supply of Machinery (Safety) Regulation 2008.

The complete UKCA Declaration of Conformity is available on the Internet at www.pilz.com/downloads.

Representative: Pilz Automation Technology, Pilz House, Little Colliers Field, Corby, Northamptonshire, NN18 8TJ United Kingdom, eMail: mail@pilz.co.uk

► Support

Technical support is available from Pilz round the clock.

Americas

Brazil

+55 11 97569-2804

Canada

+1 888 315 7459

Mexico

+52 55 5572 1300

USA (toll-free)

+1 877-PILZUSA (745-9872)

Asia

China

+86 400-088-3566

Japan

+81 45 471-2281

South Korea

+82 31 778 3300

Australia and Oceania

Australia

+61 3 95600621

New Zealand

+64 9 6345350

Europe

Austria

+43 1 7986263-444

Belgium, Luxembourg

+32 9 3217570

France

+33 3 88104003

Germany

+49 711 3409-444

Ireland

+353 21 4804983

Italy, Malta

+39 0362 1826711

Scandinavia

+45 74436332

Spain

+34 938497433

Switzerland

+41 62 88979-32

The Netherlands

+31 347 320477

Türkiye

+90 216 5775552

United Kingdom

+44 1536 462203

You can reach our international hotline on:

+49 711 3409-222

support@pilz.com

Pilz develops environmentally-friendly products using ecological materials and energy-saving technologies. Offices and production facilities are ecologically designed, environmentally-aware and energy-saving. So Pilz offers sustainability, plus the security of using energy-efficient products and environmentally-friendly solutions.



We are represented internationally. Please refer to our homepage www.pilz.com for further details or contact our headquarters.

Headquarters: Pilz GmbH & Co. KG, Felix-Wankel-Straße 2, 73760 Ostfildern, Germany
Telephone: +49 711 3409-0, E-Mail: info@pilz.com, Internet: www.pilz.com

PILZ
THE SPIRIT OF SAFETY

CECE[®], CHRE[®], CMSE[®], INDUSTRIAL P[®], Leansafe[®], Myzei[®], PAS4000[®], PASscal[®], PASconfig[®], Pilz[®], PIT[®], PMSprimo[®], PMSprotego[®], PMCiendo[®], PMD[®], PMI[®], PNOZ[®], Primo[®], PSEN[®], PSS[®], PSS[®], PVIS[®], SafetyBUS p[®], SafetyNET p[®], THE SPIRIT OF SAFETY[®] are registered and protected trademarks of Pilz GmbH & Co. KG in some countries. We would point out that product features may vary from the details stated in this document, depending on the status at the time of publication and the scope of the equipment. We accept no responsibility for the validity, accuracy and entirety of the text and graphics presented in this information. Please contact our Technical Support if you have any questions.

1002391-EN-12, 2024-09 Printed in Germany
© Pilz GmbH & Co. KG, 2019