



▶ PSSu H m F DP SN SD

PILZ

THE SPIRIT OF SAFETY

Operating Manual-1002324-EN-08
- Control system PSSuniversal multi



This document is the original document.

Where unavoidable, for reasons of readability, the masculine form has been selected when formulating this document. We do assure you that all persons are regarded without discrimination and on an equal basis.

All rights to this documentation are reserved by Pilz GmbH & Co. KG. Copies may be made for the user's internal purposes. Suggestions and comments for improving this documentation will be gratefully received.

Pilz®, PIT®, PMI®, PNOZ®, Primo®, PSEN®, PSS®, PVIS®, SafetyBUS p®, SafetyEYE®, SafetyNET p®, the spirit of safety® are registered and protected trademarks of Pilz GmbH & Co. KG in some countries.



SD means Secure Digital

1	Introduction	5
1.1	Validity of the documentation	5
1.1.1	Retaining the documentation	5
1.2	Definition of symbols	5
1.3	Third-party manufacturer licence information	6
2	Overview	7
2.1	Module features	7
2.2	Front view	8
3	Safety	9
3.1	Intended use	9
3.2	Safety regulations	9
3.2.1	Use of qualified personnel	9
3.2.2	Warranty and liability	10
3.2.3	Disposal	10
4	Function description	11
4.1	Block diagram	11
4.2	Control system	11
4.3	Supply voltage	12
4.3.1	Function description	12
4.3.2	Current load capacity	12
4.4	Integrated protection mechanisms	13
4.5	SD card	14
4.6	Reset button	14
4.7	SafetyNET p	15
4.7.1	Connection to SafetyNET p	15
4.8	PROFIBUS DP	15
4.8.1	Connection to PROFIBUS-DP	15
4.8.2	Selector switch for setting the station address	16
5	Installation	17
5.1	General installation guidelines	17
5.2	Dimensions	17
5.3	Installing the head module	18
6	Interfaces	19
6.1	Interface configuration	19
6.1.1	SafetyNET p	19
6.1.2	PROFIBUS DP	19
6.1.2.1	Connection to PROFIBUS DP	20
7	Wiring	21
7.1	General wiring guidelines	21
7.2	Terminal configuration	22
7.3	Connecting the module	22

8	Operation	24
8.1	Messages	24
8.2	Display elements	24
8.2.1	MBUS	25
8.2.2	SD CARD	26
8.2.3	FS RUN	27
8.2.4	DIAG	28
8.2.5	FS FORCE	29
8.2.6	SF, BF	30
8.2.7	ST SNp	31
8.2.8	FS SNp	32
8.2.9	5V, 24V	33
8.2.10	X3: LNK, X3: TRF	34
9	Technical details	35
9.1	Safety characteristic data	39
10	Order reference	40
10.1	Product	40
10.2	Accessories	40
11	EC declaration of conformity	41
12	UKCA-Declaration of Conformity	42

1 Introduction

1.1 Validity of the documentation

This documentation is valid for the product type PSSu H m F DP SN SD. It is valid until new documentation is published.

Please also refer to the following documents:

- ▶ PSS4000 System Description
- ▶ PSSuniversal Installation Manual

This operating manual explains the function and operation, describes the installation and provides guidelines on how to connect the product.

1.1.1 Retaining the documentation

This documentation is intended for instruction and should be retained for future reference.

1.2 Definition of symbols

Information that is particularly important is identified as follows:



DANGER!

This warning must be heeded! It warns of a hazardous situation that poses an immediate threat of serious injury and death and indicates preventive measures that can be taken.



WARNING!

This warning must be heeded! It warns of a hazardous situation that could lead to serious injury and death and indicates preventive measures that can be taken.



CAUTION!

This refers to a hazard that can lead to a less serious or minor injury plus material damage, and also provides information on preventive measures that can be taken.



NOTICE

This describes a situation in which the product or devices could be damaged and also provides information on preventive measures that can be taken. It also highlights areas within the text that are of particular importance.



INFORMATION

This gives advice on applications and provides information on special features.

1.3 Third-party manufacturer licence information

This product includes Open Source software with various licenses.

Further information is available in the document „Third-party manufacturer licence information PSS 4000-exclusive devices“ (document number 1003883) at www.pilz.com.

2 Overview

2.1 Module features

The head module belongs to the performance class "Control system PSSu multi". The head module has the following features:

- ▶ 1 free switch ports for connection to SafetyNET p
- ▶ PROFIBUS DP interface
- ▶ an FS resource
- ▶ SD card used to store the device project and the naming data
- ▶ Reset button
 - For warm reset
 - To transfer the naming data and/or device project from the SD card to the device memory
- ▶ Supply voltage
 - Integrated supply voltage for periphery supply and module supply
 - Module supply is buffered for 20 ms if the supply voltage is interrupted
 - Plug-in connection terminals (either spring-loaded terminal or screw terminal)
- ▶ Status LEDs
- ▶ Supports FS and ST modules

2.2 Front view

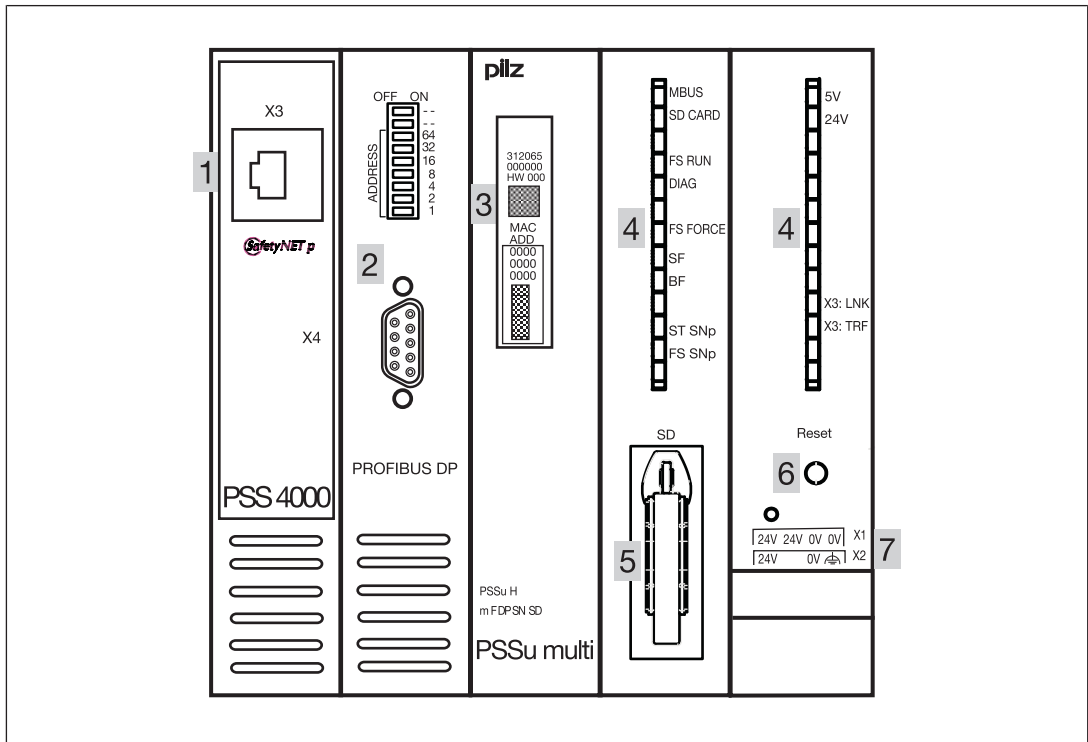

Legend:

- ▶ 1: SafetyNET p interface
- ▶ 2: PROFIBUS DP interface
- ▶ 3: Labelling strip (see below for details)
- ▶ 4: Status LEDs
- ▶ 5: SD card
- ▶ 6: Reset button
- ▶ 7: Supply voltage connection (module and periphery supply)

The labelling strip contains the following information:

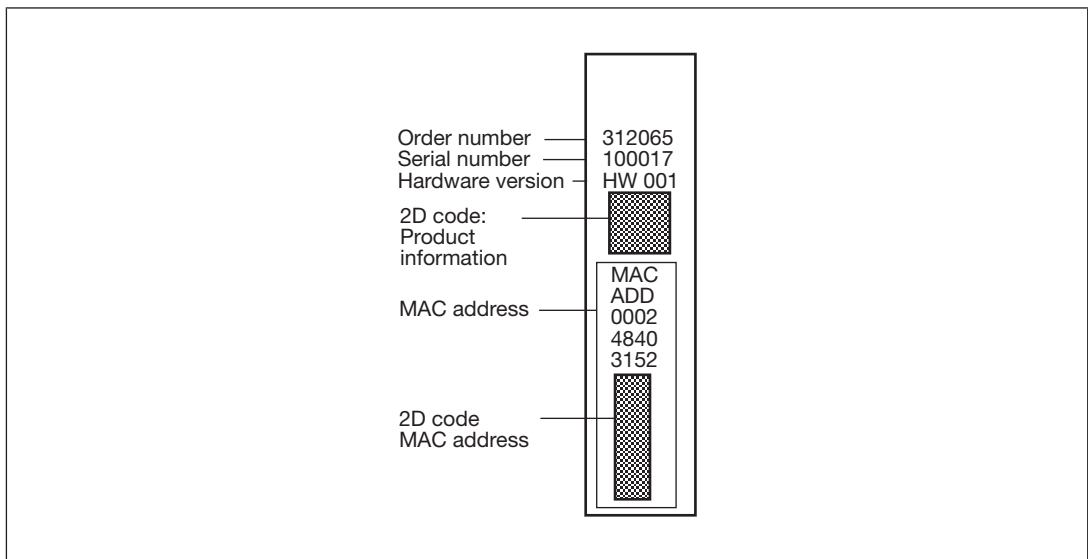

3 Safety

3.1 Intended use

The module is designed for use in:

- ▶ Safety-related applications with
 - SafetyNET p
 - PROFIBUS DP with enable principle
- ▶ Non-safety-related applications with
 - PROFIBUS DP
 - SafetyNET p

Intended use includes making the electrical installation EMC-compliant. Please refer to the guidelines stated in the "PSSuniversal Installation Manual". The module is designed for use in an industrial environment. It is not suitable for use in a domestic environment, as this can lead to interference.

The following is deemed improper use in particular:

- ▶ Any component, technical or electrical modification to the module
- ▶ Use of the module outside the areas described in this manual
- ▶ Any use of the module that is not in accordance with the technical details.



INFORMATION

The module is supported by PAS4000 from Version 1.5.0. We recommend that you always use the latest version (download from www.pilz.de).

3.2 Safety regulations

3.2.1 Use of qualified personnel

The products may only be assembled, installed, programmed, commissioned, operated, maintained and decommissioned by persons who are competent to do so.

A competent person is a qualified and knowledgeable person who, because of their training, experience and current professional activity, has the specialist knowledge required. To be able to inspect, assess and operate devices, systems and machines, the person has to be informed of the state of the art and the applicable national, European and international laws, directives and standards.

It is the company's responsibility only to employ personnel who

- ▶ Are familiar with the basic regulations concerning health and safety / accident prevention,
- ▶ Have read and understood the information provided in the section entitled Safety
- ▶ Have a good knowledge of the generic and specialist standards applicable to the specific application.

3.2.2 **Warranty and liability**

All claims to warranty and liability will be rendered invalid if

- ▶ The product was used contrary to the purpose for which it is intended,
- ▶ Damage can be attributed to not having followed the guidelines in the manual,
- ▶ Operating personnel are not suitably qualified,
- ▶ Any type of modification has been made (e.g. exchanging components on the PCB boards, soldering work etc.).

3.2.3 **Disposal**

- ▶ In safety-related applications, please comply with the mission time T_M in the safety-related characteristic data.
- ▶ When decommissioning, please comply with local regulations regarding the disposal of electronic devices (e.g. Electrical and Electronic Equipment Act).

4 Function description

4.1 Block diagram

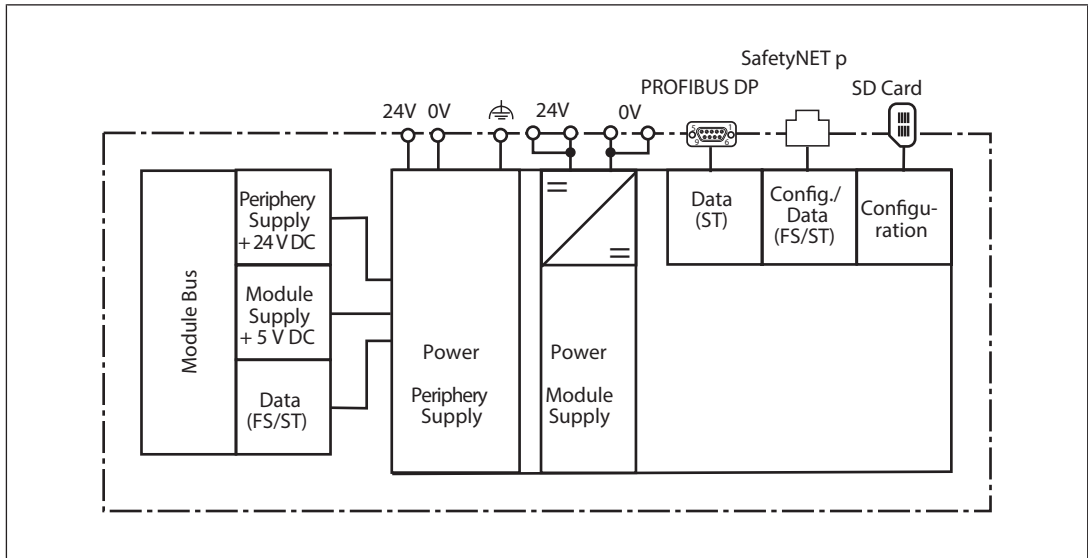

4.2 Control system

The head module is a programmable logic controller (PLC), which can be used in safety-related and non-safety-related applications. The control system has memory areas for the operating system, the data and the device project with the user program.

User programs can be created in Multi programming.

For safety-related applications, the processor section is designed with multi-channel diversity.

The control system communicates with the input and output modules via the local module bus.

LEDs provide information on the status of the control system and indicate any errors.

4.3 Supply voltage

4.3.1 Function description

The product provides the module supply and periphery supply for the modules on the module bus:

▶ Module supply

Supply voltage for subsequent module (right-hand side)

▶ Periphery supply

Supply voltage for sensors, actuators and test pulses

The periphery supply is monitored for undervoltage and overvoltage. The periphery supply does not switch off automatically if levels drop below the limit values. However, the red LED flashes and a message is entered in the diagnostic log.

– Monitored lower voltage value: 16.8 V

– Monitored upper voltage value: 32 V

The maximum time between two voltage measurements is 100 ms.

The maximum time that can elapse between the first time a value exceeds or falls below a voltage value and the reaction of the head module is 100 ms + cycle time of the FS module bus.

When the supply voltage is fed in separately, the module supply and periphery supply are galvanically isolated. If galvanic isolation is not required, a common power supply may be used for the periphery supply and module supply.

4.3.2 Current load capacity

Ensure you comply with the current load capacity of the module and periphery supply (see "Technical Details"). If the current load is higher, an additional supply voltage module is required to refresh the module supply and periphery supply.

▶ Module supply

The current load is the total current consumption of all the electronic and compact modules.

The module supply does not automatically switch off if values exceed or drop below their limits. However, the "5 V" LED will light and a message will be entered in the diagnostic list.

▶ Periphery supply

The current load is the total current consumption of the sensors, actuators and test pulses supplied via the input/output modules.

The periphery supply does not automatically switch off if values exceed or drop below their limits. However, the "24 V" LED will light and a message will be entered in the diagnostic list.

Please refer to the derating diagram.

Derating diagram for periphery supply: Temperature T dependent on load current I

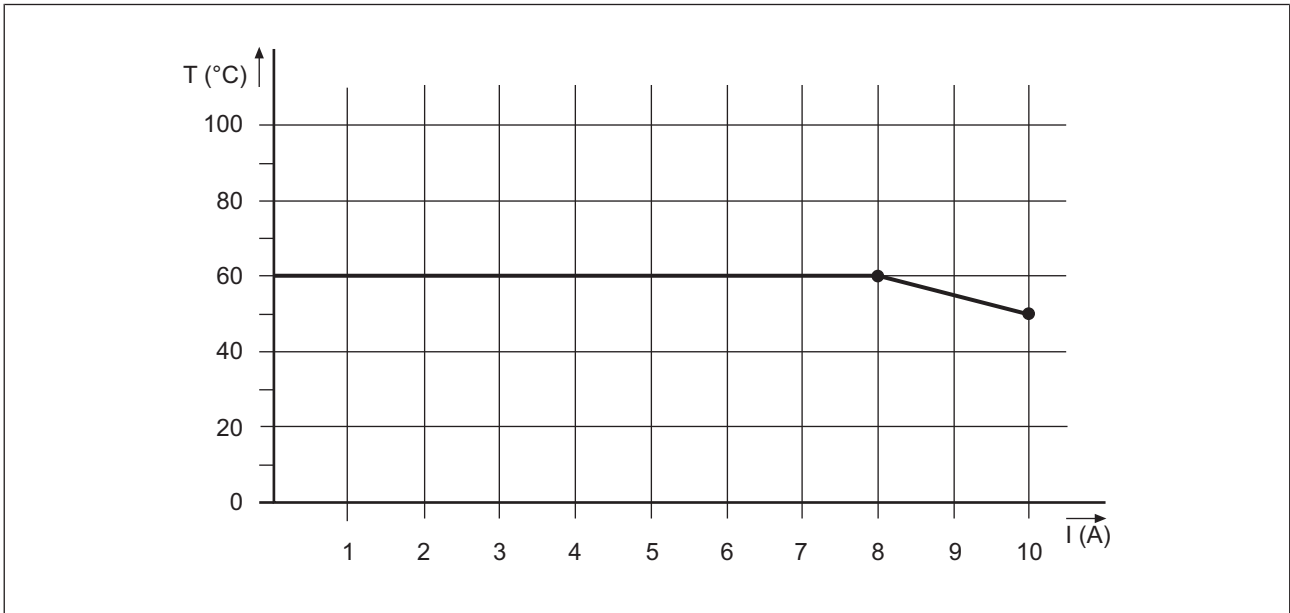

4.4 Integrated protection mechanisms

The module has the following protection mechanisms:

- ▶ Multi-channel diverse processor section
- ▶ Cyclical self tests
- ▶ Potentially isolated **SafetyNET p** interface
- ▶ Potentially isolated PROFIBUS DP interface
- ▶ Infeed for module supply
 - Polarity protection
 - Voltage monitoring
 - Transient voltage limitation
 - 20 ms voltage buffer if the supply voltage is interrupted
- ▶ Module supply
 - Short circuit-proof
- ▶ Periphery supply
 - Voltage monitoring (exceeding upper/lower limit)

4.5 SD card

The SD card has the following functions:

- ▶ The SD card is used to store the naming data and the device project; see PSS 4000 System Description.
- ▶ The SD card is part of the safety concept on PSS 4000. If the SD card is missing or has been swapped, the next time the PSSu system is booted it will be unable to achieve the operating status "PSSu System in RUN condition without error". The SD card has a locking mechanism, which protects it from being removed from the card holder unintentionally. The SD card can also be sealed to protect it from manipulation, whether accidental or intentional.

Sealing the SD card for additional protection:

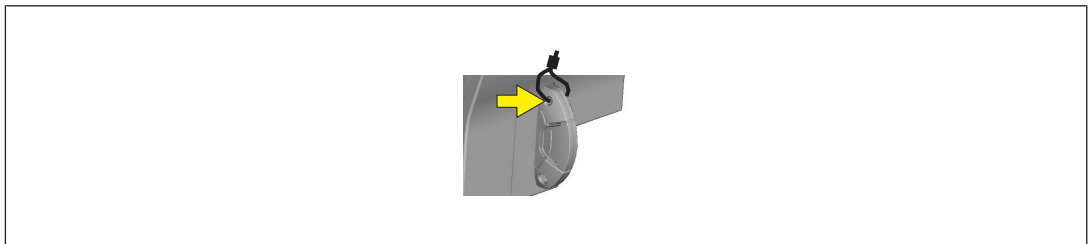

NOTICE

Damage to files on the SD card

Files may be damaged if the card is removed from the device or the power to the device is switched off as the SD card is being written.

Remove the SD card only in recovery mode or in switched-off state.

4.6 Reset button

The "Reset" pushbutton on the head module has various functions:

- ▶ Perform a warm reset for the PSSu system.
The reset pushbutton can be used to perform a warm reset for the PSSu system.
- ▶ Transfer the naming data and/or device project from the SD card (deliberate operator action to transfer the naming data and/or device project from the SD card to the device memory).
- ▶ Perform recovery mode.



INFORMATION

The warm reset and the recovery mode and transfer of the naming data and/or device project are described in the "PSS 4000 System Description". This is also where the general effects on the PSSu system are described in detail.

4.7 SafetyNET p

4.7.1 Connection to SafetyNET p

Functions

- ▶ The SafetyNET p interface enables safety-related and non-safety-related data transfer between the PSSu system and other network subscribers.
- ▶ The head module receives signals from other network subscribers; it processes these signals in the user program and passes them on to the connected input/output modules.
- ▶ The head module receives signals from the connected input/output modules; it processes these signals in the user program and passes them on to the other network subscribers.
- ▶ If a fault occurs, the module switches the connected failsafe outputs to a safe condition.

MAC address

- ▶ The MAC address is a factory-set default. It can be found on the labelling strip on the front of the module.



INFORMATION

Further information on SafetyNET p can be found in the "PSS 4000 System Description".

4.8 PROFIBUS DP

4.8.1 Connection to PROFIBUS-DP

PROFIBUS is an open fieldbus standard whose communication is defined in the international standards IEC 61158 and IEC 61784. Further provisions have been defined in specifications published by the PROFIBUS User Group. These specifications are available from PROFIBUS International (see www.profibus.com).

4.8.2 Selector switch for setting the station address

The station address is set via the "ADDRESS" DIP switch. The DIP switch is binary coded. Permitted station addresses are in the range $0_D \dots 125_D$. If station address 126_D is set via the DIP switch, the address can be assigned via the Master. The Set Slave Address command (SSA) must be run for this purpose.

The station address is set as follows:

"ADDRESS" DIP switch	Meaning		Example:
Switch designation	OFF	ON	Station address PSSu: 26_D F-device: 52_D
--	Not connected		
--			
64	0	64_D	
32	0	32_D	
16	0	16_D	
8	0	8_D	
4	0	4_D	
2	0	2_D	
1	0	1_D	



INFORMATION

The station address should **only** be set when the module is switched off (no voltage applied).

The settings are **only** transferred when booting. Any changes made to the settings during operation will **not** be transferred.

5 Installation

5.1 General installation guidelines

Please also refer to the PSSuniversal Installation Manual.

The description below assumes that the mounting rail is already installed.



NOTICE

Damage due to electrostatic discharge!

Electrostatic discharge can damage components. Ensure against discharge before touching the product, e.g. by touching an earthed, conductive surface or by wearing an earthed armband.

5.2 Dimensions

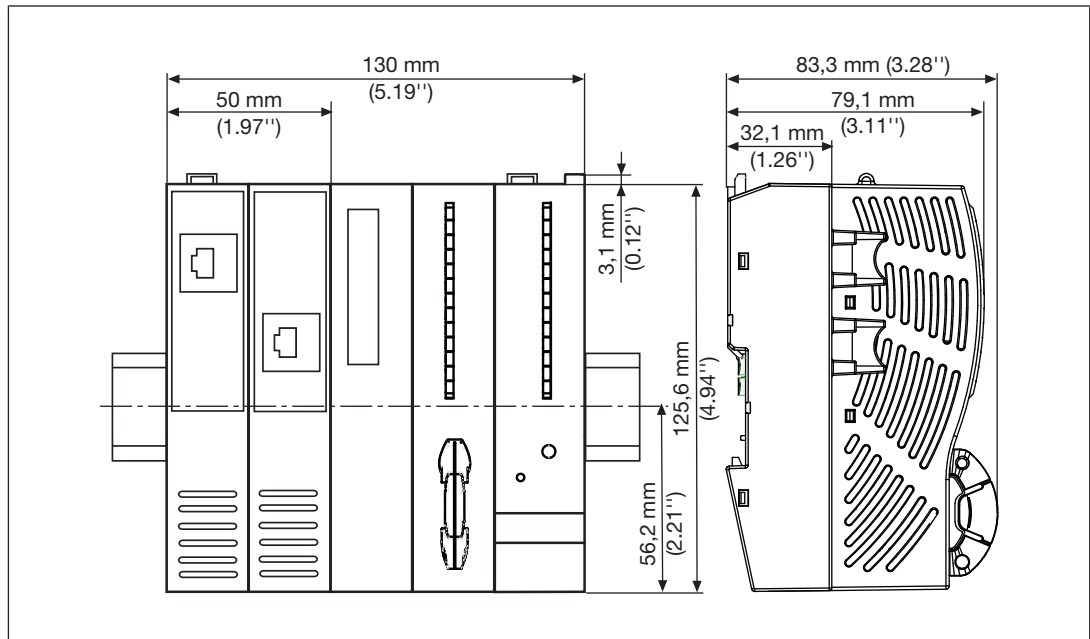

5.3 Installing the head module

Prerequisite:

- ▶ The mounting rail must be installed.

Please note:

- ▶ All contacts should be protected from contamination.

Procedure:

- ▶ Install an end bracket to the left of the head module or leave enough space for one.
- ▶ Slot the groove on the head module on to the mounting rail from below [1].
- ▶ Push the head module back as far as it will go [2].
- ▶ Make sure that the locking mechanisms [3] are pushed downwards, connecting the module firmly to the mounting rail.

Schematic representation:

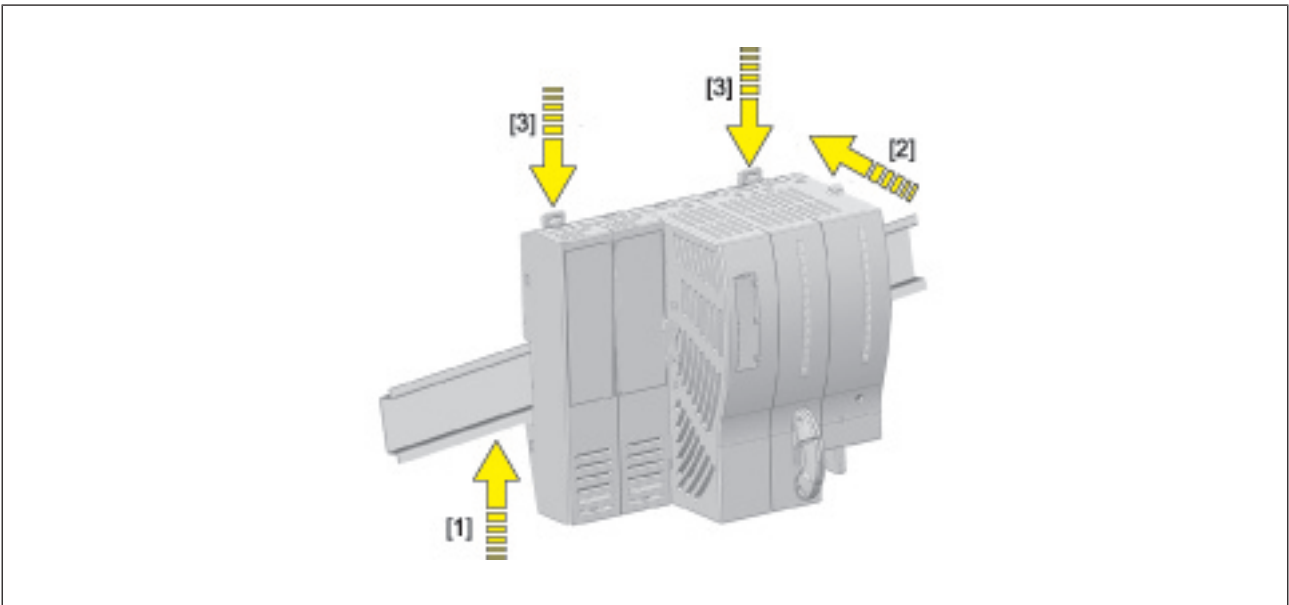

6 Interfaces

6.1 Interface configuration

6.1.1 SafetyNET p

SafetyNET p is an Ethernet interface. Further information can be found in the System Description PSS 4000.

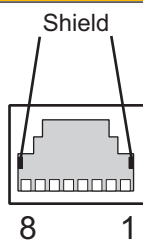
SafetyNET p	Assignment	
RJ45 female connector	1: TD+ 2: TD- 3: RD+ 4: n.c. 5: n.c. 6: RD- 7: n.c. 8: n.c.	

► n.c. = not connected

6.1.2 PROFIBUS DP

The head module can be incorporated into the PROFIBUS as slave.

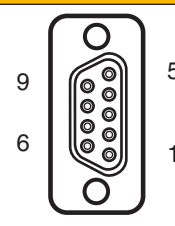
PROFIBUS DP	Layout	
Female 9-pin D-SUB connector conforms to the guidelines of the PROFIBUS User Group (PNO)	1: n.c. 2: n.c. 3: RxD/TxD-P (B-line) 4: CNTR-P (RTS) 5: DGND (GND ext.) 6: VP (+5 V ext.) 7: n.c. 8: RxD/TxD-N (A-line) 9: n.c.	

► n.c. = not connected

6.1.2.1 Connection to PROFIBUS DP

The PSSu is connected to PROFIBUS-DP via RS 485 communication. The PSSu supplies the PROFIBUS DP bus terminating resistors with voltage (+5 VDC).



INFORMATION

The two data lines are also called A and B on PROFIBUS.

Always connect the A-line ("RxD/TxD-N") to the A-lines of all the other PROFIBUS subscribers.

The B-line ("RxD/TxD-P") should only be connected to the B-lines of the other PROFIBUS subscribers.

If communication is not established, check the connections using a continuity tester.

- ▶ Connect the connector housing to the shielding on the PROFIBUS cable. The connector housing should be connected with low impedance to the mounting rail.





CAUTION!

Do not use the signals VP (+5 V ext.) and DGND (GND ext.) to supply voltage to external devices! They are exclusively used to supply the PROFIBUS DP bus terminating resistors.

7 Wiring

7.1 General wiring guidelines

Please note:

- ▶ The requirements for the supply voltages can be found in the chapter entitled [Technical details](#)  35].
- ▶ Protective separation must be ensured for the external power supplies that generate the supply voltages. Failure to do so could result in electric shock.
- ▶ The external power supplies for generating the supply voltages (periphery supply and module supply) must meet the regulations for extra low voltages with protective electrical separation (SELV, PELV). Failure to do so could result in electric shock. A device with a basic insulation that has a supply voltage of over 50 VAC or 120 VDC must not be connected in parallel to the module supply.
- ▶ The external power supplies must comply with the current applicable standard EN 62368-1 or EN 61010-2-201.
- ▶ The maximum current load for the periphery supply on the module bus is 10 A. Please refer to the derating diagram in the chapter entitled "Function Description".
- ▶ Earth the 0 V supply on the periphery supply or monitor each supply group for earth faults.
- ▶ The connection of the 0 V supply to the central earth bar or earth fault monitor must be in accordance with relevant national regulations (e.g. EN 60204-1, NFPA 79:17-7, NEC: Article 250).
- ▶ Details of the minimum range for cable cross sections on connection terminals can be found under [Technical details](#)  35].
- ▶ Use copper wiring.

7.2 Terminal configuration

Module supply	Terminal configuration		X1
4-pin female connector	24V	+24 V infeed for module supply	
	0V	0 V infeed for module supply	
Periphery supply	Terminal configuration		X2
4-pin female connector	24V:	+24 V infeed for periphery supply	
	0V	0 V infeed for periphery supply	
		Functional earth	

7.3 Connecting the module

Separate power supplies for module supply and periphery supply:

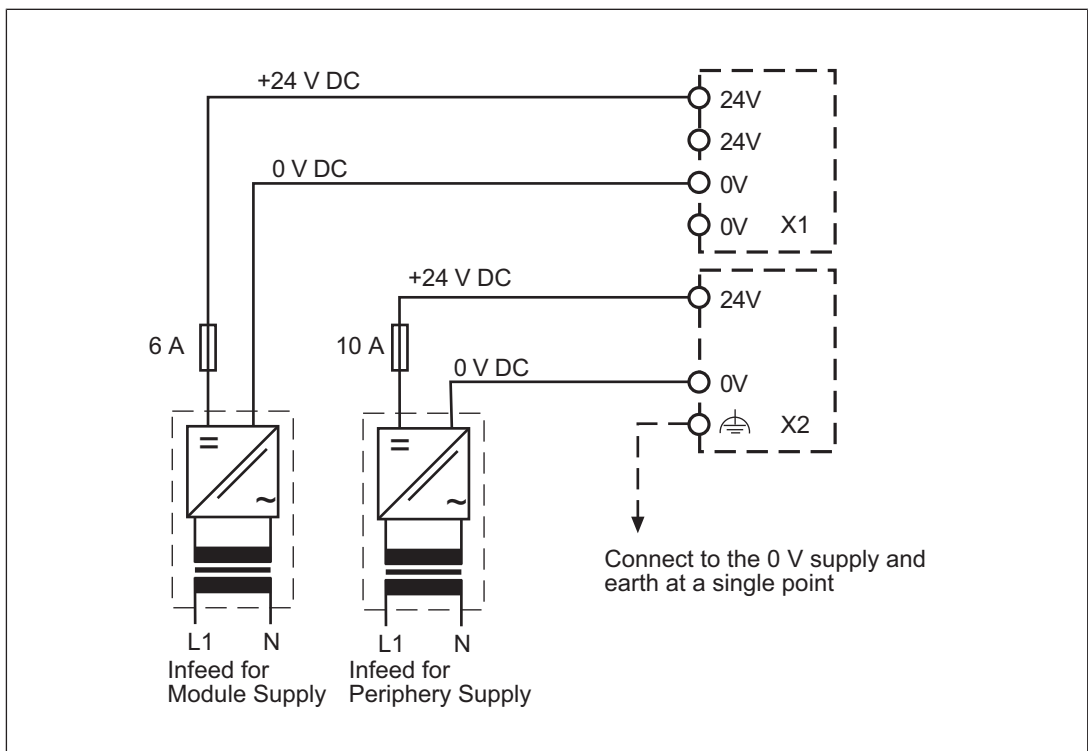

Common power supply for module supply and periphery supply:

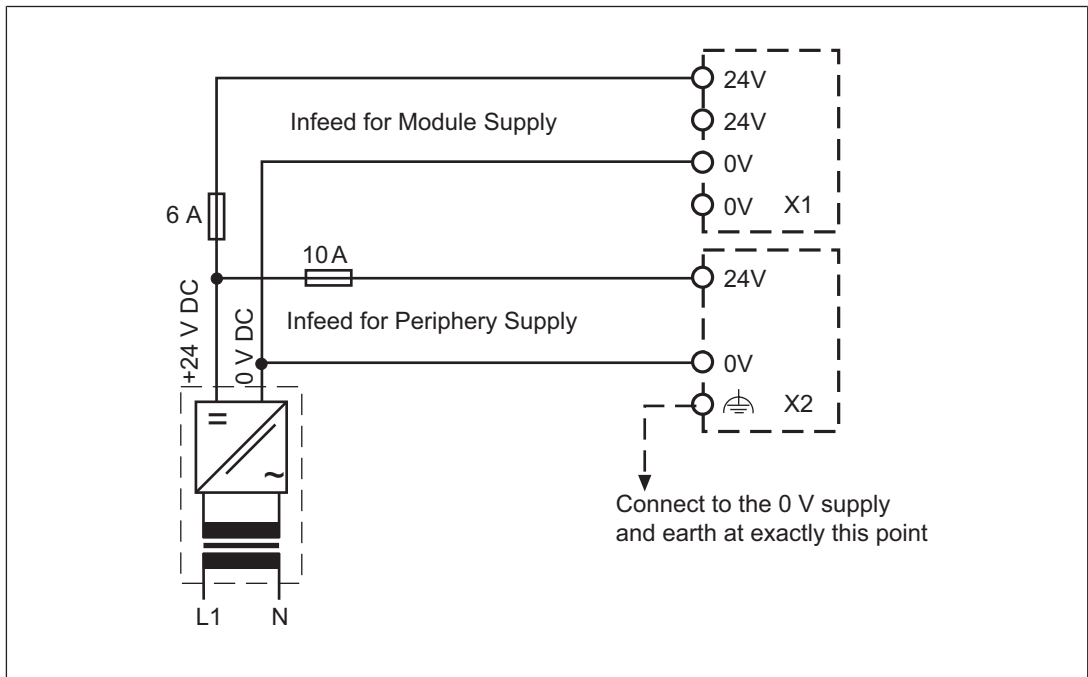

8 Operation

8.1 Messages

The PSSu system provides many options for diagnostics, fault detection and communication with other control systems.

Diagnostics for the PSSu system can be run via the

- ▶ LEDs on the head module,
- ▶ Diagnostic table and diagnostic log.

All errors and faults detected by the electronic or compact modules in a PSSu system are signalled to the head module and entered in the diagnostic table and diagnostic log. You can read the head module's diagnostic table and diagnostic log, e.g. using the PAS4000 or the combination of OPC Server and PSS 4000 Diag Control.



8.2 Display elements

The head module contains a number of status LEDs, which provide information on the status of various system sections.

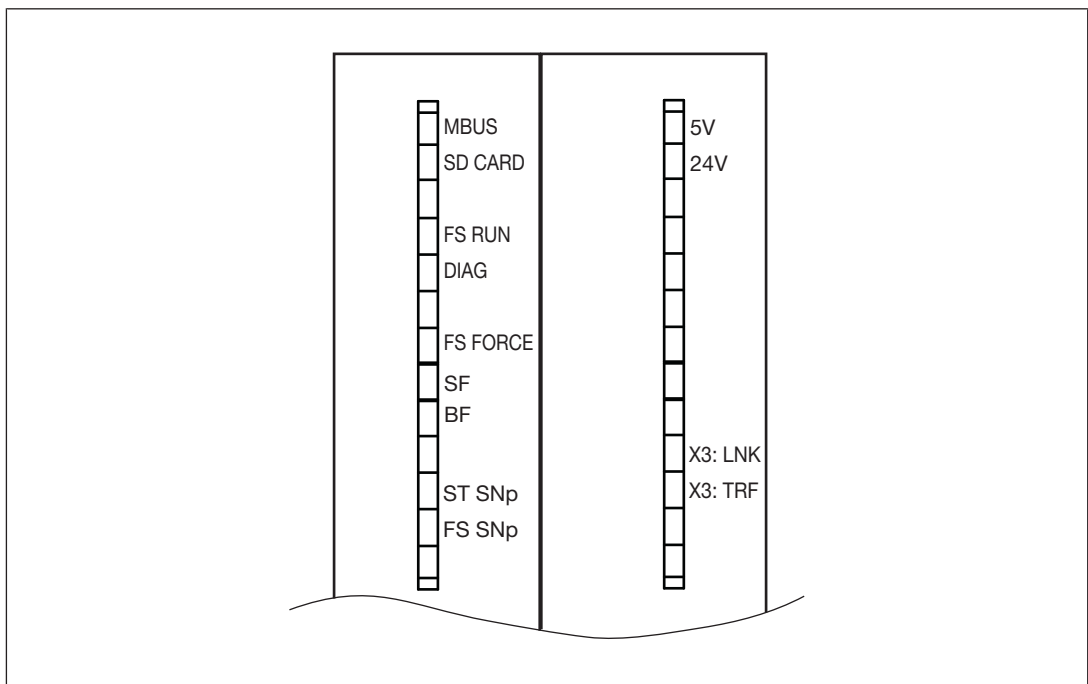
LEDs on the PSSu H m F DP SN SD:







Legend

-  LED on
-  LED flashes
-  LED off







8.2.1 MBUS

The "MBUS" LED indicates the status of the FS and ST module bus.

Colour	Status	Meaning
- - -		No modules are configured and no modules are available.
Green		FS and ST module bus are operating without error
Red		Operating state "Safe state of all FS outputs on the PSSu system" or Unable to locate at least one module (e.g. a module has been removed during operation, set/actual hardware registry does not match)
		Operating state "FS module bus in STOP state with error: major FS error"





8.2.2 SD CARD

The LED indicates the status of the SD card and is used for device identification.

Colour	Status	Meaning
- - -		Supply voltage for module supply is missing
Red		<ul style="list-style-type: none"> ▶ SD card is missing or ▶ SD card not recognised or ▶ SD card defective or ▶ Recovery mode: For some reason, the file system of the SD card could not reconstruct a consistent state.
		<ul style="list-style-type: none"> ▶ "Bind device projects to devices" function: <ul style="list-style-type: none"> – The device does not have the device key that matches the device project. or – The device project does not have the project key that matches the device. and/or ▶ "Bind device projects to SD cards" function: <ul style="list-style-type: none"> The device project is bound to an SD card, but this SD card is not inserted in the device.
Green		Naming data and device project on the device and SD card match
		<ul style="list-style-type: none"> ▶ Product type on the SD card does not match the product type of the device/head module or ▶ No device project on the SD card or ▶ Recovery mode: The file system of the SD card is in a consistent state and the SD card can be removed.
Green-red		Naming data and device project on the device and SD card do not match
Orange		<ul style="list-style-type: none"> Device identification activated by user ▶ Identification as PSS 4000 device in SafetyNET p (PAS4000) or ▶ Identification as PROFINET IO Device in PROFINET (engineering tool for PROFINET)

8.2.3 FS RUN







The "FS RUN" LED indicates the status of the FS resource.

Colour	Status	Meaning
- - -		None of the tasks on the FS resource are started or no tasks are configured.
Green		Operating state "FS resource in RUN state without error": The FS resource tasks are running without error. The project is licensed.
		Operating state "FS resource in RUN state with error": - Task in TERMINATED state or - Task in STOP state At least one FS resource task is not running. The project is licensed.
Orange		Operating state "FS resource in RUN state without error": The FS resource tasks are running without error. The project is unlicensed.
		Operating state "FS resource in RUN state with error": - Task in TERMINATED state or - Task in STOP state At least one FS resource task is not running. The project is unlicensed.

► Only one task is present on the FS resource.



8.2.4 DIAG

The "DIAG" LED indicates whether there is a fault in a system section. Precise evaluation can be made via the diagnostic list.

Colour	Status	Meaning
- - -		No system section is started, module supply is missing.
Green		No message of "Error" or "Warning" severity is present for the device.
		Device diagnostic list and device diagnostic log are being prepared
Red		A message of "Error" severity is present for at least one system section (see diagnostic table).
		<ul style="list-style-type: none"> ▶ A major FS error is present for at least one FS system section (see diagnostic list). or <ul style="list-style-type: none"> ▶ The boot process was stopped because an internal error occurred. Diagnostics are not available. The reset pushbutton has no function.
Orange		A message of at least "Warning" severity is present for the device (see diagnostic list).
Red - green		Start of "deliberate operator action" (function of reset button)











8.2.5 FS FORCE

The "FS FORCE" LED indicates the status of forcing and online changes on the FS resource.

Colour	Status	Meaning
- - -		On the FS resource, forcing is inactive and there is no on-line change active
Yellow		On the FS resource, forcing is active and/or there is at least one online change active





8.2.6 SF, BF

The LEDs "SF" and "BF" indicate errors in the bus connection or errors by a subscriber in the bus.

Colour SF	Colour BF	Status SF	Status BF	Meaning
---	---			Supply voltage is missing
---	Red			No connection to the bus subscribers
---	Red			Configuration faulty
Red	---			Error in the head module
---	Green			Data transmission error-free





8.2.7 ST SNp

The "ST SNp" LED indicates the status of the non-safety-related system section ST SafetyNET p.

Colour	Status	Meaning
---		System section ST SafetyNET p has not been started
Green		Operating state "ST SafetyNET p in RUN state without error"
		Operating state "ST SafetyNET p in RUN state with minor error"
Red		Operating state "ST SafetyNET p in STOP state with error: Major FS+ST error"
		



8.2.8 FS SNp

The "FS SNp" LED indicates the status of the safety-related system section FS SafetyNET p.



Colour	Status	Meaning
- - -		System section FS SafetyNET p has not been started
Green		Operating state "FS SafetyNET p in RUN state without error"
		Operating state "FS SafetyNET p in RUN state with minor error"
Red		Operating state "FS SafetyNET p in STOP state with error: Major FS error"
		Operating state "FS SafetyNET p in STOP state with error: Major FS+ST error"

8.2.9 5V, 24V

The "5 V" LED indicates the status of the module supply.

Colour	Status	Meaning
- - -		No supply voltage for module supply or supply voltage is faulty
Green		Module supply is available



The "24 V" LED indicates the status of the periphery supply.

Colour	Status	Meaning
- - -		No supply voltage for periphery supply or supply voltage is faulty
Green		Periphery supply is available



8.2.10 X3: LNK, X3: TRF

These status LEDs are the display elements for the Ethernet/SafetyNET p interfaces. The interface is assigned two LEDs at the head module. Various operating and fault statuses on the Ethernet/SafetyNET p interface are displayed via the LEDs.

X3: LNK

Colour	Status	Meaning
---		No network connection
Green		Network connection is error-free

X3: TRF

Colour	Status	Meaning
---		No data traffic
Yellow		Data traffic is error-free

9 Technical details

General	
Certifications	CE, EAC, KOSHA, TÜV, UKCA, cULus Listed
Application range	Standard/failsafe
System sections	
ST resource	No
FS resource	Yes
ST module bus PSSu	Yes
FS module bus PSSu	Yes
ST SNp interface	Yes
FS SNp interface	Yes
PROFIBUS-DP Slave	Yes
PROFINET IO DEVICE	No
IP connections	Yes
Diagnostic Server	No
OPC Server	No
Programming	
IEC 61131 programming	No
Multi programming	Yes
Non-volatile variables	No
Electrical data	
Supply voltage	
for	Module supply
Voltage	24 V
Kind	DC
Voltage tolerance	-30 %/+25 %
Max. continuous current that the external power supply must provide	1 A
Output of external power supply (DC)	16,1 W
Supply voltage	
for	Periphery supply
Voltage	24 V
Kind	DC
Voltage tolerance	-30 %/+25 %
Max. continuous current that the external power supply must provide	10 A
Potential isolation between module supply and periphery supply	2500 V
Potential isolation between module supply and PROFIBUS-DP	700 V

Electrical data

Internal supply voltage (module supply)	
Output voltage	int. system
Voltage	5 V
Kind	DC
Voltage tolerance	-2 %/+3 %
Potential isolation	2500 V
Current load capacity	2 A
Buffer in the case of supply interruptions in accordance with	EN 61131-2, EN 61496-1
Short circuit-proof	Yes

CPU

Real-time clock for time and date functions	
Resolution	1 s
Deviation	+/- 10s/day
Buffer time	10 days
Max. number of FS tasks	1
Min. cycle time of FS tasks	10 ms
Working memory (RAM)	128MB
Memory for the user program per resource	2 MB

Removable data medium

Type	SD card
------	----------------

SafetyNET p interface

Quantity	1
IP address (automatically off)	169.254.X.Y
Connection	RJ45
Transmission rates	100 MBit/s
Set via	Automatic
Max. number of ST-Tx and ST-Rx connections	5
Max. number of FS-Tx and FS-Rx connections	5
Cycle time (t _{SNp} RTFN)	10 ... 60 000 ms

PROFIBUS-DP interface

Quantity	1
Device type	Slave
Station address	0 ... 126d
Station address selectable via	DIP-Schalter
Maximum data length of PROFIBUS interface	
Input	244 Byte
Output	244 Byte
Diagnostics	2 Byte
Transmission rates	1,5 MBit/s, 12 MBit/s, 185,5 kBit/s, 19,2 kBit/s, 3 MBit/s, 45,45 kBit/s, 500 kBit/s, 6 MBit/s, 9,6 kBit/s, 93,75 kBit/s
Transmission rate selectable via	Automatic
Connection	9-pin D-Sub female connector
Protocol	DPV0

PROFIBUS-DP interface	
Operating modes	AutoBaud, Freeze Mode, Set Slave Address, Sync Mode
Certification	PNO
Description file	Pilz0CB0.gsd
Vendor ID	0CB0h
Cycle time (t_ExtCo)	2 ... 300 000 ms
Ethernet interface	
Quantity	1
IP address (automatically off)	169.254.X.Y
Connection type	RJ45
Transmission rate	100 MBit/s
Modbus/TCP	
Cycle time (t_ExtCo)	2 ... 2 000 000 ms
Raw UDP	
Cycle time (t_ExtCo)	2 ... 2 000 000 ms
Environmental data	
Climatic suitability	EN 60068-2-1, EN 60068-2-14, EN 60068-2-2, EN 60068-2-30, EN 60068-2-78
Ambient temperature	
Temperature range	0 - 60 °C
Storage temperature	
Temperature range	-40 - 70 °C
Climatic suitability	
in accordance with the standard	EN 60068-2-78
Humidity	93 % r. h. at 40 °C
Condensation during operation	Not permitted
Max. operating height above SL	2000 m
EMC	EN 61000-6-2, EN 61000-6-4, EN 61131-2 (Zone B)
Vibration	
in accordance with the standard	EN 60068-2-6
Frequency	8,4 - 150 Hz
Acceleration	10 m/s²
Shock stress	
in accordance with the standard	EN 60068-2-27
Number of shocks	6
Acceleration	150 m/s²
Duration	11 ms
Airgap creepage	
in accordance with the standard	EN 61131-2
Overvoltage category	II
Pollution degree	2
Protection type	
Housing	IP20
Mounting area (e.g. control cabinet)	IP54

Potential isolation

Rated surge voltage in operating heights up to max.
2000 m **2500 V**

Mechanical data

Material	PC
Bottom	PC
Connection type	Spring-loaded terminal, screw terminal
Mounting type	plug-in
Conductor cross section with screw terminals	
1 core flexible	0,25 - 2,5 mm², 24 - 12 AWG
2 core with the same cross section, flexible with crimp connectors, no plastic sleeve	0,25 - 1 mm², 24 - 16 AWG
2 core with the same cross section, flexible without crimp connectors or with TWIN crimp connectors	0,2 - 1,5 mm², 24 - 16 AWG
Torque setting with screw terminals	0,5 Nm
Conductor cross section with spring-loaded terminals:	
Flexible with/without crimp connector	0,2 - 2,5 mm², 24 - 12 AWG
Stripping length with spring-loaded terminals	9 mm
Dimensions	
Height	125,6 mm
Width	130 mm
Depth	83,7 mm
Weight	375 g

Where standards are undated, the 2022-01 latest editions shall apply.

9.1 Safety characteristic data



NOTICE

You must comply with the safety characteristic data in order to achieve the required safety level for your plant/machine.

Operating mode	EN ISO 13849-1: 2015 PL	EN ISO 13849-1: 2015 Category	EN IEC 62061 SIL CL/ maximum SIL	EN IEC 62061 PFH _D [1/h]	EN/IEC 61511 SIL	EN/IEC 61511 PFD	EN ISO 13849-1: 2015 T _M [year]
–	PL e	Cat. 4	SIL CL 3	4,14E-09	SIL 3	3,51E-05	20

Explanatory notes for the safety-related characteristic data:

- ▶ Safety characteristic data in accordance with EN IEC 62061 and EN/IEC 61511 was calculated based on EN/IEC 61508.
- ▶ T_M is the maximum mission time in accordance with EN ISO 13849-1. The value also applies as the retest interval in accordance with EN/IEC 61508-6 and EN/IEC 61511 and as the proof test interval and mission time in accordance with EN IEC 62061.

All the units used within a safety function must be considered when calculating the safety characteristic data.



INFORMATION

A safety function's SIL/PL values are **not** identical to the SIL/PL values of the units that are used and may be different. We recommend that you use the PASCAL software tool to calculate the safety function's SIL/PL values.

10 Order reference

10.1 Product

Product type	Features	Order no.
PSSu H m F DP SN SD	Head module with SafetyNET p and PROFIBUS-DP, base type	312065

10.2 Accessories

Terminals

Product type	Features	Order no.
PSSu A Con 1/4 S	2 x screw terminals	313110
PSSu A Con 2/8 C	2 x spring-loaded terminals	313111

11 **EC declaration of conformity**

This product/these products meet the requirements of the directive 2006/42/EC for machinery of the European Parliament and of the Council. The complete EC Declaration of Conformity is available on the Internet at www.pilz.com/downloads.

Authorised representative: Norbert Fröhlich, Pilz GmbH & Co. KG, Felix-Wankel-Str. 2, 73760 Ostfildern, Germany

12 UKCA-Declaration of Conformity

This product(s) complies with following UK legislation: Supply of Machinery (Safety) Regulation 2008.

The complete UKCA Declaration of Conformity is available on the Internet at www.pilz.com/downloads.

Representative: Pilz Automation Technology, Pilz House, Little Colliers Field, Corby, Northamptonshire, NN18 8TJ United Kingdom, eMail: mail@pilz.co.uk

► Support

Technical support is available from Pilz round the clock.

Americas

Brazil

+55 11 97569-2804

Canada

+1 888 315 7459

Mexico

+52 55 5572 1300

USA (toll-free)

+1 877-PILZUSA (745-9872)

Asia

China

+86 21 60880878-216

Japan

+81 45 471-2281

South Korea

+82 31 778 3300

Australia and Oceania

Australia

+61 3 95600621

New Zealand

+64 9 6345350

Europe

Austria

+43 1 7986263-0

Belgium, Luxembourg

+32 9 3217570

France

+33 3 88104003

Germany

+49 711 3409-444

Ireland

+353 21 4804983

Italy, Malta

+39 0362 1826711

Scandinavia

+45 74436332

Spain

+34 938497433

Switzerland

+41 62 88979-32

The Netherlands

+31 347 320477

Turkey

+90 216 5775552

United Kingdom

+44 1536 462203

You can reach our international hotline on:

+49 711 3409-222

support@pilz.com

Pilz develops environmentally-friendly products using ecological materials and energy-saving technologies. Offices and production facilities are ecologically designed, environmentally-aware and energy-saving. So Pilz offers sustainability, plus the security of using energy-efficient products and environmentally-friendly solutions.



We are represented internationally. Please refer to our homepage www.pilz.com for further details or contact our headquarters.

Headquarters: Pilz GmbH & Co. KG, Felix-Wankel-Straße 2, 73760 Ostfildern, Germany
Telephone: +49 711 3409-0, Telefax: +49 711 3409-133, E-Mail: info@pilz.com, Internet: www.pilz.com

PILZ
THE SPIRIT OF SAFETY

1002324-EN-08, 2023-05 Printed in Germany
© Pilz GmbH & Co. KG, 2019

CECE®, CHRE®, CMSE®, InduraNET p®, Leansafe®, Master of Safety®, Master of Security®, PAS4000®, PAScall®, PASconfig®, Pilz®, PTT®, PLID®, PMCPirimo®, PMCPiritego®, PMCTendo®, PMD®, PMJ®, PNOZ®, PRBM®, PRCM®, PRIMO®, PRM®, PRTM®, PSEN®, PSS®, PVS®, SafetyBUS p®, SafetyEYE®, THE SPIRIT OF SAFETY® are registered and protected trademarks of Pilz GmbH & Co. KG in some countries. We would point out that product features may vary from the details stated in this document, depending on the status at the time of publication and the scope of the equipment. We accept no responsibility for the validity, accuracy and entirety of the text and graphics presented in this information. Please contact our Technical Support if you have any questions.