

PSSu H SB(-T)



Decentralised system PSSuniversal I/O

This document is a translation of the original document.

All rights to this documentation are reserved by Pilz GmbH & Co. KG. Copies may be made for internal purposes.

Suggestions and comments for improving this documentation will be gratefully received.

Pilz[®], PIT[®], PMI[®], PNOZ[®], Primo[®], PSEN[®], PSS[®], PVIS[®], SafetyBUS p[®], SafetyEYE[®], SafetyNET p[®], the spirit of safety[®] are registered and protected trademarks of Pilz GmbH & Co. KG in some countries.



SD means Secure Digital.

Contents		Page
Chapter 1 Introduction		
1.1	Validity of documentation	1-1
1.1.1	Retaining the documentation	1-1
1.2	Overview of documentation	1-2
1.3	Definition of symbols	1-3
Chapter 2 Overview		
2.1	Module features	2-1
2.2	Front view	2-2
Chapter 3 Safety		
3.1	Intended use	3-1
3.2	Safety regulations	3-3
3.2.1	Use of qualified personnel	3-3
3.2.2	Warranty and liability	3-3
3.2.3	Disposal	3-3
Chapter 4 Function description		
4.1	Module features	4-1
4.1.1	Integrated protection mechanisms	4-1
4.1.2	Supply voltage	4-1
4.2	SafetyBUS p	4-2
4.2.1	Connection to SafetyBUS p	4-2
4.2.2	Selector switch for setting the device address	4-2
4.3	USB port	4-3
Chapter 5 Installation		
5.1	General installation guidelines	5-1
5.1.1	Dimensions	5-1
5.2	Installing the head module	5-2
Chapter 6 Interfaces		
6.1	Interface assignment	6-1
6.1.1	Connection to SafetyBUS p	6-1
6.1.2	Connection via USB	6-1
Chapter 7 Operation		
7.1	Messages	7-1
7.2	Display elements	7-3
7.2.1	Display elements for system diagnostics	7-3
7.2.2	Display elements for SafetyBUS p diagnostics	7-5

Chapter 8 Technical details		
------------------------------------	--	--

8.1	Technical details	8-1
-----	-------------------	-----

8.2	Order reference	8-3
-----	-----------------	-----

1.1 Validity of documentation

This documentation is valid for the product **PSSu H SB** and **PSSu H SB-T**. It is valid until new documentation is published.

Please also refer to the following documents:

- ▶ SafetyBUS p System Description
- ▶ SafetyBUS p Installation Manual
- ▶ PSSuniversal System Description
- ▶ PSSuniversal Installation Manual

This operating manual explains the function and operation, describes the installation and provides guidelines on how to connect the product .

1.1.1 Retaining the documentation

This documentation is intended for instruction and should be retained for future reference.

1.2 Overview of documentation

1 Introduction

The introduction is designed to familiarise you with the contents, structure and specific order of this manual.

2 Overview

This chapter provides information on the module's most important features.

3 Safety

This chapter must be read as it contains important information on safety and intended use.

4 Function Description

This chapter describes the module's individual components.

5 Installation

This chapter explains how to install the module.

6 Interfaces

This chapter describes the module's interfaces.

7 Operation

This chapter explains the display elements and advises on what to do if a fault occurs.

8 Technical Details

This chapter contains the product's technical details and order reference.

1.3 Definition of symbols

Information that is particularly important is identified as follows:



DANGER!

This warning must be heeded! It warns of a hazardous situation that poses an immediate threat of serious injury and death and indicates preventive measures that can be taken.



WARNING!

This warning must be heeded! It warns of a hazardous situation that could lead to serious injury and death and indicates preventive measures that can be taken.



CAUTION!

This refers to a hazard that can lead to a less serious or minor injury plus material damage, and also provides information on preventive measures that can be taken.



NOTICE

This describes a situation in which the unit(s) could be damaged and also provides information on preventive measures that can be taken. It also highlights areas within the text that are of particular importance.



INFORMATION

This gives advice on applications and provides information on special features.

1 Introduction

2.1 Module features

The product has the following features:

- ▶ **SafetyBUS p** interface for
 - Failsafe inputs/outputs
- ▶ USB port for connection to a PC for
 - Commissioning
 - Service
- ▶ LEDs for:
 - System status
 - **SafetyBUS p** status
 - USB status
- ▶ Electronic modules that can be used for input/output:
 - All failsafe modules (PSSu E F...)
- ▶ Coated version of the module:
PSSu H SB-T: for increased environmental requirements

2.2 Front view

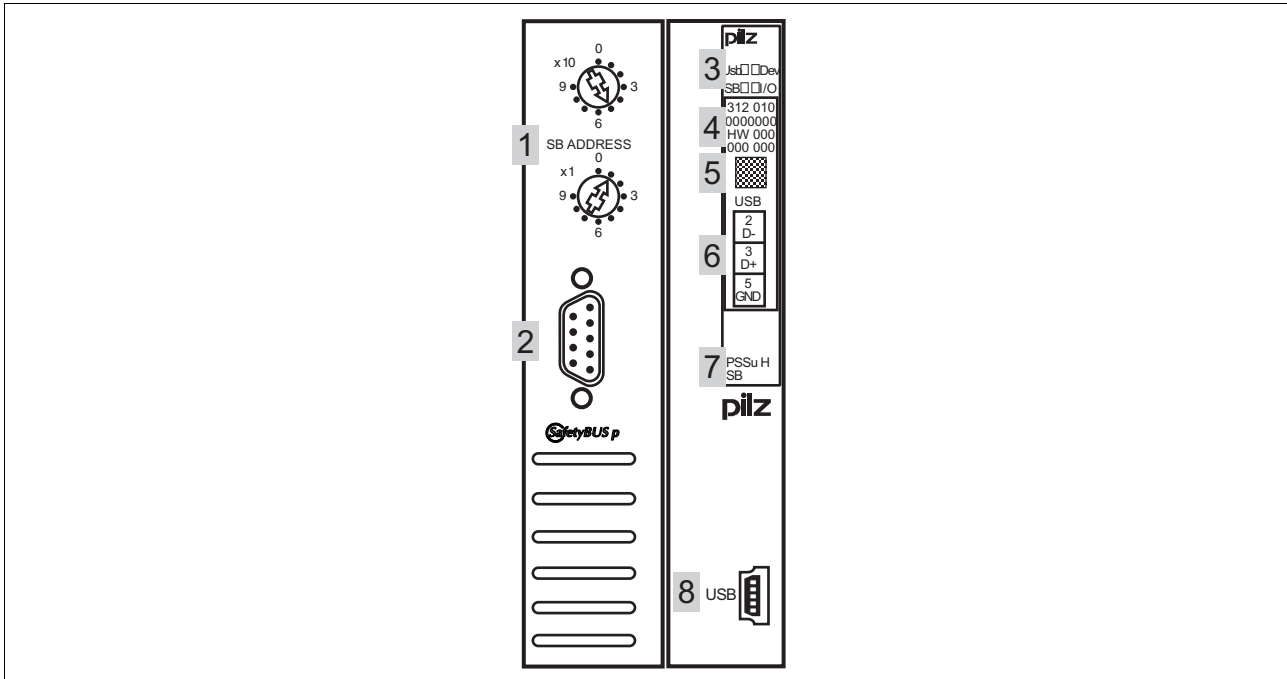

Key:

- ▶ 1: Two selector switches for setting the device address
- ▶ 2: SafetyBUS p interface
- ▶ 3: LEDs for system diagnostics and SafetyBUS p diagnostics
- ▶ 4: Labelling strip with:
 - Order number
 - Serial number
 - Hardware version number
 - Firmware version number on delivery
- ▶ 5: Field for 2D code
- ▶ 6: Labelling strip with interface configuration of the USB port
- ▶ 7: Description of head module
- ▶ 8: USB port (Mini-B)

3.1 Intended use

The module is designed for use in safety-related applications with **SafetyBUS p**.

The module **PSSu H SB-T** is suitable for use where there are increased environmental requirements (see Technical Details).

The module meets the requirements of EN IEC 61508 up to **SIL3** and EN 954-1 up to Category **4**.

Intended use includes making the electrical installation EMC-compliant. Please refer to the guidelines stated in the "PSSuniversal Installation Manual". The module is designed for use in an industrial environment. It is not suitable for use in a domestic environment, as this can lead to interference.

The following is deemed improper use in particular:

- ▶ Any component, technical or electrical modification to the module
- ▶ Use of the module outside the areas described in this manual
- ▶ Use of the module outside the technical details (see chapter entitled "Technical Details")



INFORMATION

The module is supported by the PSSuniversal Configurator and PSSuniversal Assistant from Version 1.4.0. We recommend that you always use the latest version (download from www.pilz.de). The module is supported by programmable safety systems with SafetyBUS p interface, from FS operating system version 50/18.

Programmable safety systems with an older FS operating system version will have a restricted function range.

3.1 Intended use

The head module may be used in conjunction with the following electronic modules:

Module type	Module name
Voltage supply	PSSu E F PS(-T)
	PSSu E F PS1(-T)
	PSSu E F PS-P(-T)
	PSSu E F BSW(-T)
Digital input/output modules	PSSu E F 4DI(-T)
	PSSu E F 4DO 0.5(-T)
	PSSu E F 2DO 2(-T)
	PSSu E F 2DOR 8(-T)
	PSSu E F DI OZ 2(-T)
Voltage distribution	PSSu E PD(-T)
	PSSu E PD1(-T)

The module's firmware can be updated to a later version using the Firmware Manager on the PSSUniversal Assistant. For the reason, the module's actual firmware version may not always match the firmware version printed on the front of the unit. Updating the firmware can also expand the module's functionality.



INFORMATION

The module's actual firmware version can only be established using the Firmware Manager on the PSSUniversal Assistant.

3.2 Safety regulations

3.2.1 Use of qualified personnel

The products may only be assembled, installed, programmed, commissioned, operated, maintained and decommissioned by competent persons.

A competent person is someone who, because of their training, experience and current professional activity, has the specialist knowledge required to test, assess and operate the work equipment, devices, systems, plant and machinery in accordance with the general standards and guidelines for safety technology.

It is the company's responsibility only to employ personnel who:

- ▶ Are familiar with the basic regulations concerning health and safety / accident prevention
- ▶ Have read and understood the safety guidelines given in this description
- ▶ Have a good knowledge of the generic and specialist standards applicable to the specific application.

3.2.2 Warranty and liability

All claims to warranty and liability will be rendered invalid if:

- ▶ The product was used contrary to the purpose for which it is intended
- ▶ Damage can be attributed to not having followed the guidelines in the manual
- ▶ Operating personnel are not suitably qualified
- ▶ Any type of modification has been made (e.g. exchanging components on the PCB boards, soldering work etc.).

3.2.3 Disposal

- ▶ In safety-related applications, please comply with the mission time t_M in the safety-related characteristic data.
- ▶ When decommissioning, please comply with local regulations regarding the disposal of electronic devices (e.g. Electrical and Electronic Equipment Act).

4 Function description

4.1 Module features

4.1.1 Integrated protection mechanisms

The module has the following protection mechanisms:

- ▶ Multi-channel diverse processor section
- ▶ Cyclical self tests
- ▶ Potentially isolated **SafetyBUS p** interface
- ▶ When the PSSu E F PS1(-T) is used to supply the system, the module supply is buffered for 20 ms if the supply voltage is interrupted.

4.1.2 Supply voltage

Module supply

- ▶ The module supply provides the module with voltage.

4.2 SafetyBUS p

4.2.1 Connection to SafetyBUS p

A PSSu with SafetyBUS p interface is regarded as a bus subscriber in a SafetyBUS p network.

The “SafetyBUS p Installation Manual” and the “SafetyBUS p System Description” apply for subscribers in a SafetyBUS p network.

Detailed descriptions for commissioning are available in the online help for the PSS WIN-PRO system software. Step-by-step instructions can be found in the manual: "Getting Started: Full version of PSS WIN-PRO".

4.2.2 Selector switch for setting the device address

The device address of a PSSu is set via the two rotary switches “x 10” and “x 1”.

Permitted device addresses are in the range $32_D \dots 95_D$. The same applies if the PSSu system is configured for SafetyBUS p 1 in the SafetyBUS p Configurator on the PSS WIN-PRO system software. The offset of 100_D for device addresses on SafetyBUS p 1 is calculated automatically from the bus configuration.

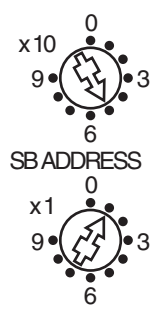
Rotary switch “SB ADDRESS”: Switch designation	Key	Example: Device address 51_D
x 10	Set the tens	
x 1	Set the units	

4.3 USB port

The following functions are available via the USB port:

- ▶ Show actual hardware
- ▶ Comparison of actual/registered hardware
- ▶ Display and update firmware versions
- ▶ Setting the parameters for the ST section

Parameters for the module's ST section can either be set via the fieldbus interface or via the USB port. Parameter setting via the USB port has priority over parameter setting via the fieldbus interface. Once parameters for the the head module have been set via the USB port, the ability to set parameters for the module via the fieldbus interface is disabled. The disable can be lifted in the PSSuniversal Assistant.

Procedure for connecting the head module via the USB port:

- ▶ Connect PC to head module via USB cable.
- ▶ Install USB driver.
- ▶ View the actual hardware registry in the PSSuniversal Assistant and call up other functions.

This way it is possible to copy and edit an existing configuration in the PSSuniversal Assistant.



INFORMATION

The USB driver can be found on the PSSuniversal Assistant CD-ROM, in the subdirectory \bin\PILZ_USB_DRIVER

4 Function description

5.1 General installation guidelines

Please also refer to the PSSuniversal Installation Manual.

The description below assumes that the mounting rail is already installed.



CAUTION!

Damage due to electrostatic discharge!

Electrostatic discharge can damage components. Ensure against discharge before touching the product, e.g. by touching an earthed, conductive surface or by wearing an earthed arm-band.

5.1.1 Dimensions

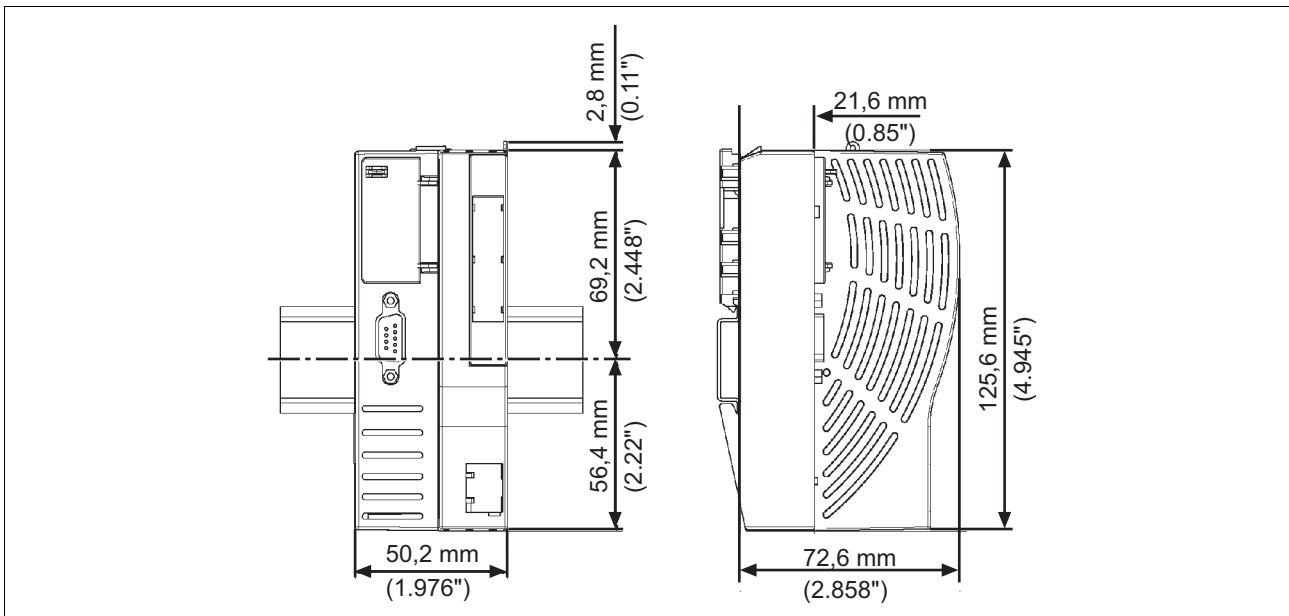

5.2 Installing the head module

Prerequisite:

- ▶ The mounting rail must be installed.



Procedure:

- ▶ Install an end bracket to the left of the head module or leave enough space for one.
- ▶ Slot the groove on the head module on to the mounting rail from below [1].
- ▶ Push the head module back [2] until you hear it lock into position.

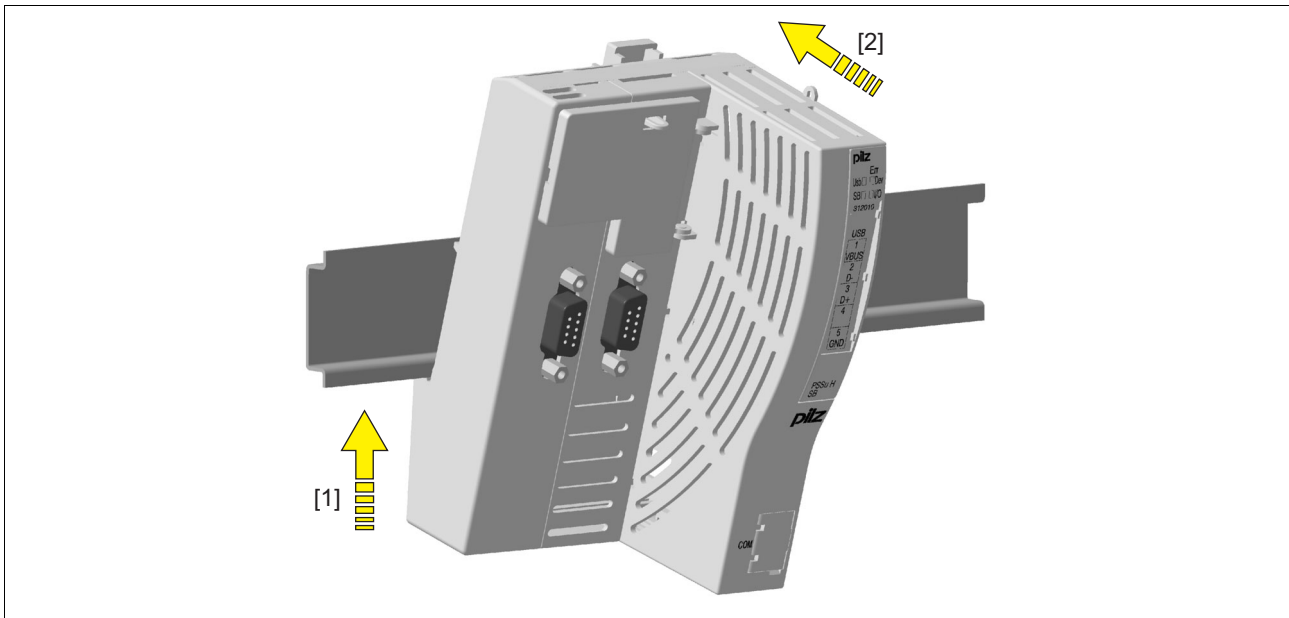
Schematic representation:

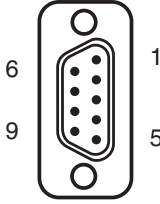

6.1 Interface assignment

SafetyBUS p	Layout	
Male 9-pin D-SUB connector	1: n.c. 2: CAN_L (brown) 3: CAN_GND (white) 4: n.c. 5: CAN_SHLD 6: n.c. 7: CAN_H (green) 8: Supply voltage for fibre-optic cou- plers from Pilz 9: n.c.	
USB	Layout	
Mini-B USB connector	1: n.c. 2: D- USB Data - 3: D+ USB Data + 4: n.c. 5: GND Ground	

► n.c. = not connected

6.1.1 Connection to SafetyBUS p

Please refer to the SafetyBUS p Installation Manual.

6.1.2 Connection via USB

Please note the requirements of the USB standard for USB 2.0 and for Mini-B USB ports.

The maximum cable runs for USB connection cable are 5 m.

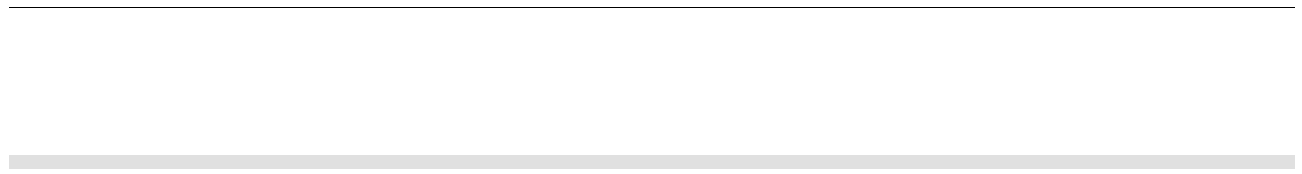

7.1 Messages

All errors and faults detected by the electronic modules on a PSSu are signalled to the head module and entered in the head module's error stack. You can read the head module's error stack using the PSS WIN-PRO system software (SafetyBUS p, Domain 0).

Module error	Explanation	Remedy
Start-up error	Error as the PSSu system starts up	Change faulty module.
Configuration error	Incorrect module type configured.	The configured hardware registry does not match the actual hardware registry.
FS communication error	Error during FS communication	Change faulty module.
Bus termination error	There is no terminating plate or there is a bad contact with the module bus.	Install a terminating plate with integrated end bracket or insert the base modules together correctly.
Temperature error: Too warm ⁽¹⁾	Ambient temperature too high: Error stack entry	Ensure there is sufficient ventilation in the control cabinet or prevent overload.
Temperature error: Too hot ⁽¹⁾	Ambient temperature too high: Reset the module and stop the affected I/O-Groups (SafetyBUS p)	Ensure there is sufficient ventilation in the control cabinet or prevent overload.
Output error	Error during cyclical output test for short circuit. Possible causes: Short circuit, or output defective.	Rectify the short circuit or change the faulty module.
Test pulse error	Possible causes: Short circuit between a test pulse and a supply voltage, or a defective module.	Rectify the short circuit or change the faulty module.
Relay control error	Error during cyclical monitoring test of the relay coils	Change faulty relay module.
Relay error	A relay position is faulty. Possible cause: Defective relay contact	Change faulty relay module.
Block switching output error	Error during cyclical monitoring test of the relay contacts. Possible external cause: Voltages being fed back to the relay contacts	Check the supply voltage and the wiring.
Error in the feedback loop	FS input detects an error in the feedback loop or FS input is defective.	Check FS input, check the configuration of the feedback loop, check the signals, or check the wiring and contacts.
Error in the local enable principle	FS output has reacted incorrectly or unexpectedly	Check the configuration of the FS output or check the fieldbus signals in the FS and ST section.
Input error	Error during the cyclical input test. Possible cause: Input defective.	Change faulty module.
Overvoltage error	A system voltage or infeed is too high.	Stabilise the supply or change the faulty supply voltage module.

7.1 Messages

Module error	Explanation	Remedy
Undervoltage error	A system voltage or infeed is too low.	Stabilise the supply or change the faulty supply voltage module.
Error in the overvoltage protection diodes	Overvoltage protection diodes are defective.	Change faulty supply voltage module.

(¹) There are two levels of overtemperature.

▶ Too warm:

If a module's temperature exceeds a threshold value, the module sends a warning to the head module. If the temperature drops back below the threshold value, the module sends an all-clear.

▶ Too hot:

If a module's temperature exceeds a further threshold value, the module sends an error message to the head module and triggers an I/O-Group stop.

Further information on PSSu error messages is available in the online help for the PSS WIN-PRO system software.

7.2 Display elements

Legend:

☀	LED on
◐	LED flashes
●	LED off

7.2.1 Display elements for system diagnostics

The module has LEDs to display various PSSu states (“Usb” LED and “Dev” LED).

	LED			Key
	Description	Colour	Status	
	Usb	- - -	●	No data is being transmitted via the USB port
		Green	☀	Data is being transmitted via the USB port
	Dev	- - -	●	PSSu system error, no start-up
		Green	☀	PSSu running without error
		Red	☀	Error in the head module
		Red	◐	Error on the module bus (* ¹)

(*¹) An error on the module bus (flashing red LED) may be due to one of the following reasons, which are stored in the error stack:

1. The head module cannot determine the registered hardware. Possible causes:

- ▶ Module bus is incomplete
- ▶ Terminating resistor is missing.
- ▶ A module is defective
- ▶ A module does not have valid software.
- ▶ Invalid hardware registry
- ▶ Too many modules

7.2 Display elements

Remedy: Correct the hardware registry.

2. Error: A module is missing. Possible cause:

- ▶ The module has been removed.
- ▶ The module has an error and is no longer registering after a reset.
- ▶ The module has an error and switches to a system stop.
- ▶ The module no longer has a voltage supply.

Remedy: Rectify the above points.

7.2 Display elements

7.2.2 Display elements for SafetyBUS p diagnostics

The module has LEDs to display various SafetyBUS p states (“SB” LED and “I/O” LED).

	LED		Key	
	Designation	Colour		
	SB	---		No contact with SafetyBUS p (MD is not running or SBp wiring is faulty)
		Green		There is contact with SafetyBUS p, but the MD does not recognise the SBp-Device. (faulty device address or SBp configuration)
				Connection to MD is running correctly.
	I/O	---		All the SBp-Device's I/O-Groups are in a STOP condition.
			Green	
				All the SBp-Device's I/O-Groups are in a RUN condition

8.1 Technical details

Technical details	
Application range	Failsafe
Maximum achievable category in accordance with EN 954-1	4
Maximum achievable SIL value	SIL3
Module's device code	0220h
Electrical data	
Internal supply voltage	
Supply voltage range of module supply	4.9 - 5.1 V
Current and power consumption from module supply	
Module's current consumption without FO connection	205 mA
FO connection's current consumption	120 mA
Module's power consumption without FO connection	1.03 W
FO connection's power consumption	0.60 W
Max. power dissipation of the module	1.03 W
Potential isolation between module supply and SafetyBUS p	700 V
SafetyBUS p	
Application range	Failsafe applications
Device address	32d ... 95d
Max. transmission rate	500 kBit/s
Cable runs	3,500 m
Transmission type	differential two-wire cable
Connection	Male 9-pin D-SUB connector
USB	
Connection	Mini-B connector
Environmental data	
Climatic suitability	EN 60068-2-14, EN 60068-2-1, EN 60068-2-2, EN 60068-2-30, EN 60068-2-78
Ambient temperature	0 - 60 °C -40 - 70 °C coated version (-T)
Storage temperature	-25 - 70 °C -40 - 70 °C coated version (-T)
Climatic suitability in accordance with EN 60068-2-78	93 % r. h. at 40 °C
Condensation	no yes coated version (-T)
Max. operating height above sea level	5000 m coated version (-T)
EMC	EN 61000-4-2, EN 61000-4-3, EN 61000-4-4, EN 61000-4-5, EN 61000-4-6, EN 61000-6-2, EN 61000-6-4
Vibration to EN 60068-2-6	
Frequency	10 - 150 Hz
Max. acceleration	1g
Shock stress	
EN 60068-2-27	15g 11 ms
EN 60068-2-29	10g 16 ms
Protection type	
Mounting (e.g. cabinet)	IP54
Housing	IP20

8.1 Technical details

Environmental data

Airgap creepage in accordance with **EN 60664-1**

Overvoltage category **II**

Pollution degree **2**

Mechanical data

Housing material

Front **PC**

Bottom **PC**

Dimensions

Height **125.6 mm**

Width **50.2 mm**

Depth **72.6 mm**

Weight **135 g**

Safety characteristic data

Unit	Operating mode	EN ISO 13849-1 PL	EN 954-1 Category	EN IEC 62061 SIL CL	PFH [1/h]	t _M [year]
Logic	---	PL e (Cat. 4)	Cat. 4	SIL CL 3	2.88E-09	20

All the units used within a safety function must be considered when calculating the safety characteristic data.

8.2 Order reference

Order reference	
Description	Order no.
PSSu H SB (Head module with SafetyBUS p interface)	312 010
PSSu H SB-T (Head module with SafetyBUS p interface, coated version)	314 010



► ...
In many countries we are represented by our subsidiaries and sales partners.

Please refer to our homepage for further details or contact our headquarters.

Pilz GmbH & Co. KG
Felix-Wankel-Straße 2
73760 Ostfildern, Germany
Telephone: +49 711 3409-0
Telefax: +49 711 3409-133
E-Mail: pilz.gmbh@pilz.de
Internet: www.pilz.com

► Technical support

+49 711 3409-444
support@pilz.com

pilz

InduraneT p[®], Pilz[®], PIT[®], PMCprotego[®], PMI[®], PNOZ[®], Primo[®], PSEN[®], PSS[®], PVIS[®], SafetyBUS P[®], SafetyEYE[®], SafetyNET p[®], the spirit of safety[®] are registered and protected trademarks of Pilz GmbH & Co. KG in some countries. We would point out that product features may vary from the details stated in this document, depending on the status at the time of publication and the scope of the equipment. We accept no responsibility for the validity, accuracy and entirety of the text and graphics presented in this information. Please contact our Technical Support if you have any questions.