

PSSu H SB DP(-T)



Decentralised system PSSuniversal I/O

This document is a translation of the original document.

All rights to this documentation are reserved by Pilz GmbH & Co. KG. Copies may be made for internal purposes.

Suggestions and comments for improving this documentation will be gratefully received.

Pilz[®], PIT[®], PMI[®], PNOZ[®], Primo[®], PSEN[®], PSS[®], PVIS[®], SafetyBUS p[®], SafetyEYE[®], SafetyNET p[®], the spirit of safety[®] are registered and protected trademarks of Pilz GmbH & Co. KG in some countries.



SD means Secure Digital.

Contents		Page
Chapter 1 Introduction		
1.1	Validity of documentation	1-1
1.1.1	Retaining the documentation	1-1
1.2	Overview of documentation	1-2
1.3	Definition of symbols	1-3
Chapter 2 Overview		
2.1	Module features	2-1
2.2	Front view	2-2
Chapter 3 Safety		
3.1	Intended use	3-1
3.2	Safety regulations	3-3
3.2.1	Use of qualified personnel	3-3
3.2.2	Warranty and liability	3-3
3.2.3	Disposal	3-3
Chapter 4 Function description		
4.1	Module features	4-1
4.1.1	Integrated protection mechanisms	4-1
4.1.2	Supply voltage	4-1
4.2	SafetyBUS p	4-2
4.2.1	Connection to SafetyBUS p	4-2
4.2.2	Selector switch for setting the device address	4-2
4.3	PROFIBUS	4-3
4.3.1	Connection to PROFIBUS DP	4-3
4.3.2	Selector switch for setting the station address	4-4
4.4	USB port	4-5
Chapter 5 Installation		
5.1	General installation guidelines	5-1
5.1.1	Dimensions	5-1
5.2	Installing the head module	5-2
Chapter 6 Interfaces		
6.1	Interface configuration	6-1
6.1.1	Connection to SafetyBUS p	6-2
6.1.2	Connection to PROFIBUS	6-2
6.1.3	Connection via USB	6-2

Chapter 7 Operation

7.1	Messages	7-1
7.2	Display elements	7-3
7.2.1	Anzeigeelemente zur Systemdiagnose	7-3
7.2.2	Display elements for SafetyBUS p diagnostics	7-5
7.2.3	Display elements for PROFIBUS diagnostics	7-6

Chapter 8 Technical details

8.1	Technical details	8-1
8.2	Order reference	8-3

1.1 Validity of documentation

This documentation is valid for the product **PSSu H SB DP** and **PSSu H SB DP-T**. It is valid until new documentation is published.

Please also refer to the following documents:

- ▶ SafetyBUS p System Description
- ▶ SafetyBUS p Installation Manual
- ▶ PSSuniversal System Description
- ▶ PSSuniversal Installation Manual

This operating manual explains the function and operation, describes the installation and provides guidelines on how to connect the product .

1.1.1 Retaining the documentation

This documentation is intended for instruction and should be retained for future reference.

1.2 Overview of documentation

1 Introduction

The introduction is designed to familiarise you with the contents, structure and specific order of this manual.

2 Overview

This chapter provides information on the module's most important features.

3 Safety

This chapter must be read as it contains important information on safety and intended use.

4 Function Description

This chapter describes the module's individual components.

5 Installation

This chapter explains how to install the module.

6 Interfaces

This chapter describes the module's interfaces.

7 Operation

This chapter explains the display elements and advises on what to do if a fault occurs.

8 Technical Details

This chapter contains the product's technical details and order reference.

1.3 Definition of symbols

Information that is particularly important is identified as follows:



DANGER!

This warning must be heeded! It warns of a hazardous situation that poses an immediate threat of serious injury and death and indicates preventive measures that can be taken.



WARNING!

This warning must be heeded! It warns of a hazardous situation that could lead to serious injury and death and indicates preventive measures that can be taken.



CAUTION!

This refers to a hazard that can lead to a less serious or minor injury plus material damage, and also provides information on preventive measures that can be taken.



NOTICE

This describes a situation in which the unit(s) could be damaged and also provides information on preventive measures that can be taken. It also highlights areas within the text that are of particular importance.



INFORMATION

This gives advice on applications and provides information on special features.

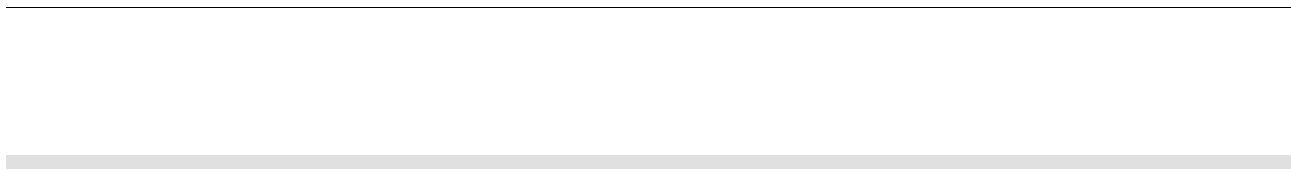

2.1 Module features

The product has the following features:

- ▶ **SafetyBUS p** interface for
 - Failsafe inputs/outputs
- ▶ **PROFIBUS DP** interface for
 - Standard inputs/outputs
 - Failsafe outputs with the local enable principle
- ▶ USB port for connection to a PC for
 - Commissioning
 - Service
- ▶ LEDs for:
 - System status
 - **SafetyBUS p** status
 - USB status
 - Status of the **PROFIBUS DP** interface
- ▶ Electronic modules that can be used for input/output:
 - All failsafe modules (PSSu E F...)
 - All standard modules (PSSu E S...)
- ▶ Coated version of the module:
 - **PSSu H SB DP-T**: for increased environmental requirements

2.2 Front view

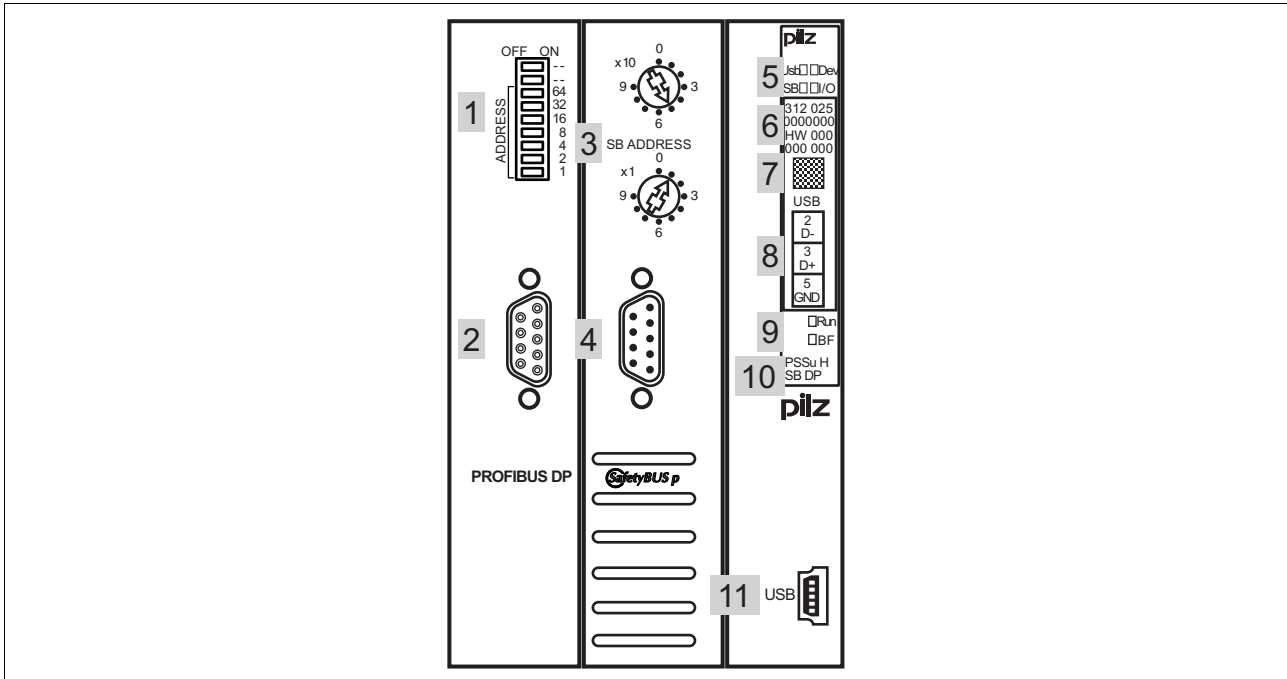

Key:

- ▶ 1: Selector switch for setting the station address (PROFIBUS-DP)
- ▶ 2: PROFIBUS DP interface
- ▶ 3: Two selector switches for setting the device address (SafetyBUS p)
- ▶ 4: SafetyBUS p interface
- ▶ 5: LEDs for system diagnostics and SafetyBUS p diagnostics
- ▶ 6: Labelling strip with:
 - Order number
 - Serial number
 - Hardware version number
 - Firmware version number on delivery
- ▶ 7: Field for 2D code
- ▶ 8: Labelling strip with interface configuration of the USB port
- ▶ 9: LEDs for PROFIBUS DP diagnostics
- ▶ 10: Description of head module
- ▶ 11: USB port (Mini-B)

3.1 Intended use

The module is designed for use in:

- ▶ Safety-related applications with
 - **SafetyBUS p**
 - **PROFIBUS DP** With local enable principle
- ▶ Non-safety-related applications with
 - **PROFIBUS DP**

The module **PSSu H SB DP-T** is suitable for use where there are increased environmental requirements (see Technical Details).

The module meets the requirements of EN IEC 61508 up to **SIL3** and EN 954-1 up to Category **4**.

Intended use includes making the electrical installation EMC-compliant. Please refer to the guidelines stated in the "PSSuniversal Installation Manual". The module is designed for use in an industrial environment. It is not suitable for use in a domestic environment, as this can lead to interference.

The following is deemed improper use in particular:

- ▶ Any component, technical or electrical modification to the module
- ▶ Use of the module outside the areas described in this manual
- ▶ Use of the module outside the technical details (see chapter entitled "Technical Details")



INFORMATION

The module is supported by the PSSuniversal Configurator and PSSuniversal Assistant from Version 1.4.0. We recommend that you always use the latest version (download from www.pilz.de). The module is supported by programmable safety systems with SafetyBUS p interface, from FS operating system version 50/18.

Programmable safety systems with an older FS operating system version will have a restricted function range.

3.1 Intended use

The head module may be used in conjunction with the following electronic modules:

Module type	Module name
Voltage supply	PSSu E F PS(-T)
	PSSu E F PS1(-T)
	PSSu E F PS-P(-T)
	PSSu E F BSW(-T)
Digital input/output modules	PSSu E S 4DI(-T)
	PSSu E S 4DO 0.5(-T)
	PSSu E S 2DO 2(-T)
	PSSu E F 4DI(-T)
	PSSu E F 4DO 0.5(-T)
	PSSu E F 2DO 2(-T)
	PSSu E F 2DOR 8(-T)
	PSSu E F DI OZ 2(-T)
Analogue input/output modules	PSSu E S 2AI I se(-T)
	PSSu E S 4AI U(-T)
	PSSu E S 2AI U(-T)
	PSSu E S 2AO I(-T)
	PSSu E S 4AO U(-T)
	PSSu E S 2AO U(-T)
Counter modules	PSSu E S ABS SSI(-T)
	PSSu E S INC(-T)
Voltage distribution	PSSu E PD(-T)
	PSSu E PD1(-T)

The module's firmware can be updated to a later version using the Firmware Manager on the PSSuniversal Assistant. For the reason, the module's actual firmware version may not always match the firmware version printed on the front of the unit. Updating the firmware can also expand the module's functionality.



INFORMATION

The module's actual firmware version can only be established using the Firmware Manager on the PSSuniversal Assistant.

3.2 Safety regulations

3.2.1 Use of qualified personnel

The products may only be assembled, installed, programmed, commissioned, operated, maintained and decommissioned by competent persons.

A competent person is someone who, because of their training, experience and current professional activity, has the specialist knowledge required to test, assess and operate the work equipment, devices, systems, plant and machinery in accordance with the general standards and guidelines for safety technology.

It is the company's responsibility only to employ personnel who:

- ▶ Are familiar with the basic regulations concerning health and safety / accident prevention
- ▶ Have read and understood the safety guidelines given in this description
- ▶ Have a good knowledge of the generic and specialist standards applicable to the specific application.

3.2.2 Warranty and liability

All claims to warranty and liability will be rendered invalid if:

- ▶ The product was used contrary to the purpose for which it is intended
- ▶ Damage can be attributed to not having followed the guidelines in the manual
- ▶ Operating personnel are not suitably qualified
- ▶ Any type of modification has been made (e.g. exchanging components on the PCB boards, soldering work etc.).

3.2.3 Disposal

- ▶ In safety-related applications, please comply with the mission time t_M in the safety-related characteristic data.
- ▶ When decommissioning, please comply with local regulations regarding the disposal of electronic devices (e.g. Electrical and Electronic Equipment Act).

4 Function description

4.1 Module features

4.1.1 Integrated protection mechanisms

The module has the following protection mechanisms:

- ▶ Multi-channel diverse processor section
- ▶ Cyclical self tests
- ▶ Potentially isolated **SafetyBUS p** interface
- ▶ Potentially isolated **PROFIBUS DP** interface
- ▶ When the PSSu E F PS1(-T) is used to supply the system, the module supply is buffered for 20 ms if the supply voltage is interrupted.

4.1.2 Supply voltage

Module supply

- ▶ The module supply provides the module with voltage.

4.2 SafetyBUS p

4.2.1 Connection to SafetyBUS p

A PSSu with SafetyBUS p interface is regarded as a bus subscriber in a SafetyBUS p network.

The “SafetyBUS p Installation Manual” and the “SafetyBUS p System Description” apply for subscribers in a SafetyBUS p network.

Detailed descriptions for commissioning are available in the online help for the PSS WIN-PRO system software. Step-by-step instructions can be found in the manual: "Getting Started: Full version of PSS WIN-PRO".

4.2.2 Selector switch for setting the device address

The device address of a PSSu is set via the two rotary switches “x 10” and “x 1”.

Permitted device addresses are in the range $32_D \dots 95_D$. The same applies if the PSSu system is configured for SafetyBUS p 1 in the SafetyBUS p Configurator on the PSS WIN-PRO system software. The offset of 100_D for device addresses on SafetyBUS p 1 is calculated automatically from the bus configuration.

Rotary switch “SB ADDRESS”: Switch designation	Key	Example: Device address 51_D
x 10	Set the tens	
x 1	Set the units	

4.3 PROFIBUS

4.3.1 Connection to PROFIBUS DP

The PSSu system with PROFIBUS interface is a passive PROFIBUS DP subscriber (Slave). The basic functions of communication with PROFIBUS DP correspond to EN 50170.

The specifications of the PROFIBUS User Group (PNO) apply for a PSSu.

The data length of the output data may be a max. of 1536 Bytes because the memory of the PROFIBUS protocol chips is 1.5 kByte. The max. data length is calculated as:

- ▶ 3 x length of the input data
- ▶ + 3 x length of the output data
- ▶ + 2 x length of the diagnostic data
- ▶ + 4 x length of the configuration data
- ▶ + 64 Byte

4.3 PROFIBUS

4.3.2 Selector switch for setting the station address

The station address of a PSSu is set via the “ADDRESS” DIP switch. The DIP switch is binary coded. Permitted station addresses are in the range $0_D \dots 125_D$.

If station address 126_D is set via the DIP switch, the address can be assigned via the Master. The Set Slave Address command (SSA) must be run for this purpose.

The station address is set as follows:

DIP switch “ADDRESS”	Key		Example:
	OFF	ON	
Switch designation			Station address 52_D
--	Not connected		
--			
64	0	64_D	
32	0	32_D	
16	0	16_D	
8	0	8_D	
4	0	4_D	
2	0	2_D	
1	0	1_D	



INFORMATION

The station address should **only** be set when the module is switched off (no voltage applied).

The settings are **only** transferred when booting. Any changes made to the settings during operation will **not** be transferred.

4.4 USB port

The following functions are available via the USB port:

- ▶ Show actual hardware
- ▶ Comparison of actual/registered hardware
- ▶ Display and update firmware versions
- ▶ Setting the parameters for the ST section

Parameters for the module's ST section can either be set via the fieldbus interface or via the USB port. Parameter setting via the USB port has priority over parameter setting via the fieldbus interface. Once parameters for the the head module have been set via the USB port, the ability to set parameters for the module via the fieldbus interface is disabled. The disable can be lifted in the PSSuniversal Assistant.

Procedure for connecting the head module via the USB port:

- ▶ Connect PC to head module via USB cable.
- ▶ Install USB driver.
- ▶ View the actual hardware registry in the PSSuniversal Assistant and call up other functions.

This way it is possible to copy and edit an existing configuration in the PSSuniversal Assistant.



INFORMATION

The USB driver can be found on the PSSuniversal Assistant CD-ROM, in the subdirectory \bin\PILZ_USB_DRIVER

4 Function description

5.1 General installation guidelines

Please also refer to the PSSuniversal Installation Manual.

The description below assumes that the mounting rail is already installed.



CAUTION!

Damage due to electrostatic discharge!

Electrostatic discharge can damage components. Ensure against discharge before touching the product, e.g. by touching an earthed, conductive surface or by wearing an earthed arm-band.

5.1.1 Dimensions

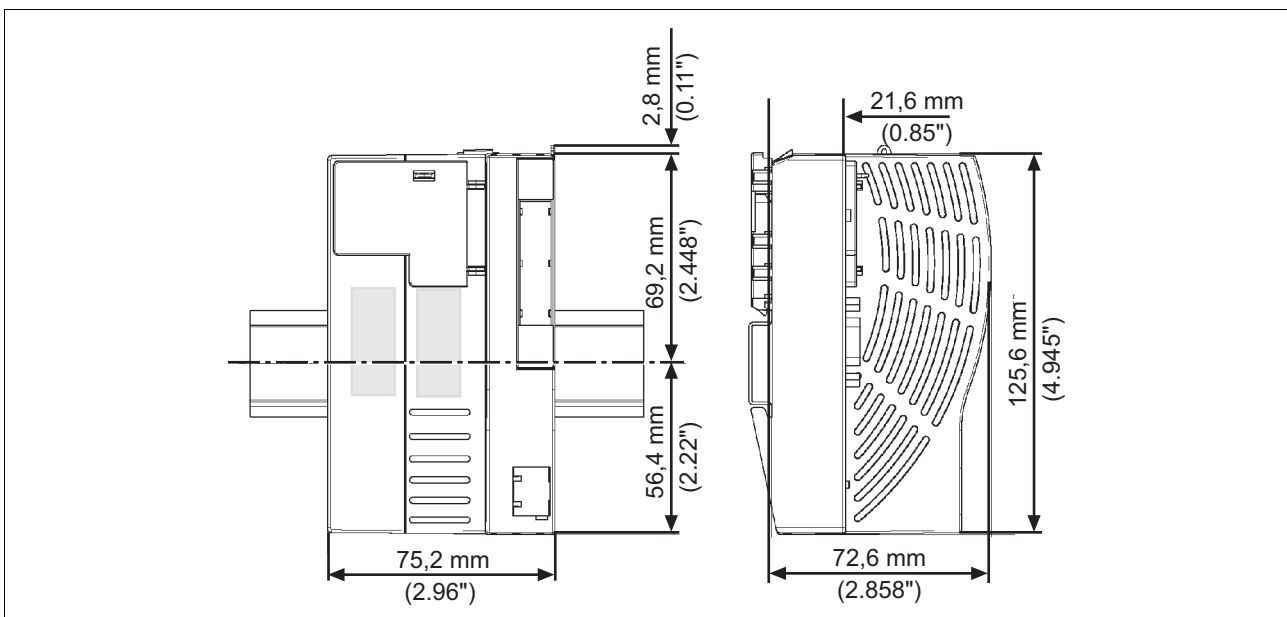

5.2 Installing the head module

Prerequisite:

- ▶ The mounting rail must be installed.

Procedure:

- ▶ Install an end bracket to the left of the head module or leave enough space for one.
- ▶ Slot the groove on the head module on to the mounting rail from below [1].
- ▶ Push the head module back [2] until you hear it lock into position.

Schematic representation:

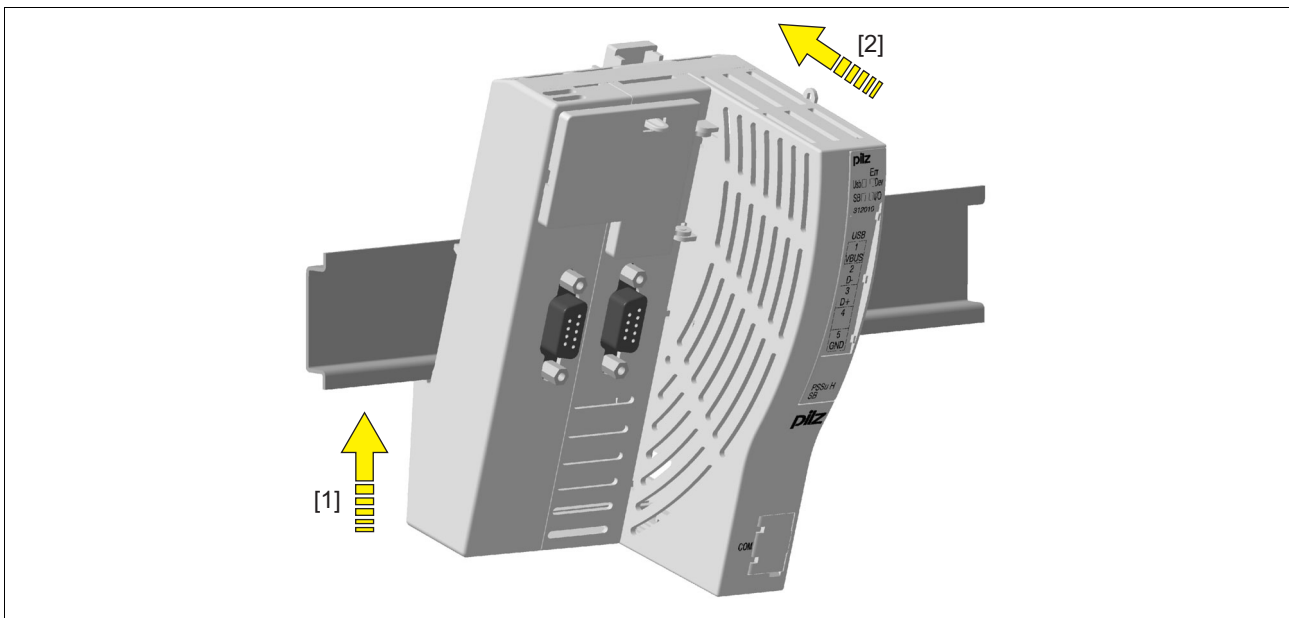

6.1 Interface configuration

SafetyBUS p	Layout	
Male 9-pin D-SUB connector	1: n.c. 2: CAN_L (brown) 3: CAN_GND (white) 4: n.c. 5: CAN_SHLD 6: n.c. 7: CAN_H (green) 8: Supply voltage for fibre-optic cou- plers from Pilz 9: n.c.	
PROFIBUS-DP	Layout	
Female 9-pin D-SUB connector con- forms to the guidelines of the PROFI- BUS User Group (PNO)	1: n.c. 2: n.c. 3: RxD/TxD-P (B-line) 4: CNTR-P (RTS) 5: DGND (GND ext.) 6: VP (+5 V ext.) 7: n.c. 8: RxD/TxD-N (A-line) 9: n.c.	
USB	Layout	
Mini-B USB connector	1: n.c. 2: D- USB Data - 3: D+ USB Data + 4: n.c. 5: GND Ground	

► n.c. = not connected

6.1 Interface configuration

6.1.1 Connection to SafetyBUS p

Please refer to the SafetyBUS p Installation Manual.

6.1.2 Connection to PROFIBUS

The PSSu is connected to PROFIBUS DP via RS 485 communication. The PSSu supplies the PROFIBUS DP bus terminating resistors with voltage (+5 VDC).



INFORMATION

The two data lines are also called A and B on PROFIBUS. Always connect the A-line ("RxD/TxD-N") to the A-lines of all the other PROFIBUS subscribers.

The B-line ("RxD/TxD-P") should only be connected to the B-lines of the other PROFIBUS subscribers.

If communication is not established, check the connections using a continuity tester.

- ▶ Connect the connector housing to the screening on the PROFIBUS cable. The connector housing should be connected with low impedance to the mounting rail.



CAUTION!

Do not use the signals VP (+5 V ext.) and DGND (GND ext.) to supply voltage to external devices! They are exclusively used to supply the PROFIBUS DP bus terminating resistors.

6.1.3 Connection via USB

Please note the requirements of the USB standard for USB 2.0 and for Mini-B USB ports.

The maximum cable runs for USB connection cable are 5 m.

7.1 Messages

All errors and faults detected by the electronic modules on a PSSu are signalled to the head module and entered in the head module's error stack. You can read the head module's error stack using the PSS WIN-PRO system software (SafetyBUS p, Domain 0).

Module error	Statement	Remedy
Start-up error	Error as the PSSu system starts up	Change faulty module
Configuration error	Incorrect module type configured	The configured hardware registry does not match the actual hardware registry
FS communication error	Error during FS communication	Change faulty module
ST communication error	Error during ST communication	Change faulty module
Bus termination error	There is no terminating plate or there is a bad contact with the module bus	Install a terminating plate with integrated end bracket or insert the base modules together correctly
Temperature error: too warm ⁽¹⁾	Ambient temperature too high: Error stack entry	Ensure there is sufficient ventilation in the control cabinet or prevent overload
Temperature error: too hot ⁽¹⁾	Ambient temperature too high: Reset the module and stop the affected I/O-Groups (SafetyBUS p)	Ensure there is sufficient ventilation in the control cabinet or prevent overload
Output error	Error during cyclical output test for short circuit. Possible causes: Short circuit, or output defective	Rectify the short circuit or change the faulty module
Test pulse error	Possible causes: Short circuit between a test pulse and a supply voltage, or a defective module	Rectify the short circuit or change the faulty module
Relay control error	Error during cyclical monitoring test of the relay coils	Change faulty relay module
Relay error	A relay position is faulty; possible cause: Defective relay contact	Change faulty relay module
Block switching output error	Error during cyclical monitoring test of the relay contacts; possible external cause: Voltages being fed back to the relay contacts	Check the supply voltage and the wiring
Error in the feedback loop	FS input detects an error in the feedback loop or FS input is defective	Check FS input, check the configuration of the feedback loop, check the signals, or check the wiring and contacts
Error in the local enable principle	FS output has reacted incorrectly or unexpectedly	Check the configuration of the FS output, or check the fieldbus signals in the FS and ST section
Input error	Error during the cyclical input test; possible cause: Input defective	Change faulty module
Overload/short circuit	Load on output too high	Rectify overload or short circuit

7.1 Messages

Module error	Statement	Remedy
Overload of the supply voltage for encoder	Supply voltage for encoder overloaded or short-circuited	Rectify overload or short circuit
Overvoltage error	A system voltage or infeed is too high	Stabilise the supply or change the faulty supply voltage module
Undervoltage error	A system voltage or infeed is too low	Stabilise the supply or change the faulty supply voltage module
Error in the overvoltage protection diodes	Overvoltage protection diodes are defective	Change faulty supply voltage module
Timeout error on the output	No data has been received for the output from the module bus for longer than 50 ms.	Check ST communication or configuration
Polarity error	Polarity of the periphery supply	Correct the polarity
Error in the periphery supply	Lower voltage limit exceeded on the periphery supply	Ensure there is a sufficient supply

(¹) There are two levels of overtemperature.

▶ Too warm:

If a module's temperature exceeds a threshold value, the module sends a warning to the head module. If the temperature drops back below the threshold value, the module sends an all-clear.

▶ Too hot:

If a module's temperature exceeds a further threshold value, the module sends an error message to the head module and triggers an I/O-Group stop.

Further information on PSSu error messages is available in the online help for the system software.

7.2 Display elements

Legend:

☀	LED on
◐	LED flashes
●	LED off

7.2.1 Anzeigeelemente zur Systemdiagnose

The module has LEDs to display various PSSu states (“Usb” LED and “Dev” LED).

	LED			Key
	Description	Colour	Status	
	Usb	- - -	●	No data is being transmitted via the USB port
		Green	☀	Data is being transmitted via the USB port
	Dev	- - -	●	PSSu system error, no start-up
		Green	☀	PSSu running without error
		Red	☀	Error in the head module
		Red	◐	Error on the module bus (* ¹)

(*¹) An error on the module bus (flashing red LED) may be due to one of the following reasons, which are stored in the error stack:

1. The head module cannot determine the registered hardware. Possible causes:

- ▶ Module bus is incomplete
- ▶ Terminating resistor is missing.
- ▶ A module is defective
- ▶ A module does not have valid software.
- ▶ Invalid hardware registry
- ▶ Too many modules

7.2 Display elements

Remedy: Correct the hardware registry.

2. Error: A module is missing. Possible cause:

- ▶ The module has been removed.
- ▶ The module has an error and is no longer registering after a reset.
- ▶ The module has an error and switches to a system stop.
- ▶ The module no longer has a voltage supply.

Remedy: Rectify the above points.

7.2 Display elements

7.2.2 Display elements for SafetyBUS p diagnostics

The module has LEDs to display various SafetyBUS p states (“SB” LED and “I/O” LED).

	LED		Key	
	Designation	Colour		
	SB	---		No contact with SafetyBUS p (MD is not running or SBp wiring is faulty)
		Green		There is contact with SafetyBUS p, but the MD does not recognise the SBp-Device. (faulty device address or SBp configuration)
				Connection to MD is running correctly.
	I/O	---		All the SBp-Device's I/O-Groups are in a STOP condition.
		Green		One of the SBp-Device's I/O-Groups is in a STOP condition.
				All the SBp-Device's I/O-Groups are in a RUN condition

7.2 Display elements

7.2.3 Display elements for PROFIBUS diagnostics

The module has LEDs to display various PROFIBUS DP states (“BF” LED and “Run” LED).

	LED for PROFIBUS DP diagnostics		Key
	“BF” status (red)	“Run” status (green)	
	●	●	No supply voltage or PROFIBUS interface start-up is not yet complete.
	☀	●	Bus error on PROFIBUS
	◐	●	Invalid station address.
	◑	☀	PROFIBUS diagnostics prior to data transfer
	◐	◑	Fatal error (PROFIBUS)
	●	◐	Static PROFIBUS diagnostics during data transfer
	●	☀	Data is being transmitted.

8.1 Technical details

Technical details	
Application range	Standard/Failsafe
Maximum achievable category in accordance with EN 954-1	4
Maximum achievable SIL value	SIL3
Module's device code	0221h
Electrical data	
Internal supply voltage	
Supply voltage range of module supply	4.9 - 5.1 V
Current and power consumption from module supply	
Module's current consumption without FO connection	450 mA
FO connection's current consumption	120 mA
Module's power consumption without FO connection	2.25 W
FO connection's power consumption	0.60 W
Max. power dissipation of the module	2.25 W
Potential isolation between module supply and PROFIBUS DP	700 V
Potential isolation between module supply and SafetyBUS p	700 V
SafetyBUS p	
Application range	Failsafe applications
Device address	32d ... 95d
Max. transmission rate	500 kBit/s
Cable runs	3,500 m
Transmission type	differential two-wire cable
Connection	Male 9-pin D-SUB connector
PROFIBUS DP	
Application range	Standard applications Failsafe applications with local enable principle
Device type	Slave
Station address	0 ... 126d
Set via	DIP switch
Maximum data length of the fieldbus interface: Input	64 Byte
Maximum data length of the fieldbus interface: Output	64 Byte
Maximum data length of the fieldbus interface: Diagnostics	64 Byte
Transmission rates	1.5 MBit/s, 12 MBit/s, 185.5 kBit/s, 19.2 kBit/s, 3 MBit/s, 45.45 kBit/s, 500 kBit/s, 6 MBit/s, 9.6 kBit/s, 93.75 kBit/s
Set via	automatic
Connection	Female 9-pin D-SUB connector
Protocol	DPV0
Operating modes	AutoBaud, Freeze Mode, Set Slave Address, Sync Mode
Certification	PNO
Description file	PILZ092F.GSD
Manufacturer's ID	092Fh
USB	
Connection	Mini-B connector

8.1 Technical details

Environmental data	
Climatic suitability	EN 60068-2-14, EN 60068-2-1, EN 60068-2-2, EN 60068-2-30, EN 60068-2-78
Ambient temperature	0 - 60 °C
Storage temperature	-40 - 70 °C coated version (-T)
Climatic suitability in accordance with EN 60068-2-78	-25 - 70 °C
Condensation	-40 - 70 °C coated version (-T)
Max. operating height above sea level	93 % r. h. at 40 °C
EMC	no
Vibration to EN 60068-2-6	yes coated version (-T)
Frequency	5000 m coated version (-T)
Max. acceleration	EN 61000-4-2, EN 61000-4-3, EN 61000-4-4, EN 61000-4-5, EN 61000-4-6, EN 61000-6-2, EN 61000-6-4
Shock stress	10 - 150 Hz
EN 60068-2-27	1g
EN 60068-2-29	15g 11 ms 10g 16 ms
Protection type	
Mounting (e.g. cabinet)	IP54
Housing	IP20
Airgap creepage in accordance with EN 60664-1	
Overvoltage category	II
Pollution degree	2
Mechanical data	
Housing material	
Front	PC
Bottom	PC
Dimensions	
Height	128.4 mm
Width	75.2 mm
Depth	79.4 mm
Weight	170 g

Safety characteristic data						
Unit	Operating mode	EN ISO 13849-1 PL	EN 954-1 Category	EN IEC 62061 SIL CL	PFH [1/h]	t _M [year]
Logic	---	PL e (Cat. 4)	Cat. 4	SIL CL 3	2.88E-09	20

All the units used within a safety function must be considered when calculating the safety characteristic data.

8.2 Order reference

Order reference	
Description	Order no.
PSSu H SB DP (Head module with SafetyBUS p interface and PROFIBUS DP interface)	312 025
PSSu H SB DP-T (Head module with SafetyBUS p interface and PROFIBUS DP interface, coated version)	314 025



► ...
In many countries we are represented by our subsidiaries and sales partners.

Please refer to our homepage for further details or contact our headquarters.

Pilz GmbH & Co. KG
Felix-Wankel-Straße 2
73760 Ostfildern, Germany
Telephone: +49 711 3409-0
Telefax: +49 711 3409-133
E-Mail: pilz.gmbh@pilz.de
Internet: www.pilz.com

► Technical support

+49 711 3409-444
support@pilz.com

pilz

InduraneT p[®], Pilz[®], PIT[®], PMCprotego[®], PMI[®], PNOZ[®], Primo[®], PSEN[®], PSS[®], PVIS[®], SafetyBUS P[®], SafetyEYE[®], SafetyNET p[®], the spirit of safety[®] are registered and protected trademarks of Pilz GmbH & Co. KG in some countries. We would point out that product features may vary from the details stated in this document, depending on the status at the time of publication and the scope of the equipment. We accept no responsibility for the validity, accuracy and entirety of the text and graphics presented in this information. Please contact our Technical Support if you have any questions.