



▶ PSSu H PLC1 FS SN SD (M12) (-T)(-R)

PILZ
THE SPIRIT OF SAFETY

Operating Manual-21939-EN-20
- Control system PSSuniversal PLC



This document is the original document.

Where unavoidable, for reasons of readability, the masculine form has been selected when formulating this document. We do assure you that all persons are regarded without discrimination and on an equal basis.

All rights to this documentation are reserved by Pilz GmbH & Co. KG. Copies may be made for the user's internal purposes. Suggestions and comments for improving this documentation will be gratefully received.

Pilz®, PIT®, PMI®, PNOZ®, Primo®, PSEN®, PSS®, PVIS®, SafetyBUS p®, SafetyEYE®, SafetyNET p®, the spirit of safety® are registered and protected trademarks of Pilz GmbH & Co. KG in some countries.



SD means Secure Digital

1	Introduction	5
1.1	Validity of documentation	5
1.1.1	Retaining the documentation	5
1.2	Using the documentation	5
1.3	Definition of symbols	5
1.4	Third-party manufacturer licence information	6
2	Overview	7
2.1	Module features	7
2.2	Front view	8
3	Safety	10
3.1	Intended use	10
3.2	Safety regulations	12
3.2.1	Safety assessment	12
3.2.2	Use of qualified personnel	12
3.2.3	Warranty and liability	12
3.2.4	Disposal	12
4	Function description	13
4.1	Block diagram	13
4.2	Control system	13
4.3	Supply voltage	14
4.3.1	Function description	14
4.3.2	Current load capacity	14
4.4	Integrated protection mechanisms	16
4.5	SD card	17
4.6	Reset button	17
4.7	SafetyNET p	18
4.7.1	Connection to SafetyNET p	18
4.8	External communication	18
5	Installation	19
5.1	General installation guidelines	19
5.2	Dimensions	19
5.3	Installing the head module	20
6	Interface assignment	21
7	Wiring	22
7.1	General wiring guidelines	22
7.2	Terminal configuration	22
7.3	Connecting the module	23
8	Operation	25
8.1	Messages	25
8.2	Display elements	25
8.2.1	MBUS	26

8.2.2	SD CARD	27
8.2.3	ST RUN	28
8.2.4	FS RUN	29
8.2.5	DIAG	30
8.2.6	ST FORCE	31
8.2.7	FS FORCE	32
8.2.8	MS	33
8.2.9	NS/BF	34
8.2.10	ST SNp	35
8.2.11	FS SNp	36
8.2.12	5V, 24V	37
8.2.13	X3: LNK, X3: TRF, X4: LNK, X4: TRF	38
9	Technical details Order no. 312070, 314070, 314071	39
10	Technical details Order no. 315070, 315071	44
11	Safety characteristic data	49
12	Supplementary data	50
12.1	Permitted operating height	50
13	Order reference	51
13.1	Product	51
13.2	Accessories	51
14	EC declaration of conformity	52
15	UKCA-Declaration of Conformity	53

1 Introduction

1.1 Validity of documentation

The documentation is valid for the product types:

- ▶ PSSu H PLC1 FS SN SD
- ▶ PSSu H PLC1 FS SN SD-T
- ▶ PSSu H PLC1 FS SN SD M12-T
- ▶ PSSu H PLC1 FS SN SD-R
- ▶ PSSu H PLC1 FS SN SD M12-R
- ▶ It is valid until new documentation is published.

Please also refer to the following documents:

- ▶ System Description PSS 4000
- ▶ PSSuniversal Installation Manual

This operating manual explains the function and operation, describes the installation and provides guidelines on how to connect the product.

1.1.1 Retaining the documentation

This documentation is intended for instruction and should be retained for future reference.

1.2 Using the documentation

This document is intended for instruction. Only install and commission the product if you have read and understood this document. The document should be retained for future reference.

1.3 Definition of symbols

Information that is particularly important is identified as follows:



DANGER!

This warning must be heeded! It warns of a hazardous situation that poses an immediate threat of serious injury and death and indicates preventive measures that can be taken.



WARNING!

This warning must be heeded! It warns of a hazardous situation that could lead to serious injury and death and indicates preventive measures that can be taken.



CAUTION!

This refers to a hazard that can lead to a less serious or minor injury plus material damage, and also provides information on preventive measures that can be taken.



NOTICE

This describes a situation in which the product or devices could be damaged and also provides information on preventive measures that can be taken. It also highlights areas within the text that are of particular importance.



INFORMATION

This gives advice on applications and provides information on special features.

1.4

Third-party manufacturer licence information

This product includes Open Source software with various licenses.

Further information is available in the document „Third-party manufacturer licence information PSS 4000-exclusive devices“ (document number 1003883) at www.pilz.com.

2 Overview

2.1 Module features

The head module belongs to the performance class "Control system PSSu PLC". It can be used to connect a PSSu system to SafetyNET p or for non-safety-related applications it can be incorporated into a PROFINET project as an IO device.

The head module has the following features:

- ▶ 2 free switch ports for connection to SafetyNET p
- ▶ External connections:
 - Modbus/TCP
 - Raw UDP
 - Raw TCP
 - EtherNet/IP
 - PROFINET
- ▶ One FS resource and one ST resource
- ▶ SD card used to store the device project and the naming data
- ▶ Reset button
 - For warm reset
 - To transfer the naming data and/or device project from the SD card to the device memory
- ▶ Supply voltage
 - Integrated supply voltage for periphery supply and module supply
 - Module supply is buffered for 20 ms if the supply voltage is interrupted
 - Plug-in connection terminals (either spring-loaded terminal or screw terminal)
- ▶ Status LEDs
- ▶ Supports FS and ST modules
- ▶ T-type:
PSSu H PLC1 FS SN SD (M12)-T: For increased environmental requirements
- ▶ R-type:
PSSu H PLC1 FS SN SD (M12)-R: For railway applications

2.2 Front view

Front view of head modules with an RJ45 female connector

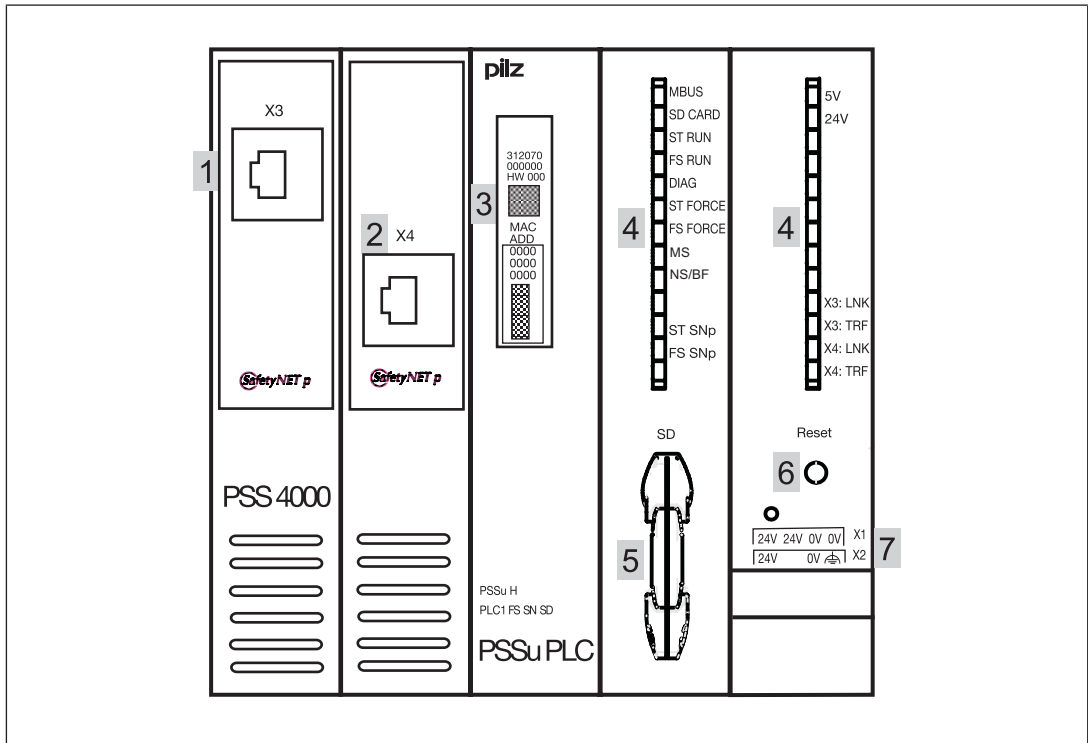

Front view of head modules with an M12 female connector

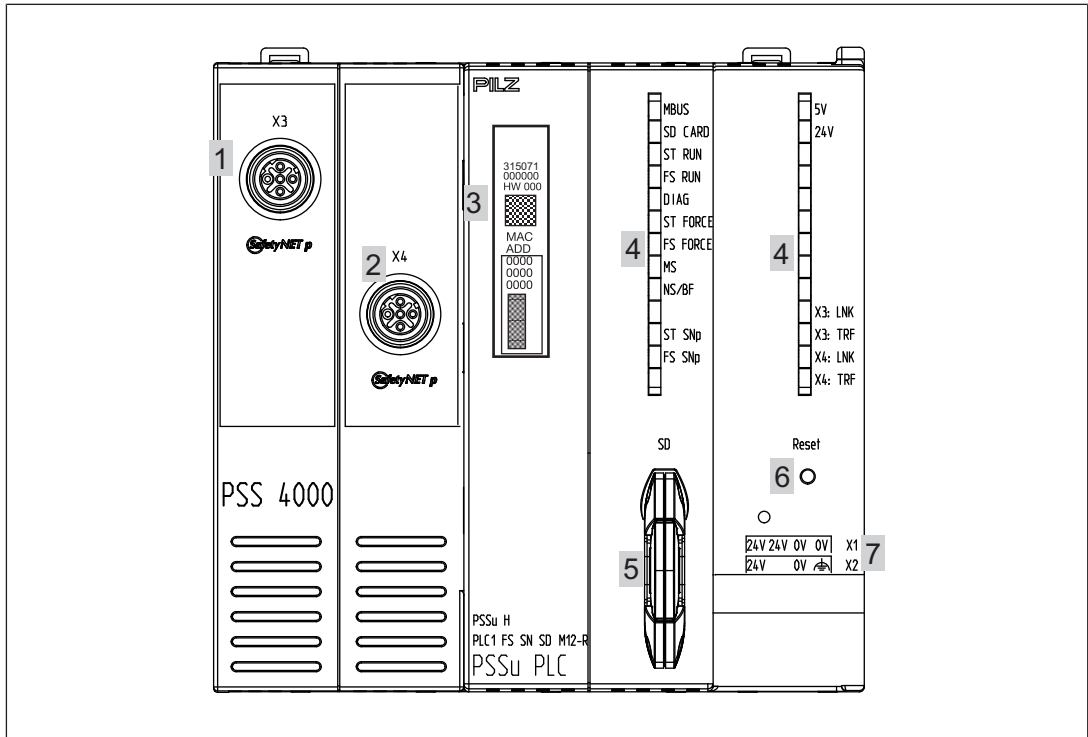

Legend

- 1 Ethernet Port
- 2 Ethernet Port
- 3 Labelling strip (see below for details)
- 4 Status LEDs
- 5 SD card
- 6 Reset pushbutton
- 7 Supply voltage connection (module and periphery supply)

The labelling strip contains the following information:

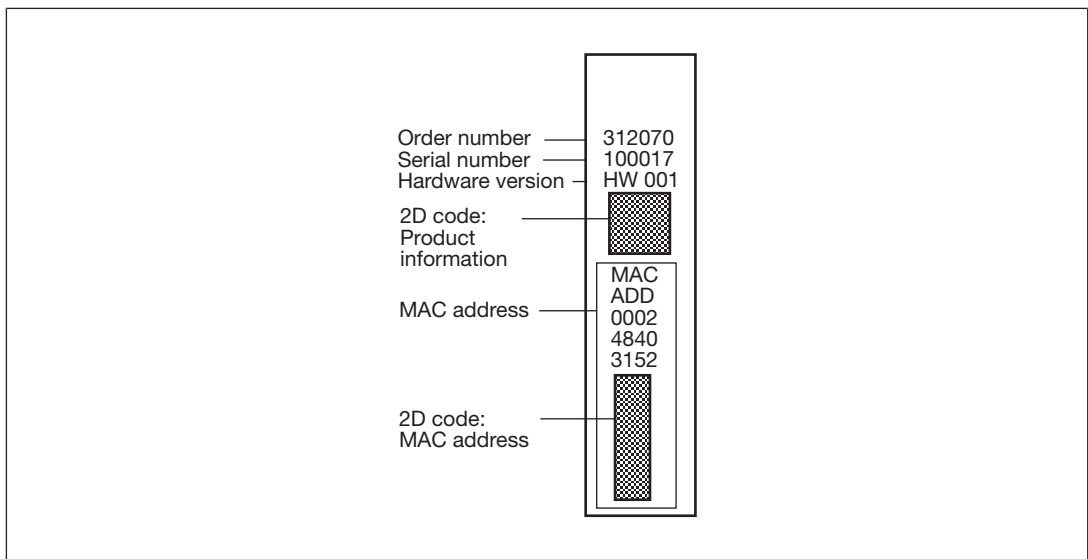

3 Safety

3.1 Intended use



INFORMATION

If the module name is not explicitly named, the details apply to all the variants of the module.

Failsafe and standard applications

The module is suitable for use in safety and non-safety-related applications, with and without **SafetyNET p** or in non-safety-related applications with PROFINET IO.

Please note that only head modules with a "BF"-LED are used with PROFINET IO.

Particular application areas

► Increased environmental requirements

The module PSSu H PLC1 FS SN SD (M12)-T is suitable for use where there are increased environmental requirements (see [Technical details \[39\]](#)).

► Lift applications

The modules PSSu H PLC1 FS SN SD and PSSu H PLC1 FS SN SD-T can be used as a PESSRAL (programmable electronic system in safety-related applications for lifts) in accordance with the Lifts Directive 2014/33/EU. The modules meet the requirements in accordance with EN 81-20, EN 81-50 for passenger and goods lifts the requirements in accordance with EN 115-1 for escalators and moving walks.

The module/the safety controller should be installed in a protected environment. Example: Protected inside space or control cabinet with protection class and corresponding air conditioning specified in [Technical details \[39\]](#).

► Railway applications

The module PSSu H PLC1 FS SN SD (M12)-R is **only** intended and certified for use in railway applications (CENELEC) where there are increased environmental requirements (see [Technical details \[39\]](#)). Any other use is **not** permitted.

Permitted operating height

With reference to the standard IEC 61131-2 the values stated in the technical details for ambient temperature are reduced at heights >2000 m operating height above sea level (see [Supplementary data \[50\]](#)).

EMC-compliant installation

Intended use includes making the electrical installation EMC-compliant. Please refer to the guidelines stated in the "PSSuniversal Installation Manual". The module is intended for use in an industrial environment. Interference may occur if used within a domestic environment.

Improper use

The following is deemed improper use in particular

- ▶ Any component, technical or electrical modification to the module,
- ▶ Use of the module outside the areas described in this operating manual,
- ▶ Any use of the module that is not in accordance with the technical details.

Software tools

The module can be configured and programmed with PAS4000.



INFORMATION

We recommend that you always use the latest version of the software tool (download from www.pilz.com).

3.2 Safety regulations

3.2.1 Safety assessment

Before using a device, a safety assessment in accordance with the Machinery Directive is required.

The product as an individual component fulfils the functional safety requirements in accordance with EN ISO 13849 and EN IEC 62061. However, this does not guarantee the functional safety of the overall plant/machine. To achieve the relevant safety level of the overall plant/machine's required safety functions, each safety function needs to be considered separately.

3.2.2 Use of qualified personnel

The products may only be assembled, installed, programmed, commissioned, operated, maintained and decommissioned by persons who are competent to do so.

A competent person is a qualified and knowledgeable person who, because of their training, experience and current professional activity, has the specialist knowledge required. In order to inspect, assess and handle products, devices, systems, plant and machinery, this person must be familiar with the state of the art and the applicable national, European and international laws, directives and standards.

It is the company's responsibility only to employ personnel who

- ▶ Are familiar with the basic regulations concerning health and safety / accident prevention,
- ▶ Have read and understood the information provided in the section entitled Safety
- ▶ Have a good knowledge of the generic and specialist standards applicable to the specific application.

3.2.3 Warranty and liability

All claims to warranty and liability will be rendered invalid if

- ▶ The product was used contrary to the purpose for which it is intended,
- ▶ Damage can be attributed to not having followed the guidelines in the manual,
- ▶ Operating personnel are not suitably qualified,
- ▶ Any type of modification has been made (e.g. exchanging components on the PCB boards, soldering work etc.).

3.2.4 Disposal

- ▶ In safety-related applications, please comply with the mission time T_M in the safety-related characteristic data.
- ▶ When decommissioning, please comply with local regulations regarding the disposal of electronic devices (e.g. Electrical and Electronic Equipment Act).

4 Function description

4.1 Block diagram

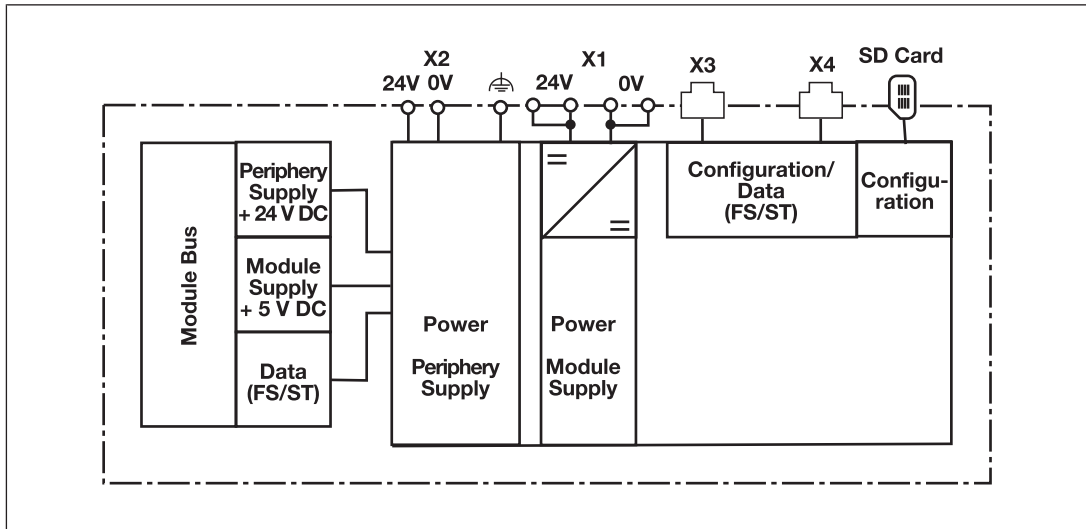

4.2 Control system

The head module is a programmable logic controller (PLC), which can be used in safety-related and non-safety-related applications. The control system has memory areas for the operating system, the data and the device project with the user program.

The head module has a non-volatile memory for the non-volatile variables.

User programs can be created in IEC 61131 programming and/or Multi programming.

For safety-related applications, the processor section is designed with multi-channel diversity.

The control system communicates with the input and output modules via the local module bus and with the decentralised input and output modules via SafetyNET p or for non-safety-related applications as PROFINET IO-DEVICE. LEDs provide information on the status of the control system and indicate any errors.



NOTICE

The controller has the system section with Ethernet/IP Adapter as well as the PROFINET IO DEVICE system section. You can recognise this by the fact that the controller has a common status LED for PROFINET and Ethernet/IP. The status LED is labelled with "BF" for PROFINET and "NS" for Ethernet/IP.

Please note:

You can only use one of the two system sections on the head module; i.e. you can use the head module either as an Ethernet/IP Adapter in Ethernet/IP or as a PROFINET IO device in PROFINET.

4.3 Supply voltage

4.3.1 Function description

The product provides the module supply and periphery supply for the modules on the module bus:

▶ Module supply

Supply voltage for subsequent module (right-hand side)

▶ Periphery supply

Supply voltage for sensors, actuators and test pulses

The periphery supply is monitored for undervoltage and overvoltage. The periphery supply does not switch off automatically if levels drop below the limit values. However, the red LED flashes and a message is entered in the diagnostic log.

– Monitored lower voltage value: 16.8 V

– Monitored upper voltage value: 32 V

The maximum time between two voltage measurements is 100 ms.

The maximum time that can elapse between the first time a value exceeds or falls below a voltage value and the reaction of the head module is 100 ms + cycle time of the FS module bus.

When the supply voltage is fed in separately, the module supply and periphery supply are galvanically isolated. If galvanic isolation is not required, a common power supply may be used for the periphery supply and module supply.

4.3.2 Current load capacity

Ensure you comply with the current load capacity of the module and periphery supply (see [Technical Details \[39\]](#)). If the current load is higher, an additional supply voltage module is required to refresh the module supply and periphery supply.

▶ Module supply

The current load is the total current consumption of all the electronic and compact modules.

The module supply does not automatically switch off if values exceed or drop below their limits. However, the "5 V" LED will light and a message will be entered in the diagnostic list.

▶ Periphery supply

The current load is the total current consumption of the sensors, actuators and test pulses supplied via the input/output modules.

The periphery supply does not automatically switch off if values exceed or drop below their limits. However, the "24 V" LED will light and a message will be entered in the diagnostic list.

Please refer to the derating diagrams.

PSSu H PLC1 FS SN SD: Derating diagram for periphery supply: Temperature T dependent on load current I

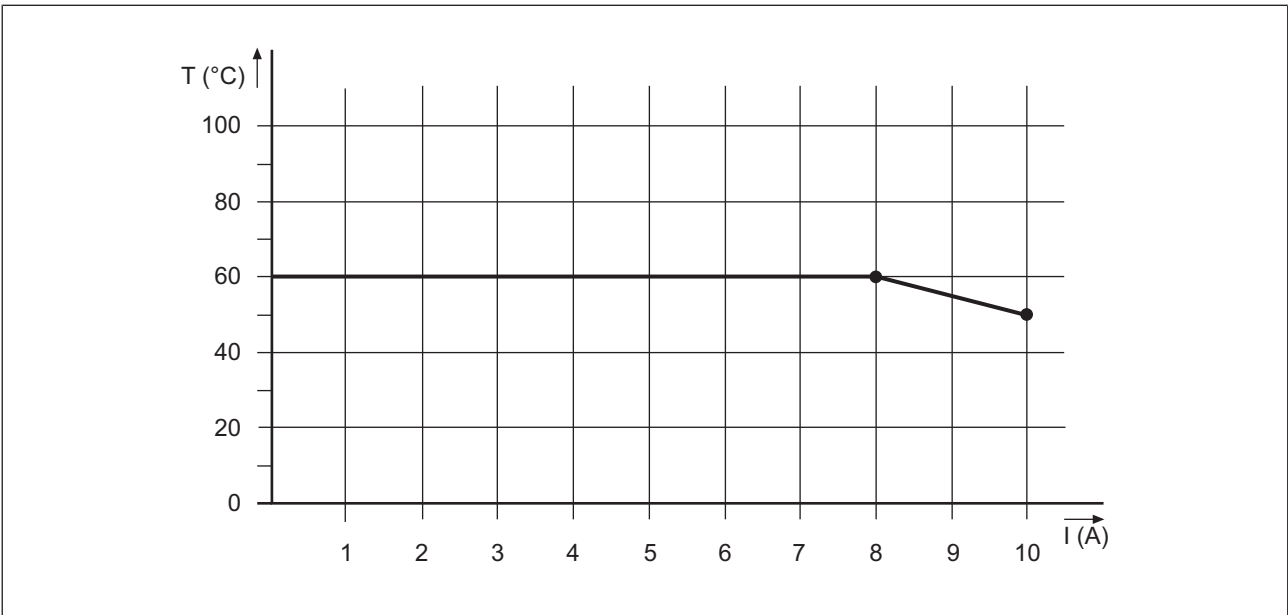

PSSu H PLC1 FS SN SD(-T)(-R): Derating diagram for periphery supply: Permitted ambient temperature T dependent on load current I

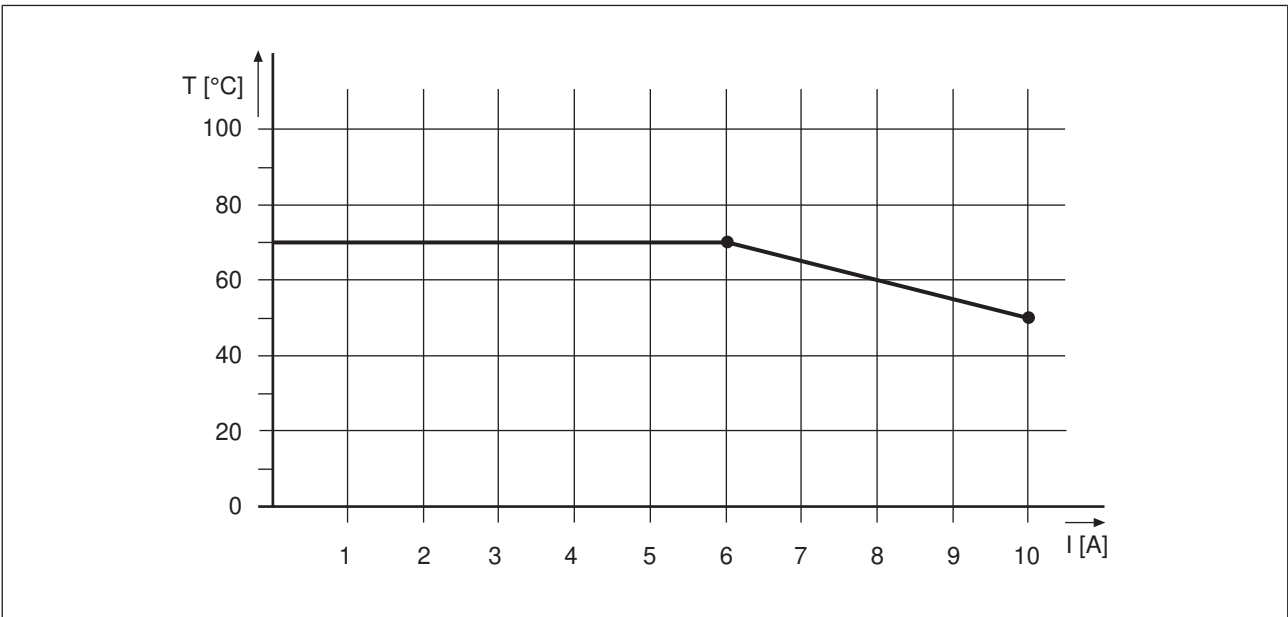

PSSu H PLC1 FS SN SD(-T)(-R): Derating diagram for infeed for module supply: Permitted ambient temperature T dependent on load current I

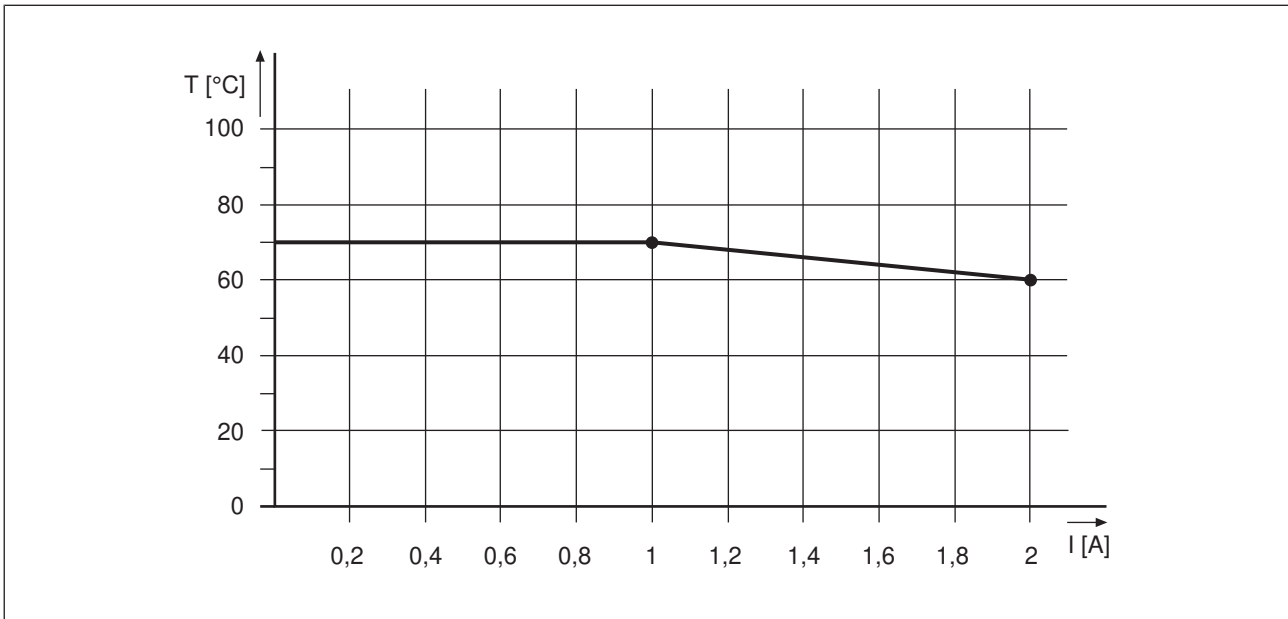

4.4 Integrated protection mechanisms

The module has the following protection mechanisms:

- ▶ Multi-channel diverse processor section
- ▶ Cyclical self tests
- ▶ Potentially isolated **SafetyNET p** interface
- ▶ Infeed for module supply
 - Polarity protection
 - Voltage monitoring
 - Transient voltage limitation
 - 20 ms voltage buffer if the supply voltage is interrupted
- ▶ Module supply
 - Short circuit-proof
- ▶ Periphery supply
 - Voltage monitoring (exceeding upper/lower limit)

4.5 SD card

The SD card has the following functions:

- ▶ The SD card is used to store the naming data and the device project; see PSS 4000 System Description.
- ▶ The SD card is part of the safety concept on PSS 4000. If the SD card is missing or has been swapped, the next time the PSSu system is booted it will be unable to achieve the operating status "PSSu System in RUN condition without error". The SD card has a locking mechanism, which protects it from being removed from the card holder unintentionally. The SD card can also be sealed to protect it from manipulation, whether accidental or intentional.

Sealing the SD card for additional protection:

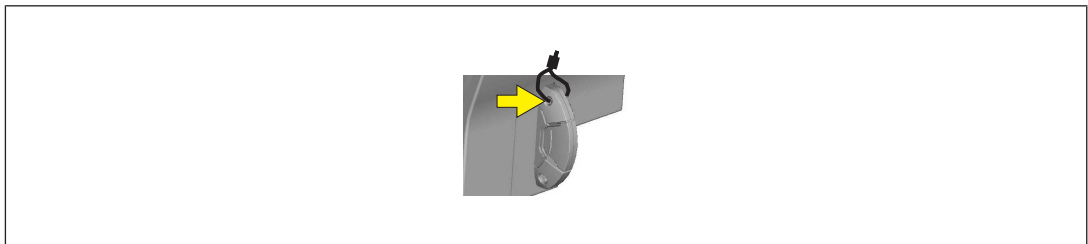

NOTICE

Damage to files on the SD card

Files may be damaged if the card is removed from the device or the power to the device is switched off as the SD card is being written.

Remove the SD card only in recovery mode or in switched-off state.

4.6 Reset button

The "Reset" pushbutton on the head module has various functions:

- ▶ Perform a warm reset for the PSSu system.
The reset pushbutton can be used to perform a warm reset for the PSSu system.
- ▶ Transfer the naming data and/or device project from the SD card (deliberate operator action to transfer the naming data and/or device project from the SD card to the device memory).
- ▶ Perform recovery mode.



INFORMATION

The warm reset and the recovery mode and transfer of the naming data and/or device project are described in the "PSS 4000 System Description". This is also where the general effects on the PSSu system are described in detail.

4.7 SafetyNET p

4.7.1 Connection to SafetyNET p

Functions

- ▶ The SafetyNET p interface enables safety-related and non-safety-related data transfer between the PSSu system and other network subscribers.
- ▶ The head module receives signals from other network subscribers; it processes these signals in the user program and passes them on to the connected input/output modules.
- ▶ The head module receives signals from the connected input/output modules; it processes these signals in the user program and passes them on to the other network subscribers.
- ▶ If a fault occurs, the module switches the connected failsafe outputs to a safe condition.

MAC address

- ▶ The MAC address is a factory-set default. It can be found on the labelling strip on the front of the module.



INFORMATION

Further information on SafetyNET p can be found in the "PSS 4000 System Description".

4.8 External communication

For non-safety-related applications the following IP connections are supported:

- ▶ Modbus/TCP
- ▶ Raw UDP
- ▶ Raw TCP

For non-safety-related applications the following fieldbuses are supported:

- ▶ PROFINET
- ▶ EtherNet/IP

Detailed information is available in the "System description PSS 4000".

5 Installation

5.1 General installation guidelines

Please also refer to the PSSuniversal Installation Manual.

The description below assumes that the mounting rail is already installed.



NOTICE

Damage due to electrostatic discharge!

Electrostatic discharge can damage components. Ensure against discharge before touching the product, e.g. by touching an earthed, conductive surface or by wearing an earthed armband.

5.2 Dimensions

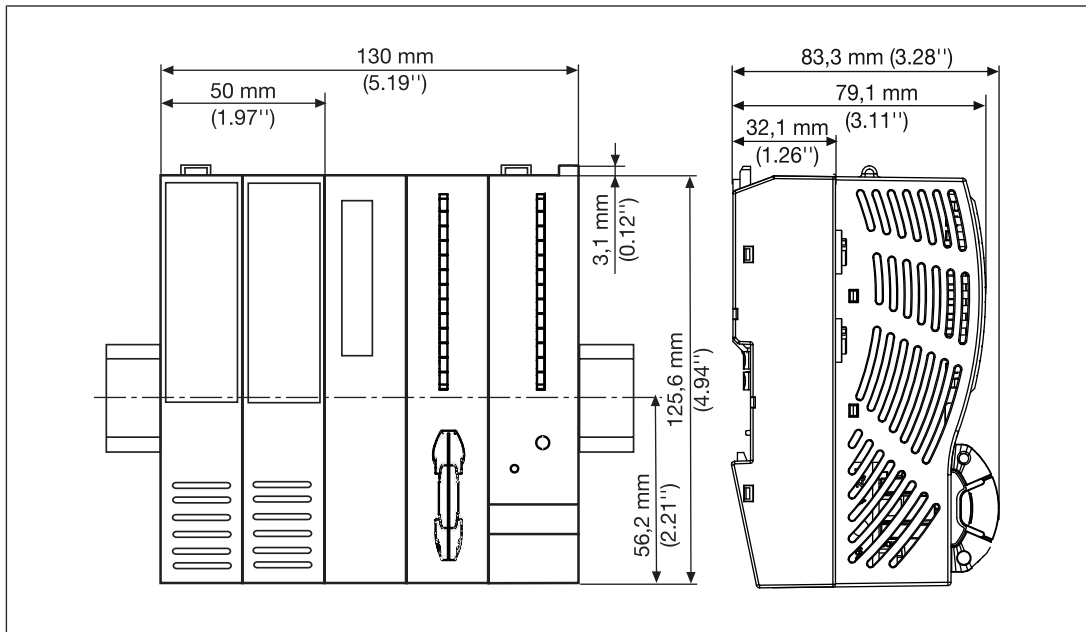

5.3 Installing the head module

Prerequisite:

- ▶ The mounting rail must be installed.

Please note:

- ▶ All contacts should be protected from contamination.

Procedure:

- ▶ Install an end bracket to the left of the head module or leave enough space for one.
- ▶ Slot the groove on the head module on to the mounting rail from below [1].
- ▶ Push the head module back as far as it will go [2].
- ▶ Make sure that the locking mechanisms [3] are pushed downwards, connecting the module firmly to the mounting rail.

Schematic representation:

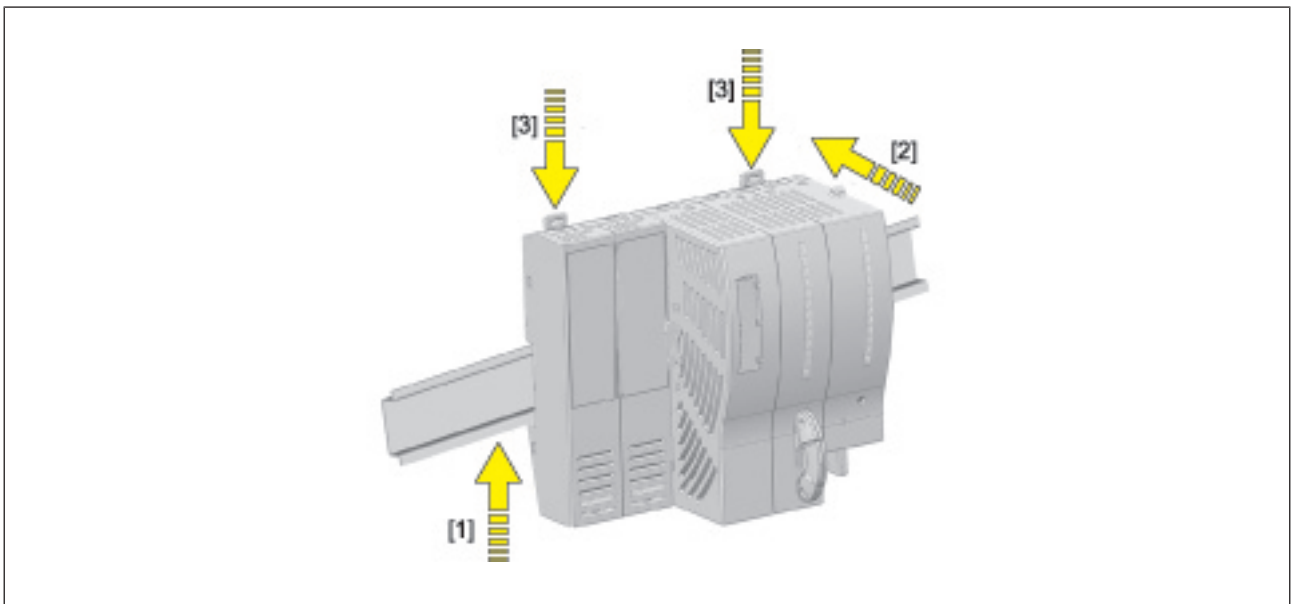

6 Interface assignment

Further information on the Ethernet interface can be found in the system description PSS 4000.

Assignment of the interfaces on head modules with an RJ45 female connector

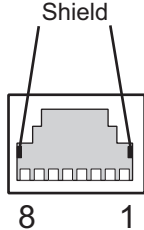
SafetyNET p	Assignment	
RJ45 female connector	1: TD+ 2: TD- 3: RD+ 4: n.c. 5: n.c. 6: RD- 7: n.c. 8: n.c.	

► n.c. = not connected

Assignment of the interfaces on head modules with an M12 female connector

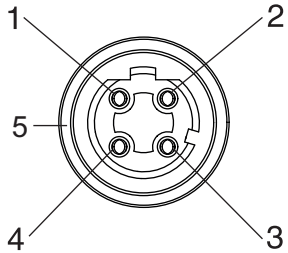
SafetyNET p	Assignment	
4-pin M12 female connector D-coded	1: TD+ 2: RD+ 3: TD- 4 RD- 5: Connection to functional earth on the connector housing	

7 Wiring

7.1 General wiring guidelines

Please note:

- ▶ The requirements for the supply voltages can be found in the chapter entitled [Technical details](#) [39].
- ▶ Protective separation must be ensured for the external power supplies that generate the supply voltages. Failure to do so could result in electric shock.
- ▶ The external power supplies for generating the supply voltages (periphery supply and module supply) must meet the regulations for extra low voltages with protective electrical separation (SELV, PELV). Failure to do so could result in electric shock. A device with a basic insulation that has a supply voltage of over 50 VAC or 120 VDC must not be connected in parallel to the module supply.
- ▶ The external power supplies must comply with the current applicable standard EN 62368-1 or EN 61010-2-201.
- ▶ The maximum current load for the periphery supply on the module bus is 10 A. Please refer to the derating diagram in the chapter entitled "Function Description".
- ▶ Earth the 0 V supply on the periphery supply or monitor each supply group for earth faults.
- ▶ The connection of the 0 V supply to the central earth bar or earth fault monitor must be in accordance with relevant national regulations (e.g. EN 60204-1, NFPA 79:17-7, NEC: Article 250).
- ▶ Details of the minimum range for cable cross sections on connection terminals can be found under [Technical details](#) [39].
- ▶ Use copper wiring.

7.2 Terminal configuration

Module supply	Terminal configuration		X1
4-pin female connector	24V	+24 V infeed for module supply	
	0V	0 V infeed for module supply	

Periphery supply	Terminal configuration		X2
4-pin female connector	24V:	+24 V infeed for periphery supply	
	0V	0 V infeed for periphery supply	
		Functional earth	

7.3 Connecting the module

Separate power supplies for module supply and periphery supply:

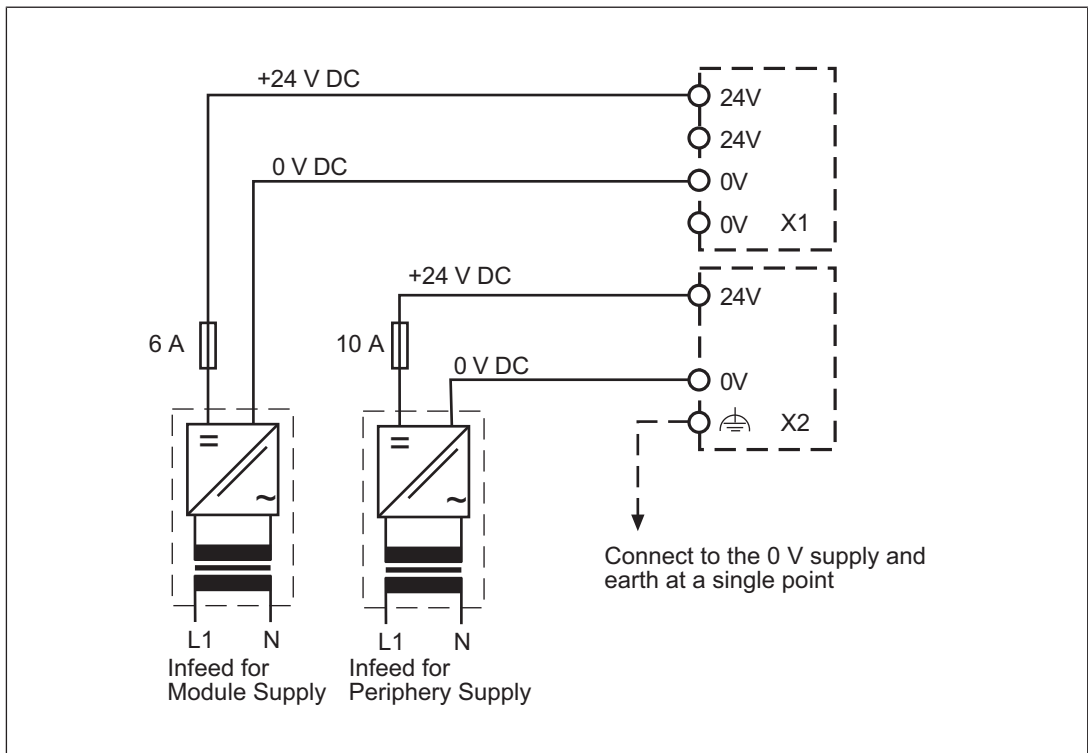

Common power supply for module supply and periphery supply:

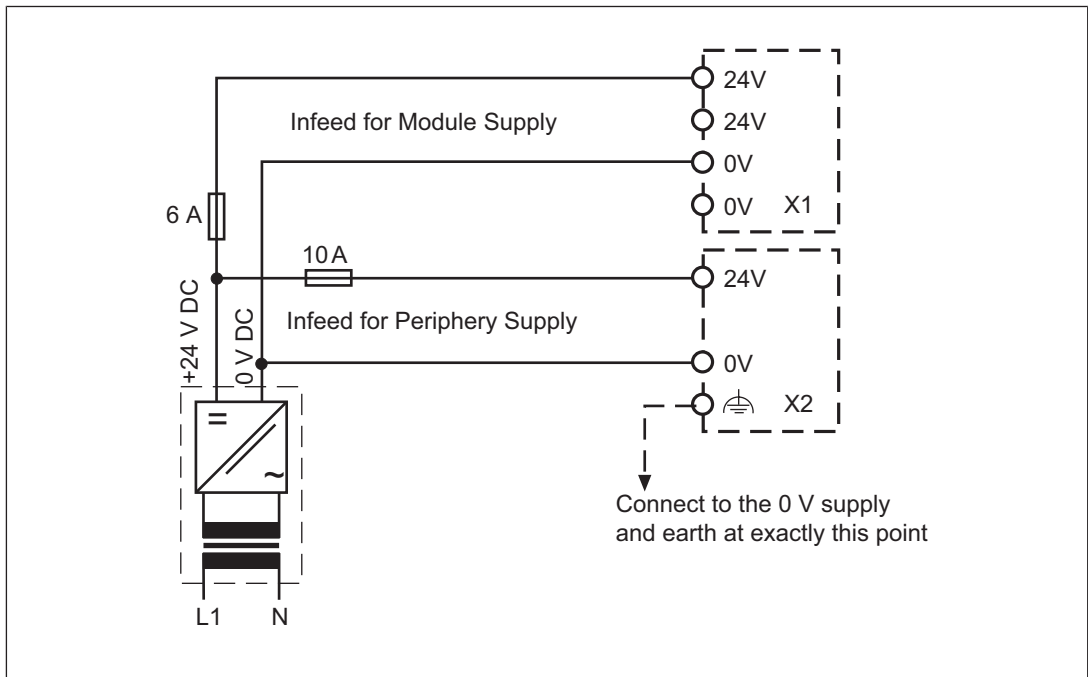

8 Operation

8.1 Messages

The PSSu system provides many options for diagnostics, fault detection and communication with other control systems.

Diagnostics for the PSSu system can be run via the

- ▶ LEDs on the head module,
- ▶ Diagnostic table and diagnostic log.

All errors and faults detected by the electronic or compact modules in a PSSu system are signalled to the head module and entered in the diagnostic table and diagnostic log. You can read the head module's diagnostic table and diagnostic log, e.g. using the PAS4000 or the combination of OPC Server and PSS 4000 Diag Control.



8.2 Display elements

The head module contains a number of status LEDs, which provide information on the status of various system sections.

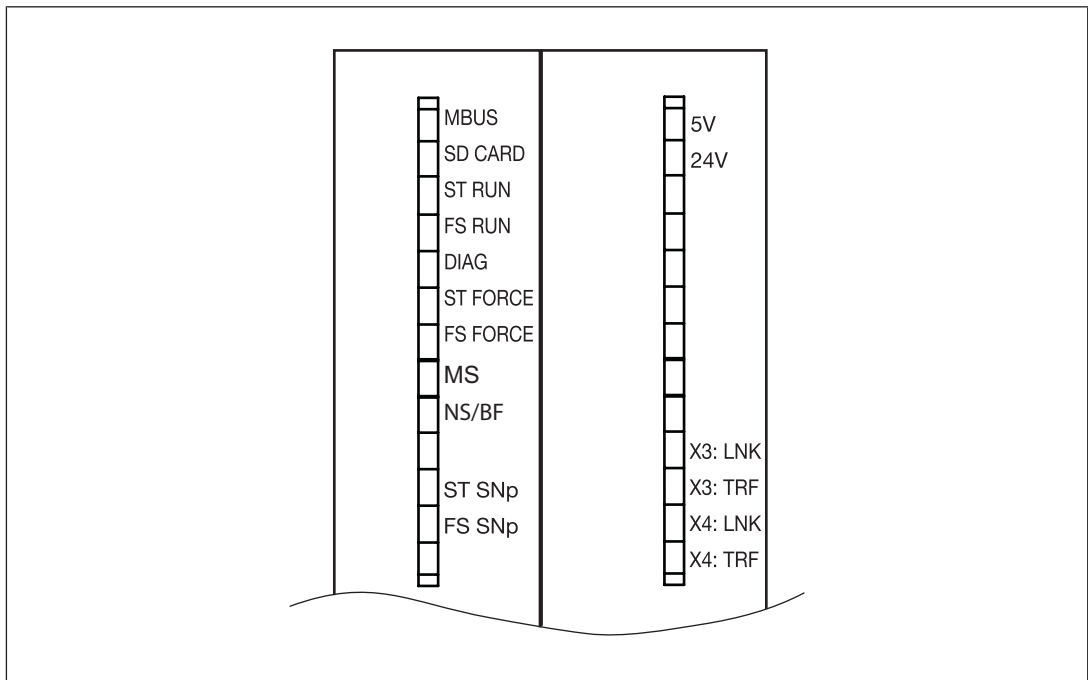
LEDs on the PSSu H PLC1 FS SN SD:







Legend

-  LED on
-  LED flashes
-  LED off







8.2.1 MBUS

The "MBUS" LED indicates the status of the FS and ST module bus.

Colour	Status	Meaning
- - -		No modules are configured and no modules are available.
Green		FS and ST module bus are operating without error
Red		Operating state "Safe state of all FS outputs on the PSSu system" or Unable to locate at least one module (e.g. a module has been removed during operation, set/actual hardware registry does not match)
		Operating state "FS module bus in STOP state with error: major FS error"





8.2.2 SD CARD

The LED indicates the status of the SD card and is used for device identification.

Colour	Status	Meaning
- - -		Supply voltage for module supply is missing
Red		<ul style="list-style-type: none"> ▶ SD card is missing or ▶ SD card not recognised or ▶ SD card defective or ▶ Recovery mode: For some reason, the file system of the SD card could not reconstruct a consistent state.
		<ul style="list-style-type: none"> ▶ "Bind device projects to devices" function: <ul style="list-style-type: none"> – The device does not have the device key that matches the device project. or – The device project does not have the project key that matches the device. and/or ▶ "Bind device projects to SD cards" function: <ul style="list-style-type: none"> The device project is bound to an SD card, but this SD card is not inserted in the device.
Green		Naming data and device project on the device and SD card match
		<ul style="list-style-type: none"> ▶ Product type on the SD card does not match the product type of the device/head module or ▶ No device project on the SD card or ▶ Recovery mode: The file system of the SD card is in a consistent state and the SD card can be removed.
Green-red		Naming data and device project on the device and SD card do not match
Orange		<p>Device identification activated by user</p> <ul style="list-style-type: none"> ▶ Identification as PSS 4000 device in SafetyNET p (PAS4000) or ▶ Identification as PROFINET IO Device in PROFINET (engineering tool for PROFINET)





8.2.3 ST RUN

The "ST RUN" LED indicates the status of the ST resource.

Colour	Status	Meaning
- - -		None of the tasks on the ST resource are started or no tasks are configured.
Green		Operating state "ST resource in RUN state without error": The ST resource tasks are running without error. The project is licensed.
		Operating state "ST resource in RUN state with error": - Task in TERMINATED state or - Task in STOP state At least one ST resource task is not running. The project is licensed.
Orange		Operating state "ST resource in RUN state without error": The ST resource tasks are running without error. The project is unlicensed.
		Operating state "ST resource in RUN state with error": - Task in TERMINATED state or - Task in STOP state At least one ST resource task is not running. The project is unlicensed.







8.2.4 FS RUN

The "FS RUN" LED indicates the status of the FS resource.

Colour	Status	Meaning
- - -		None of the tasks on the FS resource are started or no tasks are configured.
Green		Operating state "FS resource in RUN state without error": The FS resource tasks are running without error. The project is licensed.
		Operating state "FS resource in RUN state with error": - Task in TERMINATED state or - Task in STOP state At least one FS resource task is not running. The project is licensed.
Orange		Operating state "FS resource in RUN state without error": The FS resource tasks are running without error. The project is unlicensed.
		Operating state "FS resource in RUN state with error": - Task in TERMINATED state or - Task in STOP state At least one FS resource task is not running. The project is unlicensed.



8.2.5 DIAG

The "DIAG" LED indicates whether there is a fault in a system section. Precise evaluation can be made via the diagnostic list.

Colour	Status	Meaning
- - -		No system section is started, module supply is missing.
Green		No message of "Error" or "Warning" severity is present for the device.
		Device diagnostic list and device diagnostic log are being prepared
Red		A message of "Error" severity is present for at least one system section (see diagnostic table).
		<ul style="list-style-type: none"> ▶ A major FS error is present for at least one FS system section (see diagnostic list). or <ul style="list-style-type: none"> ▶ The boot process was stopped because an internal error occurred. Diagnostics are not available. The reset pushbutton has no function.
Orange		A message of at least "Warning" severity is present for the device (see diagnostic list).
Red - green		Start of "deliberate operator action" (function of reset button)

8.2.6 ST FORCE



The "ST FORCE" LED indicates the status of the online changes on the ST resource.

Colour	Status	Meaning
- - -		No online change is active on the ST resource. Note: Forcing on the ST resource is not supported.
Yellow		At least one online change is active on the ST resource.

8.2.7





FS FORCE

The "FS FORCE" LED indicates the status of forcing and online changes on the FS resource.

Colour	Status	Meaning
- - -		On the FS resource, forcing is inactive and there is no on-line change active
Yellow		On the FS resource, forcing is active and/or there is at least one online change active





8.2.8 MS

The "MS" LED displays the module status in accordance with the EtherNet/IP specification.





Colour	Status	Meaning
- - -		No supply voltage or Device inactive or Device not configured
Green		No message of "Error" or "Warning" severity is present for the device.
Red		A message of "Error" severity is present for at least one system section or a major FS error is present for at least one FS system section (see diagnostic list).
		At least one message of "Warning" severity is present for the device, no message of "Error" severity is present and no invalid data is being downloaded to the scanner.

8.2.9 NS/BF

The "NS" LED displays the network status in accordance with the EtherNet/IP specification.





Colour	Status	Meaning
---		No data traffic or EtherNet/IP not configured or No IP address configured
Green		Network connection is available and EtherNet/IP communication is ok
		No network connection
Red		Connection timeout

The LED "BF" indicates the bus status in accordance with the PROFINET IO specification.

Colour	Status	Meaning
---		The PROFINET IO Device is deactivated; i.e. no virtual PROFINET IO modules are configured.
Green		The PROFINET IO Device is in "Operational" state, data exchange possible
Red		No connection to PROFINET IO Controller
		Connection to PROFINET IO Controller avail- able, no data exchange due to faulty parameter settings





8.2.10 ST SNp

The "ST SNp" LED indicates the status of the non-safety-related system section ST SafetyNET p.

Colour	Status	Meaning
- - -		System section ST SafetyNET p has not been started
Green		Operating state "ST SafetyNET p in RUN state without error"
		Operating state "ST SafetyNET p in RUN state with minor error"
Red		Operating state "ST SafetyNET p in STOP state with error: Major FS+ST error"
		



8.2.11 FS SNp

The "FS SNp" LED indicates the status of the safety-related system section FS SafetyNET p.



Colour	Status	Meaning
- - -		System section FS SafetyNET p has not been started
Green		Operating state "FS SafetyNET p in RUN state without error"
		Operating state "FS SafetyNET p in RUN state with minor error"
Red		Operating state "FS SafetyNET p in STOP state with error: Major FS error"
		Operating state "FS SafetyNET p in STOP state with error: Major FS+ST error"

8.2.12 5V, 24V

The "5 V" LED indicates the status of the module supply.

Colour	Status	Meaning
- - -		No supply voltage for module supply or supply voltage is faulty
Green		Module supply is available



The "24 V" LED indicates the status of the periphery supply.

Colour	Status	Meaning
- - -		No supply voltage for periphery supply or supply voltage is faulty
Green		Periphery supply is available



8.2.13 X3: LNK, X3: TRF, X4: LNK, X4: TRF

These status LEDs are the display elements for the interfaces (X3 and X4). Both interfaces are assigned two LEDs each. Various operating and fault states are displayed via the LEDs.

X3: LNK, X3: LNK

Colour	Status	Meaning
---		No network connection
Green		Network connection is error-free

X3: TRF, X4: TRF

Colour	Status	Meaning
---		No data traffic
Yellow		Data traffic is error-free

9 Technical details Order no. 312070, 314070, 314071

General	312070	314070	314071
Certifications	CE, EAC, KOSHA, TÜV, UKCA, cULus Listed	CE, EAC, TÜV, UKCA, cULus Listed	CE, TÜV, UKCA, cULus Listed
Application range	Standard/failsafe	Standard/failsafe	Standard/failsafe
System sections	312070	314070	314071
ST resource	Yes	Yes	Yes
FS resource	Yes	Yes	Yes
ST module bus PSSu	Yes	Yes	Yes
FS module bus PSSu	Yes	Yes	Yes
ST SNp interface	Yes	Yes	Yes
FS SNp interface	Yes	Yes	Yes
PROFIBUS-DP Slave	No	No	No
PROFINET IO DEVICE	Yes	Yes	Yes
IP connections	Yes	Yes	Yes
EtherNet/IP (TM) adapter	Yes	Yes	Yes
Diagnostic Server	No	No	No
OPC Server	No	No	No
Programming	312070	314070	314071
IEC 61131 programming	Yes	Yes	Yes
Multi programming	Yes	Yes	Yes
Non-volatile variables	Yes	Yes	Yes
Electrical data	312070	314070	314071
Supply voltage			
for	Module supply	Module supply	Module supply
Voltage	24 V	24 V	24 V
Kind	DC	DC	DC
Voltage tolerance	-30 %/+25 %	-30 %/+25 %	-30 %/+25 %
Max. continuous current that the external power supply must provide	1 A	1 A	1 A
Output of external power supply (DC)	16 W	16 W	16 W
Supply voltage			
for	Periphery supply	Periphery supply	Periphery supply
Voltage	24 V	24 V	24 V
Kind	DC	DC	DC
Voltage tolerance	-30 %/+25 %	-30 %/+25 %	-30 %/+25 %
Max. continuous current that the external power supply must provide	10 A	10 A	10 A

Electrical data	312070	314070	314071
Internal supply voltage (module supply)			
Output voltage	int. system	int. system	int. system
Voltage	5 V	5 V	5 V
Kind	DC	DC	DC
Voltage tolerance	-2 %/+3 %	-2 %/+3 %	-2 %/+3 %
Current load capacity	2 A	2 A	2 A
Buffer in the case of supply interruptions in accordance with	EN 61131-2	EN 61131-2	EN 61131-2
Short circuit-proof	Yes	Yes	Yes
CPU	312070	314070	314071
Real-time clock for time and date functions			
Resolution	1 s	1 s	1 s
Deviation	+/- 10s/day	+/- 10s/day	+/- 10s/day
Buffer time	10 days	10 days	10 days
Max. number of FS tasks	9	9	9
Max. number of ST tasks	9	9	9
Min. cycle time of FS tasks	6 ms	6 ms	6 ms
Min. cycle time of ST tasks	2 ms	2 ms	2 ms
Working memory (RAM)	128 MB	128 MB	128 MB
Memory for the user program per resource	4 MB	4 MB	4 MB
Non-volatile FS memory	382 kB	382 kB	382 kB
Non-volatile ST memory	128 kB	128 kB	128 kB
Removable data medium	312070	314070	314071
Type	SD card	SD card	SD card
SafetyNET p interface	312070	314070	314071
Quantity	2	2	2
IP address (automatically off)	169.254.X.Y	169.254.X.Y	169.254.X.Y
Connection	RJ45	RJ45	M12
Transmission rates	100 MBit/s	100 MBit/s	100 MBit/s
Set via	Automatic	Automatic	Automatic
Max. number of ST-Tx and ST-Rx connections	64	64	64
Max. number of FS-Tx and FS-Rx connections	64	64	64
Cycle time (t _{SNp} RTFN)	2 ... 60 000 ms	2 ... 60 000 ms	2 ... 60 000 ms
PROFINET interface	312070	314070	314071
Input	1.440 Byte	1.440 Byte	1.440 Byte
Output	1.440 Byte	1.440 Byte	1.440 Byte

PROFINET interface	312070	314070	314071
Transmission rates	100 MBit/s	100 MBit/s	100 MBit/s
Transmission rate selectable via	Automatic	Automatic	Automatic
Certification	PNO	PNO	PNO
Vendor ID	092Fh	092Fh	092Fh
Connection	RJ45	RJ45	M12
Device type	Slave	Slave	Slave
Cycle time (t_ExtCo)	4 ... 512 ms	4 ... 512 ms	4 ... 512 ms
Modbus/TCP	312070	314070	314071
Cycle time (t_ExtCo)	2 ... 2 000 000 ms	2 ... 2 000 000 ms	2 ... 2 000 000 ms
EtherNet/IP (TM) adapter	312070	314070	314071
Cycle time (tExtCo)	4...655 000 ms	4...655 000 ms	4...655 000 ms
Vendor ID	181	181	181
Product ID	1	1	1
EDS file	00B5000C00010100.eds	00B5000C00010100.eds	00B5000C00010100.eds
Device type	Adapter	Adapter	Adapter
Cycle time (RPI)	4...655 000 ms	4...655 000 ms	4...655 000 ms
Maximum data length	508 Byte	508 Byte	508 Byte
Maximum number of I/O connections	1	1	1
Raw UDP	312070	314070	314071
Memory size	8 Kbyte	8 Kbyte	8 Kbyte
Cycle time (t_ExtCo)	2 ... 2 000 000 ms	2 ... 2 000 000 ms	2 ... 2 000 000 ms
Environmental data	312070	314070	314071
Climatic suitability	EN 60068-2-1, EN 60068-2-14, EN 60068-2-2, EN 60068-2-30, EN 60068-2-78	EN 60068-2-1, EN 60068-2-14, EN 60068-2-2, EN 60068-2-30, EN 60068-2-78	EN 60068-2-1, EN 60068-2-14, EN 60068-2-2, EN 60068-2-30, EN 60068-2-78
Ambient temperature			
Temperature range	0 - 60 °C	-40 - 70 °C	-40 - 70 °C
Storage temperature			
Temperature range	-40 - 70 °C	-40 - 70 °C	-40 - 70 °C
Climatic suitability			
in accordance with the standard	EN 60068-2-78	EN 60068-2-78	EN 60068-2-78
Humidity	93 % r. h. at 40 °C	93 % r. h. at 40 °C	93 % r. h. at 40 °C
Condensation during operation	Not permitted	EN 60068-2-30, short-term	EN 60068-2-30, short-term
Max. operating height above SL	2000 m	5000 m	5000 m
EMC	EN 12015, EN 12016, EN 61000-6-2, EN 61000-6-4, EN 61131-2 (Zone B)	EN 12015, EN 12016, EN 61000-6-2, EN 61000-6-4, EN 61131-2 (Zone B)	EN 61000-6-2, EN 61000-6-4, EN 61131-2 (Zone B)

Environmental data	312070	314070	314071
Vibration			
in accordance with the standard	EN 60068-2-6	EN 60068-2-6	EN 60068-2-6
Frequency	8,4 - 150 Hz	8,4 - 150 Hz	8,4 - 150 Hz
Acceleration	10 m/s²	10 m/s²	10 m/s²
Broadband noise			
in accordance with the standard	–	EN 60068-2-64	EN 60068-2-64
Frequency	–	5 - 500 Hz	5 - 500 Hz
Acceleration	–	19 m/s² eff.	19 m/s² eff.
Shock stress			
in accordance with the standard	EN 60068-2-27	EN 60068-2-27	EN 60068-2-27
Number of shocks	6	6	6
Acceleration	150 m/s²	150 m/s²	150 m/s²
Duration	11 ms	11 ms	11 ms
Airgap creepage			
in accordance with the standard	EN 61131-2	EN 61131-2	EN 61131-2
Overvoltage category	II	II	II
Pollution degree	2	2	2
Protection type			
Housing	IP20	IP20	IP20
Mounting area (e.g. control cabinet)	IP54	IP54	IP54
Potential isolation			
Potential isolation between	Periphery supply and module supply	Periphery supply and module supply	Periphery supply and module supply
Type of potential isolation	Functional insulation	Functional insulation	Functional insulation
Rated surge voltage in operating heights up to max. 2000 m	2000 V	2000 V	2000 V
Rated surge voltage in operating heights up to max. 5000 m	–	1500 V	1500 V
Potential isolation between	Periphery supply and system voltage	Periphery supply and system voltage	Periphery supply and system voltage
Type of potential isolation	Functional insulation	Functional insulation	Functional insulation
Rated surge voltage in operating heights up to max. 2000 m	2000 V	2000 V	2000 V
Rated surge voltage in operating heights up to max. 5000 m	–	1500 V	1500 V
Mechanical data			
Material	PC	PC	PC
Bottom	PC	PC	PC

Mechanical data	312070	314070	314071
Connection type	Spring-loaded terminal, screw terminal	Spring-loaded terminal, screw terminal	Spring-loaded terminal, screw terminal
Mounting type	plug-in	plug-in	plug-in
Conductor cross section with screw terminals			
1 core flexible	0,25 - 2,5 mm², 24 - 12 AWG	0,25 - 2,5 mm², 24 - 12 AWG	0,25 - 2,5 mm², 24 - 12 AWG
2 core with the same cross section, flexible with crimp connectors, no plastic sleeve	0,25 - 1 mm², 24 - 16 AWG	0,25 - 1 mm², 24 - 16 AWG	0,25 - 1 mm², 24 - 16 AWG
2 core with the same cross section, flexible without crimp connectors or with TWIN crimp connectors	0,2 - 1,5 mm², 24 - 16 AWG	0,2 - 1,5 mm², 24 - 16 AWG	0,2 - 1,5 mm², 24 - 16 AWG
Torque setting with screw terminals	0,5 Nm	0,5 Nm	0,5 Nm
Conductor cross section with spring-loaded terminals: Flexible with/without crimp connector	0,2 - 2,5 mm², 24 - 12 AWG	0,2 - 2,5 mm², 24 - 12 AWG	0,2 - 2,5 mm², 24 - 12 AWG
Stripping length with spring-loaded terminals	9 mm	9 mm	9 mm
Dimensions			
Height	125,6 mm	125,6 mm	125,6 mm
Width	130 mm	130 mm	130 mm
Depth	83,7 mm	83,7 mm	83,7 mm
Weight	365 g	378 g	370 g

Where standards are undated, the 2022-01 latest editions shall apply.

10 Technical details Order no. 315070, 315071

General	315070	315071
Certifications	CE, EAC, TÜV, UKCA	CE, EAC, TÜV, UKCA
Application range	Standard/failsafe	Standard/failsafe
System sections	315070	315071
ST resource	Yes	Yes
FS resource	Yes	Yes
ST module bus PSSu	Yes	Yes
FS module bus PSSu	Yes	Yes
ST SNp interface	Yes	Yes
FS SNp interface	Yes	Yes
PROFIBUS-DP Slave	No	No
PROFINET IO DEVICE	Yes	Yes
IP connections	Yes	Yes
EtherNet/IP (TM) adapter	Yes	Yes
Diagnostic Server	No	No
OPC Server	No	No
Programming	315070	315071
IEC 61131 programming	Yes	Yes
Multi programming	Yes	Yes
Non-volatile variables	Yes	Yes
Electrical data	315070	315071
Supply voltage		
for	Module supply	Module supply
Voltage	24 V	24 V
Kind	DC	DC
Voltage tolerance	-30 %/+25 %	-30 %/+25 %
Max. continuous current that the external power supply must provide	1 A	1 A
Output of external power supply (DC)	16 W	16 W
Supply voltage		
for	Periphery supply	Periphery supply
Voltage	24 V	24 V
Kind	DC	DC
Voltage tolerance	-30 %/+25 %	-30 %/+25 %
Max. continuous current that the external power supply must provide	10 A	10 A

Electrical data	315070	315071
Internal supply voltage (module supply)		
Output voltage	int. system	int. system
Voltage	5 V	5 V
Kind	DC	DC
Voltage tolerance	-2 %/+3 %	-2 %/+3 %
Current load capacity	2 A	2 A
Buffer in the case of supply interruptions in accordance with	EN 50155	EN 50155
Short circuit-proof	Yes	Yes
CPU	315070	315071
Real-time clock for time and date functions		
Resolution	1 s	1 s
Deviation	+/- 10s/day	+/- 10s/day
Buffer time	10 days	10 days
Max. number of FS tasks	9	9
Max. number of ST tasks	9	9
Max. number of variables with elementary data types on the FS resource	10.000	10.000
Max. number of variables with elementary data types on the ST resource	10.000	10.000
Min. cycle time of FS tasks	6 ms	6 ms
Min. cycle time of ST tasks	2 ms	2 ms
Working memory (RAM)	128 MB	128 MB
Memory for the user program per resource	4 MB	4 MB
Non-volatile FS memory	382 kB	382 kB
Non-volatile ST memory	128 kB	128 kB
Removable data medium	315070	315071
Type	SD card	SD card
SafetyNET p interface	315070	315071
Quantity	2	2
IP address (automatically off)	169.254.X.Y	169.254.X.Y
Connection	RJ45	M12
Transmission rates	100 MBit/s	100 MBit/s
Set via	Automatic	Automatic
Max. number of ST-Tx and ST-Rx connections	64	64
Max. number of FS-Tx and FS-Rx connections	64	64
Cycle time (t _{SNp} RTFN)	2 ... 60 000 ms	2 ... 60 000 ms
Max. number of variables with elementary ST data types	5000	5000

SafetyNET p interface	315070	315071
Max. number of variables with elementary FS data types	4000	4000
PROFINET interface	315070	315071
Input	1.440 Byte	1.440 Byte
Output	1.440 Byte	1.440 Byte
Transmission rates	100 MBit/s	100 MBit/s
Transmission rate selectable via	Automatic	Automatic
Certification	PNO	PNO
Vendor ID	092Fh	092Fh
Connection	RJ45	M12
Device type	Slave	Slave
Cycle time (t_ExtCo)	4 ... 512 ms	4 ... 512 ms
Modbus/TCP	315070	315071
Cycle time (t_ExtCo)	2 ... 2 000 000 ms	2 ... 2 000 000 ms
EtherNet/IP (TM) adapter	315070	315071
Cycle time (tExtCo)	4...655 000 ms	4...655 000 ms
Vendor ID	181	181
Product ID	1	1
EDS file	00B5000C00010100.eds	00B5000C00010100.eds
Device type	Adapter	Adapter
Cycle time (RPI)	4...655 000 ms	4...655 000 ms
Maximum data length	508 Byte	508 Byte
Maximum number of I/O connections	1	1
Raw UDP	315070	315071
Memory size	8 Kbyte	8 Kbyte
Cycle time (t_ExtCo)	2 ... 2 000 000 ms	2 ... 2 000 000 ms
Environmental data	315070	315071
Application site		
in accordance with the standard	EN 50125-3	EN 50125-3
Application site	Track area (1 m - 3 m)	Track area (1 m - 3 m)
in accordance with the standard	EN 61373	EN 61373
Application site	Category 1, Class A + B	Category 1, Class A + B
Climatic suitability	EN 50125-1, EN 50125-3, EN 50155, EN 60068-2-1, EN 60068-2-14, EN 60068-2-2	EN 50125-1, EN 50125-3, EN 50155, EN 60068-2-1, EN 60068-2-14, EN 60068-2-2
Ambient temperature		
in accordance with the standard	EN 50155	EN 50155
Temperature range	-40 - 70 °C	-40 - 70 °C
in accordance with the standard	EN 50125-1	EN 50125-1
Temperature range	-40 ... +70 °C	-40 ... +70 °C
in accordance with the standard	EN 50125-3	EN 50125-3
Temperature range	-40 ... +70 °C	-40 ... +70 °C
Storage temperature		
Temperature range	-40 - 70 °C	-40 - 70 °C

Environmental data	315070	315071
Climatic suitability		
in accordance with the standard	EN 60068-2-78	EN 60068-2-78
Humidity	97 % r. h. at 40 °C	97 % r. h. at 40 °C
Condensation during operation	EN 50155, EN 60068-2-30, short-term	EN 50155, EN 60068-2-30, short-term
Max. operating height above SL	2000 m	2000 m
EMC	EN 50121-3-2, EN 50121-4, EN 61000-6-2, EN 61000-6-4	EN 50121-3-2, EN 50121-4, EN 61000-6-2, EN 61000-6-4
Broadband noise		
in accordance with the standard	EN 61373	EN 61373
Frequency	5 ... 150 Hz	5 ... 150 Hz
Acceleration	5,72 m/s² eff.	5,72 m/s² eff.
in accordance with the standard	EN 50125-3	EN 50125-3
Frequency	5 - 2.000 Hz	5 - 2.000 Hz
Acceleration	2,3 m/s² eff.	2,3 m/s² eff.
Shock stress		
in accordance with the standard	EN 50125-3	EN 50125-3
Number of shocks	6	6
Acceleration	20 m/s²	20 m/s²
Duration	11 ms	11 ms
in accordance with the standard	EN 61373	EN 61373
Number of shocks	6	6
Acceleration	50 m/s²	50 m/s²
Duration	30 ms	30 ms
Supply interruptions		
in accordance with the standard	EN 50155	EN 50155
Class	S2, C1, C2	S2, C1, C2
Airgap creepage		
in accordance with the standard	EN 50124-1	EN 50124-1
Overvoltage category	OV2	OV2
Pollution degree	PD2	PD2
Protection type		
in accordance with the standard	EN 60529	EN 60529
Mounting area	IP51	IP51
Housing	IP20	IP20
Terminals	IP20	IP20
Potential isolation	315070	315071
Potential isolation between	Periphery supply and module supply	Periphery supply and module supply
Type of potential isolation	Functional insulation	Functional insulation
Rated surge voltage	2000 V	2000 V
Potential isolation between	Periphery supply and system voltage	Periphery supply and system voltage
Type of potential isolation	Functional insulation	Functional insulation
Rated surge voltage	2000 V	2000 V

Mechanical data	315070	315071
Material		
Bottom	PC	PC
Connection type	Spring-loaded terminal, screw terminal	Spring-loaded terminal, screw terminal
Mounting type	plug-in	plug-in
Conductor cross section with screw terminals		
1 core flexible	0,25 - 2,5 mm², 24 - 12 AWG	0,25 - 2,5 mm², 24 - 12 AWG
2 core with the same cross section, flexible with crimp connectors, no plastic sleeve	0,25 - 1 mm², 24 - 16 AWG	0,25 - 1 mm², 24 - 16 AWG
2 core with the same cross section, flexible without crimp connectors or with TWIN crimp connectors	0,2 - 1,5 mm², 24 - 16 AWG	0,2 - 1,5 mm², 24 - 16 AWG
Torque setting with screw terminals	0,5 Nm	0,5 Nm
Conductor cross section with spring-loaded terminals: Flexible with/without crimp connector	0,2 - 2,5 mm², 24 - 12 AWG	0,2 - 2,5 mm², 24 - 12 AWG
Stripping length with spring-loaded terminals	9 mm	9 mm
Dimensions		
Height	125,6 mm	125,6 mm
Width	130 mm	130 mm
Depth	83,7 mm	83,7 mm
Weight	350 g	370 g

Where standards are undated, the 2022-01 latest editions shall apply.

11 Safety characteristic data



NOTICE

You must comply with the safety characteristic data in order to achieve the required safety level for your plant/machine.

Order no.	EN ISO 13849-1: 2015 PL	EN ISO 13849-1: 2015 Category	EN 62061 SIL CL	EN 62061 PFH _D [1/h]	IEC 61511 SIL	IEC 61511 PFD	EN ISO 13849-1: 2015 T _M [year]
312 070, 314 070, 315 070	PL e	Cat. 4	SIL CL 3	4,14E-09	SIL 3	3,51E-05	20
314 071, 315 071	PL e	Cat. 4	SIL CL 3	4,18E-09	SIL 3	3,54E-05	20

If the module is operated at an ambient temperature above 60° C, the values stated in the table for PFH_D and PFD will need to be doubled when a safety function is calculated.

All the units used within a safety function must be considered when calculating the safety characteristic data.



INFORMATION

A safety function's SIL/PL values are **not** identical to the SIL/PL values of the units that are used and may be different. We recommend that you use the PAScal software tool to calculate the safety function's SIL/PL values.

12 Supplementary data

12.1 Permitted operating height

The values stated in the technical details apply to the use of the device in operating heights up to max. 2000 m above SL. When used at higher levels, restrictions of the ambient temperature (standard IEC 61131-2) must be taken into account.

Operating height above SL [m]	Multiplication factors for the devices' ambient temperature
0 ... 2000	1.0
3000	0.9
4000	0.8
5000	0.7

13 Order reference

13.1 Product

Product type	Features	Order no.
PSSu H PLC1 FS SN SD	Head module with SafetyNET p, base type	312070
PSSu H PLC1 FS SN SD-T	Head module with SafetyNET p, T-type	314070
PSSu H PLC1 FS SN SD M12-T	Head module with SafetyNET p, M12 female connector T-type	314071
PSSu H PLC1 FS SN SD-R	Head module with SafetyNET p, R-type	315070
PSSu H PLC1 FS SN SD M12-R	Head module with SafetyNET p, M12 female connector R-type	315071

13.2 Accessories

Cable

Product type	Features	Order no.
SafetyNET p cable	SafetyNET p cable, standard, 4-core, sold by the metre, minimum purchase 10 m	380000
M12 con., straight, male, 4-pin, D	Connector, M12, 4-pin, D-coded	380316
SafetyNET p connector RJ45s	RJ45 plug-in connector, straight, IP20, 4-pin, Cat5e, AWG 22 (4-core), cable diameter: 6.3 - 6.7 mm	380400
RJ45 Connector	RJ45 plug-in connector, straight, IP20, 8-pin, Cat6a, IDC connection, AWG 22, cable diameter: 5.5 - 8.5 mm	380401
Stripping tool	Assembly tool for SafetyNET p cable	380070

Terminals

Product type	Features	Order no.
PSSu A Con 1/4 S	2 x screw terminals	313110
PSSu A Con 2/8 C	2 x spring-loaded terminals	313111

14 **EC declaration of conformity**

This product/these products meet the requirements of the directive 2006/42/EC on machinery of the European Parliament and of the Council. The complete EC Declaration of Conformity is available on the Internet at www.pilz.com/downloads.

Representative: Pilz GmbH & Co. KG, Felix-Wankel-Str. 2, 73760 Ostfildern, Germany

15 UKCA-Declaration of Conformity

This product(s) complies with following UK legislation: Supply of Machinery (Safety) Regulation 2008.

The complete UKCA Declaration of Conformity is available on the Internet at www.pilz.com/downloads.

Representative: Pilz Automation Technology, Pilz House, Little Colliers Field, Corby, Northamptonshire, NN18 8TJ United Kingdom, eMail: mail@pilz.co.uk

► Support

Technical support is available from Pilz round the clock.

Americas

Brazil

+55 11 97569-2804

Canada

+1 888 315 7459

Mexico

+52 55 5572 1300

USA (toll-free)

+1 877-PILZUSA (745-9872)

Asia

China

+86 400-088-3566

Japan

+81 45 471-2281

South Korea

+82 31 778 3300

Australia and Oceania

Australia

+61 3 95600621

New Zealand

+64 9 6345350

Europe

Austria

+43 1 7986263-444

Belgium, Luxembourg

+32 9 3217570

France

+33 3 88104003

Germany

+49 711 3409-444

Ireland

+353 21 4804983

Italy, Malta

+39 0362 1826711

Scandinavia

+45 74436332

Spain

+34 938497433

Switzerland

+41 62 88979-32

The Netherlands

+31 347 320477

Türkiye

+90 216 5775552

United Kingdom

+44 1536 462203

You can reach our international hotline on:

+49 711 3409-222

support@pilz.com

Pilz develops environmentally-friendly products using ecological materials and energy-saving technologies. Offices and production facilities are ecologically designed, environmentally-aware and energy-saving. So Pilz offers sustainability, plus the security of using energy-efficient products and environmentally-friendly solutions.



CECE[®], CHRE[®], CMSE[®], INDUSTRIAL P[®], Leansafe[®], Myzel[®], PAS4000[®], PASscal[®], PASconfig[®], Pilz[®], PIT[®], PMSprimo[®], PMSprotego[®], PMCiendo[®], PMD[®], PMI[®], PNOZ[®], Primo[®], PSEN[®], PSS[®], PVS[®], SafetyBUS p[®], SafetyNET p[®], THE SPIRIT OF SAFETY[®] are registered and protected trademarks of Pilz GmbH & Co. KG in some countries. We would point out that product features may vary from the details stated in this document, depending on the status at the time of publication and the scope of the equipment. We accept no responsibility for the validity, accuracy and entirety of the text and graphics presented in this information. Please contact our Technical Support if you have any questions.

21939-EN-20, 2023-08 Printed in Germany
© Pilz GmbH & Co. KG, 2019

We are represented internationally. Please refer to our homepage www.pilz.com for further details or contact our headquarters.

Headquarters: Pilz GmbH & Co. KG, Felix-Wankel-Straße 2, 73760 Ostfildern, Germany
Telephone: +49 711 3409-0, E-Mail: info@pilz.com, Internet: www.pilz.com

PILZ
THE SPIRIT OF SAFETY