

**PSSu H IBSe**



Decentralised system PSSuniversal I/O

This document is a translation of the original document.

All rights to this documentation are reserved by Pilz GmbH & Co. KG. Copies may be made for internal purposes.

Suggestions and comments for improving this documentation will be gratefully received.

Pilz<sup>®</sup>, PIT<sup>®</sup>, PMI<sup>®</sup>, PNOZ<sup>®</sup>, Primo<sup>®</sup>, PSEN<sup>®</sup>, PSS<sup>®</sup>, PVIS<sup>®</sup>, SafetyBUS p<sup>®</sup>, SafetyEYE<sup>®</sup>, SafetyNET p<sup>®</sup>, the spirit of safety<sup>®</sup> are registered and protected trademarks of Pilz GmbH & Co. KG in some countries.



SD means Secure Digital.

Contents		Page
<b>Chapter 1 Introduction</b>		
1.1	Validity of documentation	1-1
1.1.1	Retaining the documentation	1-1
1.2	Overview of documentation	1-2
1.3	Definition of symbols	1-3
<b>Chapter 2 Overview</b>		
2.1	Module features	2-1
2.2	Front view	2-2
<b>Chapter 3 Safety</b>		
3.1	Intended use	3-1
3.2	Safety regulations	3-3
3.2.1	Use of qualified personnel	3-3
3.2.2	Warranty and liability	3-3
3.2.3	Disposal	3-3
<b>Chapter 4 Function description</b>		
4.1	Module features	4-1
4.1.1	Integrated protection mechanisms	4-1
4.1.2	Supply voltage	4-1
4.2	INTERBUS	4-2
4.2.1	Connection to Interbus	4-2
4.2.2	Selector switch for setting the transmission rate	4-2
4.2.3	Selector switch for setting the INTERBUS parameters	4-3
4.3	USB port	4-4
<b>Chapter 5 Installation</b>		
5.1	General installation guidelines	5-1
5.1.1	Dimensions	5-1
5.2	Installing the head module	5-2
<b>Chapter 6 Interfaces</b>		
6.1	Interface assignment	6-1
6.1.1	Connection to INTERBUS	6-1
6.1.2	Connection via USB	6-2

---

---

**Chapter 7 Operation**

7.1	Messages	7-1
7.2	Display elements	7-2
7.2.1	Display elements for system diagnostics	7-2
7.2.2	Display elements for INTERBUS diagnostics	7-3
7.3	Diagnostic bytes	7-5
7.3.1	Structure and contents of the status byte (Byte 0)	7-5
7.3.2	Structure and contents of the slot byte (Byte 1)	7-5
7.3.3	Structure and contents of the channel byte (Byte 2)	7-5
7.3.4	Structure and contents of the module byte (Byte 3)	7-6

**Chapter 8 Technical details**

8.1	Technical details	8-1
8.2	Order reference	8-3

## 1.1 Validity of documentation

---

This documentation is valid for the **PSSu H IBSe** module. It is valid until new documentation is published.

Please also refer to the following documents:

- ▶ PSSuniversal System Description
- ▶ PSSuniversal Installation Manual

This operating manual explains the function and operation, describes the installation and provides guidelines on how to connect the product .

### 1.1.1 Retaining the documentation

This documentation is intended for instruction and should be retained for future reference.

## 1.2 Overview of documentation

---

### **1 Introduction**

The introduction is designed to familiarise you with the contents, structure and specific order of this manual.

### **2 Overview**

This chapter provides information on the module's most important features.

### **3 Safety**

This chapter must be read as it contains important information on safety and intended use.

### **4 Function Description**

This chapter describes the module's individual components.

### **5 Installation**

This chapter explains how to install the module.

### **6 Interfaces**

This chapter describes the module's interfaces.

### **7 Operation**

This chapter explains the display elements and advises on what to do if a fault occurs.

### **8 Technical Details**

This chapter contains the product's technical details and order reference.

## 1.3 Definition of symbols

---

Information that is particularly important is identified as follows:



### **DANGER!**

This warning must be heeded! It warns of a hazardous situation that poses an immediate threat of serious injury and death and indicates preventive measures that can be taken.



### **WARNING!**

This warning must be heeded! It warns of a hazardous situation that could lead to serious injury and death and indicates preventive measures that can be taken.



### **CAUTION!**

This refers to a hazard that can lead to a less serious or minor injury plus material damage, and also provides information on preventive measures that can be taken.



### **NOTICE**

This describes a situation in which the unit(s) could be damaged and also provides information on preventive measures that can be taken. It also highlights areas within the text that are of particular importance.



### **INFORMATION**

This gives advice on applications and provides information on special features.

# 1 Introduction

---

---

### 2.1 Module features

---

The product has the following features:

- ▶ **INTERBUS**-Interface for switching
  - Standard inputs/outputs
- ▶ USB port for connection to a PC for
  - Commissioning
  - Service
- ▶ LEDs for:
  - System status
  - USB status
  - Status of the **INTERBUS** interface
- ▶ Electronic modules that can be used for input/output:
  - All standard modules  
(PSSu E S...)

## 2.2 Front view

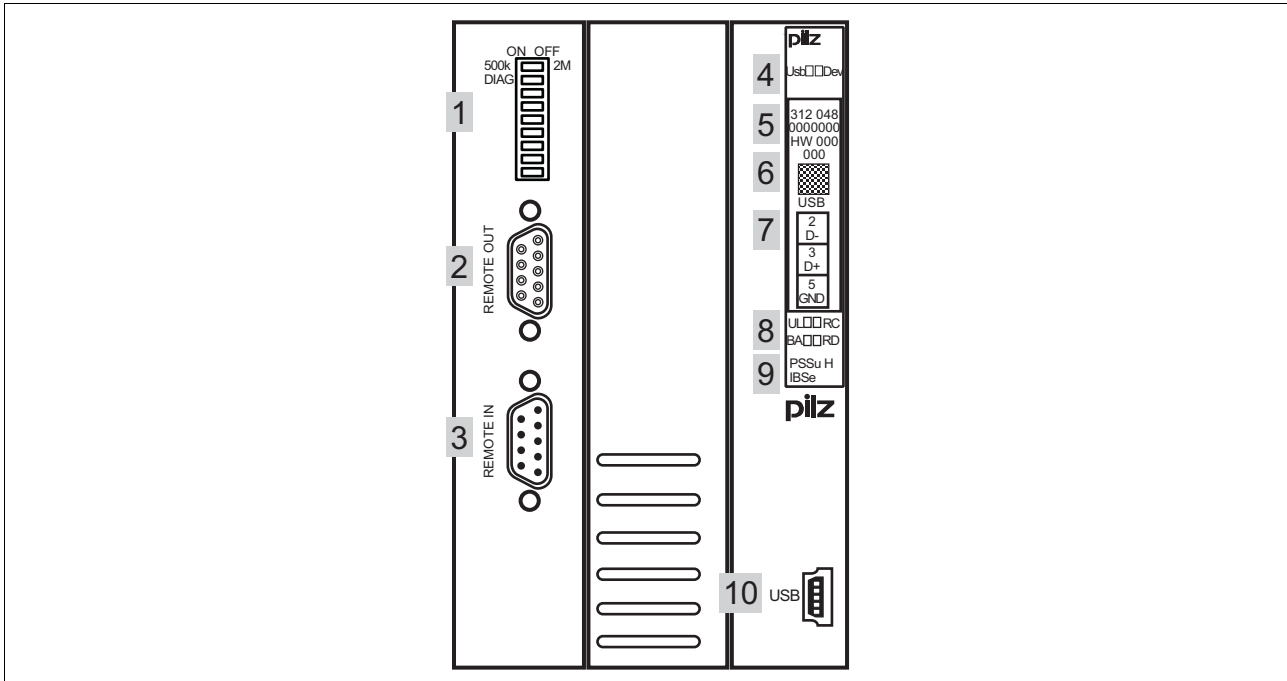

### Key:

- ▶ 1: Selector switch for setting the transmission rate and other Interbus parameters
- ▶ 2: Interbus interface for remote bus OUT
- ▶ 3: Interbus interface for remote bus IN
- ▶ 4: LEDs for system diagnostics
- ▶ 5: Labelling strip with:
  - Order number
  - Serial number
  - Hardware version number
  - Firmware version number on delivery
- ▶ 6: Field for 2D code
- ▶ 7: Labelling strip with interface configuration of the USB port
- ▶ 8: LEDs for Interbus diagnostics
- ▶ 9: Description of head module
- ▶ 10: USB port (Mini-B)

## 3.1 Intended use

The module is designed for use in:

- ▶ Non-safety-related applications with
  - **INTERBUS**

Intended use includes making the electrical installation EMC-compliant. Please refer to the guidelines stated in the "PSSuniversal Installation Manual". The module is designed for use in an industrial environment. It is not suitable for use in a domestic environment, as this can lead to interference.

The following is deemed improper use in particular:

- ▶ Any component, technical or electrical modification to the module
- ▶ Use of the module outside the areas described in this manual
- ▶ Use of the module outside the technical details (see chapter entitled "Technical Details")



### INFORMATION

The module is supported by the PSSuniversal Configurator and PSSuniversal Assistant from Version 1.4.0. We recommend that you always use the latest version (download from [www.pilz.de](http://www.pilz.de)).

The head module may be used in conjunction with the following electronic modules:

Module type	Module name
Voltage supply	PSSu E F PS(-T)
	PSSu E F PS1(-T)
	PSSu E F PS-P(-T)
Digital input/output modules	PSSu E S 4DI(-T)
	PSSu E S 4DO 0.5(-T)
	PSSu E S 2DO 2(-T)
Analogue input/output modules	PSSu E S 2AI I se(-T)
	PSSu E S 4AI U(-T)
	PSSu E S 2AI U(-T)
	PSSu E S 2AO I(-T)
	PSSu E S 4AO U(-T)
	PSSu E S 2AO U(-T)
Counter modules	PSSu E S ABS SSI(-T)
	PSSu E S INC(-T)
Voltage distribution	PSSu E PD(-T)
	PSSu E PD1(-T)

## 3.1 Intended use

---

The module's firmware can be updated to a later version using the Firmware Manager on the PSSuniversal Assistant. For the reason, the module's actual firmware version may not always match the firmware version printed on the front of the unit. Updating the firmware can also expand the module's functionality.



### **INFORMATION**

The module's actual firmware version can only be established using the Firmware Manager on the PSSuniversal Assistant.

## 3.2 Safety regulations

---

### 3.2.1 Use of qualified personnel

The products may only be assembled, installed, programmed, commissioned, operated, maintained and decommissioned by competent persons.

A competent person is someone who, because of their training, experience and current professional activity, has the specialist knowledge required to test, assess and operate the work equipment, devices, systems, plant and machinery in accordance with the general standards and guidelines for safety technology.

It is the company's responsibility only to employ personnel who:

- ▶ Are familiar with the basic regulations concerning health and safety / accident prevention
- ▶ Have read and understood the safety guidelines given in this description
- ▶ Have a good knowledge of the generic and specialist standards applicable to the specific application.

### 3.2.2 Warranty and liability

All claims to warranty and liability will be rendered invalid if:

- ▶ The product was used contrary to the purpose for which it is intended
- ▶ Damage can be attributed to not having followed the guidelines in the manual
- ▶ Operating personnel are not suitably qualified
- ▶ Any type of modification has been made (e.g. exchanging components on the PCB boards, soldering work etc.).

### 3.2.3 Disposal

- ▶ In safety-related applications, please comply with the mission time  $t_M$  in the safety-related characteristic data.
- ▶ When decommissioning, please comply with local regulations regarding the disposal of electronic devices (e.g. Electrical and Electronic Equipment Act).



## 4 Function description

---

### 4.1 Module features

---

#### 4.1.1 Integrated protection mechanisms

The module has the following protection mechanisms:

- ▶ Potentially isolated **INTERBUS** interface
- ▶ When the PSSu E F PS1(-T) is used to supply the system, the module supply is buffered for 20 ms if the supply voltage is interrupted.

#### 4.1.2 Supply voltage

Module supply

- ▶ The module supply provides the module with voltage.

## 4.2 INTERBUS

### 4.2.1 Connection to Interbus

A PSSu system with INTERBUS interface is a passive subscriber (Slave) of the INTERBUS remote bus without PCP channel.

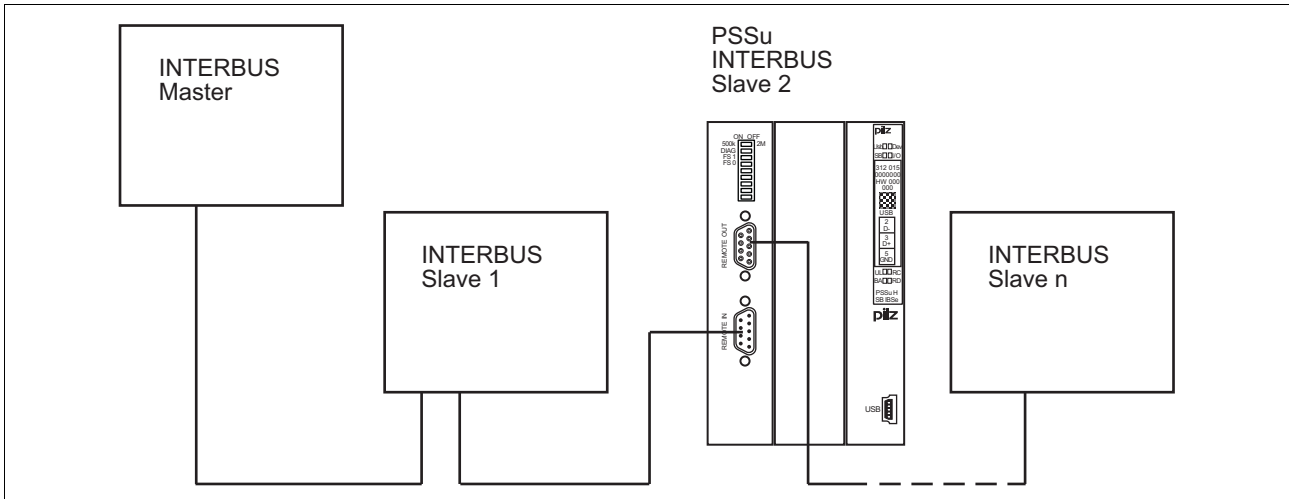

### 4.2.2 Selector switch for setting the transmission rate

The INTERBUS transmission rate of a PSSu is set via the DIP switch labelled “500k” and “2M”.

Switch designation	Position		
	off	on	
“500k”/“2M”	500 kBit/s	2 Mbit/s	
DIAG	Parameter		
--	Not assigned		



#### INFORMATION

The INTERBUS transmission rate should **only** be set when the module is switched off (no voltage applied).

The settings are **only** transferred when booting. Any changes made to the settings during operation will **not** be transferred.

## 4.2 INTERBUS

### 4.2.3 Selector switch for setting the INTERBUS parameters

The INTERBUS parameter can be used to display diagnostic data in the ST-P11. This INTERBUS parameter is set via the DIP switch labelled “DIAG”.

Four diagnostic bytes are transferred and displayed in the ST-P11.



**INFORMATION**

Further information on the structure and contents of the diagnostic byte can be found under “Operation”.

Switch designation	Position	
	off	on
“500k”/“2M”	Transmission rate	
DIAG	Do not transfer diagnostic bytes	Transfer diagnostic bytes
--	Not assigned	



**INFORMATION**

INTERBUS parameters can be modified during operation. In the ST-P11, diagnostic bytes are added or hidden via the “DIAG” switch. As a result, the position of all the subsequent bits in the ST-P11 may be shifted.

You can view the current process image in the PSSuniversal Assistant.

### 4.3 USB port

---

The following functions are available via the USB port:

- ▶ Show actual hardware
- ▶ Comparison of actual/registered hardware
- ▶ Display and update firmware versions
- ▶ Setting the parameters for the ST section

Parameters for the module's ST section can either be set via the fieldbus interface or via the USB port. Parameter setting via the USB port has priority over parameter setting via the fieldbus interface. Once parameters for the the head module have been set via the USB port, the ability to set parameters for the module via the fieldbus interface is disabled. The disable can be lifted in the PSSuniversal Assistant.

Procedure for connecting the head module via the USB port:

- ▶ Connect PC to head module via USB cable.
- ▶ Install USB driver.
- ▶ View the actual hardware registry in the PSSuniversal Assistant and call up other functions.

This way it is possible to copy and edit an existing configuration in the PSSuniversal Assistant.



#### **INFORMATION**

The USB driver can be found on the PSSuniversal Assistant CD-ROM, in the subdirectory \bin\PILZ\_USB\_DRIVER

## 5.1 General installation guidelines

Please also refer to the PSSuniversal Installation Manual.

The description below assumes that the mounting rail is already installed.



### CAUTION!

Damage due to electrostatic discharge!

Electrostatic discharge can damage components. Ensure against discharge before touching the product, e.g. by touching an earthed, conductive surface or by wearing an earthed arm-band.

### 5.1.1 Dimensions

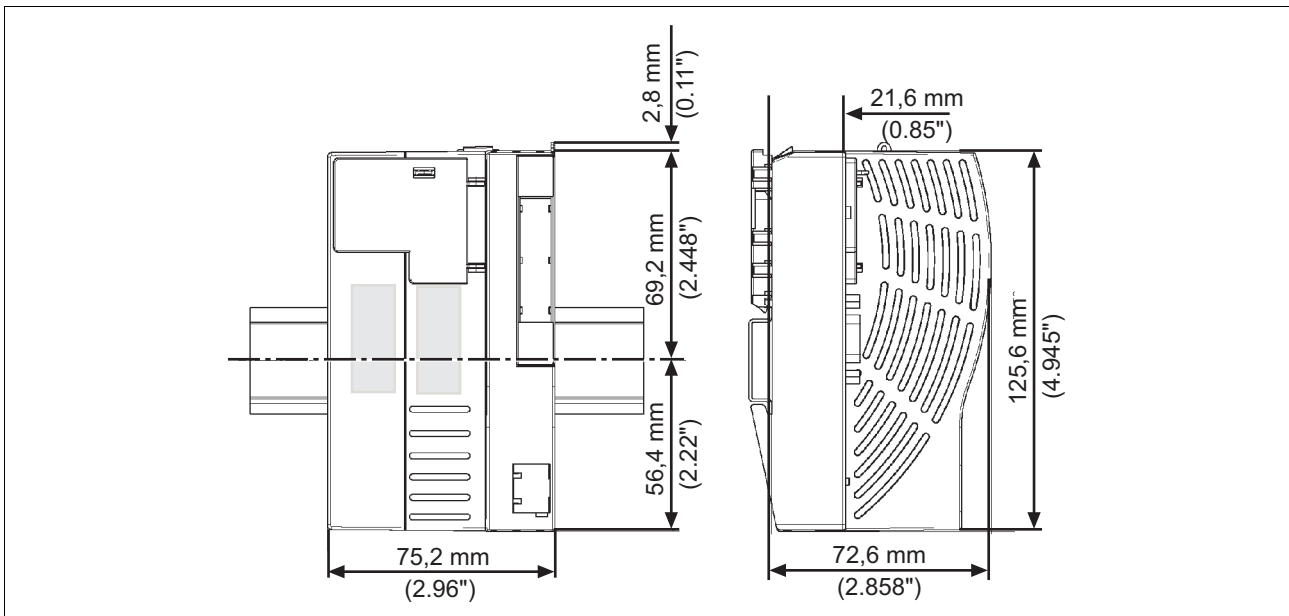

## 5.2 Installing the head module

Prerequisite:

- ▶ The mounting rail must be installed.



Procedure:

- ▶ Install an end bracket to the left of the head module or leave enough space for one.
- ▶ Slot the groove on the head module on to the mounting rail from below [1].
- ▶ Push the head module back [2] until you hear it lock into position.

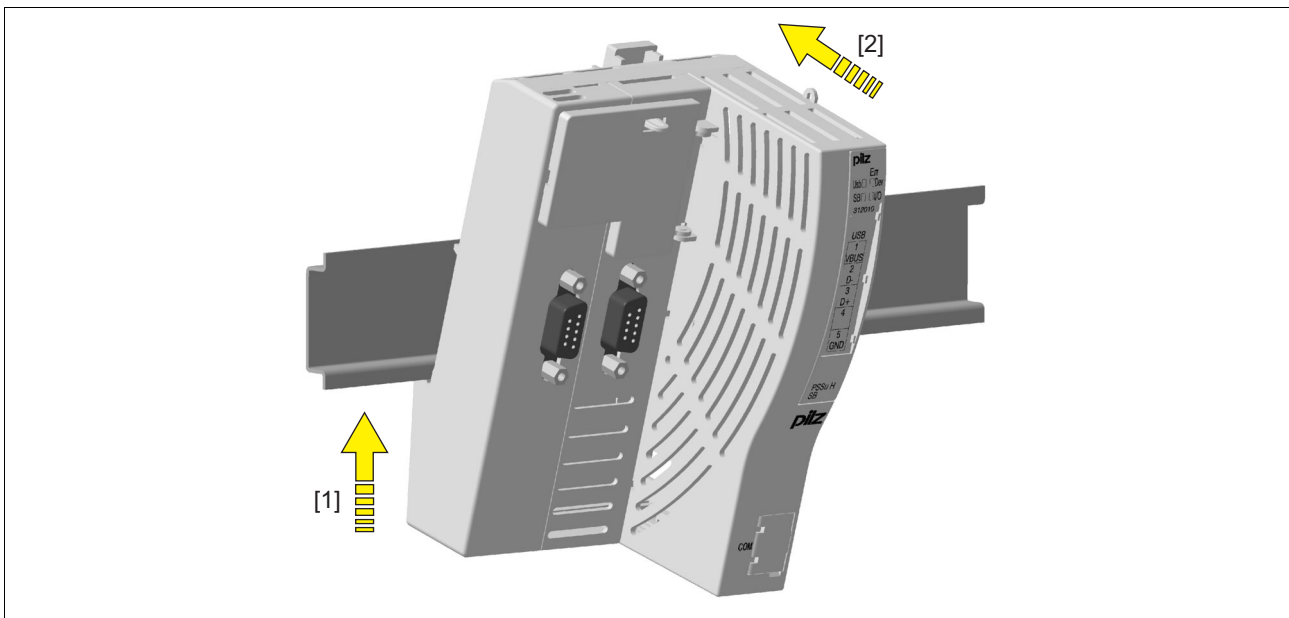
Schematic representation:

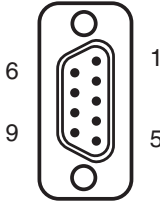
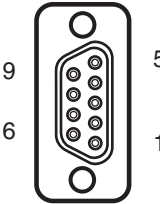

## 6.1 Interface assignment

INTERBUS IBS IN	Layout	
Male 9-pin D-SUB connector conforms to the guidelines of the INTERBUS User Group	1: DO 2: DI 3: GND 4: GND 5: n.c. 6: DO- 7: DI- 8: + 5 V 9: n.c.	
INTERBUS IBS OUT	Layout	
Female 9-pin D-SUB connector conforms to the guidelines of the INTERBUS User Group	1: DO 2: DI 3: GND 4: GND 5: + 5 V 6: DO- 7: DI- 8: + 5 V 9: n.c.	
USB	Layout	
Mini-B USB connector	1: n.c. 2: D- USB Data - 3: D+ USB Data + 4: n.c. 5: GND Ground	

► n.c. = not connected

### 6.1.1 Connection to INTERBUS

The connection to INTERBUS is made via a male 9-pin D-SUB connector "IBS-IN" and a female 9-pin D-SUB connector "IBS-OUT". Please refer to the guidelines issued by the INTERBUS Club.

The INTERBUS specification stipulates equipotential bonding between the INTERBUS subscribers. Connect the screen from the incoming interface on the PSS ('IBS-IN') to the screen on the outgoing interface of the INTERBUS subscriber immediately before it in the bus topology.

This equipotential bonding cable must have a cross section of at least 10 mm<sup>2</sup>. The equipotential bonding cable can also be connected to the functional earth of the PSSu, e.g. via the C-rail.

## 6 Interfaces

---

### 6.1 Interface assignment

---

#### 6.1.2 Connection via USB

Please note the requirements of the USB standard for USB 2.0 and for Mini-B USB ports.

The maximum cable runs for USB connection cable are 5 m.

## 7.1 Messages

All errors and faults detected by the electronic modules on a PSSu are signalled to the head module and entered in the head module's error stack.

Module error	Explanation	Remedy
Start-up error	Error as the PSSu system starts up	Change faulty module.
Configuration Error	Incorrect module type configured.	The configured hardware registry does not match the actual hardware registry.
ST communication error	Error during ST communication	Change faulty module.
Bus termination error	There is no terminating plate or there is a bad contact with the module bus.	Install a terminating plate with integrated end bracket or insert the base modules together correctly.
Temperature error: Too warm <sup>(1)</sup>	Ambient temperature too high: Error stack entry	Ensure there is sufficient ventilation in the control cabinet or prevent overload.
Temperature error: Too hot <sup>(1)</sup>	Ambient temperature too high: Module reset	Ensure there is sufficient ventilation in the control cabinet or prevent overload.
Overvoltage error	A system voltage or infeed is too high.	Stabilise the supply or change the faulty supply voltage module.
Undervoltage error	A system voltage or infeed is too low.	Stabilise the supply or change the faulty supply voltage module.

<sup>(1)</sup> There are two levels of overtemperature.

▶ Too warm:

If a module's temperature exceeds a threshold value, the module sends a warning to the head module. If the temperature drops back below the threshold value, the module sends an all-clear.

▶ Too hot:

If a module's temperature exceeds a further threshold value, the module sends an error message to the head module.

## 7.2 Display elements

Legend:

☀	LED on
◐	LED flashes
●	LED off

### 7.2.1 Display elements for system diagnostics

The module has LEDs to display various PSSu states (“Usb” LED and “Dev” LED).

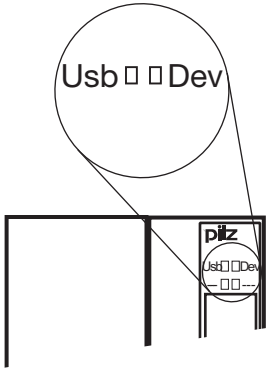
	LED			Key
	Description	Colour	Status	
Usb	- - -		●	No data is being transmitted via the USB port
	Green		☀	Data is being transmitted via the USB port
Dev	- - -		●	PSSu system error, no start-up
	Green		☀	PSSu running without error
	Red		☀	Error in the head module
	Red		◐	Error on the module bus (*1)

(\*1) An error on the module bus (flashing red LED) may be due to one of the following reasons, which are stored in the error stack:

1. The head module cannot determine the registered hardware. Possible causes:

- ▶ Module bus is incomplete
- ▶ Terminating resistor is missing.
- ▶ A module is defective
- ▶ A module does not have valid software.
- ▶ Invalid hardware registry
- ▶ Too many modules

## 7.2 Display elements

Remedy: Correct the hardware registry.

2. Error: A module is missing. Possible cause:

- ▶ The module has been removed.
- ▶ The module has an error and is no longer registering after a reset.
- ▶ The module has an error and switches to a system stop.
- ▶ The module no longer has a voltage supply.

Remedy: Rectify the above points.

### 7.2.2 Display elements for INTERBUS diagnostics

The module has two LEDs to display the status of the supply ("RC" and "UL" LED).

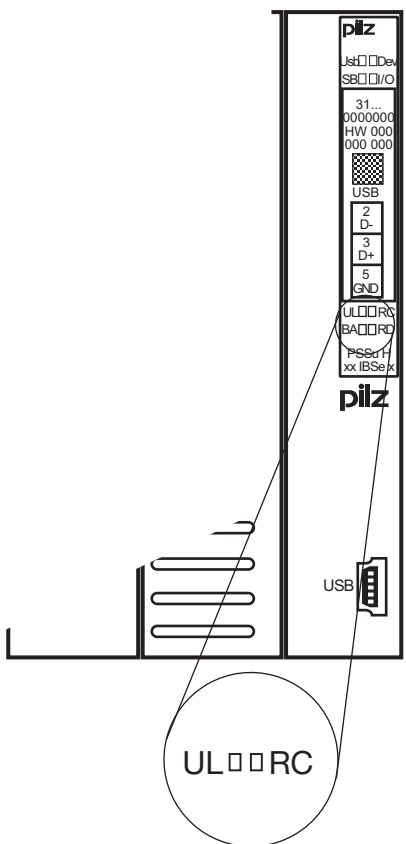
	LED for INTERBUS diagnostics Status of the supply		Key
	"UL"	"RC"	
	●	●	No supply voltage to the INTERBUS interface. The INTERBUS interface is not ready for operation.
	☀	●	The supply voltage to the INTERBUS interface is switched on. The cable connection of the remote bus IN is defective or the Interbus master is in a reset condition.
	☀	☀	The supply voltage to the INTERBUS interface is switched on. The INTERBUS interface is ready for operation.

## 7.2 Display elements

The module has two LEDs to display the status of the data transfer (“RD” and “BA” LED).

	LED for INTERBUS diagnostics Status of the data transfer		Key
	Description	Status	
	RD		The remote bus OUT is switched on.
			The remote bus OUT is switched off.
BA		No data transfer	
		Data is being transmitted	

## 7.3 Diagnostic bytes

### 7.3.1 Structure and contents of the status byte (Byte 0)

Bit number	Signal	Key
0	0	SafetyBUS p is not ready
	1	SafetyBUS p is ready
1	0	SafetyBUS p input group is in a STOP condition.
	1	SafetyBUS p input group is in a RUN condition.
2	0	SafetyBUS p output group is in a STOP condition.
	1	SafetyBUS p output group is in a RUN condition.
3	0	No error in the PSSu FS section
	1	Error in the PSSu FS section
4	0	No error in the PSSu ST section
	1	Error in the PSSu ST section
5		Reserved
6		Reserved
7		Not defined

### 7.3.2 Structure and contents of the slot byte (Byte 1)

The slot byte (Byte 1) contains the slot number for the following diagnostic bytes (Byte 2/ Byte 3).

### 7.3.3 Structure and contents of the channel byte (Byte 2)

The channel byte (Byte 2) contains the following bits:

- ▶ 0 – 3: Channel number of the subsequent diagnostics
- ▶ 0xFF: Module diagnostics

## 7.3 Diagnostic bytes

### 7.3.4 Structure and contents of the module byte (Byte 3)

Diagnostic value	Description
0	No diagnostic value available
1	Short circuit
2	Undervoltage error (supply voltage modules)
3	Overvoltage error (supply voltage modules)
4	Overload
5	Temperature error: Too warm
6	Open circuit
7	Input value greater than limit value 2 (limit value monitoring, analogue modules)
8	Input value less than limit value 1 (limit value monitoring, analogue modules)
9	General module error
10	Reserved
11	Reserved
12	Reserved
13	Reserved
14	Reserved
15	Reserved
16	Protocol error
17	Error in the local enable principle (FS output modules)
18	Error in the parameter setup
19	Value below the lower limit value (range monitoring, analogue modules)
20	Value exceeds the upper limit value (range monitoring, analogue modules)
21	Configuration error
22-255	Not defined

## 8.1 Technical details

<b>Technical details</b>	
Application range	<b>Standard</b>
Module's device code	<b>0203h</b>
<b>Electrical data</b>	
Internal supply voltage	
Supply voltage range of module supply	<b>4.9 - 5.1 V</b>
Current and power consumption from module supply	
Module's current consumption without FO connection	<b>620 mA</b>
Module's power consumption without FO connection	<b>3.10 W</b>
Max. power dissipation of the module	<b>3.10 W</b>
Potential isolation between module supply and	<b>700 V</b>
<b>INTERBUS</b>	
<b>INTERBUS</b>	
Application range	<b>Standard applications</b>
Device type	<b>Slave</b>
Maximum data length of the fieldbus interface: Input	<b>64 Byte</b>
Maximum data length of the fieldbus interface: Output	<b>64 Byte</b>
Maximum data length of the fieldbus interface: Diagnostics	<b>4 Byte</b>
Transmission rates	<b>2 MBit/s, 500 kBit/s</b>
Set via	<b>DIP switch</b>
Connection	<b>Male 9-pin D-SUB connector/female 9-pin D-SUB connector</b>
Protocol	<b>INTERBUS-Protokoll</b>
Operating modes	<b>Slave Mode</b>
Manufacturer's ID	<b>248h</b>
<b>USB</b>	
Connection	<b>Mini-B connector</b>
<b>Environmental data</b>	
Climatic suitability	<b>EN 60068-2-14, EN 60068-2-1, EN 60068-2-2, EN 60068-2-30, EN 60068-2-78</b>
Ambient temperature	<b>0 - 60 °C</b>
Storage temperature	<b>-25 - 70 °C</b>
Climatic suitability in accordance with <b>EN 60068-2-78</b>	<b>93 % r. h. at 40 °C</b>
Condensation	<b>no</b>
EMC	<b>EN 61000-4-2, EN 61000-4-3, EN 61000-4-4, EN 61000-4-5, EN 61000-4-6, EN 61000-6-2, EN 61000-6-4</b>
Vibration to <b>EN 60068-2-6</b>	
Frequency	<b>10 - 150 Hz</b>
Max. acceleration	<b>1g</b>
Shock stress	
<b>EN 60068-2-27</b>	<b>15g 11 ms</b>
<b>EN 60068-2-29</b>	<b>10g 16 ms</b>
Protection type	
Mounting (e.g. cabinet)	<b>IP54</b>
Housing	<b>IP20</b>
Airgap creepage in accordance with <b>EN 60664-1</b>	
Overvoltage category	<b>II</b>
Pollution degree	<b>2</b>

## 8.1 Technical details

---

### Mechanical data

Housing material

Front **PC**

Bottom **PC**

Dimensions

Height **128.4 mm**

Width **75.2 mm**

Depth **79.4 mm**

Weight **170 g**

---

## 8.2 Order reference

---

Order reference	
Description	Order no.
PSSu H IBSe (Head module with INTERBUS interface via copper cable)	312 048





► ...  
In many countries we are represented by our subsidiaries and sales partners.

Please refer to our homepage for further details or contact our headquarters.

Pilz GmbH & Co. KG  
Felix-Wankel-Straße 2  
73760 Ostfildern, Germany  
Telephone: +49 711 3409-0  
Telefax: +49 711 3409-133  
E-Mail: [pilz.gmbh@pilz.de](mailto:pilz.gmbh@pilz.de)  
Internet: [www.pilz.com](http://www.pilz.com)

## ► Technical support

+49 711 3409-444  
[support@pilz.com](mailto:support@pilz.com)

# pilz

InduraneT p<sup>®</sup>, Pilz<sup>®</sup>, PIT<sup>®</sup>, PMCprotego<sup>®</sup>, PMI<sup>®</sup>, PNOZ<sup>®</sup>, Primo<sup>®</sup>, PSEN<sup>®</sup>, PSS<sup>®</sup>, PVIS<sup>®</sup>, SafetyBUS P<sup>®</sup>, SafetyEYE<sup>®</sup>, SafetyNET p<sup>®</sup>, the spirit of safety<sup>®</sup> are registered and protected trademarks of Pilz GmbH & Co. KG in some countries. We would point out that product features may vary from the details stated in this document, depending on the status at the time of publication and the scope of the equipment. We accept no responsibility for the validity, accuracy and entirety of the text and graphics presented in this information. Please contact our Technical Support if you have any questions.