



▶ PSSu E S INC 24V se(-T)

PILZ

THE SPIRIT OF SAFETY

Operating Manual-1001380-EN-06

- Decentralised system PSSuniversal I/O



This document is the original document.

Where unavoidable, for reasons of readability, the masculine form has been selected when formulating this document. We do assure you that all persons are regarded without discrimination and on an equal basis.

All rights to this documentation are reserved by Pilz GmbH & Co. KG. Copies may be made for the user's internal purposes. Suggestions and comments for improving this documentation will be gratefully received.

Pilz®, PIT®, PMI®, PNOZ®, Primo®, PSEN®, PSS®, PVIS®, SafetyBUS p®, SafetyEYE®, SafetyNET p®, the spirit of safety® are registered and protected trademarks of Pilz GmbH & Co. KG in some countries.



SD means Secure Digital

1	Introduction	5
1.1	Validity of documentation	5
1.1.1	Retaining the documentation	5
1.1.2	Terminology: System environment A and B	5
1.2	Definition of symbols	6
2	Overview	7
2.1	Module structure	7
2.2	Module features	7
2.3	Front view	8
3	Safety	10
3.1	Intended use	10
3.2	Safety regulations	12
3.2.1	Use of qualified personnel	12
3.2.2	Warranty and liability	12
3.2.3	Disposal	12
4	Function description	13
4.1	Block diagram	13
4.2	Module features	13
4.2.1	Integrated protection mechanisms	13
4.2.2	Function description	13
4.2.2.1	Functional inputs (G, L, S)	14
4.2.2.2	Supply voltage for encoder	14
4.2.2.3	Overflow	15
4.2.3	Incremental encoder operating mode	15
4.2.4	Counter operating mode	16
4.2.5	Functions	17
4.2.5.1	Measure period length	17
4.2.5.2	Transfer counter status via latch pulse	18
4.2.5.3	Transfer counter status via zero pulse	19
4.2.5.4	Set counter status	20
4.2.5.5	Monitor limit value	21
4.3	Configuration	22
4.3.1	Operating modes and parameters	22
4.3.2	Input/output data	23
4.3.2.1	PSSu assignment in system environment A	23
4.3.2.2	PSSu assignment in system environment B	25
5	Installation	27
5.1	General installation guidelines	27
5.1.1	Dimensions	27
5.2	Installing the base module	27
5.3	Inserting and removing an electronic module	28
5.3.1	Inserting an electronic module	29
5.3.2	Removing an electronic module	30
5.3.3	Changing an electronic module during operation	30

6	Wiring	31
6.1	General wiring guidelines.....	31
6.1.1	Mechanical connection of the base modules	31
6.2	Terminal configuration.....	34
6.3	Connecting the module	36
7	Operation	38
7.1	Messages.....	38
7.2	Display elements.....	38
7.2.1	Display elements for module diagnostics.....	38
7.2.2	Display elements for counter status.....	39
7.2.3	Display elements for status of the functional inputs.....	39
7.3	Status information	39
8	Technical details	40
9	Supplementary data	43
9.1	Permitted operating height.....	43
10	Order reference	44
10.1	Product.....	44
10.2	Accessories.....	44

1 Introduction

1.1 Validity of documentation

This documentation is valid for the products PSSu E S INC 24V se and PSSu E S INC 24V se-T. It is valid until new documentation is published.

This operating manual explains the function and operation, describes the installation and provides guidelines on how to connect the product.

The module PSSu E S INC 24V se-T is suitable for use where there are increased environmental requirements (see Technical details).

1.1.1 Retaining the documentation

This documentation is intended for instruction and should be retained for future reference.

1.1.2 Terminology: System environment A and B

The PSSu system can be used in two different system environments. The module's application area is described in the chapter "Intended Use" of the manual.

The distinction is made between

- ▶ PSSu in system environment A
- ▶ PSSu in system environment B

The distinction is based on the application area of the PSSu system.

PSSu in system environment A may be used in the

- ▶ Decentralised system PSSu I/O
- ▶ **Not** in the automation system PSS 4000

PSSu in system environment B may be used in the

- ▶ Automation system PSS 4000, e.g. with
 - Decentralised system PSSu I/O with SafetyNET p
 - Control system PSSu PLC
 - Control system PSSu multi

1.2 Definition of symbols

Information that is particularly important is identified as follows:



DANGER!

This warning must be heeded! It warns of a hazardous situation that poses an immediate threat of serious injury and death and indicates preventive measures that can be taken.



WARNING!

This warning must be heeded! It warns of a hazardous situation that could lead to serious injury and death and indicates preventive measures that can be taken.



CAUTION!

This refers to a hazard that can lead to a less serious or minor injury plus material damage, and also provides information on preventive measures that can be taken.



NOTICE

This describes a situation in which the product or devices could be damaged and also provides information on preventive measures that can be taken. It also highlights areas within the text that are of particular importance.



INFORMATION

This gives advice on applications and provides information on special features.

2 Overview

2.1 Module structure

A module consists of

- ▶ Electronic module and
- ▶ Base module with
 - Screw terminals or
 - Cage clamp terminals

The base modules are the carrier units for the electronic modules and are used to connect the field wiring. The electronic modules are inserted on to the base modules and determine the module's function.

Details of the base modules that can be used are available in the chapter entitled “Intended Use”.

2.2 Module features

The product has the following features:

- ▶ Connection of a rotary encoder with HTL output signal
- ▶ Inputs for
 - Counter pulses (inputs A, B), single-pole, referenced to earth (single-ended)
 - Zero pulse (inputs C), single-pole, referenced to earth (single-ended)
 - Stopping the counter (input G, Gate)
 - Memory function (Input L, Latch)
 - Rotary encoder status (Input S, Status)
- ▶ Outputs:
 - 24 VDC supply voltage for encoder
 - 1 semiconductor output (switches depending on the counter status)
- ▶ Resolution of the counter and latch memory: 32 Bit
- ▶ Operating modes:
 - Incremental encoder
 - Counter
- ▶ Pulse multiplication (up to four times)
- ▶ No potential isolation between periphery supply and inputs/outputs
- ▶ LEDs for:
 - Data transfer per input A, B, C
 - Status per functional input (Gate, Latch, Status)
 - Module error
- ▶ For standard applications in system environment A and B
- ▶ T-type:
 - PSSu E S INC 24V se-T: for increased environmental requirements

2.3 Front view

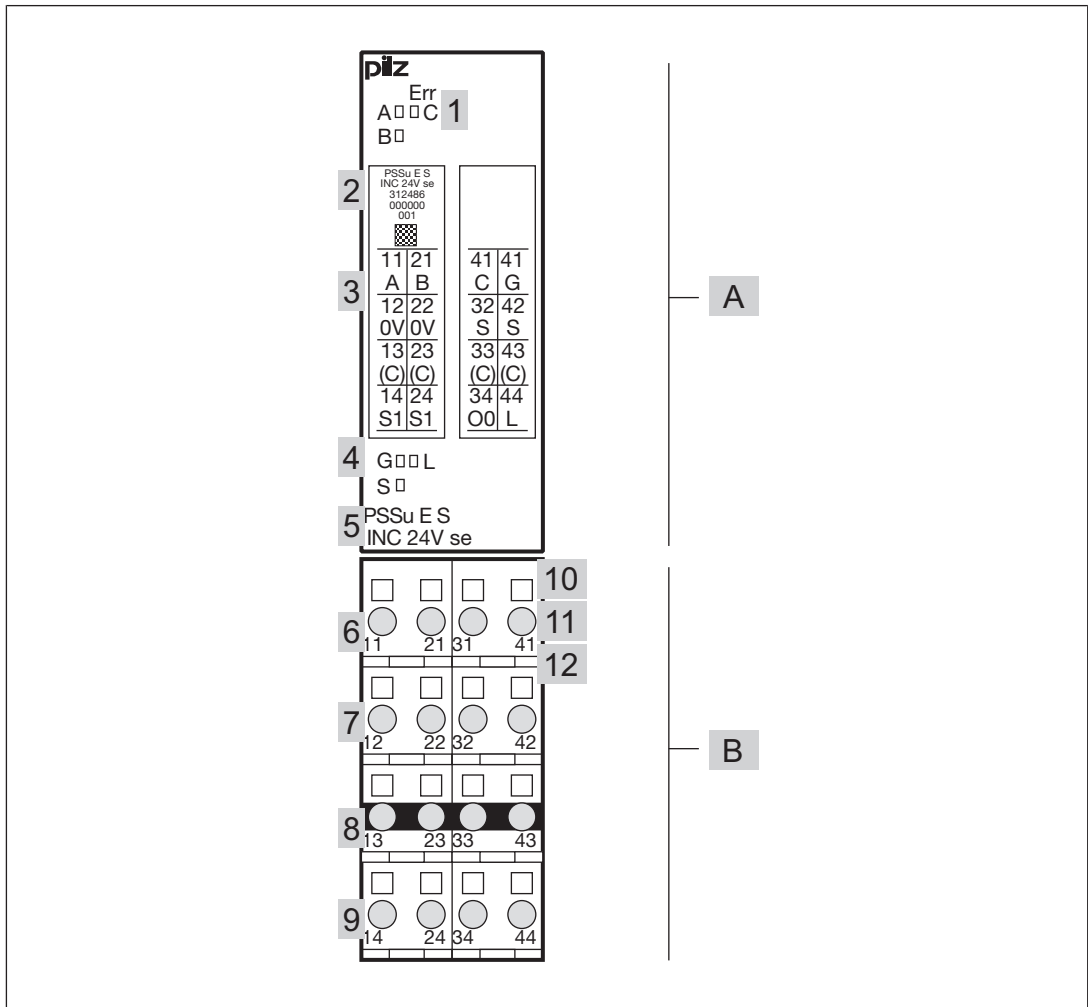

Legend:

- ▶ A: Electronic module
- ▶ B: Base module
- ▶ 1: LEDs for
 - Module diagnostics
 - Status of the input channels A, B, C
- ▶ 2: Labelling strip with:
 - Name of electronic module
 - Order number
 - Serial number
 - Hardware version number
 - 2D code
- ▶ 3: Labelling strip for the terminal configuration on the base module
- ▶ 4: LEDs for
 - Status of function inputs G, L, S
- ▶ 5: Name of electronic module

- ▶ 6: Connection level 1 (terminals 11, 21, 31, 41)
- ▶ 7: Connection level 2 (terminals 12, 22, 32, 42)
- ▶ 8: Connection level 3 (terminals 13, 23, 33, 43)
- ▶ 9: Connection level 4 (terminals 14, 24, 34, 44)
- ▶ 10: Square mounting holes (connection levels 1, 2, 3 and 4)
 - With screw to loosen/tighten the screw terminal on base modules with screw terminals
 - With mechanism to operate the cage clamp on base modules with cage clamp terminals
- ▶ 11: Round connection holes (connection levels 1, 2, 3 and 4) for connecting the signal lines
- ▶ 12: Mounting slot for colour marker to label the connection level (connection levels 1, 2, 3 and 4)

3 Safety

3.1 Intended use



INFORMATION

If the module name is not explicitly named, the details apply to all the variants of the module.

Use in a PSSu system

The module may be used in a PSSu system in system environment A and B.

The head module establishes in what system environment a PSSu system can be used.

▶ System environment A

A PSSu system in system environment A is a decentralised system PSSu I/O with a field-bus, but without SafetyNET p interface. The automation system PSS 4000 does **not** belong to the system environment A.

▶ System environment B

A PSSu system in system environment B is a PSSu system in the automation system PSS 4000. The PSSu system can belong to one of the following performance classes:

- Decentralised system PSSu I/O (with SafetyNET p)
- Control system PSSu PLC
- Control system PSSu multi

Standard applications

The module may be used for standard applications.

Module's function

The module can be used to connect an incremental encoder with HTL output signal for standard functions.

Particular application areas

▶ Increased environmental requirements

The module PSSu E S INC 24V se-T is suitable for use where there are increased environmental requirements (see Technical details).

▶ Lift applications

The modules PSSu E S INC 24V se and PSSu E S INC 24V se-T can be used in conjunction with PESSRAL modules (programmable electronic system in safety-related applications for lifts) in accordance with the Lifts Directive 2014/33/EU. The modules meet the requirements in accordance with EN 81-20, EN 81-22, EN 81-50 for passenger and goods lifts, as well as the requirements in accordance with EN 115-1 for escalators and moving walks.

The module/the safety controller should be installed in a protected environment. Example: Protected inside space or control cabinet with protection class and corresponding air conditioning specified in Technical details.

Operating height

With reference to the standard IEC 61131-2 the values stated in the technical details for ambient temperature are reduced at heights >2000 m operating height above sea level (see Supplementary data).

EMC-compliant installation

Intended use includes making the electrical installation EMC-compliant. Please refer to the guidelines stated in the "PSSuniversal Installation Manual". The module is intended for use in an industrial environment. Interference may occur if used within a domestic environment.

Improper use

The following is deemed improper use in particular

- ▶ Any component, technical or electrical modification to the module,
- ▶ Use of the module outside the areas described in this operating manual,
- ▶ Any use of the module that is not in accordance with the technical details.

Software tools

The module is supported by:

- ▶ PSSuniversal Configurator and PSSuniversal Assistant from Version 1.9.0.
- ▶ PAS4000 from Version 1.7.0



INFORMATION

We recommend that you always use the latest version of the software tool (download from www.pilz.com).

Base modules

The PSSu E S INC 24V se module may be used in conjunction with the following base modules:

- ▶ PSSu BP 2/16 S
- ▶ PSSu BP 2/16 C
- ▶ PSSu BP-C 2/16 S
- ▶ PSSu BP-C 2/16 C

The module PSSu E S INC 24V se-T may be used in conjunction with the following base modules:

- ▶ PSSu BP 2/16 S-T
- ▶ PSSu BP 2/16 C-T
- ▶ PSSu BP-C 2/16 S-T
- ▶ PSSu BP-C 2/16 C-T

3.2 Safety regulations

3.2.1 Use of qualified personnel

The products may only be assembled, installed, programmed, commissioned, operated, maintained and decommissioned by persons who are competent to do so.

A competent person is a qualified and knowledgeable person who, because of their training, experience and current professional activity, has the specialist knowledge required. In order to inspect, assess and handle products, devices, systems, plant and machinery, this person must be familiar with the state of the art and the applicable national, European and international laws, directives and standards.

It is the company's responsibility only to employ personnel who

- ▶ Are familiar with the basic regulations concerning health and safety / accident prevention,
- ▶ Have read and understood the information provided in the section entitled Safety
- ▶ Have a good knowledge of the generic and specialist standards applicable to the specific application.

3.2.2 Warranty and liability

All claims to warranty and liability will be rendered invalid if

- ▶ The product was used contrary to the purpose for which it is intended,
- ▶ Damage can be attributed to not having followed the guidelines in the manual,
- ▶ Operating personnel are not suitably qualified,
- ▶ Any type of modification has been made (e.g. exchanging components on the PCB boards, soldering work etc.).

3.2.3 Disposal

- ▶ In safety-related applications, please comply with the mission time T_M in the safety-related characteristic data.
- ▶ When decommissioning, please comply with local regulations regarding the disposal of electronic devices (e.g. Electrical and Electronic Equipment Act).

4 Function description

4.1 Block diagram

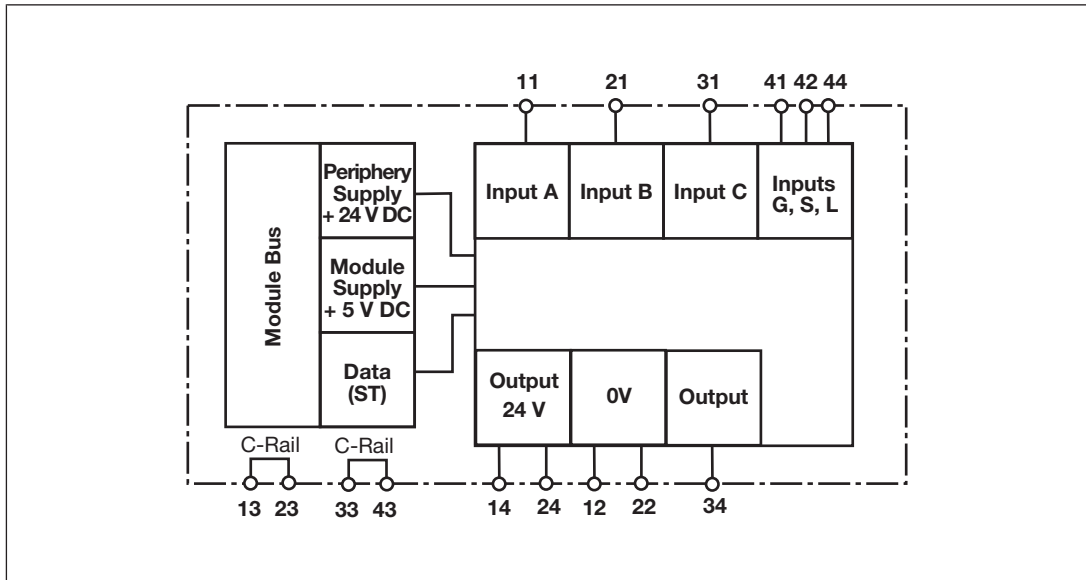

4.2 Module features

4.2.1 Integrated protection mechanisms

When the PSSu E F PS1(-T) or PSSu E F PS2(-T)(-R) is used to supply the system, the module supply is buffered for 20 ms if the supply voltage is interrupted.

The module detects the following errors:

- ▶ Start-up error
- ▶ Configuration error
- ▶ ST communication error
- ▶ Bus termination error
- ▶ Supply voltage overload for the encoder

4.2.2 Function description

Module supply

- ▶ The module supply provides the module with voltage.

Inputs

- ▶ 3 single-pole inputs referenced to earth: A, B, C, for connecting an incremental encoder or an encoder that provides rising edges as counter pulses.
- ▶ 3 single-pole inputs referenced to earth: G, L, S, for special functions

Outputs:

- ▶ Supply voltage for encoder, 24 VDC, 100 mA
- ▶ Semiconductor output (switches depending on the counter status)
 - “0” signal (0 V) at the output:
 - Output is high impedance
 - No current to the load
 - “1” signal (+24 V) at the output:
 - Output is low impedance
 - Current is supplied to the load

Operating modes

- ▶ Incremental encoder
- ▶ Counter

Functions

- ▶ Period length measurement
- or
- ▶ Storing the counter status in latch memory after a latch pulse or zero pulse
- ▶ Setting the counter status

The electronic module transfers the data and status information to the head module via the module bus. The choice of function and the function's configuration are defined via the system software.

4.2.2.1 Functional inputs (G, L, S)

The single-pole inputs (G, L, S) are used for special functions. Inputs G and L may be connected to external signal sources, e.g. to a higher order control system.

- ▶ Input G (gate input)

The counter is stopped with a 1 signal. The module ignores the counter pulses at the inputs until a 0 signal returns.
- ▶ Input L (input for latch pulse)

At a rising edge, the module stores the current counter value in the latch memory. The counter continues counting; it is not stopped by the latch pulse. The module transmits the stored value to the head module. The period length measurement may be configured as an alternative to the latch function.
- ▶ Input S (status input)

The encoder's fault signal output can be connected to the status input. The module transmits the input state to the head module with the status information.

4.2.2.2 Supply voltage for encoder

The module provides a supply voltage of 24 VDC / 100 mA to supply the rotary encoder.

The output is short circuit-proof. In the event of an overload, the supply voltage is switched off and a warning is issued on the bus. The supply voltage is re-established when the cause of the overload has been rectified.

4.2.2.3 Overflow

In both operating modes the counter can accept values from 0000 0000_H to FFFF FFFF_H.

- ▶ With an underflow the value drops below 0000 0000_H and the counter continues from FFFF FFFF_H.
- ▶ With an overflow the value FFFF FFFF_H is exceeded and the counter continues from 0000 0000_H.

The overflow or underflow is signalled to the head module as status information.

The status information overflow is reset:

- ▶ if the value again falls below 0000 0000_H (underflow).
- ▶ if 5555 0000_H is exceeded (the lower third of the value range).

The status information underflow is reset:

- ▶ if FFFF FFFF_H is exceeded again (overflow).
- ▶ if AAAA FFFF_H is exceeded (the upper third of the value range).

4.2.3 Incremental encoder operating mode

The counter outputs and the output for the incremental encoder's zero pulse are connected to the single-pole inputs (A, B, C).

▶ Inputs A, B

The first channel of the encoder is connected to input A, the second to input B. The second channel is 90° out of phase. If channel A is leading, the module counts forwards. If channel A is lagging, the module counts backwards (see timing diagram).

▶ Input C

The output for the incremental encoder's zero pulse is connected to input C. An incremental encoder typically supplies one zero pulse per rotation. If the zero pulse function is activated, the module copies the last value prior to the zero pulse into the latch memory and passes it to the process image of inputs (see chapter entitled "Transfer counter status via latch pulse").

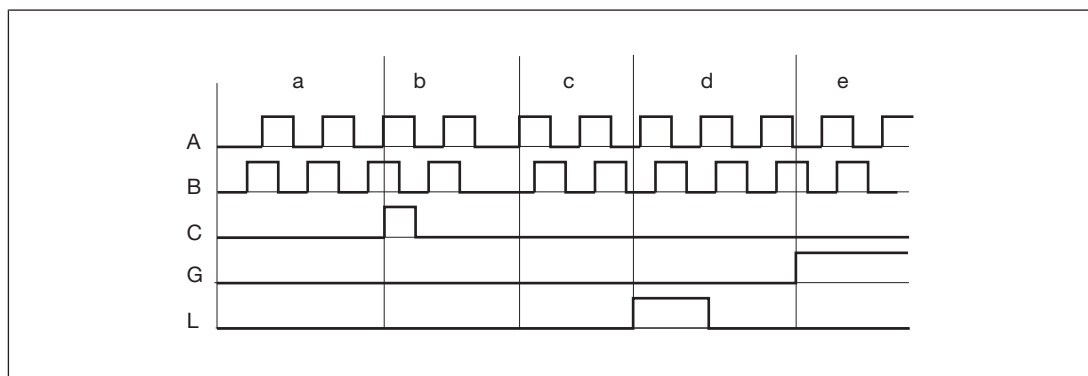

Legend:

- ▶ a: The counter counts backwards because the signal at channel A is lagging.
- ▶ b: The module has received a zero pulse. Provided the function is activated, the counter value is copied into the latch memory with a rising edge at input C.
- ▶ c: The counter counts forwards because the signal at channel A is leading.
- ▶ d: The module has received a latch pulse. Provided the function is activated, the counter value is copied into the latch memory with a rising edge at input L.

- ▶ e: The counter is disabled because there is a 1 signal at input G.

The module can evaluate the counter pulses once, twice or four times (configuration in the PSSu Configurator or PAS4000).

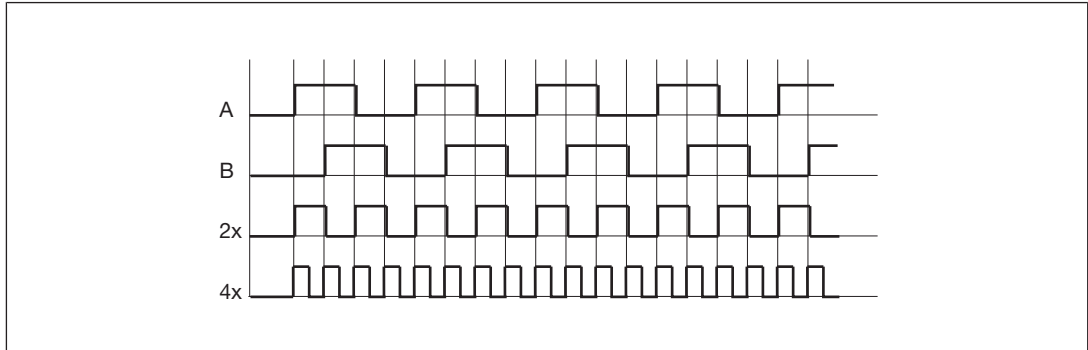

- ▶ Single evaluation:
Each rising edge at channel A increases the counter status.
- ▶ Double evaluation:
Each rising and each falling edge at channel A increases the counter status.
- ▶ Quadruple evaluation (default):
Each rising and each falling edge at channel A and channel B increases the counter status.

4.2.4 Counter operating mode

In counter operating mode, the module's single-pole inputs A, B, C have the following functions:

- ▶ Input A (Count)
Input A is the input for the encoder's counter pulses. The module counts each rising edge.
- ▶ Input B (Up/down)
At a 0 signal the module counts forwards. At a 1 signal the module counts backwards.
- ▶ Input C (Gate/Latch)
The counter is stopped with a 1 signal. The module ignores the counter pulses at the input until a 0 signal returns.

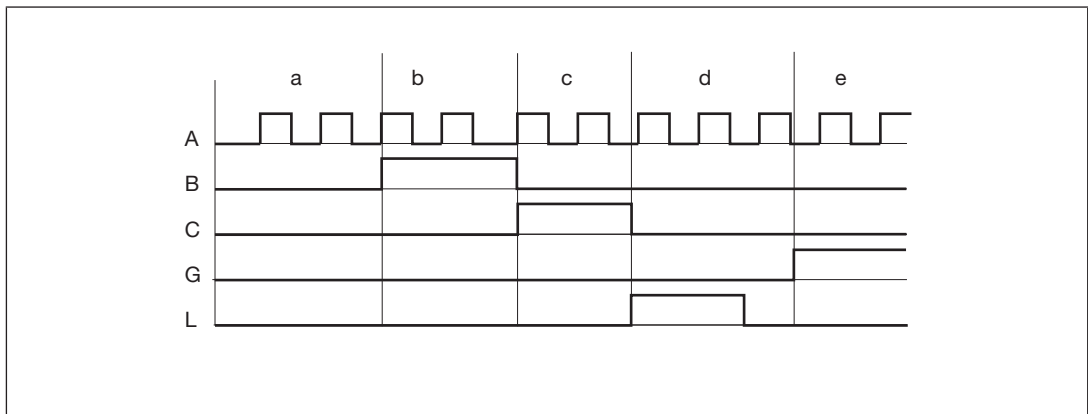

Legend:

- ▶ a: The counter counts forwards because there is 0 signal at channel B.

- ▶ b: At the next rising edge at channel A, the counter counts backwards because there is a 1 signal at channel B.
- ▶ c: The counter is disabled because there is a 1 signal at input C.
- ▶ d: The module has received a latch pulse. Provided the function is activated, the counter value is copied into the latch memory with a rising edge at input L.
- ▶ e: The counter is disabled because there is a 1 signal at input G.

4.2.5 Functions

4.2.5.1 Measure period length

The module can record the period length of the counter pulses on channel A. The period length is the time between two rising edges at channel A. It is transferred to the process image of inputs as multiple of 200 ns.

Prerequisite: This function is configured in the PSSu Configurator / PAS4000.

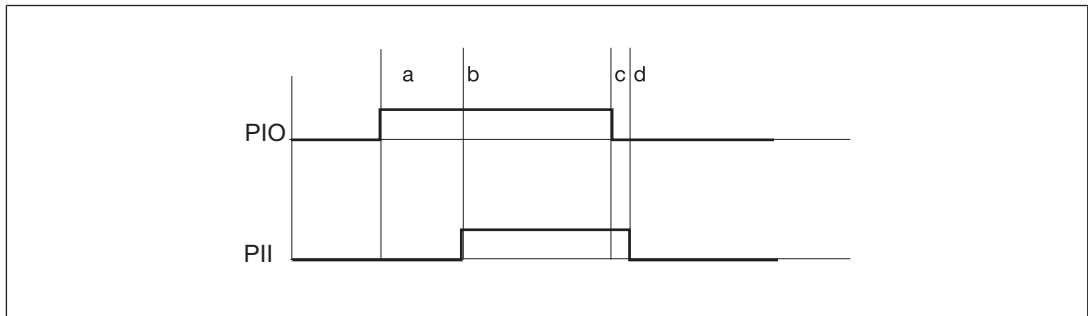

Legend:

- ▶ PIO: Bit 1 of the function call in the process image of outputs or I/O data OutputData.LatchOrMeasure
- ▶ PII: Bit 1 of the status byte in the process image of inputs or I/O data InputData.LatchOrMeasureDone

Key to timing diagram:

Section	Function	Procedure for PSSu in system environment A	Procedure for PSSu in system environment B
a	Start measurement	In the user program, set Bit 1 of the function call	In the user program, set OutputData.LatchOrMeasure
b	Output measured value Set status bit	Measured value is transferred into the process image of inputs The module sets Bit 1 of the status byte	Measured value is written in InputData.LatchOrPeriod The module sets InputData.LatchOrMeasureDone
c	Finish measurement	In the user program, reset Bit 1 of the function call	In the user program, reset OutputData.LatchOrMeasure
d	Ready for new measurement	The module resets Bit 1 of the status byte	The module resets InputData.LatchOrMeasureDone

The result of the last period length measurement remains in the process image of inputs until the module signals a new measurement result by setting the status information. Before the initial measurement the process image of inputs contains 0000 0000_H or FFFF FFFF_H

The module issues the result of period length measurement in multiples of 200 ns.

Example:

- ▶ The process image of inputs contains 32_H/50_D
- ▶ The period length is 200 ns x 50 = 10 μs

4.2.5.2 Transfer counter status via latch pulse

A signal output can be connected to input L on the module for a latch pulse. The latch pulse may come from a PLC or position switch, for example. Using the latch function it is possible to record and transmit the counter status at the time of this latch pulse.

Prerequisite: This function is configured in the PSSu Configurator / PAS4000.

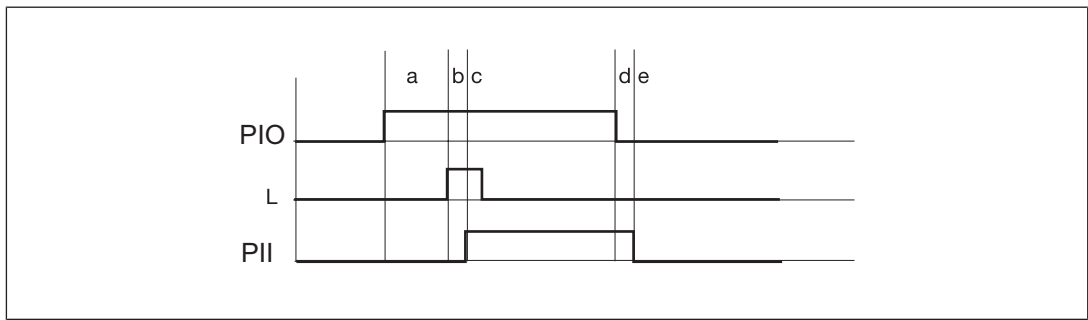

Legend:

- ▶ PIO: Bit 1 of the byte for function calls in the process image of outputs or I/O data OutputData.LatchOrMeasure
- ▶ L: Input L for external latch
- ▶ PII: Bit 1 of the status byte in the process image of inputs or I/O data InputData.LatchOrMeasureDone

Key to timing diagram:

Section	Function	Procedure for PSSu in system environment A	Procedure for PSSu in system environment B
a	Activate latch function	In the user program, set Bit 1 of the function call	In the user program, set OutputData.LatchOrMeasure
b	Fill latch memory	Rising edge at input L: Counter status is transferred to the latch memory	Rising edge at input L: Counter status is transferred to the latch memory
c	Output counter status Set status bit	Counter status is transferred to the process image of inputs The module sets Bit 1 of the status byte	Counter status is written in InputData.LatchOrPeriod The module sets InputData.LatchOrMeasureDone
d	Finish latch function	In the user program, reset Bit 1 of the function call	In the user program, reset OutputData.LatchOrMeasure

Section	Function	Procedure for PSSu in system environment A	Procedure for PSSu in system environment B
e	Ready for new latch function	The module resets Bit 1 of the status byte	The module resets Input-Data.LatchOrMeasureDone

The contents of the latch memory remains in the process image of inputs until the module signals a new memory value by setting the status information. Before the initial transfer the process image of inputs contains 0000 0000_H or FFFF FFFF_H

The module always transmits the counter status when the first latch pulse occurs after the function has started. All subsequent latch pulses are ignored until the function is completed and reset.

4.2.5.3 Transfer counter status via zero pulse

The output for the incremental encoder's zero pulse is connected to input C. An incremental encoder typically supplies one zero pulse per rotation. Using the zero pulse function it is possible to record the last counter status before the zero pulse and transmit it via the process image of inputs.



INFORMATION

In Counter operating mode, a rising edge at input C stops the counter.

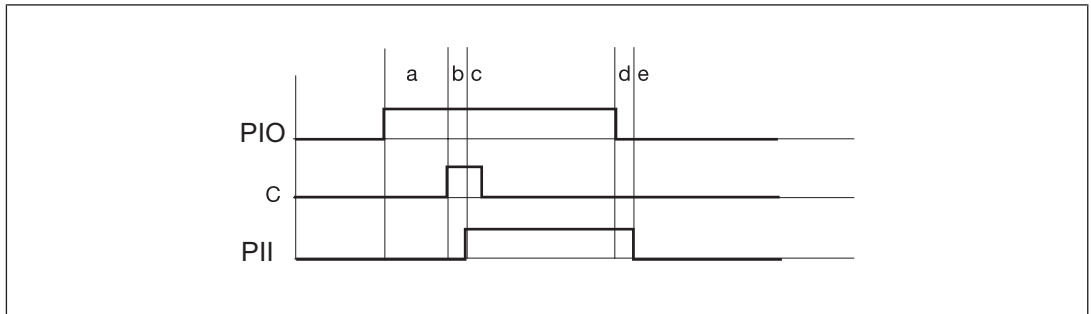

Legend:

- ▶ PIO: Bit 0 of the function call in the process image of outputs or I/O datum Output-Data.ZeroPulseActive
- ▶ C: Input C
- ▶ PII: Bit 0 of the status byte in the process image of inputs or I/O datum Input-Data.ZeroPulse

Key to timing diagram:

Section	Function	Procedure for PSSu in system environment A	Procedure for PSSu in system environment B
a	Activate zero pulse function	In the user program, set Bit 0 of the function call	In the user program, set OutputData.ZeroPulseActiv
b	Fill latch memory	Rising edge at input C: Counter status is transferred to the latch memory	Rising edge at input C: Counter status is transferred to the latch memory
c	Output counter status Set status bit	Counter status is transferred to the process image of inputs The module sets Bit 0 of the status byte	Counter status is written in InputData.LatchOrPeriod The module sets InputData.ZeroPulse
d	Finish zero pulse function	In the user program, reset Bit 0 of the function call	In the user program, reset OutputData.ZeroPulseActiv
e	Ready for new latch function	The module resets Bit 0 of the status byte	The module resets InputData.ZeroPulse

The zero pulse function has priority over the latch function and the "Period length measurement" function. If this function is activated, both the other functions are ignored, even if they have been activated.

The module always transmits the counter status when the first zero pulse occurs after the function has started. The counter statuses on all subsequent zero pulses are ignored until the function has been completed and reset.

4.2.5.4 Set counter status

The "Set counter status" function sets the counter to any value. The value is stated in the user program. The module transfers the value and continues counting from this counter status.

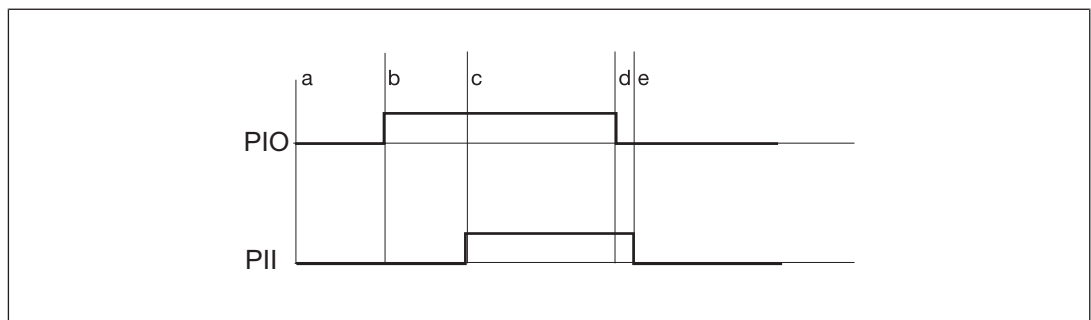

Legend:

- ▶ PIO: Bit 2 of the function call in the process image of outputs or I/O data OutputData.SetCounter
- ▶ PII: Bit 2 of the status byte in the process image of inputs or I/O data InputData.SetCounterDone

Key to timing diagram:

Section	Function	Procedure for PSSu in system environment A	Procedure for PSSu in system environment B
a	Enter counter status	In the user program, write the default counter status in the process image of outputs	In the user program, assign the default counter status to OutputData.NewCounter-Value
b	Transfer counter status	In the user program, set Bit 2 of the function call	In the user program, set OutputData.SetCounter
c	Acknowledge transfer	The module sets Bit 2 of the status byte; the underflow and overflow bits are reset	The module sets Input-Data.SetCounterDone; Input-Data.Underflow and Input-Data.Overflow are reset
d	Finish transfer	In the user program, reset Bit 2 of the function call	In the user program, reset OutputData.SetCounter
e	Ready for new function	The module resets Bit 2 of the status byte	The module resets Input-Data.SetCounterDone

4.2.5.5 Monitor limit value

The module's output O0 is switched when a limit value is reached. The status of the output ("0" or "1") is defined with a polarity bit.

The function must first be activated via an enable bit.

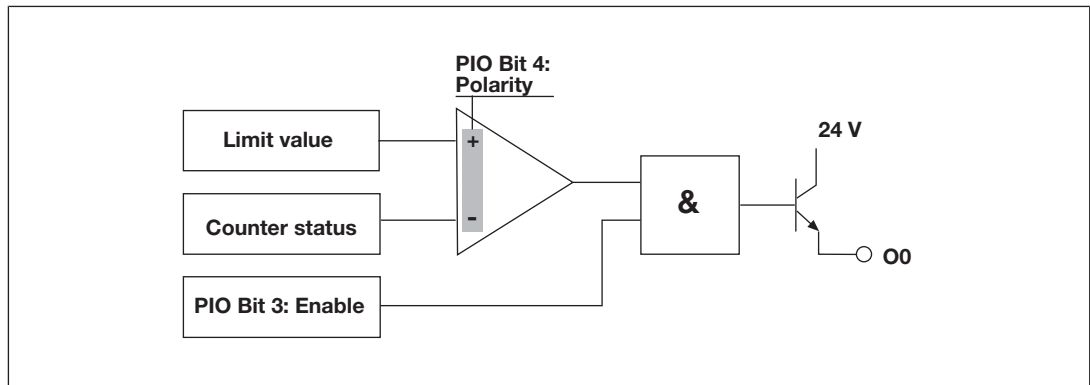

Timing diagram

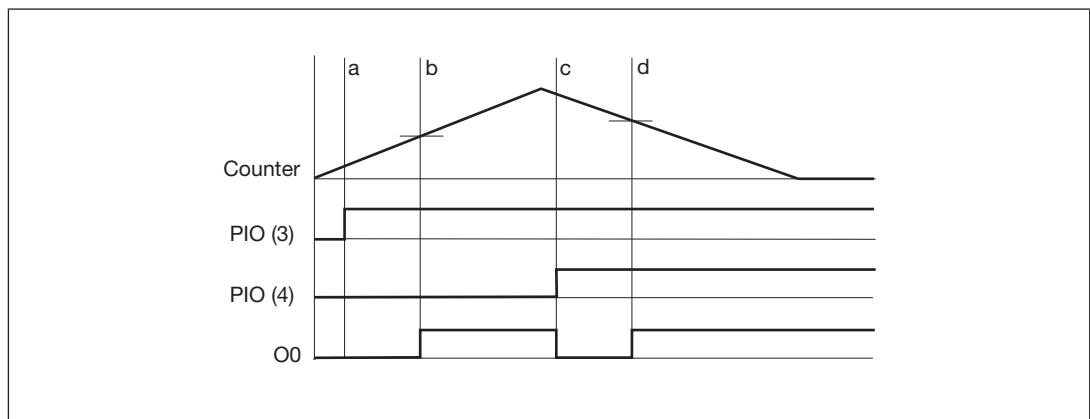

Legend:

- ▶ Counter: Count
- ▶ PIO (3): Bit 3 of the function call in the process image of outputs or I/O datum OutputData.LimitValueActive
- ▶ PIO (4): Bit 4 of the function call in the process image of outputs or I/O datum OutputData.InvertOutput
- ▶ O0: Output O0

Key to timing diagram:

Section	Function	Procedure for PSSu in system environment A	Procedure for PSSu in system environment B
a	Activate monitoring function	In the user program, set Bit 3 of the function call. Output O0 ("0" or "1") is set based on Bit 4 of the function call	In the user program, set OutputData.LimitValueActive
b	Limit value reached	Output O0 ("0" or "1") is set based on Bit 4 of the function call	Output O0 ("0" or "1") is set based on OutputData.InvertOutput
c	Output polarity changed	In the user program, set Bit 4 of the function call. Output O0 switches polarity	In the user program, set OutputData.InvertOutput. Output O0 switches polarity
d	Limit value reached	Output O0 ("0" or "1") is set based on Bit 4 of the function call	Output O0 ("0" or "1") is set based on OutputData.InvertOutput

4.3 Configuration

4.3.1 Operating modes and parameters

The module has the following configuration options:

Configuration	Default value	Meaning
Operating mode	X	Incremental encoder operating mode
		Counter operating mode
Signal for gate input	X	Input G disables at a 1 signal
		Input G disables at a 0 signal
Period length measurement or latch function	X	Latch function
		Period length measurement
Multiple evaluation	X	Quadruple evaluation
		Double evaluation
		Single evaluation
Status input	X	The status at input S is transmitted via a bit.
		The status is transmitted via two redundant bits.
		The status is transmitted via two diverse bits. ⁽¹⁾

⁽¹⁾ Transmitting the status via two bits enables simple fault detection: Two redundant bits must always be the same, two diverse bits must always be different, otherwise the transmission is faulty.



INFORMATION

Only Pilz system software should be used to change the parameters.

4.3.2 Input/output data

4.3.2.1 PSSu assignment in system environment A

In the PII the module occupies

- ▶ 32 Bits with counter data
- ▶ 32 Bits with data from the latch memory or with the result from the period length measurement
- ▶ 8 Bits with the status byte

In the PIO the module occupies

- ▶ 32 Bits with the default counter status
- ▶ 32 Bits with the limit value
- ▶ 8 Bits with function calls

Description	ST-PII bit assignment LSB ... MSB	ST-PIO bit assignment LSB ... MSB	Notes
Status byte	0 ... 7		See "Status byte assignment" table
Current counter status	8 ... 39		Measured value in incremental encoder or counter operating mode
Counter status from the latch memory or result from the period length measurement	40 ... 71		Value recorded after a latch or zero pulse or period length
Byte for function calls		0 ... 7	See table: "Overview of function calls"
Default counter status		8 ... 39	Value at which the counter is set
Specify limit value		40 ... 71	Value at which the limit value is set

Overview of function calls:

Function calls	Bit	Assignment
Transfer counter status via zero pulse	0	0: Input C (zero pulse) inactive 1: Input C (zero pulse) active
Transfer counter status via latch pulse or measure period length ⁽¹⁾	1	0: Input L (latch pulse) inactive/period length measurement inactive 1: Input L (latch pulse) active/period length measurement active
Set counter status	2	0: Do not transfer default counter status 1: Adopt default counter status
Monitor limit value	3	0: Limit value monitoring inactive 1: Limit value monitoring active
Invert output O0	4	0: Output O0 not inverted 1: Output O0 inverted
	5 ... 7	Reserved

⁽¹⁾ Whether the period length is measured or the latch pulse is evaluated, must be defined in the PSSu Configurator.

Status byte assignment:

Meaning	Bit	Assignment
Zero pulse	0	0: No zero pulse at input C 1: Zero pulse at input C
Latch pulse or period length measurement	1	0: Period length or contents of latch memory not transferred 1: Period length or contents of latch memory transferred
Default counter status	2	0: Default counter status not transferred 1: Default counter status transferred
Counter underflow	3	0: No counter underflow 1: Counter underflow
Counter overflow	4	0: No counter overflow 1: Counter overflow
Status input S, Bit 1	5	0: Status input, Bit 1 (message from encoder) 1: Status input, Bit 1
Status input S, Bit 2	6	0: Status input, Bit 2 ⁽¹⁾ 1: Status input, Bit 2
Reserved	7	-

⁽¹⁾When configuring the module, users can determine the evaluation method for the status input: single, redundant or diverse. Transmitting the status via two bits enables simple fault detection: Two redundant bits must always be the same, two diverse bits must always be different, otherwise the transmission is faulty.

4.3.2.2 PSSu assignment in system environment B

Data access is via pre-defined I/O data types:

I/O data name	I/O data type	I/O data element	Meaning
OutputData	ST_O_INC_24V	ZeroPulseActiv: BOOL	FALSE: Input C (zero pulse) inactive TRUE: Input C (zero pulse) active
		LatchOrMeasure: BOOL	FALSE: Input L (latch pulse) inactive/period length measurement inactive TRUE: Input L (latch pulse) active/period length measurement active
		SetCounter: BOOL	FALSE: Do not transfer default counter status TRUE: Adopt default counter status
		NewCounterValue: DWORD	Default counter status
		LimitValueActive: BOOL	FALSE: Limit value monitoring inactive TRUE: Limit value monitoring active
		InvertOutput: BOOL	FALSE: Output O0 not inverted TRUE: Output O0 inverted
		LimitValue: DWORD	Value at which the limit value is set

I/O data name	I/O data type	I/O data element	Meaning
InputData	ST_I_INC	CurrentData: DWORD	Current counter status in incremental encoder or counter operating mode
		LatchOrPeriod: DWORD	Counter status after a latch or zero pulse or period length
		ZeroPulse: BOOL	FALSE: No zero pulse at input C TRUE: Zero pulse at input C
		LatchOrMeasureDone: BOOL	FALSE: Period length or contents of latch memory not transferred TRUE: Period length or contents of latch memory transferred
		SetCounterDONE: BOOL	FALSE: Default counter status not transferred TRUE: Default counter status transferred
		Underflow: BOOL	FALSE: No counter underflow TRUE: Counter underflow
		Overflow: BOOL	FALSE: No counter overflow TRUE: Counter overflow
		State1: BOOL	FALSE: Status input, Bit 1 (message from encoder) TRUE: Status input, Bit 1
		State2: BOOL	FALSE: Status input, Bit 2 ⁽¹⁾ TRUE: Status input, Bit 2

⁽¹⁾ When configuring the module, users can determine the evaluation method for the status input: single, redundant or diverse. Transmitting the status via two bits enables simple fault detection: Two redundant bits must always be the same, two diverse bits must always be different, otherwise the transmission is faulty.

5 Installation

5.1 General installation guidelines

Please refer also to the PSSuniversal Installation Manual.



NOTICE

Damage due to electrostatic discharge!

Electrostatic discharge can damage components. Ensure against discharge before touching the product, e.g. by touching an earthed, conductive surface or by wearing an earthed armband.

5.1.1 Dimensions

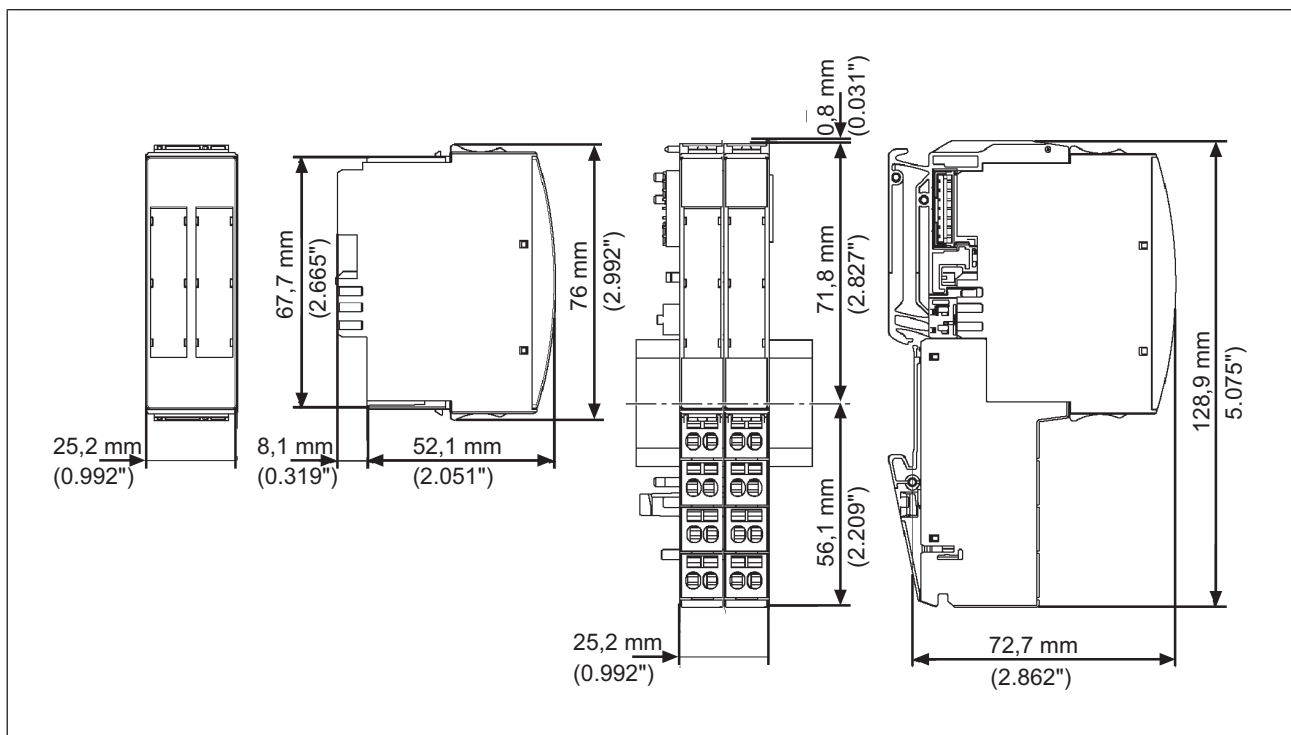

5.2 Installing the base module

Prerequisite:

- ▶ The head module must be installed.
- ▶ If the head module does not have an integrated power supply, a supply voltage module must be installed to the right of the head module.

Please note:

- ▶ For mechanical reasons it is not possible to mix base modules with screw terminals and base modules with cage clamp terminals.
- ▶ All contacts should be protected from contamination.
- ▶ The mechanics of the base modules are designed for 50 plug in/out cycles.

Procedure:

- ▶ We recommend that you wire up the base modules before inserting the electronic modules.
- ▶ Slot the groove on the base module on to the mounting rail from below [1].
- ▶ Push the base module back [2] until you hear it lock into position.
- ▶ On the mounting rail, slide the base module to the left until you hear the two lateral mounting hooks on the adjacent module lock into position [3].

Schematic representation:

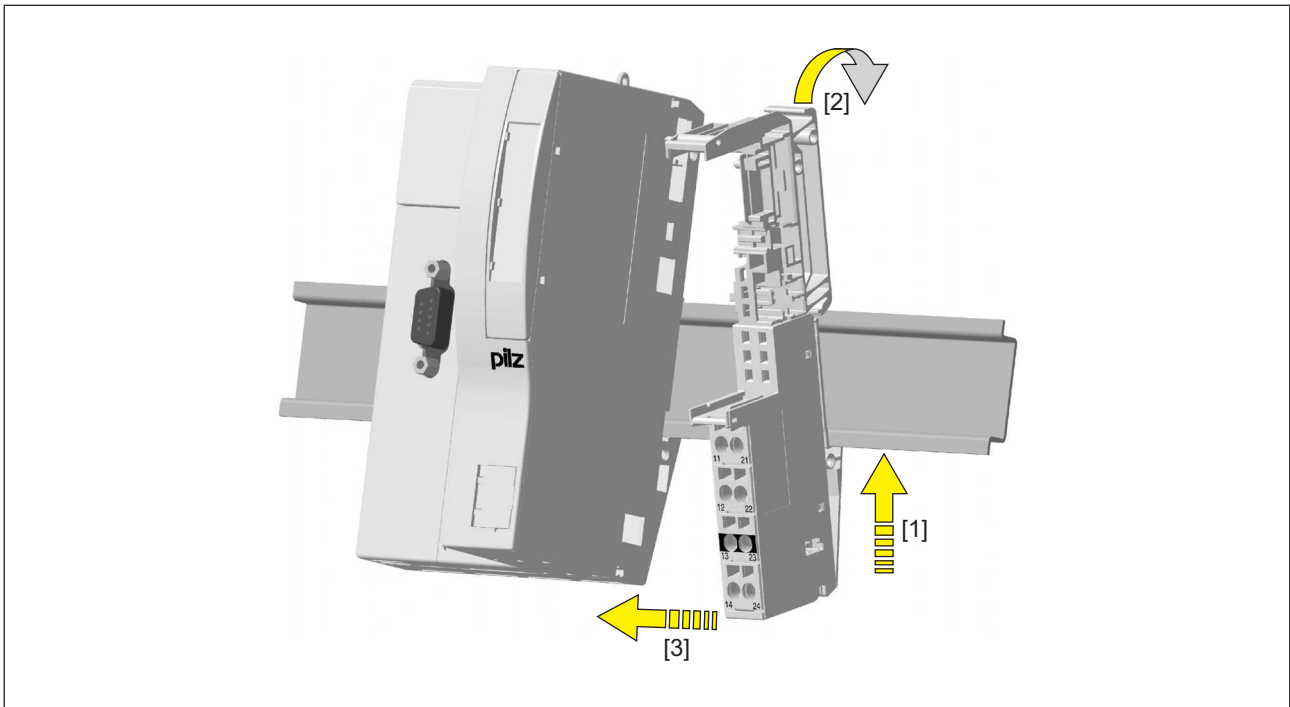

5.3 Inserting and removing an electronic module

Please note:

- ▶ Only insert on to base modules that are already installed.
- ▶ Preferably these base modules should be ready wired.
- ▶ Electronic modules with outputs may only be inserted and removed when the load is switched off. Unforeseeable error reactions may be triggered if modules are inserted and removed under load.
- ▶ When an electronic module is plugged into a base module for the first time, one part of the coding element remains on the electronic module, while its counterpart is fixed on to the base module. This is how the base module is coded.
- ▶ The mechanics of the electronic modules are designed for 50 plug in/out cycles.

5.3.1 Inserting an electronic module

Procedure:

- ▶ The electronic module must audibly lock into position [1].
- ▶ Mark the electronic module using the labelling strips [2].

Schematic representation:

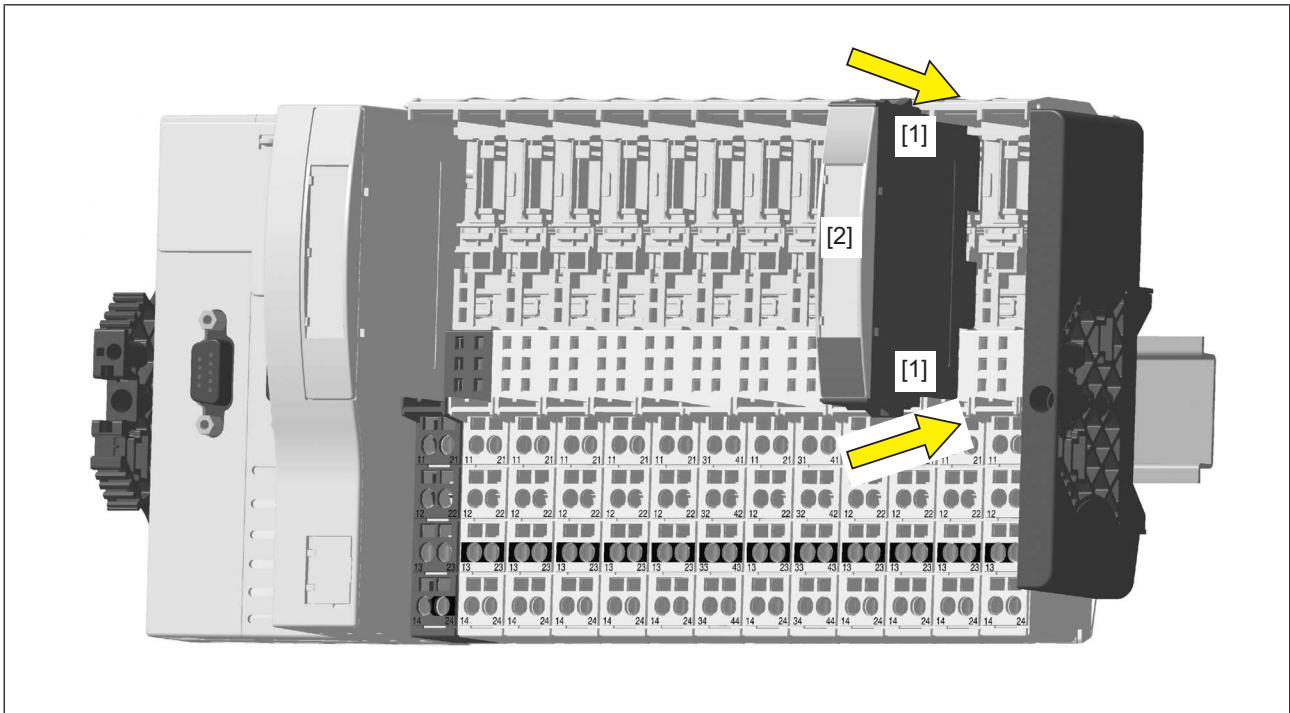

5.3.2 Removing an electronic module

Procedure:

- ▶ Press the locking mechanisms [1] together simultaneously.
- ▶ Pull out the electronic module [2].

Schematic representation:

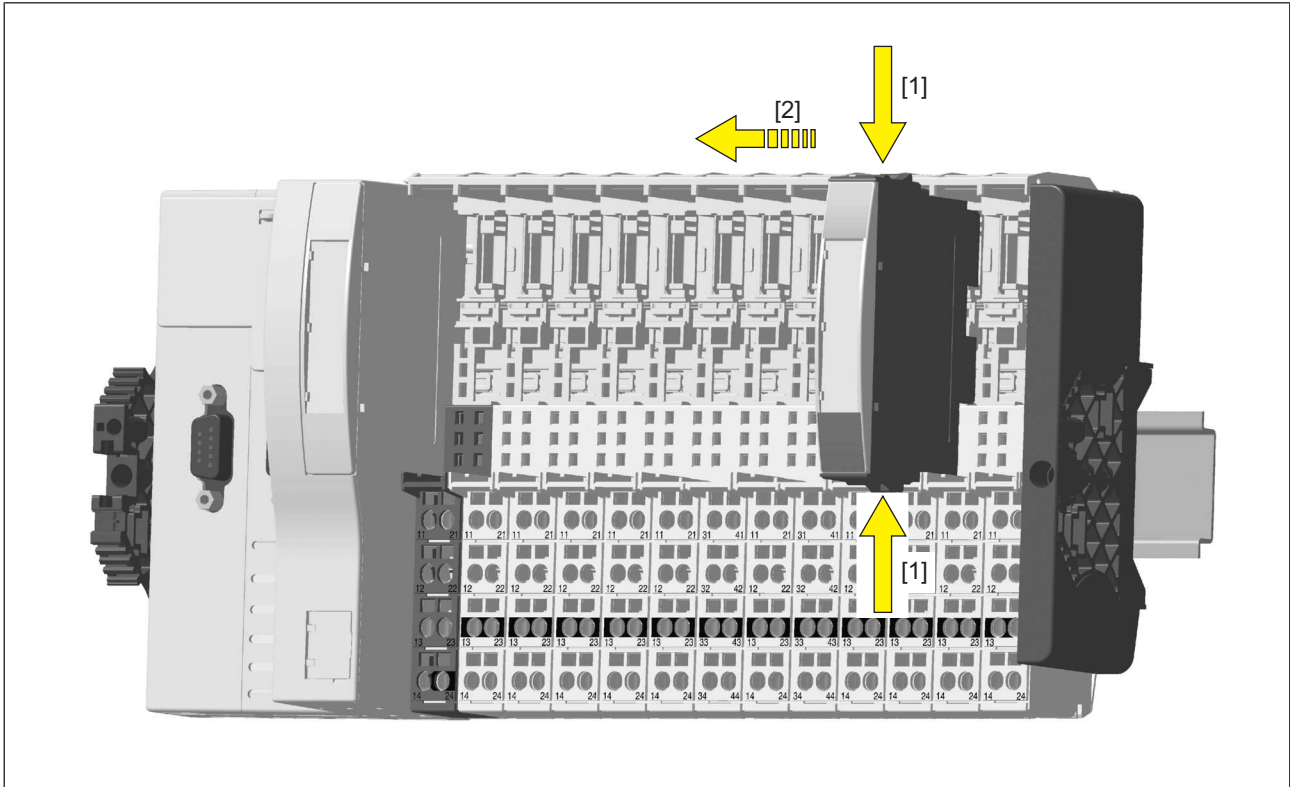

5.3.3 Changing an electronic module during operation

It is possible to change an electronic module during operation. The configuration data is retained when a module is changed.

Effects:

- ▶ System environment A:
 - In the event of a potential FS communication error, the FS section of the PSSu system and all relevant I/O-Groups (SafetyBUS p) switch to a STOP condition.
- ▶ System environment B:
 - All FS hardware outputs on the PSSu system switch to a safe condition.
 - The substitute values are used for the modules' FS outputs, with Valid Bits = FALSE.



CAUTION!

Sparking can cause interference and errors!

Only change the module when the load is switched off!

6 Wiring

6.1 General wiring guidelines

Please note:

- ▶ The module's connections are galvanically isolated from the module supply.
- ▶ The module evaluates open inputs (A, B, C) as a 0 signal.
- ▶ The module evaluates open function inputs (G, L, S) as a 0 signal.
- ▶ We recommend that you use shielded signal lines.
- ▶ On base modules with C-rail:
 - Connect the shield to the terminals on the C-rail.
 - Connect the C-rail with low impedance to the functional earth.
- ▶ On base modules without C-rail:
 - Connect the shield as shown in the terminal configuration section.
 - The module connects the shield to the functional earth via the mounting rail.
- ▶ The channel for the incremental encoder's zero pulse has a different designation depending on the manufacturer (N, C, Z, 0,...)
- ▶ The power supply must meet the regulations for extra low voltages with protective electrical separation (SELV, PELV).
- ▶ Use copper wiring.
- ▶ The terminal configuration as stated on the front plate applies for base modules with C-rail. The terminal configuration as stated in the technical documentation applies for all other base modules.

6.1.1 Mechanical connection of the base modules

Procedure:

- ▶ Use a flat blade screwdriver (DIN 5264-A)!

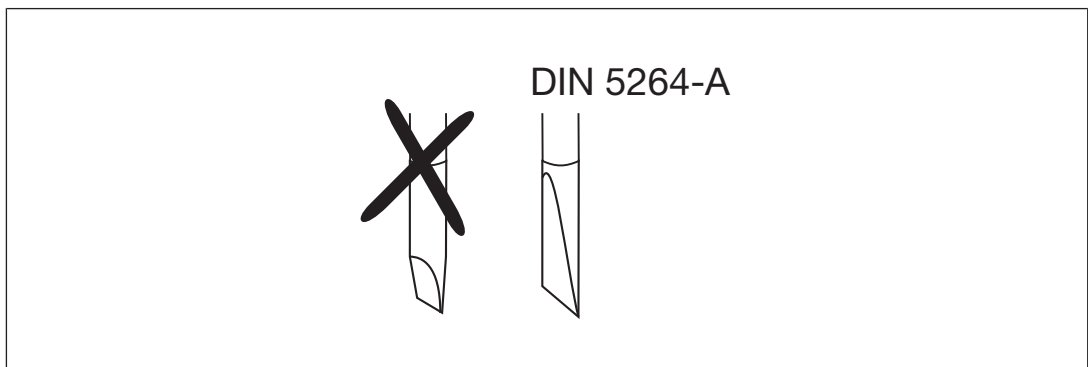

- ▶ Strip the wire back 8 mm.
- ▶ If necessary, label the connection level with a colour marker [3].
- ▶ Base module with screw terminals:
 - Use a screwdriver to loosen the screw on the screw terminal [1]
 - Insert the stripped cable into the round fixing hole [2], as far as it will go.
 - Tighten up the screw on the screw terminal.

- Check that the cable is firmly seated.
- ▶ Base module with cage clamp terminals:
 - Insert the screwdriver [4] into the square hole [1].
 - Insert the stripped cable into the round fixing hole [2], as far as it will go [5].
 - Pull out the screwdriver [6].
 - Check that the cable is firmly seated.

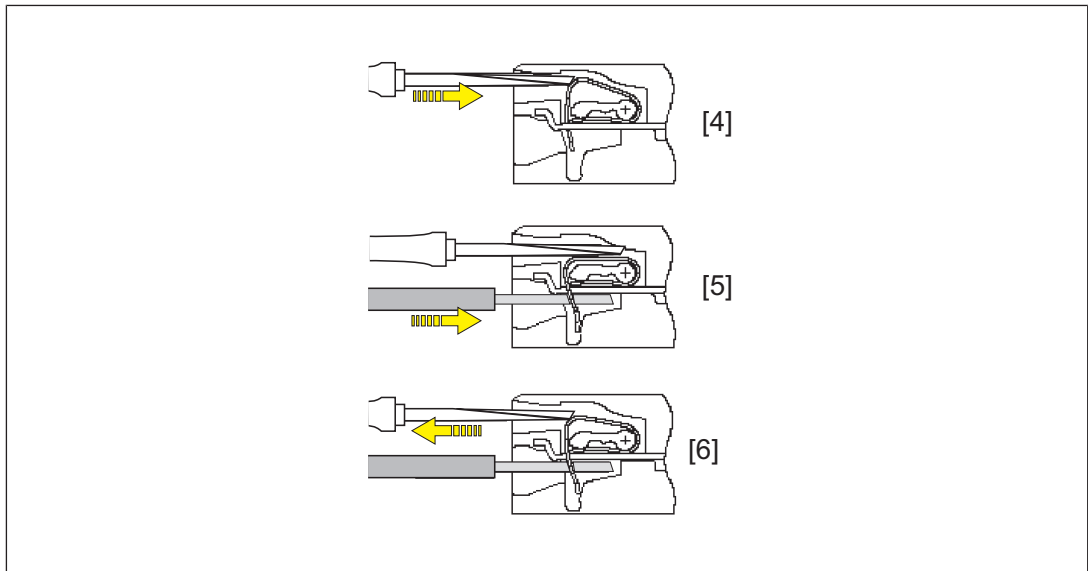
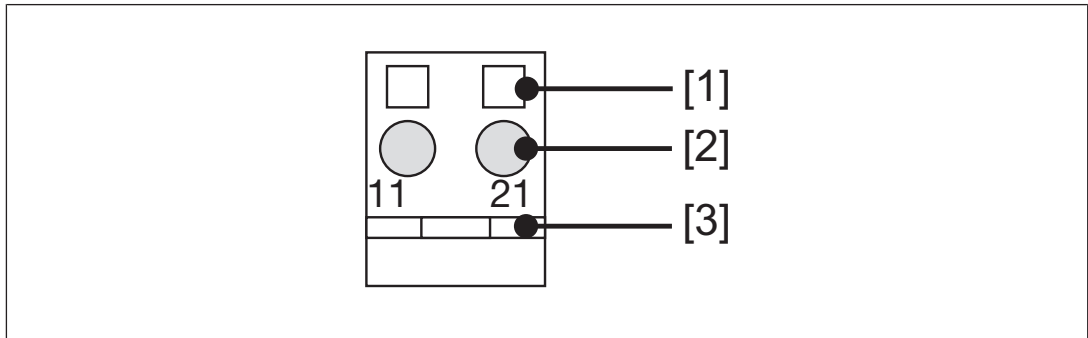



Please note:

- ▶ The minimum cable cross section for field connection terminals on the base modules is 0.14 mm² (AWG26).
- ▶ The maximum cable cross section for field connection terminals is:
 - Digital inputs: 1.5 mm² (AWG16)
 - Digital outputs: 2.0 mm² (AWG14)
 - Inputs/outputs on the counter modules: 1.5 mm² (AWG16)
 - Analogue inputs/outputs: 1.5 mm² (AWG16)
 - Communication cables: 1.5 mm² (AWG16)
 - Test pulse outputs: 1.5 mm² (AWG16)
 - Power supply: 2.5 mm² (AWG12)
 - Functional earth: 2.5 mm² (AWG12)

- ▶ On base modules with screw terminals:
 - If you use a multi-strand cable to connect the I/Os, it is recommended that you use ferrules conforming to Parts 1 and 2 of DIN 46228, 0.14 ... 1.5 mm², Form A or C, although this is not essential. To crimp the ferrules you can use crimp pliers (crimp form A or C) conforming to EN 60947-1, such as the PZ 1.5 or PZ 6.5 from Weidmüller, for example.
 - Maximum torque setting: 0.8 Nm
- ▶ Use copper wiring.

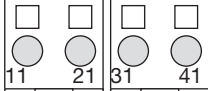
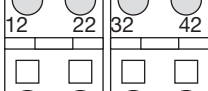
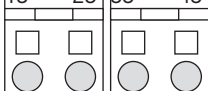
6.2 Terminal configuration

Base module	Terminal configuration	
Screw terminals: PSSu BP 2/16 S PSSu BP 2/16 S-T	Without C-rail: 11: Input A	
Cage clamp terminals: PSSu BP 2/16 C PSSu BP 2/16 C-T	21: Input B	
	31: Input C	
	41: Input G (Gate)	
	12-22: 0 V encoder (12-22 linked within the base module)	
	32-42: Input S (Status) (32-42 linked within the base module)	
	13-23-33-43: Shield connection (13-23-33-43 linked within the base module)	
	14-24: Supply voltage output for encoder	
	34: Output for limit value monitoring	
	44: Input L (Latch)	

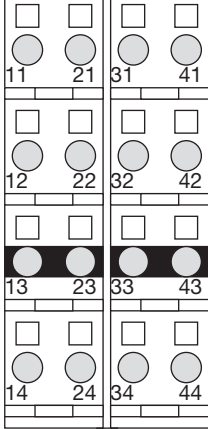
Base module	Terminal configuration	
<p>Screw terminals: PSSu BP-C 2/16 S PSSu BP-C 2/16 S-T</p> <p>Cage clamp terminals: PSSu BP-C 2/16 C PSSu BP-C 2/16 C-T</p>	<p>With C-rail:</p> <p>11: Input A</p> <p>21: Input B</p> <p>31: Input C</p> <p>41: Input G (Gate)</p> <p>12-22: 0 V encoder (12-22 linked within the base module)</p> <p>32-42: Input S (Status) (32-42 linked within the base module)</p> <p>13-23-33-43: C-rail supply shield connection (13-23-33-43 linked within the base module)</p> <p>14-24: Supply voltage output for encoder</p> <p>34: Output for limit value monitoring</p> <p>44: Input L (Latch)</p>	

6.3 Connecting the module

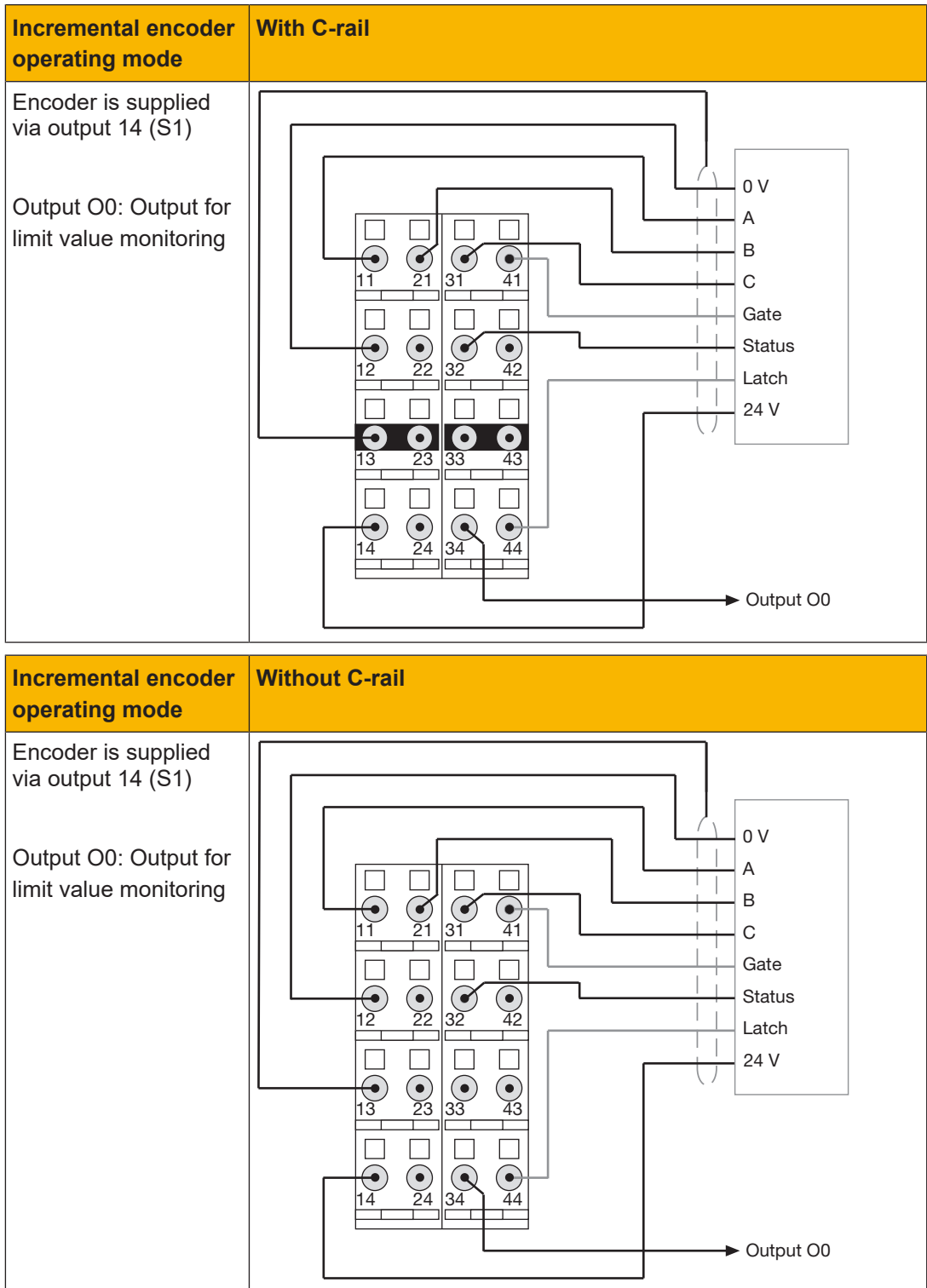

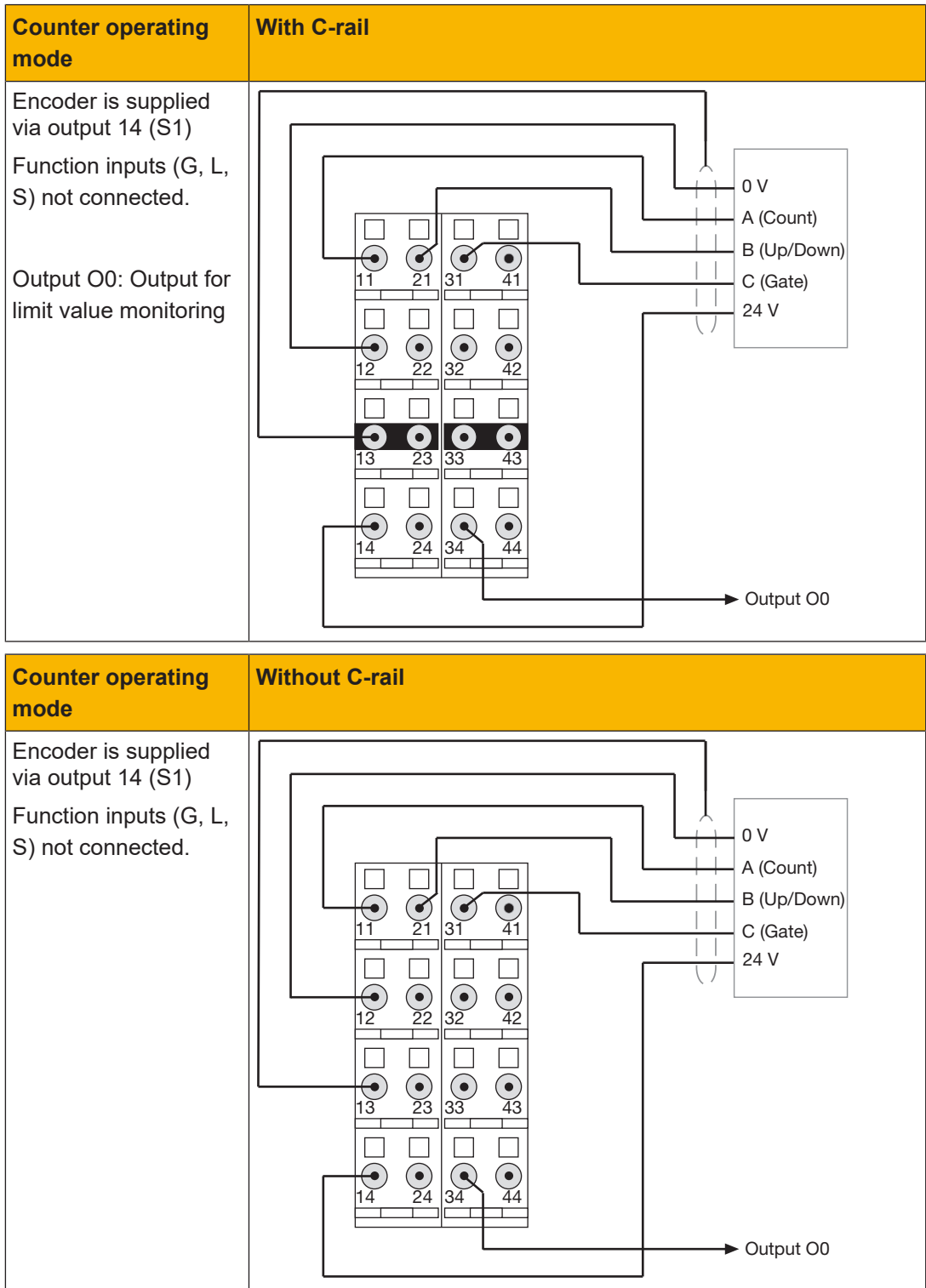

7 Operation

7.1 Messages

A module error is displayed via the "Err" LED (see section entitled "Display elements"). It is signalled to the head module and then entered in the

- ▶ Error stack, with PSSu in system environment A
- ▶ Diagnostic log, with PSSu in system environment B.



of the head module.

The module can detect the following errors:

Module error	Statement	Remedy
Start-up error	Error as the PSSu system starts up	Change faulty module.
Configuration error	Incorrect module type configured.	The configured hardware registry does not match the actual hardware registry.
ST communication error	Error during ST communication	Change faulty module.
Bus termination error	There is no terminating plate or there is a bad contact with the module bus.	Install a terminating plate with integrated end bracket or insert the base modules together correctly.
Supply voltage overload for encoder	Supply voltage for encoder overloaded or short-circuited	Rectify overload or short circuit



7.2 Display elements

Legend

-  LED on
-  LED off

7.2.1 Display elements for module diagnostics

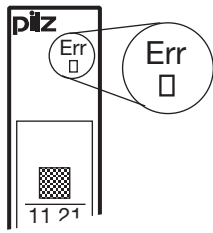
The module has an LED for displaying module errors ("Err" LED).

	LED			Meaning
	Name	Colour	Status	
	Err	---		No error
	Red		Module error	

7.2.2 Display elements for counter status

The module has three LEDs for the status of the counter inputs (LEDs "A", "B" and "C").

	LED			Key
	Name	Colour	Status	Signal
	A	---	●	0 signal at counter input A
		green	☀	1 signal at counter input A
	B	---	●	0 signal at counter input B
		green	☀	1 signal at counter input B
C	---	●	0 signal at counter input C	
	green	☀	1 signal at counter input C	

7.2.3 Display elements for status of the functional inputs

The module has three LEDs for the status of the function inputs (LEDs "G", "L" and "S").

	LED			Key
	Description	Colour	Status	Signal
	G	---	●	0 signal at function input G
		Green	☀	1 signal at function input G
	L	---	●	0 signal at function input L
		Green	☀	1 signal at function input L
S	---	●	0 signal at function input S	
	Green	☀	1 signal at function input S	

7.3 Status information

The way in which status information is assigned to the status byte and I/O data is described in the chapter entitled "Function Description", under "Input/output data".

8 Technical details

General	312486	314486
Certifications	CE, TÜV, UKCA, cULus Listed	CE, TÜV, UKCA, cULus Listed
Application range	Standard	Standard
Module's device code	0322h	0322h
Number of ST input bits	64	64
Number of ST output bits	64	64
Number of ST status bits	8	8
Number of ST control bits	8	8
Application in system environment A		
from ST firmware version, other head modules	18	18
from ST firmware version PSSu H S PN	3	3
Application in system environment B		
from ST firmware version, head modules	1.7.0	1.7.0
Electrical data	312486	314486
Internal supply voltage (module supply)		
Module's power consumption	0,85 W	0,85 W
Periphery's supply voltage (peri- phery supply)		
Voltage range	16,8 - 30 V	16,8 - 30 V
Module's current consumption with no load	10 mA	10 mA
Module's power consumption with no load	0,24 W	0,24 W
Max. power dissipation of module	1,4 W	1,4 W
Incremental encoder input	312486	314486
Number of counter inputs	1	1
Type of counter inputs	Incremental encoder	Incremental encoder
Signal at counter inputs A and B and/or C	single-ended (HTL)	single-ended (HTL)
Permitted low signal range on LATCH/GATE/STATUS signals	-3 - 5 V	-3 - 5 V
Permitted high signal range on LATCH/GATE/STATUS signals	11 - 30 V	11 - 30 V
Typ. input current of the LATCH and/or GATE and/or STATUS sig- nals at low level	0 mA	0 mA
Typ. input current of the LATCH and/or GATE and/or STATUS sig- nals at high level	4 mA	4 mA

Incremental encoder input	312486	314486
Max. number of bits on the counter input	32 Bit	32 Bit
Evaluation of counter pulses	1x, 2x, 4x	1x, 2x, 4x
Phase offset between differential signals A and B	90 deg	90 deg
Phase offset tolerance	30 deg	30 deg
Maximum cutoff frequency	0,2 MHz	0,2 MHz
Time constant of input filter on LATCH signal	50 µs	50 µs
Time constant of input filter on GATE signal	50 µs	50 µs
Time constant of input filter on STATUS signal	50 µs	50 µs
Typ. processing time	0,1 ms	0,1 ms
Potential isolation between input/output and periphery supply	No	No
Potential isolation between input/output and voltage for the internal module bus	Yes	Yes
Semiconductor outputs	312486	314486
Rated voltage	24 V DC	24 V DC
Max. output current at rated voltage	0,5 A	0,5 A
Voltage outputs	312486	314486
Rated voltage	24 V DC	24 V DC
Max. output current at rated voltage	0,1 A	0,1 A
Environmental data	312486	314486
Climatic suitability	EN 60068-2-1, EN 60068-2-14, EN 60068-2-2, EN 60068-2-30, EN 60068-2-78	EN 60068-2-1, EN 60068-2-14, EN 60068-2-2, EN 60068-2-30, EN 60068-2-78
Ambient temperature		
in accordance with the standard	EN 60068-2-14	EN 60068-2-14
Temperature range	0 - 60 °C	-40 - 70 °C
Storage temperature		
in accordance with the standard	EN 60068-2-1/-2	EN 60068-2-1/-2
Temperature range	-25 - 70 °C	-40 - 70 °C
Climatic suitability		
in accordance with the standard	EN 60068-2-30, EN 60068-2-78	EN 60068-2-30, EN 60068-2-78
Humidity	93 % r. h. at 40 °C	93 % r. h. at 40 °C
Condensation during operation	Not permitted	Short-term
Max. operating height above SL	2000 m	5000 m
EMC	EN 61000-4-2, EN 61000-4-3, EN 61000-4-4, EN 61000-4-5, EN 61000-4-6, EN 61000-6-2, EN 61000-6-4	EN 61000-4-2, EN 61000-4-3, EN 61000-4-4, EN 61000-4-5, EN 61000-4-6, EN 61000-6-2, EN 61000-6-4

Environmental data	312486	314486
Vibration		
in accordance with the standard	EN 60068-2-6	EN 60068-2-6
Frequency	10 - 150 Hz	10 - 1000 Hz
Amplitude	0,35 mm	0,35 mm
Acceleration	1g	5g
Broadband noise		
in accordance with the standard	–	EN 60068-2-64
Frequency	–	5 - 500 Hz
Acceleration	–	1,9grms
Shock stress		
in accordance with the standard	EN 60068-2-27	EN 60068-2-27
Number of shocks	6	6
Acceleration	15g	15g
Duration	11 ms	11 ms
in accordance with the standard	EN 60068-2-27	EN 60068-2-27
Number of shocks	1000	1000
Acceleration	10g	25g
Duration	16 ms	6 ms
Airgap creepage		
in accordance with the standard	EN 60664-1	EN 60664-1
Overvoltage category	II	II
Pollution degree	2	2
Protection type		
in accordance with the standard	EN 60529	EN 60529
Housing	IP20	IP20
Terminals	IP20	IP20
Mounting area (e.g. control cabinet)	IP54	IP54
Mechanical data	312486	314486
Material		
Bottom	PC	PC
Front	PC	PC
Coding	PA	PA
Mounting type	plug-in	plug-in
Dimensions		
Height	76 mm	76 mm
Width	25,2 mm	25,2 mm
Depth	60,2 mm	60,2 mm
Weight	45 g	48 g
Mechanical coding		
Type	M	M
Colour	Dark grey	Dark grey

Where standards are undated, the 2005-04 latest editions shall apply.

9 Supplementary data

9.1 Permitted operating height

The values stated in the technical details apply to the use of the device in operating heights up to max. 2000 m above SL. When used at higher levels, restrictions of the ambient temperature (standard IEC 61131-2) must be taken into account.

Operating height above SL [m]	Multiplication factors for the devices' ambient temperature
0 ... 2000	1.0
3000	0.9
4000	0.8
5000	0.7

10 Order reference

10.1 Product

Product type	Features	Order no.
PSSu E S INC 24V se	Electronic module	312486
PSSu E S INC 24V se-T	Electronic module, T-type	314486

10.2 Accessories

Base modules

Product type	Features	Order no.
PSSu BP 2/16 S	Base module without C-rail with screw terminals	312628
PSSu BP 2/16 S-T	Base module without C-rail with screw terminals, T-type	314628
PSSu BP 2/16 C	Base module without C-rail with cage clamp terminals	312629
PSSu BP 2/16 C-T	Base module without C-rail with cage clamp terminals, T-type	314629
PSSu BP-C 2/16 S	Base module with C-rail and screw terminals	312630
PSSu BP-C 2/16 S-T	Base module with C-rail and screw terminals, T-type	314630
PSSu BP-C 2/16 C	Base module with C-rail and cage clamp terminals	312631
PSSu BP-C 2/16 C-T	Base module with C-rail and cage clamp terminals, T-type	314631

Support

Technical support is available from Pilz round the clock.

Americas

Brazil

+55 11 97569-2804

Canada

+1 888 315 7459

Mexico

+52 55 5572 1300

USA (toll-free)

+1 877-PILZUSA (745-9872)

Asia

China

+86 400-088-3566

Japan

+81 45 471-2281

South Korea

+82 31 778 3300

Australia and Oceania

Australia

+61 3 95600621

New Zealand

+64 9 6345350

Europe

Austria

+43 1 7986263-444

Belgium, Luxembourg

+32 9 3217570

France

+33 3 88104003

Germany

+49 711 3409-444

Ireland

+353 21 4804983

Italy, Malta

+39 0362 1826711

Scandinavia

+45 74436332

Spain

+34 938497433

Switzerland

+41 62 88979-32

The Netherlands

+31 347 320477

Türkiye

+90 216 5775552

United Kingdom

+44 1536 462203

You can reach our international hotline on:

+49 711 3409-222

support@pilz.com

Pilz develops environmentally-friendly products using ecological materials and energy-saving technologies. Offices and production facilities are ecologically designed, environmentally-aware and energy-saving. So Pilz offers sustainability, plus the security of using energy-efficient products and environmentally-friendly solutions.



CECE[®], CHRE[®], CMSE[®], INDUSTRIAL P[®], Leansafe[®], Myzel[®], PAS4000[®], PASscal[®], PASconfig[®], Pilz[®], PIT[®], PMSprimo[®], PMSprotego[®], PMCiendo[®], PMD[®], PME[®], PNOZ[®], Primo[®], PSEN[®], PSS[®], PSS[®], PVIS[®], SafetyBUS p[®], SafetyNET p[®], THE SPIRIT OF SAFETY[®] are registered and protected trademarks of Pilz GmbH & Co. KG in some countries. We would point out that product features may vary from the details stated in this document, depending on the status at the time of publication and the scope of the equipment. We accept no responsibility for the validity, accuracy and entirety of the text and graphics presented in this information. Please contact our Technical Support if you have any questions.

1001380-EN-06, 2024-10 Printed in Germany
© Pilz GmbH & Co. KG, 2019

We are represented internationally. Please refer to our homepage www.pilz.com for further details or contact our headquarters.

Headquarters: Pilz GmbH & Co. KG, Felix-Wankel-Straße 2, 73760 Ostfildern, Germany
Telephone: +49 711 3409-0, E-Mail: info@pilz.com, Internet: www.pilz.com

PILZ
THE SPIRIT OF SAFETY