



## ► PSS u2 P0 F/S PN

# PILZ

THE SPIRIT OF SAFETY

Operating Manual-1003986-EN-10

- Remote I/O system PSS u2



This document is the original document.

Where unavoidable, for reasons of readability, the masculine form has been selected when formulating this document. We do assure you that all persons are regarded without discrimination and on an equal basis.

All rights to this documentation are reserved by Pilz GmbH & Co. KG. Copies may be made for the user's internal purposes. Suggestions and comments for improving this documentation will be gratefully received.

Pilz®, PIT®, PMI®, PNOZ®, Primo®, PSEN®, PSS®, PVIS®, SafetyBUS p®, SafetyEYE®, SafetyNET p®, the spirit of safety® are registered and protected trademarks of Pilz GmbH & Co. KG in some countries.



SD means Secure Digital

<b>1</b>	<b>Introduction</b>	<b>5</b>
1.1	Validity of documentation	5
1.2	Using the documentation	5
1.3	Third-party manufacturer licence information	5
1.4	Definition of symbols	5
<b>2</b>	<b>Overview</b>	<b>7</b>
2.1	Module features	7
2.2	Front view	8
2.3	Scope of supply	8
<b>3</b>	<b>Safety</b>	<b>9</b>
3.1	Intended use	9
3.2	System requirements	9
3.3	Safety regulations	10
3.3.1	Safety assessment	10
3.3.2	Use of qualified personnel	10
3.3.3	Warranty and liability	10
3.3.4	Disposal	10
<b>4</b>	<b>Function description</b>	<b>11</b>
4.1	Block diagram	11
4.2	Supply voltage	11
4.3	Integrated protection mechanisms	12
4.4	MicroSD card	12
4.5	Reset button	12
4.6	PROFINET	13
4.6.1	Connection to PROFINET	13
4.6.2	MAC addresses	14
4.6.3	PROFIsafe groups	14
4.6.4	Setting the F-address	15
4.6.5	Deactivation and reactivation	15
4.6.6	Projects	16
4.6.7	PROFIenergy	16
4.7	System reaction times	17
4.8	Substitute values	18
<b>5</b>	<b>Installation</b>	<b>19</b>
5.1	General installation guidelines	19
5.2	Dimensions in mm	20
5.3	Installing the head module	21
<b>6</b>	<b>Interfaces</b>	<b>22</b>
<b>7</b>	<b>Wiring</b>	<b>24</b>
7.1	General wiring guidelines	24
7.2	Connecting the module	25

<b>8</b>	<b>Operation</b> .....	<b>27</b>
8.1	Display elements.....	27
8.1.1	MS.....	27
8.1.2	PWR.....	28
8.1.3	MBUS.....	28
8.1.4	SD.....	28
8.1.5	X3, X4.....	28
8.1.6	RUN and DIAG.....	29
8.1.7	SO.....	29
<b>9</b>	<b>Technical Details</b> .....	<b>30</b>
9.1	Safety characteristic data.....	32
<b>10</b>	<b>Order reference</b> .....	<b>33</b>
10.1	Accessories.....	33
<b>11</b>	<b>EC declaration of conformity</b> .....	<b>34</b>
<b>12</b>	<b>UKCA-Declaration of Conformity</b> .....	<b>35</b>

# 1 Introduction

## 1.1 Validity of documentation

This operating manual explains the function and operation, describes the installation and provides guidelines on how to connect the product.

This documentation is valid for the product PSS u2 P0 F/S PN hardware version 3.0 or higher. It is valid until new documentation is published.

## 1.2 Using the documentation

This document is intended for instruction. Only install and commission the product if you have read and understood this document. The document should be retained for future reference.

Please refer to the PSS u2 Installation Manual.

## 1.3 Third-party manufacturer licence information

The head modules include Open Source software with various licences.

Further information is available in the document "Third-party manufacturer licence information PSS u2 P0 F/S PN" (document number 1006249) at [www.pilz.com](http://www.pilz.com).

## 1.4 Definition of symbols

Information that is particularly important is identified as follows:



### **DANGER!**

This warning must be heeded! It warns of a hazardous situation that poses an immediate threat of serious injury and death and indicates preventive measures that can be taken.



### **WARNING!**

This warning must be heeded! It warns of a hazardous situation that could lead to serious injury and death and indicates preventive measures that can be taken.



### **CAUTION!**

This refers to a hazard that can lead to a less serious or minor injury plus material damage, and also provides information on preventive measures that can be taken.



**NOTICE**

This describes a situation in which the product or devices could be damaged and also provides information on preventive measures that can be taken. It also highlights areas within the text that are of particular importance.



**INFORMATION**

This gives advice on applications and provides information on special features.

## 2 Overview

### 2.1 Module features

Application of the product PSS u2 P0 F/S PN:

Head module to connect the system to PROFINET with PROFIsafe profile. The head module can be connected to an IO controller as an IO device.

The product has the following features:

- ▶ **PROFINET** interface with PROFIsafe profile
- ▶ PROFINET Conformance Class C
- ▶ IRT/RT
- ▶ Data set I&M 0-4 (only the data set I&M 0 is supported for the electronic modules)
- ▶ PROFIenergy together with all the ST modules
- ▶ LEDs for:
  - System status
  - **PROFINET** status
  - **PROFIsafe** status
  - Energy saving mode
  - Module bus
  - Diagnostics
- ▶ Electronic modules that can be used for input/output:
  - Digital failsafe modules (PSS u2 EF...)
  - All standard modules (PSS u2 ES...)

## 2.2 Front view

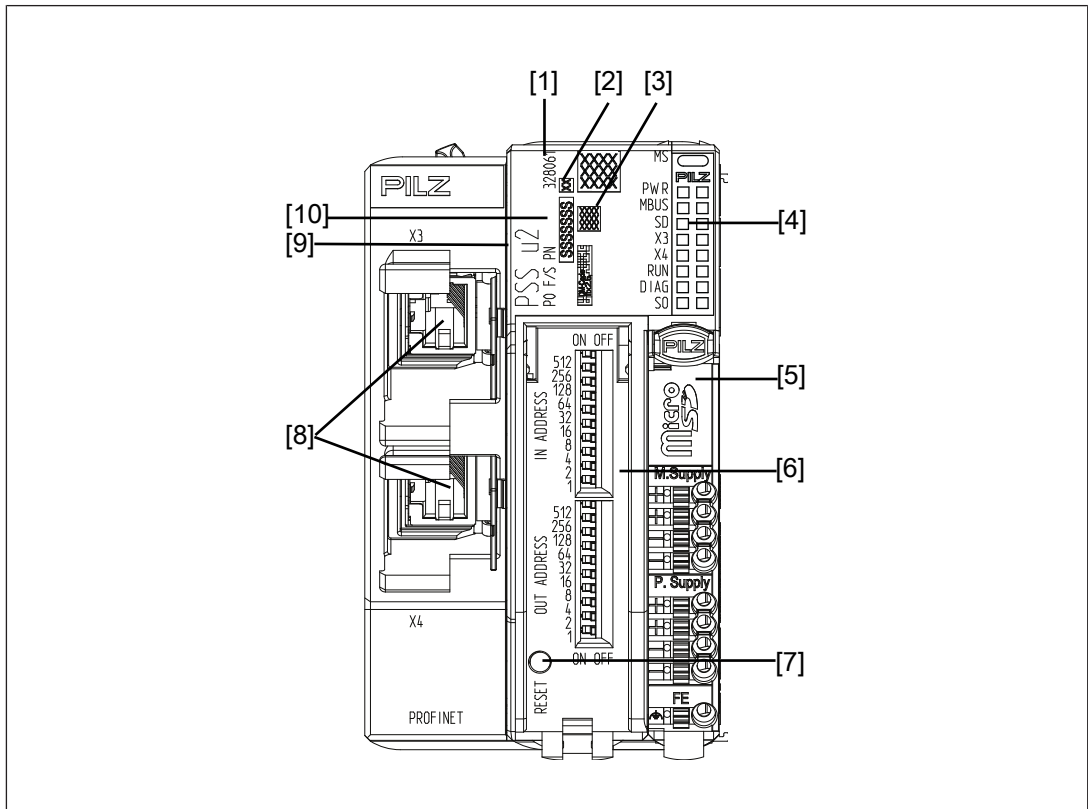

Fig.: Front view PSS u2 P0 F/S PN

### Legend

- 1 Order number
- 2 Hardware version
- 3 Devices MAC address
- 4 LED to display the device status and PROFINET status
- 5 Terminal block for connecting the supply voltages (supplied with the device)
- 6 DIP switch for setting the F-address for the FS inputs and FS outputs
- 7 Reset button for restart
- 8 PROFINET interface X3 and X4: RJ45 socket
- 9 Product name
- 10 Serial number

## 2.3 Scope of supply

- ▶ Head module PSS u2 P0 F/S PN with:
  - 1 x Terminal block 9-pin

## 3 Safety

### 3.1 Intended use

The module PSS u2 P0 F/S PN may only be used in the PSS u2 system.

The module is designed for use in:

- ▶ Safety-related applications with
  - **PROFINET** with PROFI-safe profile
- ▶ Non-safety-related applications with
  - **PROFINET**

The module meets the requirements of EN IEC 61508 up to SIL CL 3.

The module can be used in furnaces in accordance with EN 298.

Please note:

- ▶ To protect against transient power failures (EN 61000-4-11) the AC power supply used for the system must meet a secondary buffering for 30 ms.

Intended use includes making the electrical installation EMC-compliant. The module is designed for use in an industrial environment. Interference may occur if used in other areas.

The following is deemed improper use in particular

- ▶ Any component, technical or electrical modification to the module,
- ▶ Use of the module outside the areas described in this manual,
- ▶ Any use of the module that is not in accordance with the technical details.

Please also refer to the PROFINET guidelines issued by the "PROFIBUS User Group".

### 3.2 System requirements



#### INFORMATION

The module is supported by

- ▶ PASconfig from version 4.0.0
  - We recommend that you always use the latest version (download from [www.pilz.com](http://www.pilz.com)).

## **3.3 Safety regulations**

### **3.3.1 Safety assessment**

Before using a device it is necessary to perform a safety assessment in accordance with the Machinery Directive.

Functional safety is guaranteed for the product as a single component. However, this does not guarantee the functional safety of the overall plant/machine. In order to achieve the required safety level for the overall plant/machine, define the safety requirements for the plant/machine and then define how these must be implemented from a technical and organisational standpoint.

### **3.3.2 Use of qualified personnel**

The products may only be assembled, installed, programmed, commissioned, operated, maintained and decommissioned by competent persons.

A competent person is a qualified and knowledgeable person who, because of their training, experience and current professional activity, has the specialist knowledge required. To be able to inspect, assess and operate devices, systems and machines, the person has to be informed of the state of the art and the applicable national, European and international laws, directives and standards.

It is the company's responsibility only to employ personnel who

- ▶ Are familiar with the basic regulations concerning health and safety / accident prevention,
- ▶ Have read and understood the information provided in the section entitled Safety
- ▶ Have a good knowledge of the generic and specialist standards applicable to the specific application.

### **3.3.3 Warranty and liability**

All claims to warranty and liability will be rendered invalid if

- ▶ The product was used contrary to the purpose for which it is intended,
- ▶ Damage can be attributed to not having followed the guidelines in the manual,
- ▶ Operating personnel are not suitably qualified,
- ▶ Any type of modification has been made (e.g. exchanging components on the PCB boards, soldering work etc.).

### **3.3.4 Disposal**

- ▶ In safety-related applications, please comply with the mission time  $T_M$  in the safety-related characteristic data.
- ▶ When decommissioning, please comply with local regulations regarding the disposal of electronic devices (e.g. Electrical and Electronic Equipment Act).

## 4 Function description

### 4.1 Block diagram

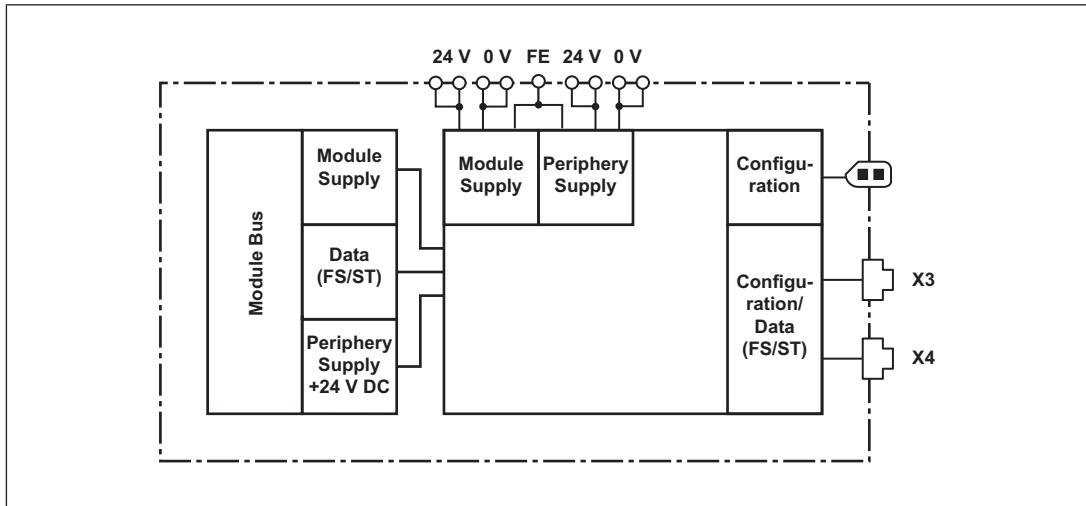

Fig.: Block diagram PSS u2 P0 F/S PN

### 4.2 Supply voltage

- ▶ Module supply
  - Supplies voltage to the head module.
  - Supplies voltage to downstream modules (right-hand side)
- ▶ Periphery supply
  - Supplies voltage to the sensors, actuators and test pulses

When the supply voltage is fed in separately, the module supply and periphery supply are galvanically isolated. If galvanic isolation is not required, a common power supply may be used for the periphery supply and module supply.

Ensure you comply with the maximum output power of the module supply and periphery supply (see "[Technical details](#) [[30](#)]"). If the power consumption is higher, an additional supply voltage module is required to refresh the periphery supply. The module supply cannot be refreshed.

- ▶ Module supply
  - The total power consumption of all backplanes and electronic modules must be  $\leq$  the maximum output power.

- ▶ Periphery supply
  - The total power consumption of the sensors, actuators and test pulses supplied via the input/output modules must be  $\leq$  the maximum output power.

If the periphery supply is missing, the "PWR" LED flashes and a message is entered in the diagnostic list.

## 4.3 Integrated protection mechanisms

The module has the following protection mechanisms:

- ▶ Multi-channel diverse processor section
- ▶ Cyclical self tests
- ▶ Potentially isolated **PROFINET** interface

Buffering:

Module supply failures are buffered for 20 ms.

## 4.4 MicroSD card

If you use the optional removable data medium, then data that is relevant for the device exchange will be stored on the data medium.



### NOTICE

The microSD card includes safety data. Ensure that the microSD card is plugged in before commissioning. After commissioning, use PASconfig to check the FS check sum of the system on the microSD card. It has to match to the FS check sum of the configured system. To ensure that final data are stored on the data medium, do not remove the microSD card before completing the checking.

When a device is changed, the stored data can be copied over using the Reset button (see Reset button).

## 4.5 Reset button

### Carrying out a warm reset (restart)

Procedure:

- ▶ Press the Reset pushbutton for less than 5 seconds.

Performing a cold start/reboot command initiates the following procedure:

- ▶ Processing is aborted
  - All LEDs apart from the "PWR" LED are shut down
- ▶ System is initialised
  - Head module is ready for operation and the "MS" LED flashes green
- ▶ System switches to "Operational" state
  - Head module is in operation and the "MS" LED lights up green
- ▶ Operational entry in the error stack

Impact after a restart:

- ▶ Inputs retain their current input values
- ▶ Substitute values are used for the outputs until the connection to the controller has been re-established.

### **Copying the device project from the removable data medium to the PSS u2 system**

#### Prerequisites

- ▶ A removable data medium must be plugged into the PSS u2 system.
- ▶ The removable data medium may not be empty or defective.
- ▶ The device project on the removable data medium must match the product type.

#### Procedure:

- ▶ Press the Reset pushbutton for more than 5 seconds. The SD LED flashes yellow.
- ▶ Release the Reset pushbutton, then press and release it again within 10 seconds.
- ▶ The device project will be copied from the removable data medium to the device.

If the required files are not on the removable data medium, the device exchange scenario is not performed and an entry is written in the error stack.

If no removable data medium is inserted, an original reset is performed.

#### Effects of the original reset:

- ▶ ST and FS configuration data is deleted
- ▶ Profinet Factory Reset is performed
- ▶ Error stack is not deleted
- ▶ The head module is restarted automatically.

## **4.6 PROFINET**

### **4.6.1 Connection to PROFINET**

#### Decentralised input/output

- ▶ The head module enables the PSS u2 to be used as a modular, decentralised input/output module.
- ▶ The head module receives signals from a higher level control system; it processes these signals and passes them on to the connected input/output modules.
- ▶ The head module receives signals from the connected input/output modules; it processes these signals and passes them on to a higher level control system.

#### Interfaces:

- ▶ PROFINET interface
  - The PROFINET interface enables standard data to be exchanged with a higher level control system.
- ▶ PROFINET interface with PROFIsafe profile
  - The PROFINET interface with PROFIsafe profile enables data to be transferred safely between the PSS u2 and a master controller.
  - If a fault occurs, the module switches off the connected failsafe output modules.
  - The F-address is set via DIP switches or via the "PASconfig" tool.

All the project data is stored in the head module.

## 4.6.2 MAC addresses

The device MAC address is lasered on to the front of the head module. For "neighbourhood discovery" via the Link Layer Discovery Protocol (LLDP), PROFINET does not need the device MAC address but the MAC address of the physical Ethernet port, through which the device is connected to PROFINET. The head module has an integrated switch with 2 physical Ethernet ports. Both ports use the two MAC addresses that follow the device MAC address; i.e. a head module has 3 consecutive MAC addresses.

## 4.6.3 PROFIsafe groups

There are separate PROFIsafe groups for FS inputs and FS outputs. A separate F-address is configured for each PROFIsafe group.

If there is an error in the PROFIsafe group for the FS inputs (PROFIsafe group "IN"), all inputs in this group are deactivated. If there is an error in the PROFIsafe group for the FS outputs (PROFIsafe group "OUT"), all FS outputs in this group are deactivated.

The PROFIsafe groups have a fixed process data length. A PROFIsafe group has 8 bytes payload (max. 32 FS inputs / 64 FS outputs).

▶ PROFIsafe group for the FS inputs:

4 bytes for FS input data (e.g. max. 32 digital FS inputs) and 4 bytes for valid bits

▶ PROFIsafe group for the FS outputs:

8 bytes for FS output data (e.g. max. 64 digital FS outputs) and 8 bytes for valid bits in the process image of inputs

### System limits

The process image for the FS modules always occupies at least 1 Byte for the FS input or FS output data, even if all the bits are not used. This results in the following system limits:

- ▶ A maximum of 12 FS modules can be used
- ▶ A maximum of 4 FS input modules of type PSS u2 EF 8DI can be used
- ▶ A maximum of 8 FS output modules can be used

#### 4.6.4 Setting the F-address

The F-addresses can be set using the DIP switches or using PASconfig (see online help for PASconfig).

##### Setting via the DIP switch

The DIP switch has precedence over the setting in PASconfig. The F address set in PASconfig will only be used if no address has been set on the DIP switch.

The DIP switches are binary coded. Permitted F-addresses are in the range  $1_D \dots 1023_D$ . An F-address is set via a combination of the relevant binary coded switches:

DIP switch "IN ADDRESS" and "OUT ADDRESS"	Meaning		Example
	ON	OFF	
Switch designation	ON	OFF	F-address $52_D$
512	$512_D$	0	
256	$256_D$	0	
128	$128_D$	0	
64	$64_D$	0	
32	$32_D$	0	
16	$16_D$	0	
8	$8_D$	0	
4	$4_D$	0	
2	$2_D$	0	
1	$1_D$	0	



##### INFORMATION

Each F-address on PROFINET with PROFIsafe must be unique.

#### 4.6.5 Deactivation and reactivation

Both PROFIsafe groups can be brought to a safe condition selectively via the F-host. This is called deactivation.

- ▶ In the event of an error in the PROFIsafe group for the FS inputs
  - The VALID bit of the input modules becomes "0"
  - The PII is set to its safe value (=zero).
- ▶ In the event of an error in the PROFIsafe group for the FS outputs
  - The VALID bit of the output modules becomes "0"
  - The PIO is set to its safe value (=zero).

If the error is no longer present, the PROFIsafe group can be reintegrated. This is called re-activation. For reactivation, automatic or manual reintegration can be configured in the F-host. Automatic reintegration may only be configured if it is permitted for the respective process in terms of safety.

► Behaviour after reactivation

- The VALID bit becomes "1", provided there is no PROFIsafe module error.

#### 4.6.6 Projects

To configure the head module you will need the STEP 7 software or TIA Portal from Siemens and PASconfig. PASconfig can be called directly from STEP 7 or TIA Portal. The system data can be transferred to the head module with PASconfig via the PROFINET interfaces X3 or X4.



#### NOTICE

If a double-width module is used, a free slot must be left after the module in the Siemens STEP 7 software or TIA Portal. Reason: the module occupies two slots on the module rack but only one slot in STEP 7 or the TIA Portal.

#### 4.6.7 PROFIenergy

If the head module receives the energy saving command from the higher level controller, then it will activate the energy saving functions for all ST modules. The following energy saving functions are supported for ST modules:

- Switching off the LEDs
- Switching off the terminals on ST output modules

The head module does not support any energy saving functions for FS modules.

## 4.7 System reaction times

Calculation of the processing times for dual-channel signals.

### FS cycle time of the module

The FS cycle time  $t_{FS\_Cycle}$  of the module is 2 ms.

### Worst-Case Delay Time (WCDT) input

Calculation of the maximum time between a signal changing at the input and the signal being available at the fieldbus interface:

$$WCDT_{Input} = 7 * t_{FS\_Cycle} + t_{ProcIM\_wcd}$$

$t_{ProcIM\_wcd}$  : Maximum processing time of the input module, see under "Reaction time" of the input module.

### One Fault Delay Time (OFDT) input

Calculation of the maximum time between a signal changing at the input and the signal being available at the fieldbus interface when a fault occurs:

$$OFDT_{Input} = WCDT_{Input} = 7 * t_{FS\_Cycle} + t_{ProcIM\_ofd}$$

$t_{ProcIM\_ofd}$  : Maximum processing time of the input module when a fault occurs, see under "Reaction time" of the input module.

### Worst-Case Delay Time (WCDT) output

Calculation of the maximum time between the signal being received at the fieldbus interface and the output switching:

$$WCDT_{Output} = 6 * t_{FS\_Cycle} + t_{ProcOM\_wcd}$$

$t_{ProcOM\_wcd}$  : Maximum processing time of the output module, see under "Reaction time" of the output module.

### One Fault Delay Time (OFDT) output

Calculation of the maximum time between the signal being received at the fieldbus interface and the output switching when a fault is present:

$$OFDT_{Output} = WCDT_{Output} = 6 * t_{FS\_Cycle} + t_{ProcOM\_ofd}$$

$t_{ProcOM\_ofd}$  : Maximum processing time of the output module when a fault occurs, see under "Reaction time" of the output module.

### Device Acknowledge Time (DAT)

Calculation of the time between the signal being received at the fieldbus interface, the signal being confirmed and the confirmed signal being available at the fieldbus interface:

$$DAT = 2 * t_{FS\_Cycle}$$

## 4.8 Substitute values

If the valid bit has the value "0", then the process image is invalid and may not be used. If this is the case, the modules' process image has a substitute value which is used instead of the module's process value. Substitute values can be configured for digital ST output modules. For all other modules, the substitute value is the safe state ("0").

Situations that mean that substitute values are used and the valid bit has the value "0":

- ▶ Input error:
  - FS modules and ST modules with expanded diagnostics (e.g. PSS u2 ES 4DID) use the substitute value "0" for the affected input on the module.
- ▶ Output error
  - FS modules and ST modules with expanded diagnostics (e.g. PSS u2 ES 16DOD 0.5A) use the substitute value "0" for the affected output on the module.
- ▶ Module error (e.g. module overheats)
  - FS modules and ST modules with expanded diagnostics (e.g. PSS u2 ES 16DOD 0.5A) use the substitute values "0" for all the inputs/outputs on the module.
- ▶ Communication is stopped (even during firmware update)
  - FS modules and ST modules with expanded diagnostics (e.g. PSS u2 ES 16DOD 0.5A) use the substitute values "0" for all the inputs/outputs on the module.

## 5 Installation

### 5.1 General installation guidelines

Please refer to the PSS u2 Installation Manual.

The description below assumes that the mounting rail is already installed.



#### **NOTICE**

Damage due to electrostatic discharge!

Electrostatic discharge can damage components. Ensure against discharge before touching the product, e.g. by touching an earthed, conductive surface or by wearing an earthed armband.

## 5.2 Dimensions in mm

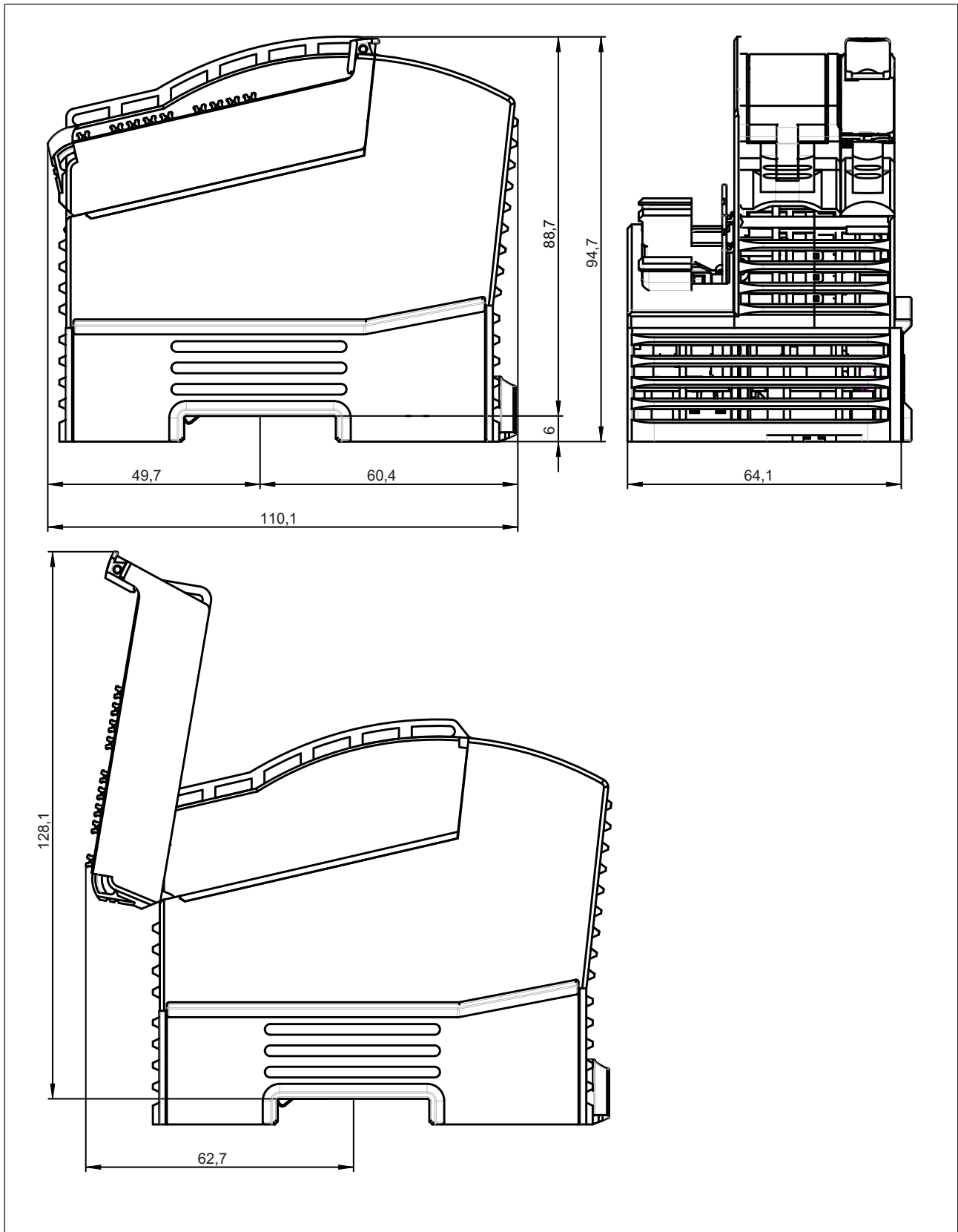

Fig.: Dimensions in mm

## 5.3 Installing the head module

Prerequisite:

The mounting rail must be installed.

1. Plug the head module on to the mounting rail.

Please note:

The mounting rail interlock must be in the open position, to the left.



2. Rotate the mounting rail interlock to the right to lock the head module on the mounting rail

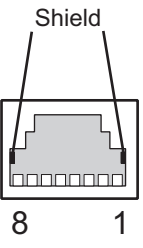
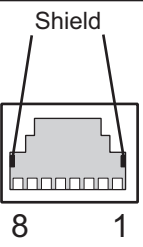

## 6 Interfaces

<b>X3</b>		
Female RJ45 connector in accordance with the guidelines of the PROFINET User Group (PNO)	8-core CAT-5 Ethernet patch cable	
<b>X4</b>		
Female RJ45 connector in accordance with the guidelines of the PROFINET User Group (PNO)	8-core CAT-5 Ethernet patch cable	



### INFORMATION

With the plug-in connection, please note that the data cable and connector have a limited mechanical load capacity. Appropriate design measures should be used to ensure that the plug-in connection is insensitive to increased mechanical stress (e.g. through shock, vibration). Such measures include, for example, fixed installation and strain relief (see graphic "Options for attaching the data cable to the head module").

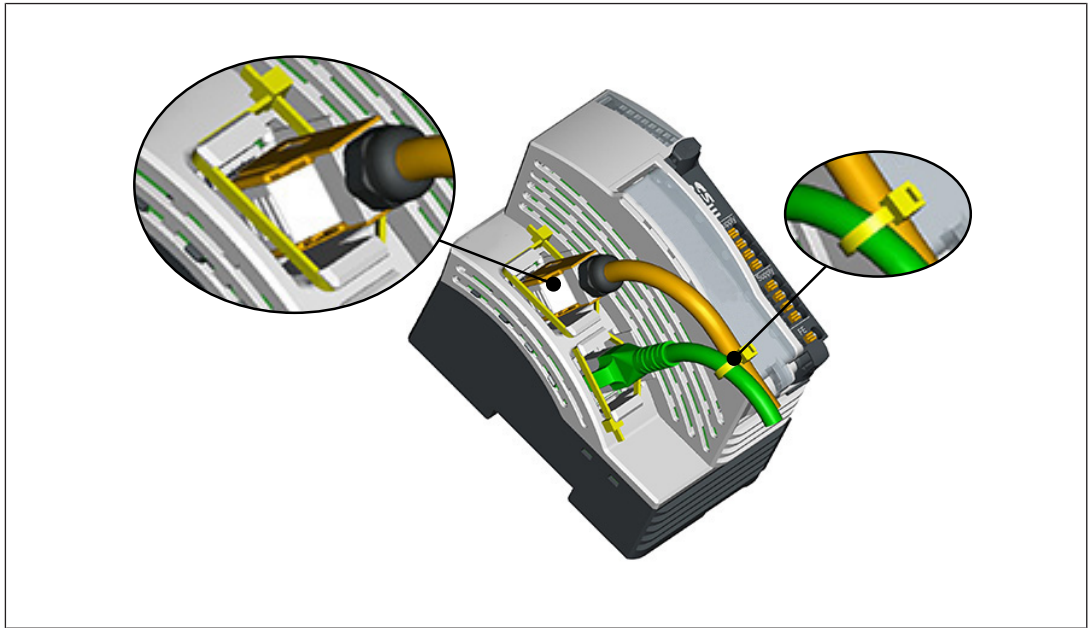

Fig.: Additional options for fastening the data cable on the head module and locking the connector using cable ties

- ▶ Remove the cable ties before pulling the plug.

## 7 Wiring

### 7.1 General wiring guidelines

- ▶ The requirements of the supply voltages can be found under "[Technical details \[📖 30\]](#)".
- ▶ Protective separation must be ensured for the external power supplies that generate the supply voltages. Failure to do so could result in electric shock.
- ▶ The supply voltages must be extra low voltages with safe electrical separation (PELV or SELV) in accordance with VDE 0100, Part 410. The external power supplies must comply with the current applicable standard EN 60950-1, EN 61140, EN 50178 or EN 61558-1.
- ▶ UL requirement: The supply voltages for module supply and periphery supply must be extra low voltages with safe electrical separation (PELV or SELV) in accordance with UL 61010-2-201 (IEC 61010-2-201:2013).
- ▶ The maximum current load for the periphery supply is 8 A.
- ▶ Earth the 0 V supply on the periphery supply or monitor each supply group for earth faults.
- ▶ The connection of the 0 V supply to the central earth bar or earth fault monitor must be in accordance with relevant national regulations (e.g. EN 60204-1, NFPA 79:17-7, NEC: Article 250).
- ▶ Details of the minimum range for cable cross sections on connection terminals can be found under "[Technical details \[📖 30\]](#)".
- ▶ Use copper wiring.
- ▶ The mounting rail must be earthed on both sides.

## 7.2 Connecting the module

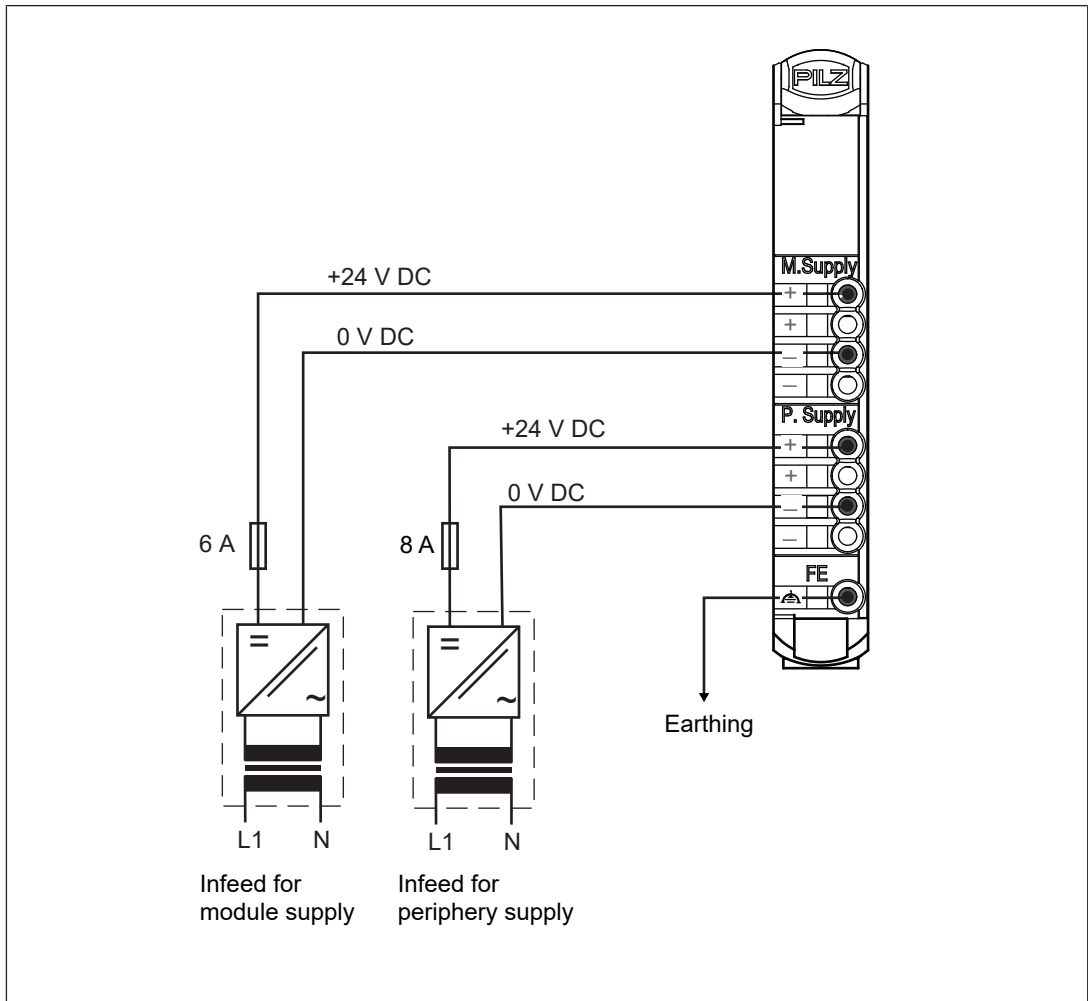

Fig.: Separate power supplies for module supply and periphery supply

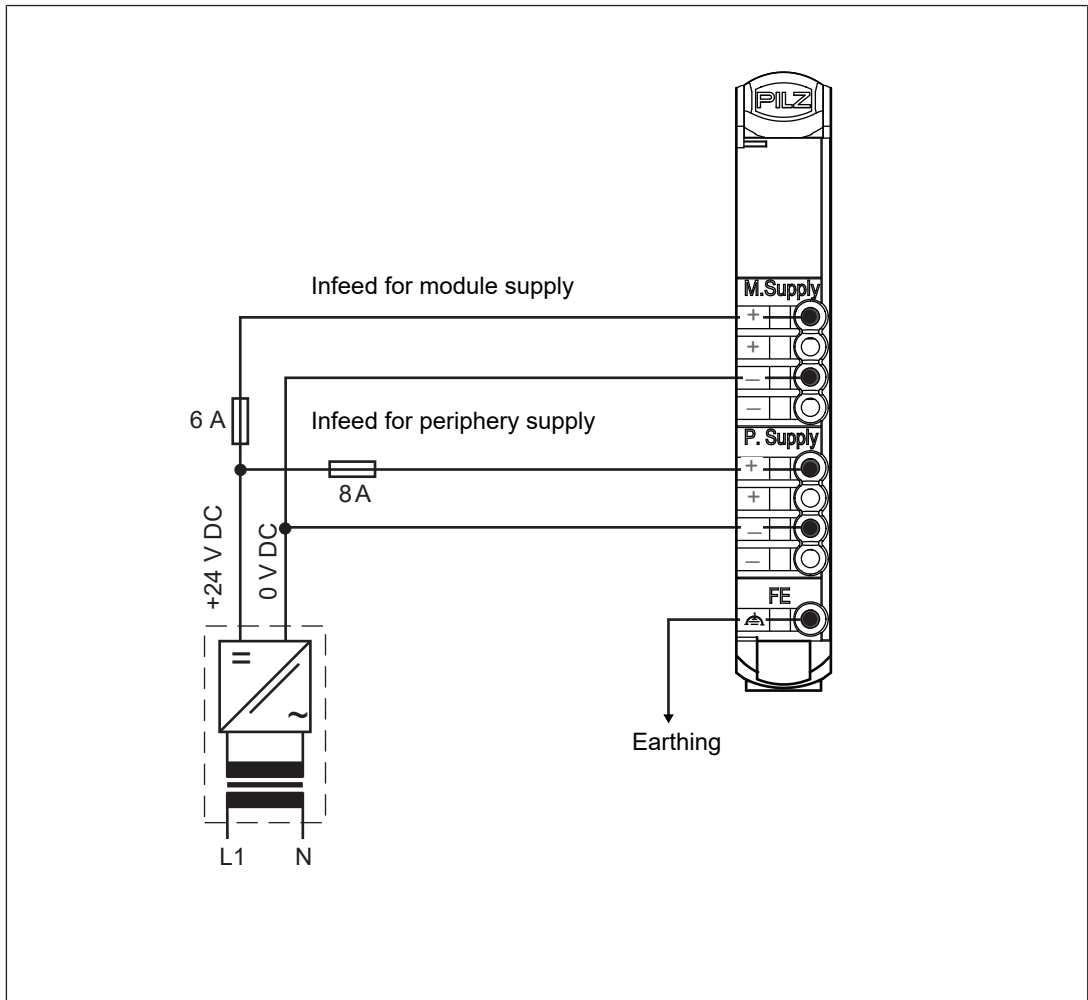

Fig.: Common power supply for module supply and periphery supply

Use the following fuses:

Module supply: max. 6 A characteristic B/C

Periphery supply: max. 10 A characteristic B/C

## 8 Operation

### 8.1 Display elements

The head module contains a number of status LEDs, which provide information on the status of various system sections.

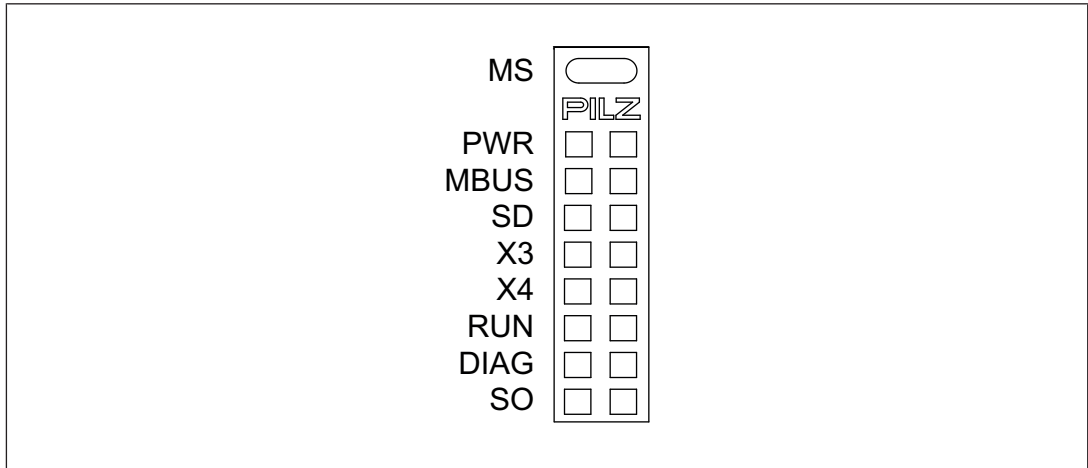





Fig.: LEDs on the head module PSS u2 P0 F/S PN

#### Legend

-  LED on
-  LED flashes
-  LED flashes briefly
-  LED off

#### 8.1.1 MS

Colour	State	Meaning
- - -	●	No supply voltage/not ready for operation
Green	●	Head module ready for operation
Green	☀	Head module in operation
Red	●	Module bus error
Red	☀	Head module error
Red	●	Updating firmware

### 8.1.2 PWR

Colour	State	Meaning
---	●	No supply voltage
Yellow	☀	Periphery supply is not available
Green	☀	Periphery supply and module supply ok

### 8.1.3 MBUS

The "MBUS" LED indicates the status of the ST module bus.

Colour	State	Meaning
---	●	ST module bus not in operation
Green	☀	ST module bus operating without error
Yellow	☀	The configured hardware registry does not match the actual hardware registry

### 8.1.4 SD

Colour	State	Meaning
---	●	No microSD card present
Yellow	☀	Confirmation for accepting the device project and configuration expected
Green	☀	microSD card present

### 8.1.5 X3, X4

These status LEDs are the display elements for the interfaces (X3 and X4). Each of the two interfaces is assigned an LED. Various operating and fault states are displayed via the LEDs.

#### X3, X4

Colour	State	Meaning
---	●	No network connection
Green	☀	Network connection present
Green	☀	Data traffic is error-free

### 8.1.6 RUN and DIAG

The LEDs "RUN" and "DIAG" indicate the status of the PROFINET interface.

DIAG		RUN		Meaning
green			green	Device identification activated by user
red			----	Diagnostic entry available/no PROFINET connection
red			green	Diagnostic entry available/ PROFINET connection available
----			green	Data exchange with PROFINET Controller
----			green	Head module does not yet have a device name

### 8.1.7 SO

The "SO" LED indicates the status of the PROFI-safe interface

Colour	State	Meaning
----		<ul style="list-style-type: none"> <li>▶ No PROFI-safe group configured</li> <li>▶ If only one PROFI-safe group was configured:                             <ul style="list-style-type: none"> <li>– F-parameter invalid, F-host in stop.</li> </ul> </li> <li>▶ If more than one PROFI-safe group was configured:                             <ul style="list-style-type: none"> <li>– At least one PROFI-safe group is signalling an error. Other PROFI-safe groups may be in operation.</li> </ul> </li> </ul>
green		One or more PROFI-safe groups in operation
green		One or more PROFI-safe groups require reintegration (e.g. after swapping an FS module)

## 9 Technical Details

<b>General</b>	
Certifications	<b>CE, EAC, KOSHA, TÜV, UKCA, cULus Listed</b>
Application range	<b>Standard/failsafe</b>
Module's device code	<b>C002h</b>
<b>Electrical data</b>	
Supply voltage	
for	<b>Module supply</b>
Voltage	<b>24 V</b>
Kind	<b>DC</b>
Voltage tolerance	<b>-30 %/+25 %</b>
Output of external power supply (DC)	<b>28,8 W</b>
Output of external power supply (DC) at no load	<b>5 W</b>
Max. output power	<b>22 W</b>
Residual ripple DC	<b>5 %</b>
Potential isolation	<b>Yes</b>
Buffer time	<b>20 ms</b>
Supply voltage	
for	<b>Periphery supply</b>
Voltage	<b>24 V</b>
Kind	<b>DC</b>
Voltage tolerance	<b>-30 %/+25 %</b>
Max. permitted current	<b>8 A</b>
Output of external power supply (DC)	<b>192 W</b>
Output of external power supply (DC) at no load	<b>0,5 W</b>
Residual ripple DC	<b>5 %</b>
Potential isolation	<b>Yes</b>
<b>PROFINET interface</b>	
Quantity	<b>2</b>
Input	<b>1.440 Byte</b>
Output	<b>1.440 Byte</b>
Transmission rates	<b>100 MBit/s</b>
Transmission rate selectable via	<b>Automatic</b>
Certification	<b>PNO</b>
Vendor ID	<b>092Fh</b>
Connection	<b>RJ45</b>
Device type	<b>IO-Device</b>
<b>Environmental data</b>	
Climatic suitability	<b>EN 60068-2-1, EN 60068-2-14, EN 60068-2-2, EN 60068-2-30, EN 60068-2-78</b>
Ambient temperature	
in accordance with the standard	<b>EN 60068-2-14</b>
Temperature range	<b>0 - 60 °C</b>

**Environmental data**

Storage temperature	
in accordance with the standard	<b>EN 60068-2-1/-2</b>
Temperature range	<b>-40 - 70 °C</b>
Climatic suitability	
in accordance with the standard	<b>EN 60068-2-78</b>
Humidity	<b>93 % r. h. at 40 °C</b>
Condensation during operation	<b>Not permitted</b>
Max. operating height above SL	<b>2000 m</b>
EMC	<b>EN 61131-2 (Zone B)</b>
Vibration	
in accordance with the standard	<b>EN 60068-2-6</b>
Frequency	<b>8,4 - 150 Hz</b>
Acceleration	<b>10 m/s<sup>2</sup></b>
Shock stress	
in accordance with the standard	<b>EN 60068-2-27</b>
Acceleration	<b>150 m/s<sup>2</sup></b>
Duration	<b>11 ms</b>
Airgap creepage	
in accordance with the standard	<b>EN 61131-2, UL/IEC 61010-2-201</b>
Overvoltage category	<b>II</b>
Pollution degree	<b>2</b>
Protection type	
Housing	<b>IP20</b>
Mounting area (e.g. control cabinet)	<b>IP54</b>

**Potential isolation**

Potential isolation between	<b>Supply voltage for module supply and periphery supply</b>
Type of potential isolation	<b>Functional insulation</b>
Rated surge voltage	<b>2500 V</b>
Potential isolation between	<b>Supply voltage for module supply and module supply</b>
Type of potential isolation	<b>Functional insulation</b>
Rated surge voltage	<b>2500 V</b>
Potential isolation between	<b>Periphery supply and module supply</b>
Type of potential isolation	<b>Functional insulation</b>
Rated surge voltage	<b>2500 V</b>
Potential isolation between	<b>Module Supply and PROFINET</b>
Type of potential isolation	<b>Functional insulation</b>
Rated surge voltage	<b>1500 V</b>

**Mechanical data**

Material	
Housing	<b>PC, PPE</b>
Bottom	<b>PPE</b>
Top	<b>PC</b>
Connection type	<b>Spring-loaded terminal</b>

Mechanical data	
Mounting type	plug-in
Conductor cross section with spring-loaded terminals: Flexible with/without crimp connector	
	0,15 - 1,5 mm <sup>2</sup> , 26 - 14 AWG
Dimensions	
Height	110,1 mm
Width	64,1 mm
Depth	94,7 mm
Weight	240 g

Where standards are undated, the 2015-04 latest editions shall apply.

## 9.1 Safety characteristic data



### NOTICE

You must comply with the safety characteristic data in order to achieve the required safety level for your plant/machine.

Operating mode	EN ISO 13849-1: 2015	EN ISO 13849-1: 2015	EN 62061 SIL CL	EN 62061 PFH <sub>D</sub> [1/h]	IEC 61511 SIL	IEC 61511 PFD	EN ISO 13849-1: 2015
	PL	Category					T <sub>M</sub> [year]
2-channel	PL e	Cat. 4	SIL CL 3	2,80E-09	SIL 3	8,91E-05	20

All the units used within a safety function must be considered when calculating the safety characteristic data.



### INFORMATION

A safety function's SIL/PL values are **not** identical to the SIL/PL values of the units that are used and may be different. We recommend that you use the PAScal software tool to calculate the safety function's SIL/PL values.

The safety-related characteristic data (PFH, PFD) are mean values. They have been calculated at an average ambient component temperature of 40 °C and apply for the ambient temperature range stated in the technical details.

## 10 Order reference

Product type	Features	Order no.
PSS u2 P0 F/S PN	Head module with PROFIsafe interface	328061

### 10.1 Accessories

#### Terminal block

Product type	Features	Order no.
PSS u2 T 9 SD (1 pc.)	Terminal block 9-pin for head module, supplied with: 1 piece	328831

#### microSD card

Product type	Features	Order no.
μSD memory card 1GB industrial	microSD memory card 1GB, industrial version, for PSS u2 head modules	328836

#### Shield connection element

Product type	Features	Order No.
PSS u2 A SH 4 (10 pcs.)	Shield connection element for backplane with 4 slots, scope of delivery: 10 pieces	328820

#### Labelling bracket

Product type	Features	Order No.
PSS u2 A LC E1 (10 pcs.)	Labelling bracket for electronic module 23.5 x 10.5 mm, scope of delivery: 10 pieces	328910
PSS u2 A LC E2 (10 pcs.)	Labelling bracket for electronic module 103 x 10.5 mm, scope of delivery: 10 pieces	328911
PSS u2 A LA E1 (10 pcs.)	Labelling strips for electronic module 23.5 x 10.5 mm (10 x DIN A4 sheet)	328913
PSS u2 A LA E2 (10 pcs.)	Labelling strips for electronic module 103 x 10.5 mm (10 x DIN A4 sheet)	328914

## 11 **EC declaration of conformity**

This product/these products meet the requirements of the directive 2006/42/EC on machinery of the European Parliament and of the Council. The complete EC Declaration of Conformity is available on the Internet at [www.pilz.com/downloads](http://www.pilz.com/downloads).

Representative: Pilz GmbH & Co. KG, Felix-Wankel-Str. 2, 73760 Ostfildern, Germany

## 12 UKCA-Declaration of Conformity

This product(s) complies with following UK legislation: Supply of Machinery (Safety) Regulation 2008.

The complete UKCA Declaration of Conformity is available on the Internet at [www.pilz.com/downloads](http://www.pilz.com/downloads).

Representative: Pilz Automation Technology, Pilz House, Little Colliers Field, Corby, Northamptonshire, NN18 8TJ United Kingdom, eMail: [mail@pilz.co.uk](mailto:mail@pilz.co.uk)

# Support

Technical support is available from Pilz round the clock.

## Americas

### Brazil

+55 11 97569-2804

### Canada

+1 888 315 7459

### Mexico

+52 55 5572 1300

### USA (toll-free)

+1 877-PILZUSA (745-9872)

## Asia

### China

+86 400-088-3566

### Japan

+81 45 471-2281

### South Korea

+82 31 778 3300

## Australia and Oceania

### Australia

+61 3 95600621

### New Zealand

+64 9 6345350

## Europe

### Austria

+43 1 7986263-444

### Belgium, Luxembourg

+32 9 3217570

### France

+33 3 88104003

### Germany

+49 711 3409-444

### Ireland

+353 21 4804983

### Italy, Malta

+39 0362 1826711

## Scandinavia

+45 74436332

## Spain

+34 938497433

## Switzerland

+41 62 88979-32

## The Netherlands

+31 347 320477

## Türkiye

+90 216 5775552

## United Kingdom

+44 1536 462203

## You can reach our international hotline on:

+49 711 3409-222

support@pilz.com

Pilz develops environmentally-friendly products using ecological materials and energy-saving technologies. Offices and production facilities are ecologically designed, environmentally-aware and energy-saving. So Pilz offers sustainability, plus the security of using energy-efficient products and environmentally-friendly solutions.



We are represented internationally. Please refer to our homepage [www.pilz.com](http://www.pilz.com) for further details or contact our headquarters.

Headquarters: Pilz GmbH & Co. KG, Felix-Wankel-Straße 2, 73760 Ostfildern, Germany  
Telephone: +49 711 3409-0, E-Mail: [info@pilz.com](mailto:info@pilz.com), Internet: [www.pilz.com](http://www.pilz.com)

**PILZ**  
THE SPIRIT OF SAFETY

CECE<sup>®</sup>, CHRE<sup>®</sup>, CMSE<sup>®</sup>, INDUSTRIAL P<sup>®</sup>, Leansafe<sup>®</sup>, Myzei<sup>®</sup>, PAS4000<sup>®</sup>, PASscal<sup>®</sup>, PASconfig<sup>®</sup>, Pilz<sup>®</sup>, PIT<sup>®</sup>, PIMCprimo<sup>®</sup>, PIMCprotego<sup>®</sup>, PIMCtiendo<sup>®</sup>, PMD<sup>®</sup>, PME<sup>®</sup>, PNOZ<sup>®</sup>, Primo<sup>®</sup>, PSEN<sup>®</sup>, PSS<sup>®</sup>, PSS<sup>®</sup>, PVIS<sup>®</sup>, SafetyBUS p<sup>®</sup>, SafetyNET p<sup>®</sup>, THE SPIRIT OF SAFETY<sup>®</sup> are registered and protected trademarks of Pilz GmbH & Co. KG in some countries. We would point out that product features may vary from the details stated in this document, depending on the status at the time of publication and the scope of the equipment. We accept no responsibility for the validity, accuracy and entirety of the text and graphics presented in this information. Please contact our Technical Support if you have any questions.

1003986-EN-10, 2024-06 Printed in Germany  
© Pilz GmbH & Co. KG, 2019