



► PSS u2 P0 F/S EIP

PILZ

THE SPIRIT OF SAFETY

Operating Manual-1004528-EN-08

- Remote I/O system PSS u2



This document is the original document.

Where unavoidable, for reasons of readability, the masculine form has been selected when formulating this document. We do assure you that all persons are regarded without discrimination and on an equal basis.

All rights to this documentation are reserved by Pilz GmbH & Co. KG. Copies may be made for the user's internal purposes. Suggestions and comments for improving this documentation will be gratefully received.

Pilz®, PIT®, PMI®, PNOZ®, Primo®, PSEN®, PSS®, PVIS®, SafetyBUS p®, SafetyEYE®, SafetyNET p®, the spirit of safety® are registered and protected trademarks of Pilz GmbH & Co. KG in some countries.



SD means Secure Digital

1	Introduction	5
1.1	Validity of documentation	5
1.2	Using the documentation	5
1.3	Third-party manufacturer licence information	5
1.4	Definition of symbols	5
2	Overview	7
2.1	Module features	7
2.2	Front view	8
2.3	Scope of supply	8
3	Safety	9
3.1	Intended use	9
3.2	System requirements	9
3.3	Safety regulations	10
3.3.1	Safety assessment	10
3.3.2	Use of qualified personnel	10
3.3.3	Warranty and liability	10
3.3.4	Disposal	10
4	Function description	11
4.1	Block diagram	11
4.2	Supply voltage	11
4.3	Integrated protection mechanisms	12
4.4	MicroSD card	12
4.5	Reset button	12
4.6	EtherNet/IP	13
4.6.1	Connection to EtherNet/IP	13
4.6.2	Setting the IP address	13
4.6.3	Projects	14
4.6.4	Diagnostic Object (0x64)	15
4.6.5	ST process image	16
4.7	CIP Safety	17
4.7.1	FS process image of inputs	17
4.7.2	FS process image of outputs	19
4.7.3	Restart interlock	20
4.7.4	CIP Safety requirements on the user	20
4.8	System reaction times	21
5	Installation	22
5.1	General installation guidelines	22
5.2	Dimensions in mm	23
5.3	Installing the head module	24
6	Interfaces	25
7	Wiring	27
7.1	General wiring guidelines	27

7.2	Connecting the module	28
8	Operation	30
8.1	Display elements	30
8.1.1	MS	30
8.1.2	PWR	30
8.1.3	MBUS	31
8.1.4	SD	31
8.1.5	X3, X4	31
8.1.6	NET	31
8.1.7	DIAG	32
8.1.8	MOD	32
9	Technical Details	33
9.1	Safety characteristic data	35
10	Order reference	36
10.1	Accessories	36
11	EC declaration of conformity	37
12	UKCA-Declaration of Conformity	38

1 Introduction

1.1 Validity of documentation

This operating manual explains the function and operation, describes the installation and provides guidelines on how to connect the product.

This documentation is valid for the product PSS u2 P0 F/S EIP hardware version 3.0 or higher. It is valid until new documentation is published.

1.2 Using the documentation

This document is intended for instruction. Only install and commission the product if you have read and understood this document. The document should be retained for future reference.

Please refer to the PSS u2 Installation Manual.

1.3 Third-party manufacturer licence information

The head modules include Open Source software with various licences.

Further information is available in the document "Third-party manufacturer licence information PSS u2 P0 F/S EIP" (document number 1006248) at www.pilz.com.

1.4 Definition of symbols

Information that is particularly important is identified as follows:



DANGER!

This warning must be heeded! It warns of a hazardous situation that poses an immediate threat of serious injury and death and indicates preventive measures that can be taken.



WARNING!

This warning must be heeded! It warns of a hazardous situation that could lead to serious injury and death and indicates preventive measures that can be taken.



CAUTION!

This refers to a hazard that can lead to a less serious or minor injury plus material damage, and also provides information on preventive measures that can be taken.



NOTICE

This describes a situation in which the product or devices could be damaged and also provides information on preventive measures that can be taken. It also highlights areas within the text that are of particular importance.



INFORMATION

This gives advice on applications and provides information on special features.

2 Overview

2.1 Module features

Application of the product PSS u2 P0 F/S EIP:

Head module to connect the system to EtherNet/IP™ with the CIP Safety™ protocol. The head module can be connected to a scanner as an adapter.

The product has the following features:

- ▶ **EtherNet/IP** interface with CIP Safety Protocol
- ▶ DIP switch for setting the IP address
- ▶ LEDs for:
 - System status
 - **EtherNet/IP** status
 - Module bus
 - Diagnostics
- ▶ Electronic modules that can be used for input/output:
 - Digital failsafe modules (PSS u2 EF...)
 - All standard modules (PSS u2 ES...)

2.2 Front view

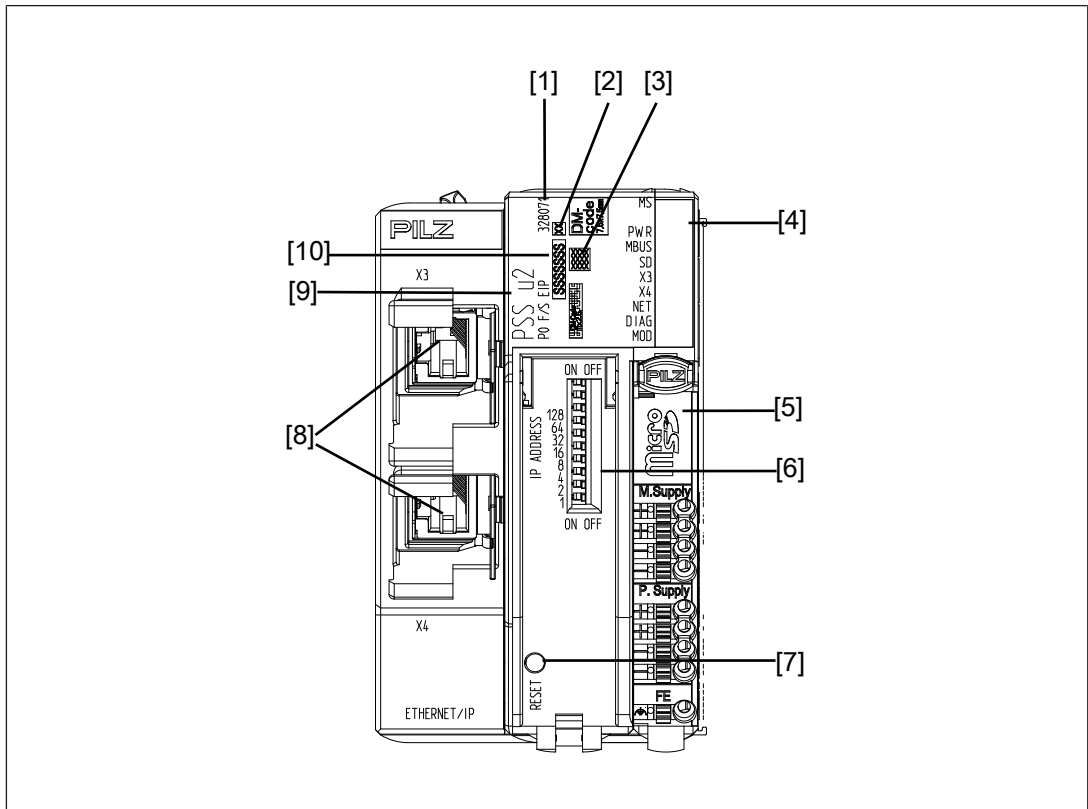

Fig.: Front view PSS u2 P0 F/S EIP

Legend

- 1 Order number
- 2 Hardware version
- 3 Devices MAC address
- 4 LEDs for status display
- 5 Terminal block for connecting the supply voltages (supplied with the device)
- 6 DIP switch for setting the IP address
- 7 Reset pushbutton
- 8 EtherNet/IP interface X3 and X4: RJ45 socket
- 9 Product name
- 10 Serial number

2.3 Scope of supply

- ▶ Head module PSS u2 P0 F/S EIP with:
 - 1 x Terminal block 9-pin

3 Safety

3.1 Intended use

The module PSS u2 P0 F/S EIP may only be used in the PSS u2 system.

The module is designed for use in

- ▶ safety-related applications with
 - CIP Safety via **EtherNet/IP**
- ▶ non-safety-related applications with
 - **EtherNet/IP**

The module meets the requirements of EN IEC 61508 up to SIL CL 3.

The module can be used in furnaces in accordance with EN 298.

Please note:

- ▶ To protect against transient power failures (EN 61000-4-11) the AC power supply used for the system must meet a secondary buffering for 30 ms.

Intended use includes making the electrical installation EMC-compliant. The module is designed for use in an industrial environment. Interference may occur if used in other areas.

The following is deemed improper use in particular

- ▶ Any component, technical or electrical modification to the module,
- ▶ Use of the module outside the areas described in this manual,
- ▶ Any use of the module that is not in accordance with the technical details.

Please also note the CIP Safety requirements (see [CIP Safety requirements on the user \[📖 20\]](#)). Further information is available at www.odva.org.

3.2 System requirements



INFORMATION

The module is supported by

- ▶ PASconfig from Version 4.0.0
 - We recommend that you always use the latest version (download from www.pilz.com).

3.3 Safety regulations

3.3.1 Safety assessment

Before using a device, a safety assessment in accordance with the Machinery Directive is required.

The product as an individual component fulfils the functional safety requirements in accordance with EN ISO 13849 and EN IEC 62061. However, this does not guarantee the functional safety of the overall plant/machine. To achieve the relevant safety level of the overall plant/machine's required safety functions, each safety function needs to be considered separately.

3.3.2 Use of qualified personnel

The products may only be assembled, installed, programmed, commissioned, operated, decommissioned and maintained by persons who are competent to do so.

A competent person is a qualified and knowledgeable person who, because of their training, experience and current professional activity, has the specialist knowledge required. In order to inspect, assess and handle products, devices, systems, plant and machinery, this person must be familiar with the state of the art and the applicable national, European and international laws, directives and standards.

It is the company's responsibility only to employ personnel who

- ▶ Are familiar with the basic regulations concerning health and safety / accident prevention,
- ▶ Have read and understood the information provided in the section entitled Safety
- ▶ Have a good knowledge of the generic and specialist standards applicable to the specific application.

3.3.3 Warranty and liability

All claims to warranty and liability will be rendered invalid if

- ▶ The product was used contrary to the purpose for which it is intended,
- ▶ Damage can be attributed to not having followed the guidelines in the manual,
- ▶ Operating personnel are not suitably qualified,
- ▶ Any type of modification has been made (e.g. exchanging components on the PCB boards, soldering work etc.).

3.3.4 Disposal

- ▶ In safety-related applications, please comply with the mission time T_M stated in the safety-related characteristic data.
- ▶ When decommissioning, please comply with local regulations regarding the disposal of electronic devices (e.g. Electrical and Electronic Equipment Act).

4 Function description

4.1 Block diagram

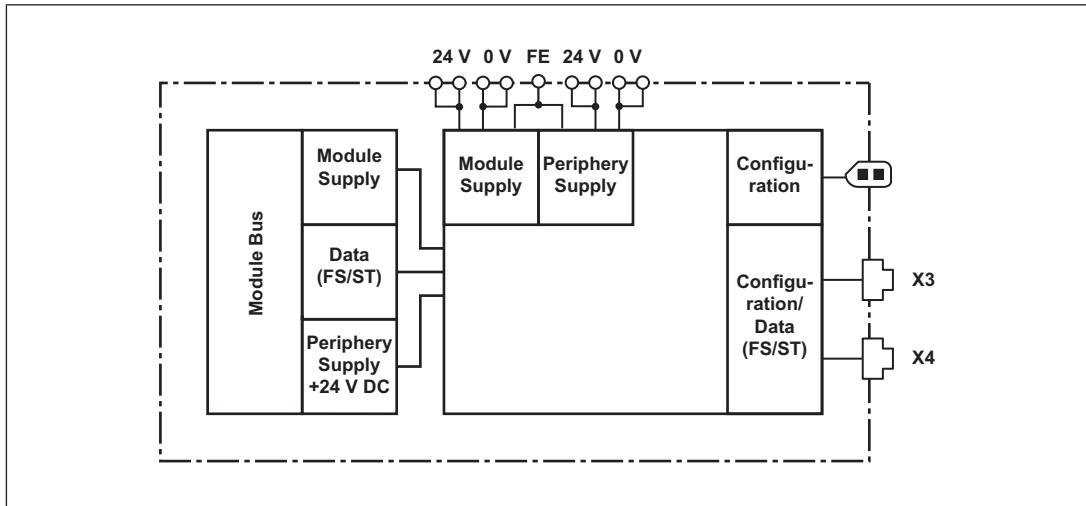

Fig.: Block diagram PSS u2 P0 F/S EIP

4.2 Supply voltage

- ▶ Module supply
 - supplies voltage to the head module
 - supplies voltage to downstream modules (right-hand side)
- ▶ Periphery supply
 - supplies voltage to the sensors, actuators and test pulses

When the supply voltage is fed in separately, the module supply and periphery supply are galvanically isolated. If galvanic isolation is not required, a common power supply may be used for the periphery supply and module supply.

Ensure you comply with the maximum output power of the module supply and periphery supply (see "[Technical details](#) [[33](#)]"). If the power consumption is higher, an additional supply voltage module is required to refresh the periphery supply. The module supply cannot be refreshed.

- ▶ Module supply
 - The total power consumption of all module racks and electronic modules must be \leq the maximum output power.
- ▶ Periphery supply
 - The total power consumption of the sensors, actuators and test pulses supplied via the input/output modules must be \leq the maximum output power.
 - If the periphery supply is missing, the "PWR" LED flashes and a message is entered in the diagnostic list.

4.3 Integrated protection mechanisms

The module has the following protection mechanisms:

- ▶ multi-channel diverse processor section
- ▶ cyclical self tests
- ▶ potentially isolated interface

Buffering:

Module supply failures are buffered for 20 ms.

4.4 MicroSD card

If you use the optional removable data medium, then data that is relevant for the device exchange will be stored on the data medium.



NOTICE

The microSD card includes safety data. Ensure that the microSD card is plugged in before commissioning. After commissioning, use PASconfig to check the FS check sum of the system on the microSD card. It has to match to the FS check sum of the configured system. To ensure that final data are stored on the data medium, do not remove the microSD card before completing the checking.

When a device is changed, the stored data can be copied over using the Reset button (see [Reset button](#) [ 12]).

4.5 Reset button

Carrying out a warm reset (restart)

Procedure:

- ▶ Press the Reset pushbutton for less than 5 seconds.

Performing a cold start/reboot command initiates the following procedure:

- ▶ Processing is aborted
 - All LEDs apart from the "PWR" LED are shut down
- ▶ System is initialised
 - Head module is ready for operation and the "MS" LED flashes green
- ▶ System switches to "Operational" state
 - Head module is in operation and the "MS" LED lights up green
- ▶ Operational entry in the error stack

Impact after a restart:

- ▶ Inputs retain their current input values
- ▶ Substitute values are used for the outputs until the connection to the controller has been re-established.

Copying the device project from the removable data medium to the PSS u2 system

Prerequisites

- ▶ A removable data medium must be plugged into the PSS u2 system.
- ▶ The removable data medium may not be empty or defective.
- ▶ The device project on the removable data medium must match the product type.

Procedure:

- ▶ Press the Reset pushbutton for more than 5 seconds. The SD LED flashes yellow.
- ▶ Release the Reset pushbutton, then press and release it again within 10 seconds.
- ▶ The device project will be copied from the removable data medium to the device.

If the required files are not on the removable data medium, the device exchange scenario is not performed and an entry is written in the error stack.

If no removable data medium is inserted, an original reset is performed.

▶ Default values:

- IP address: 192.168.1.1
- Subnet mask: 255.255.0.0
- Gateway address: 192.168.1.1

Effects of the original reset:

- ▶ ST and FS configuration data is deleted
- ▶ Error stack is not deleted
- ▶ The head module is restarted automatically.

4.6 EtherNet/IP

4.6.1 Connection to EtherNet/IP

Decentralised input/output

- ▶ The head module enables the PSS u2 to be used as a modular, decentralised input/output module.
- ▶ The head module receives signals from a higher level control system; it processes these signals and passes them on to the connected input/output modules.
- ▶ The head module receives signals from the connected input/output modules; it processes these signals and passes them on to a higher level control system.

All the project data is stored in the head module.

4.6.2 Setting the IP address

The IP address can be set using the DIP switch or using PASconfig (see online help for PASconfig).

Setting via the DIP switch

The DIP switch has precedence over the setting in PASconfig. The IP address set in PASconfig is only used if the DIP switch is set to 0 or 255.

The DIP switch only allows the last byte of the IP address to be set (192.168.1.xxx). xxx is the value that can be set with the DIP switch.

Subnet mask used: 255.255.255.0.

The DIP switch is binary coded. An IP address is set via a combination of the relevant binary coded switches:

"IP-ADDRESS" DIP switch	Meaning		Example
	ON	OFF	
Switch designation	ON	OFF	IP address 192.168.1.52
128	128 _D	0	
64	64 _D	0	
32	32 _D	0	
16	16 _D	0	
8	8 _D	0	
4	4 _D	0	
2	2 _D	0	
1	1	0	

4.6.3 Projects

The head module as an Ethernet/IP adapter can be used with different control systems that act as a scanner.

► Special features when using a control system from Rockwell Automation:

To configure the head module you will need the RSLogix 5000 software or Studio 5000 Logix Designer from Rockwell Automation and PASconfig. To simplify configuration, you can export the PSS u2 configuration from PASconfig to a *.l5x file and import it into RSLogix from Version 30.

► Special features when using a control system from Schneider Electric SE:

We recommend that you use the device description file (EDS) from Pilz. The EDS file is available on the Internet at www.pilz.de.

4.6.4 Diagnostic Object (0x64)

The Diagnostic Object makes diagnostic events available.

Class 0x64 Instance 0

Attribute ID	Name	Value	Description
1	Revision	1	Version of the Diagnostic Object
2	Max Instance	1	Max. number of Instances
3	Number of Instances	1	Number of Object Instances
6	Number of Class Attributes	7	Number of the last available Class Attribute
7	Number of Instance Attributes	2	Number of the last available Instance Attribute

Class 0x64 Instance 1

Attribute ID	Name	Bit	Value	Description
1	Diagnostic Byte ST (INT8U)	0	0	No error
			1	Fatal error on ST part
		1	0	No error
			1	ST error on head module
		2	0	No error
			1	Error on ST module
3...7	0	Reserved		
2	Diagnostic Byte FS (INT8U)	0	0	No error
			1	Fatal error on FS part
		1	0	No error
			1	Error on head module
		2	0	No error
			1	Error on FS module
3...7	0	Reserved		

The Diagnostic Object supports the following services:

Service Code	Class	Instance	Service Name	Description
0E _{hex}	Yes	Yes	Get_Attribute_Single	Read the value of one attribute
01 _{hex}	Yes	Yes	Get_Attribute_All	Read the value of all attributes

4.6.5 ST process image

Instance 101 in the Assembly Object (0x04) is used for the process image of the ST outputs.

Instance 104 in the Assembly Object (0x04) is used for the process image of the ST inputs.

Heartbeat instance in the Assembly Object (0x04): 198

Listen Only instance in the Assembly Object (0x04): 199

The sequence of the data in the process image depends on the slot number (beginning with slot 1). The length of the ST process data depends on the number of configured ST modules. If a module has a process image, the process image always occupies at least 1 byte, even if not all bits are used.

The valid bits of the ST outputs are transferred in the process image of the ST inputs.

Example of the process image of the ST inputs:

Byte	Bit 7	Bit 6	Bit 5	Bit 4	Bit 3	Bit 2	Bit 1	Bit 0	Slot	Module
0	n.u.	n.u.	n.u.	n.u.	I3	I2	I1	I0	1	PSS u2 ES 4DI
1	n.u.	n.u.	n.u.	n.u.	I3	I2	I1	I0	2	PSS u2 ES 4DID
2	n.u.	n.u.	n.u.	n.u.	n.u.	n.u.	V1	V0		
3	I7	I6	I5	I4	I3	I2	I1	I0	3	PSS u2 ES 8DI
4	I7	I6	I5	I4	I3	I2	I1	I0	4	PSS u2 ES 8DID
5	n.u.	n.u.	n.u.	n.u.	V3	V2	V1	V0		
6	n.u.	n.u.	n.u.	n.u.	V3	V2	V1	V0	5	PSS u2 ES4DOD
7	V7	V6	V5	V4	V3	V2	V1	V0	6	PSS u2 ES 8DOD
8	V7	V6	V5	V4	V3	V2	V1	V0	7	PSS u2 ES 16DOD
9	V15	V14	V13	V12	V11	V10	V9	V8		

Legend:

- ▶ I: Input
- ▶ n.u.: not used
- ▶ V: Valid bit

Example of the process image of the ST outputs:

Byte	Bit 7	Bit 6	Bit 5	Bit 4	Bit 3	Bit 2	Bit 1	Bit 0	Slot	Module
0	n.u.	n.u.	n.u.	n.u.	O3	O2	O1	O0	5	PSS u2 ES4DOD
1	O7	O6	O5	O4	O3	O2	O1	O0	6	PSS u2 ES 8DOD
2	O7	O6	O5	O4	O3	O2	O1	O0	7	PSS u2 ES 16DOD
3	O15	O14	O13	O12	O11	O10	O9	O8		

Legend:

- ▶ O: Output
- ▶ n.u.: not used

4.7 CIP Safety

System limits

The process image for the FS modules always occupies at least 1 Byte for the FS input or FS output data, even if all the bits are not used. This results in the following system limits:

- ▶ A maximum of 12 FS modules can be used
- ▶ A maximum of 4 FS input modules of type PSS u2 EF 8DI can be used
- ▶ A maximum of 8 FS output modules can be used



INFORMATION

When FS output modules are used in a PSS u2 system with a PSS u2 P0 F/S EIP head module, there must always be at least **one** FS input module.

4.7.1 FS process image of inputs

Instance 771 in the Assembly Object (0x04) is used for the process image of the FS inputs.

In the process image of the FS inputs, the Combined Input Status (CIS) is used to indicate whether all FS input modules supply valid values.

- ▶ CIS = 0: Not all FS input modules supply valid values
- ▶ CIS = 1: All FS input modules supply valid values

In the process image of the FS inputs, the Combined Output Status is used to indicate whether all FS output modules deliver valid values.

- ▶ COS = 0: Not all FS output modules deliver valid values
- ▶ COS = 1: All FS output modules deliver valid values

From byte 10 the process image of the FS inputs is used for the valid bits of the FS output modules.

Maximum length of the process image of the inputs: 18 bytes



INFORMATION

In the event of an input error, the valid bits for all inputs of all FS input modules are set to "0".

In the event of an output error, the valid bits for all outputs of all FS output modules are set to "0".

Process image of FS inputs (for digital FS modules with up to 8 inputs or up to 8 outputs):

Byte	Bits	Meaning
0	0	Combined Input Status (CIS)
	1...7	Not used
1	0	Combined Output Status (COS)
	1...7	Not used
2...3	0...15	FS-PII of the first FS input module (data and valid bits)
4...5	0...15	FS-PII of the second FS input module (data and valid bits)
6...7	0...15	FS-PII of the third FS input module (data and valid bits)
8...9	0...15	FS-PII of the fourth FS input module (data and valid bits)
10	0...15	FS-PII of the first FS output module (valid bits only)
...		
17	0...15	FS-PII of the eighth FS output module (valid bits only)

Example:

Byte	Bit 7	Bit 6	Bit 5	Bit 4	Bit 3	Bit 2	Bit 1	Bit 0	Slot	Module
0	n.u.	n.u.	n.u.	n.u.	n.u.	n.u.	n.u.	CIS		Head module
1	n.u.	n.u.	n.u.	n.u.	n.u.	n.u.	n.u.	COS		
2	I7	I6	I5	I4	I3	I2	I1	I0	1	PSS u2 EF 8DI
3	V7	V6	V5	V4	V3	V2	V1	V0		
4	I7	I6	I5	I4	I3	I2	I1	I0	2	PSS u2 EF 8DI
5	V7	V6	V5	V4	V3	V2	V1	V0		
6	I7	I6	I5	I4	I3	I2	I1	I0	3	PSS u2 EF 8DI
7	V7	V6	V5	V4	V3	V2	V1	V0		
8	I7	I6	I5	I4	I3	I2	I1	I0	4	PSS u2 EF 8DI
9	V7	V6	V5	V4	V3	V2	V1	V0		
10	V7	V6	V5	V4	V3	V2	V1	V0	5	PSS u2 EF 8DO
11	V7	V6	V5	V4	V3	V2	V1	V0	6	PSS u2 EF 8DO
12	V7	V6	V5	V4	V3	V2	V1	V0	7	PSS u2 EF 8DO
13	V7	V6	V5	V4	V3	V2	V1	V0	8	PSS u2 EF 8DO
14	V7	V6	V5	V4	V3	V2	V1	V0	9	PSS u2 EF 8DO
15	V7	V6	V5	V4	V3	V2	V1	V0	10	PSS u2 EF 8DO
16	n.u.	n.u.	n.u.	n.u.	V3	V2	V1	V0	11	PSS u2 EF 4DO
17	n.u.	n.u.	n.u.	n.u.	V3	V2	V1	V0	12	PSS u2 EF 4DO

Legend:

- ▶ CIS: Combined Input Status
- ▶ COS: Combined Output Status
- ▶ I: Input

- ▶ n.u.: not used
- ▶ O: Output
- ▶ V: Valid bit

4.7.2 FS process image of outputs

Instance 768 in the Assembly Object (0x04) is used for the process image of the FS outputs.

Maximum length of the process image of outputs: 8 bytes

Process image of FS outputs (for digital FS modules with up to 8 outputs):

Byte	Bits	Meaning
0	0...7	FS-PIO of the first FS output module (data only).
.		
.		
.		
7	0...7	FS-PIO of the eighth FS output module (data only).

Example:

Byte	Bit 7	Bit 6	Bit 5	Bit 4	Bit 3	Bit 2	Bit 1	Bit 0	Slot	Module
0	O7	O6	O5	O4	O3	O2	O1	O0	5	PSS u2 EF 8DO
1	O7	O6	O5	O4	O3	O2	O1	O0	6	PSS u2 EF 8DO
2	O7	O6	O5	O4	O3	O2	O1	O0	7	PSS u2 EF 8DO
3	O7	O6	O5	O4	O3	O2	O1	O0	8	PSS u2 EF 8DO
4	O7	O6	O5	O4	O3	O2	O1	O0	9	PSS u2 EF 8DO
5	O7	O6	O5	O4	O3	O2	O1	O0	10	PSS u2 EF 8DO
6	n.u.	n.u.	n.u.	n.u.	O3	O2	O1	O0	11	PSS u2 EF 4DO
7	n.u.	n.u.	n.u.	n.u.	O3	O2	O1	O0	12	PSS u2 EF 4DO

Legend:

- ▶ n.u.: not used
- ▶ O: Output

4.7.3 Restart interlock

The grouping of the FS inputs/FS outputs is determined by the user program in the control system.

The Combined Input Status (CIS) and Combined Output Status (COS) bits (see [FS process image of inputs](#)  17)) have the value “0” if one of the FS inputs or one of the FS outputs is faulty. Once an error at the FS inputs or FS outputs has been rectified, the modules are operational again immediately and the value of the status bits automatically changes to “1”. The CIP Safety Protocol does not contain any restart interlock. The restart interlock must be configured in the user program.

FS inputs

Example of the configuration of a restart interlock:

- ▶ In the user program of the programmable safety system, the value for CIS=0 must be saved in a control variable.
- ▶ The user program must link this control variable logically to every safe input with AND.
- ▶ The user program must reset this control variable to valid by reintegration. Only then will the values of the safe inputs be valid again.

FS outputs

Example of the configuration of a restart interlock:

- ▶ In the user program of the programmable safety system, the value for COS=0 must be saved in a control variable.
- ▶ The user program must link this control variable logically to every safe output with AND.
- ▶ The user program must reset this control variable to valid by reintegration. Only then will the values of the safe inputs be valid again.

4.7.4 CIP Safety requirements on the user

When using the device with the CIP Safety Protocol, you must verify whether the following requirements are met:

- ▶ If you are configuring an SIL3 device directly in the workstation, you must compare the transferred Safety Configuration ID and configuration data with the Safety Configuration ID and configuration data displayed in the workstation.
- ▶ You must run your own user tests to verify that the configuration data has been downloaded correctly.
- ▶ LEDs are not safe and should only be used for non-safety-related purposes. Use LEDs only for general diagnostics during commissioning or troubleshooting. Do not use LEDs for display during operation.
- ▶ For every safety network or safety subnet, you must issue a Safety Network Number (SNN) that is unique across the entire system.
- ▶ If you configure the Safety Configuration Identifier (SCID), also known as the Configuration Signature, of a safety connection with “0”, you must ensure that the scanner and the adapter are configured correctly.
- ▶ In the scanner you must only use the “automatic” setting for the Safety Network Number (SNN) if the system is not safety-related.

- ▶ Before installing a safety device in a safety network, you must delete a configuration already existing on this device.
- ▶ Before changing a safety device, you must ensure that the replacement device is configured correctly. After making the change, verify that the exchanged device is working properly.

4.8 System reaction times

Calculation of the processing times for dual-channel signals.

FS cycle time of the module

The FS cycle time t_{FS_Cycle} of the module is 2 ms.

Worst-case reaction time of an input

Calculation of the maximum time between a signal changing at the input and the signal being available at the fieldbus interface:

Worst-case reaction time of an input = $7 * t_{FS_Cycle} + t_{ProclM_ofd}$

t_{ProclM_ofd} : Maximum processing time of the input module when a fault occurs, see under "Reaction time" of the input module.

Worst-case reaction time of an output

Calculation of the maximum time between the signal being received at the fieldbus interface and the output switching:

Worst-case reaction time of an output = $6 * t_{FS_Cycle} + t_{ProcOM_ofd}$

t_{ProcOM_ofd} : Maximum processing time of the output module when a fault occurs, see under "Reaction time" of the output module.

5 Installation

5.1 General installation guidelines

Please refer to the PSS u2 Installation Manual.

The description below assumes that the mounting rail is already installed.



NOTICE

Damage due to electrostatic discharge!

Electrostatic discharge can damage components. Ensure against discharge before touching the product, e.g. by touching an earthed, conductive surface or by wearing an earthed armband.

5.2 Dimensions in mm

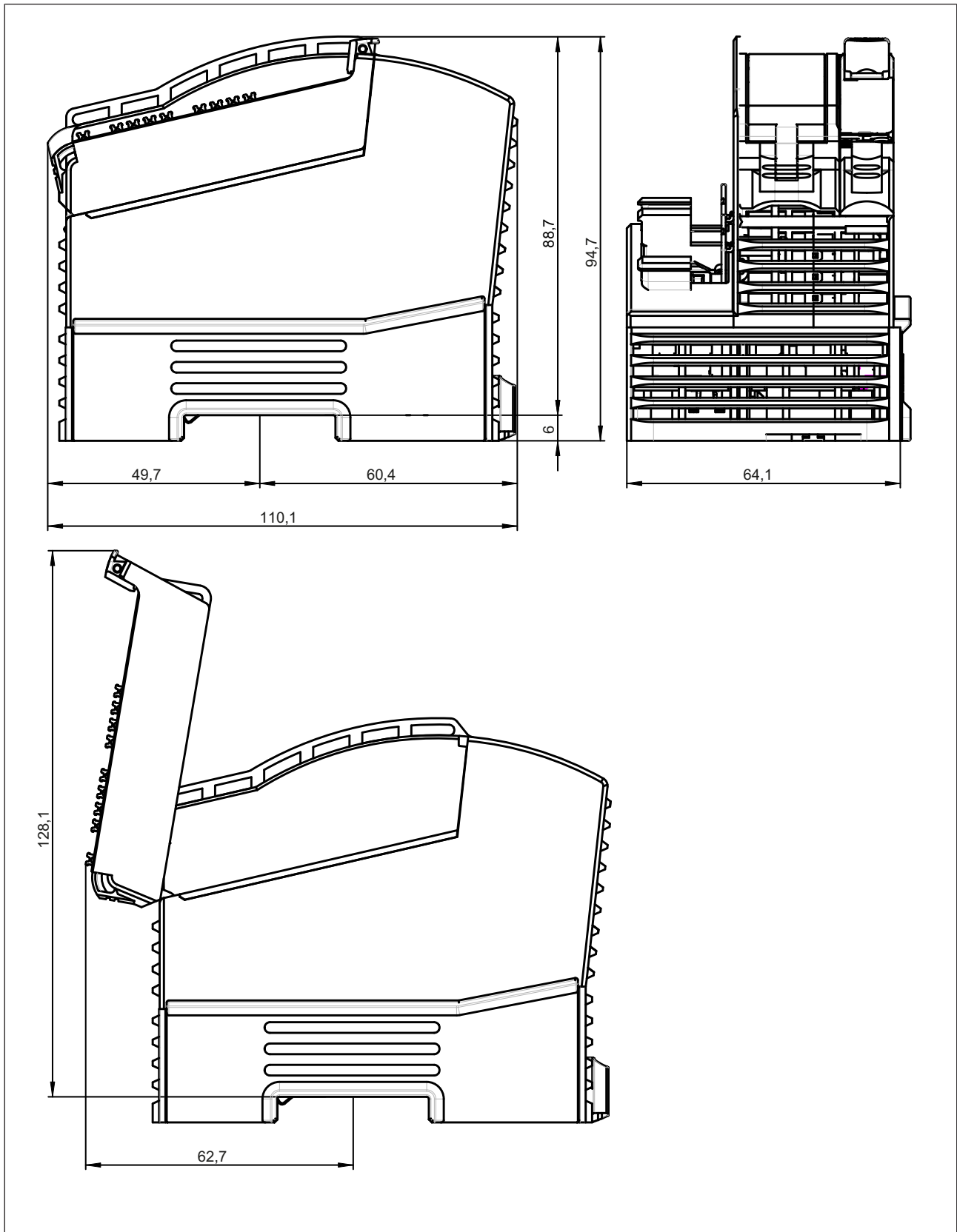

Fig.: Dimensions in mm

5.3 Installing the head module

Prerequisite:

The mounting rail must be installed.

1. Plug the head module on to the mounting rail.
Please note:
The mounting rail interlock must be in the open position, to the left.

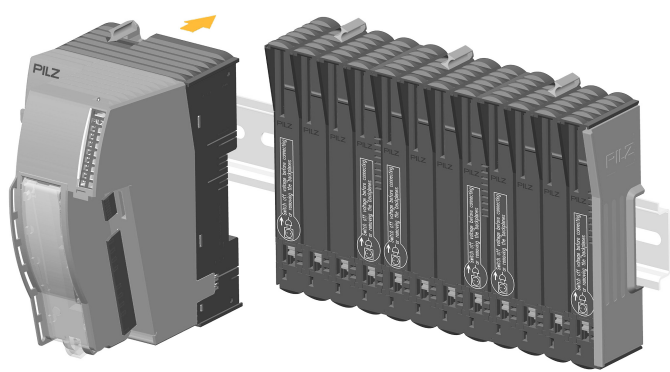

2. Rotate the mounting rail interlock to the right to lock the head module on the mounting rail

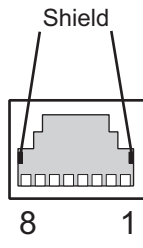
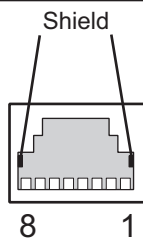

6 Interfaces

X3		
RJ45 female connector	8-core CAT-5 Ethernet patch cable	
X4		
RJ45 female connector	8-core CAT-5 Ethernet patch cable	



INFORMATION

With the plug-in connection, please note that the data cable and connector have a limited mechanical load capacity. Appropriate design measures should be used to ensure that the plug-in connection is insensitive to increased mechanical stress (e.g. through shock, vibration). Such measures include, for example, fixed installation and strain relief (see graphic "Options for attaching the data cable to the head module").

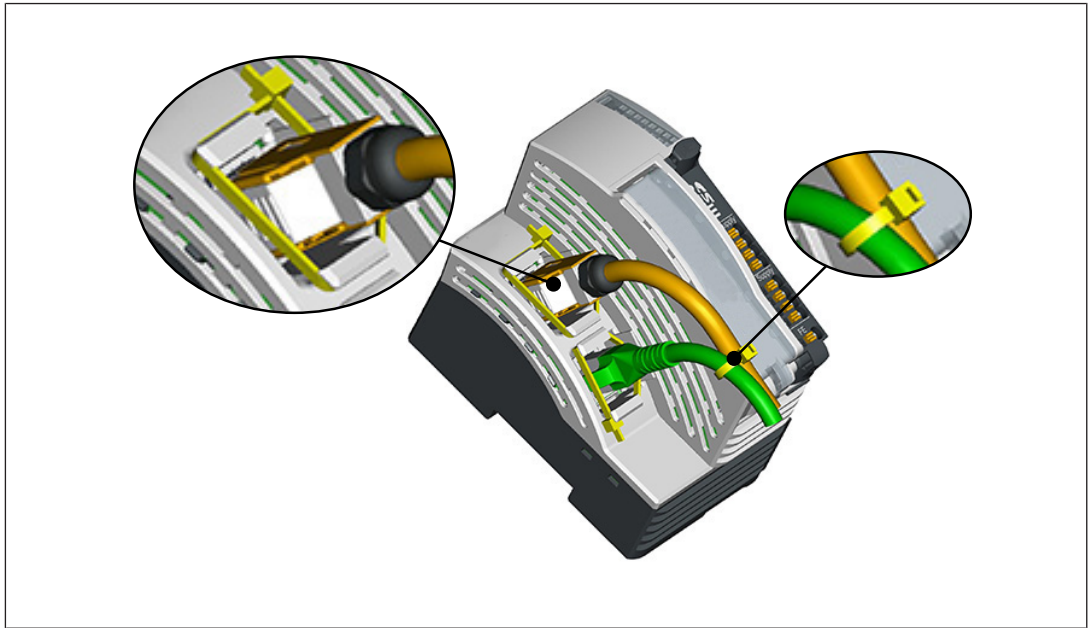

Fig.: Additional options for fastening the data cable on the head module and locking the connector using cable ties

- ▶ Remove the cable ties before pulling the plug.

7 Wiring

7.1 General wiring guidelines

- ▶ The requirements of the supply voltages can be found under "[Technical details !\[\]\(181300cc4f79373257c198522fe52e3c_img.jpg\) 33](#)".
- ▶ Protective separation must be ensured for the external power supplies that generate the supply voltages. Failure to do so could result in electric shock.
- ▶ The supply voltages must be extra low voltages with safe electrical separation (PELV or SELV) in accordance with VDE 0100, Part 410. The external power supplies must comply with the current applicable standard EN 60950-1, EN 61140, EN 50178 or EN 61558-1.
- ▶ UL requirement: The supply voltages for module supply and periphery supply must be extra low voltages with safe electrical separation (PELV or SELV) in accordance with UL 61010-2-201 (IEC 61010-2-201:2013).
- ▶ The maximum current load for the periphery supply is 8 A.
- ▶ Earth the 0 V supply on the periphery supply or monitor each supply group for earth faults.
- ▶ The connection of the 0 V supply to the central earth bar or earth fault monitor must be in accordance with relevant national regulations (e.g. EN 60204-1, NFPA 79:17-7, NEC: Article 250).
- ▶ Details of the minimum range for cable cross sections on connection terminals can be found under "[Technical details !\[\]\(a0d3e5b2630c201d3f5d5ef8b98bc944_img.jpg\) 33](#)".
- ▶ Use copper wiring.
- ▶ The mounting rail must be earthed on both sides.

7.2 Connecting the module

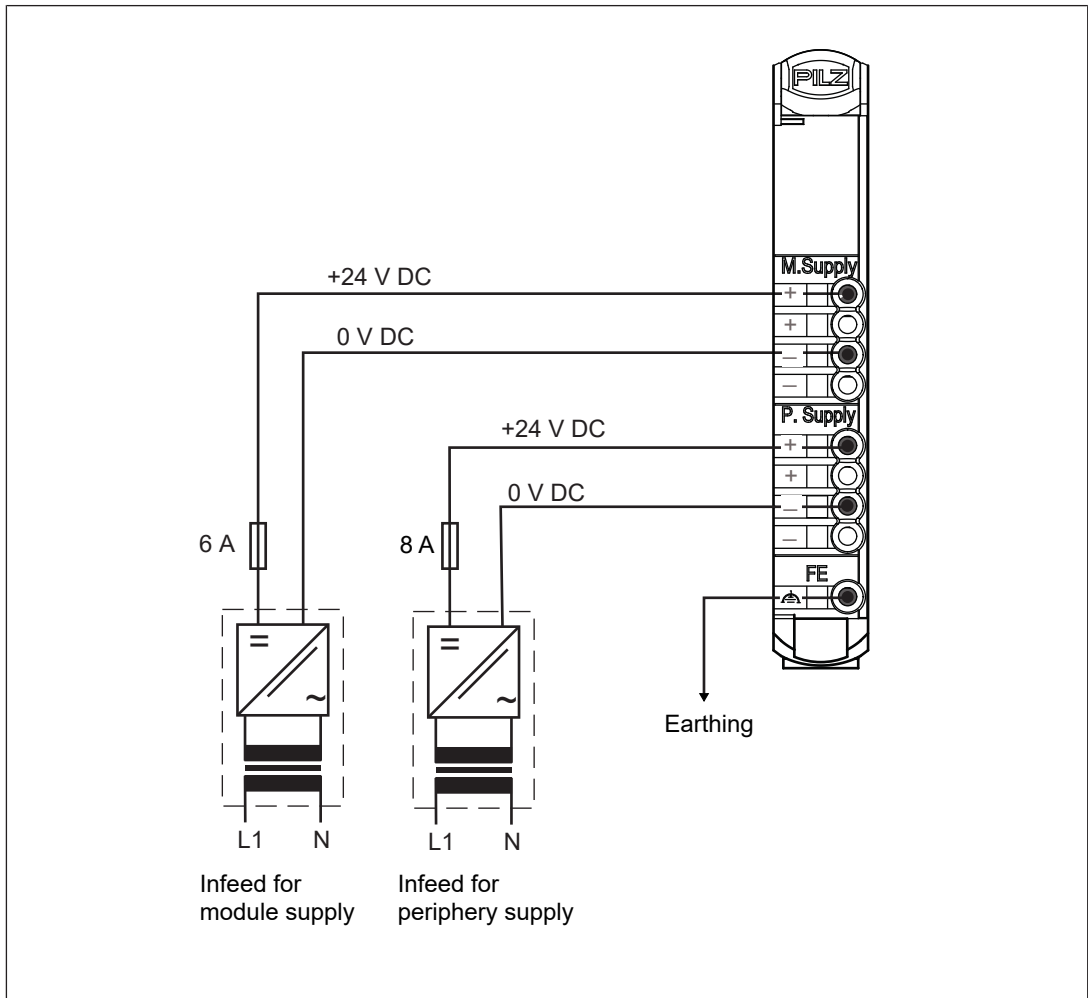

Fig.: Separate power supplies for module supply and periphery supply

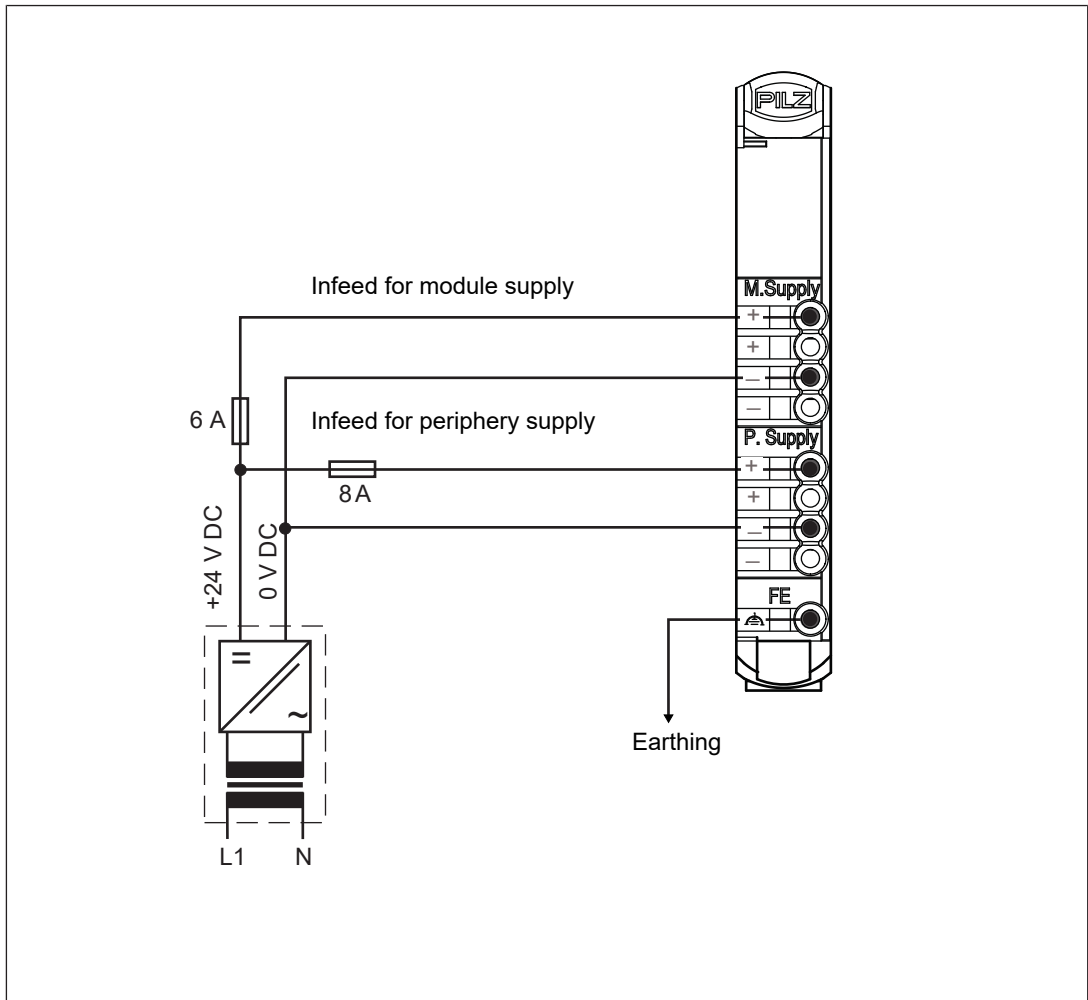

Fig.: Common power supply for module supply and periphery supply

Use the following fuses:

Module supply: max. 6 A characteristic B/C

Periphery supply: max. 10 A characteristic B/C

8 Operation

8.1 Display elements

The head module contains a number of status LEDs, which provide information on the status of various system sections.

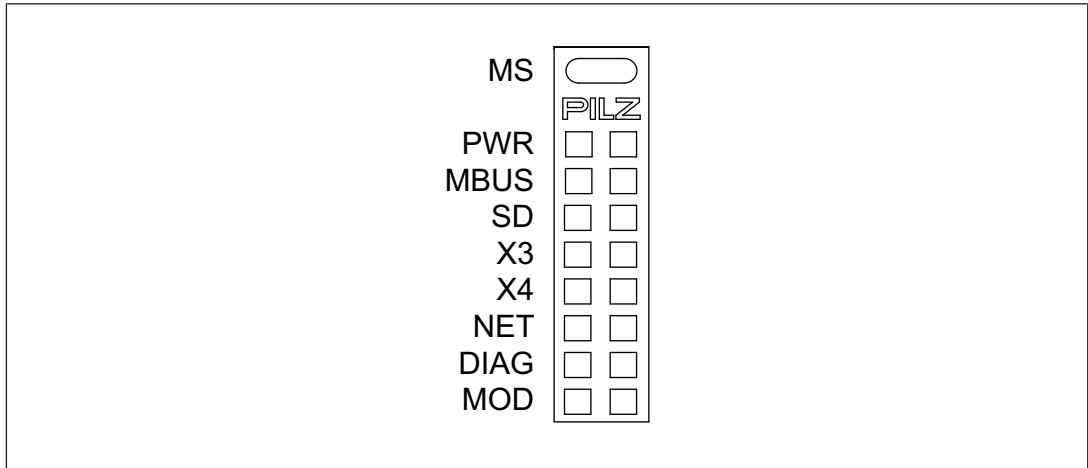

Fig.: LEDs on the head module PSS u2 P0 F/S EIP

8.1.1 MS

Colour	State	Meaning
- - -	●	No supply voltage/not ready for operation
Green	●	Head module ready for operation
Green	☀	Head module in operation
Red	●⚡	Module bus error
Red	☀	Head module error
Red	●	Updating firmware

8.1.2 PWR

Colour	State	Meaning
- - -	●	No supply voltage
Yellow	☀	Periphery supply is not available
Green	☀	Periphery supply and module supply ok

8.1.3 MBUS

The "MBUS" LED indicates the status of the ST module bus.

Colour	State	Meaning
---	●	ST module bus not in operation
Green	☀	ST module bus operating without error
Yellow	☀	The configured hardware registry does not match the actual hardware registry

8.1.4 SD

Colour	State	Meaning
---	●	No microSD card present
Yellow	☀	Confirmation for accepting the device project and configuration expected
Green	☀	microSD card present

8.1.5 X3, X4

These status LEDs are the display elements for the interfaces (X3 and X4). Each of the two interfaces is assigned an LED. Various operating and fault states are displayed via the LEDs.

X3, X4



Colour	State	Meaning
---	●	No network connection
Green	☀	Network connection present
Green	☀	Data traffic is error-free

8.1.6 NET







Colour	State	Meaning
---	●	Device switched off or not online
Green	☀	No active network connections
Green	☀	Active network connections available
Red	☀	One or more I/O connections timed out
Red	☀	Communication has failed
Red/green	☀	Device has discovered a network access error and the connection has failed or the device is in self-test

8.1.7 DIAG





The "DIAG" LEDs indicate whether a diagnostic message is present.

Colour	State	Meaning
Red		Diagnostic entry present
---		No diagnostic entry present

8.1.8 MOD

Colour	State	Meaning
---		No supply voltage present
Green		Device in operation
Green		Device is in Idle or Standby mode
Red		Repairable error
Red		Internal error
Red/green		Device is in self-test or the configuration is not complete

Legend

-  LED on
-  LED flashes
-  LED flashes briefly
-  LED off

9 Technical Details

General	
Certifications	CE, EAC, TÜV, UKCA, cULus Listed
Application range	Standard/failsafe
Module's device code	C006h
System sections	
EtherNet/IP (TM) adapter	Yes
Electrical data	
Supply voltage	
for	Module supply
Voltage	24 V
Kind	DC
Voltage tolerance	-30 %/+25 %
Output of external power supply (DC)	28,8 W
Output of external power supply (DC) at no load	5 W
Max. output power	22 W
Residual ripple DC	5 %
Potential isolation	Yes
Buffer time	20 ms
Supply voltage	
for	Periphery supply
Voltage	24 V
Kind	DC
Voltage tolerance	-30 %/+25 %
Max. permitted current	8 A
Output of external power supply (DC)	192 W
Output of external power supply (DC) at no load	0,5 W
Residual ripple DC	5 %
Potential isolation	Yes
Removable data medium	
Type	microSD
EtherNet/IP (TM) adapter	
Vendor ID	181
Product ID	256
Device type	Adapter
Cycle time (RPI)	1 ... 3200 ms
Maximum data length	508 Byte
Maximum number of I/O connections	1
Certification	ODVA
Transmission rate	100 Mbit/s
CIP Safety	
Cycle time (RPI)	6 ... 3200 ms
Maximum data length	18 Byte

CIP Safety	
Maximum number of I/O connections	2
Environmental data	
Climatic suitability	EN 60068-2-1, EN 60068-2-14, EN 60068-2-2, EN 60068-2-30, EN 60068-2-78
Ambient temperature	
in accordance with the standard	EN 60068-2-14
Temperature range	0 - 60 °C
Storage temperature	
in accordance with the standard	EN 60068-2-1/-2
Temperature range	-40 - 70 °C
Climatic suitability	
in accordance with the standard	EN 60068-2-78
Humidity	93 % r. h. at 40 °C
Condensation during operation	Not permitted
Max. operating height above SL	2000 m
EMC	EN 61131-2 (Zone B)
Vibration	
in accordance with the standard	EN 60068-2-6
Frequency	8,4 - 150 Hz
Acceleration	10 m/s²
Shock stress	
in accordance with the standard	EN 60068-2-27
Acceleration	150 m/s²
Duration	11 ms
Airgap creepage	
in accordance with the standard	EN 61131-2, UL/IEC 61010-2-201
Overvoltage category	II
Pollution degree	2
Protection type	
Housing	IP20
Mounting area (e.g. control cabinet)	IP54
Potential isolation	
Potential isolation between	Supply voltage for module supply and periphery supply
Type of potential isolation	Functional insulation
Rated surge voltage	2500 V
Potential isolation between	Supply voltage for module supply and module supply
Type of potential isolation	Functional insulation
Rated surge voltage	2500 V
Potential isolation between	Periphery supply and module supply
Type of potential isolation	Functional insulation
Rated surge voltage	2500 V
Potential isolation between	Module Supply and EtherNet/IP (TM)
Type of potential isolation	Functional insulation

Potential isolation	
Rated surge voltage	1500 V
Mechanical data	
Material	
Housing	PC, PPE
Bottom	PPE
Top	PC
Connection type	Spring-loaded terminal
Mounting type	plug-in
Conductor cross section with spring-loaded terminals: Flexible with/without crimp connector	
	0,15 - 1,5 mm ² , 26 - 14 AWG
Dimensions	
Height	110,1 mm
Width	64,1 mm
Depth	94,7 mm
Weight	240 g

Where standards are undated, the 2017-05 latest editions shall apply.

9.1 Safety characteristic data



NOTICE

You must comply with the safety characteristic data in order to achieve the required safety level for your plant/machine.

Operating mode	EN ISO 13849-1: 2015	EN ISO 13849-1: 2015	EN IEC 62061 SIL CL/max.	EN IEC 62061 61508	EN/IEC 61511 61508	EN/IEC 61511 61508	EN ISO 13849-1: 2015
	PL	Category	SIL	PFH [1/h]	SIL	PFD	T _M [year]
2-channel	PL e	Cat. 4	SIL CL 3	2,80E-09	SIL 3	8,91E-05	20

All the units used within a safety function must be considered when calculating the safety characteristic data.



INFORMATION

A safety function's SIL/PL values are **not** identical to the SIL/PL values of the units that are used and may differ from these.

The safety-related characteristic data (PFH, PFD) are mean values. They have been calculated at an average ambient component temperature of 40 °C.

10 Order reference

Product type	Features	Order no.
PSS u2 P0 F/S EIP	Head module with EtherNet/IP connection	328071

10.1 Accessories

Terminal block

Product type	Features	Order no.
PSS u2 T 9 SD (1 pc.)	Terminal block 9-pin for head module, supplied with: 1 piece	328831

microSD card

Product type	Features	Order no.
μSD memory card 1GB industrial	microSD memory card 1GB, industrial version, for PSS u2 head modules	328836

Shield connection element

Product type	Features	Order No.
PSS u2 A SH 4 (10 pcs.)	Shield connection element for backplane with 4 slots, scope of delivery: 10 pieces	328820

Labelling bracket

Product type	Features	Order No.
PSS u2 A LC E1 (10 pcs.)	Labelling bracket for electronic module 23.5 x 10.5 mm, scope of delivery: 10 pieces	328910
PSS u2 A LC E2 (10 pcs.)	Labelling bracket for electronic module 103 x 10.5 mm, scope of delivery: 10 pieces	328911
PSS u2 A LA E1 (10 pcs.)	Labelling strips for electronic module 23.5 x 10.5 mm (10 x DIN A4 sheet)	328913
PSS u2 A LA E2 (10 pcs.)	Labelling strips for electronic module 103 x 10.5 mm (10 x DIN A4 sheet)	328914

11 **EC declaration of conformity**

This product/these products meet the requirements of the directive 2006/42/EC on machinery of the European Parliament and of the Council. The complete EC Declaration of Conformity is available on the Internet at www.pilz.com/downloads.

Representative: Pilz GmbH & Co. KG, Felix-Wankel-Str. 2, 73760 Ostfildern, Germany

12 UKCA-Declaration of Conformity

This product(s) complies with following UK legislation: Supply of Machinery (Safety) Regulation 2008.

The complete UKCA Declaration of Conformity is available on the Internet at www.pilz.com/downloads.

Representative: Pilz Automation Technology, Pilz House, Little Colliers Field, Corby, Northamptonshire, NN18 8TJ United Kingdom, eMail: mail@pilz.co.uk

► Support

Technical support is available from Pilz round the clock.

Americas

Brazil

+55 11 97569-2804

Canada

+1 888 315 7459

Mexico

+52 55 5572 1300

USA (toll-free)

+1 877-PILZUSA (745-9872)

Asia

China

+86 400-088-3566

Japan

+81 45 471-2281

South Korea

+82 31 778 3300

Australia and Oceania

Australia

+61 3 95600621

New Zealand

+64 9 6345350

Europe

Austria

+43 1 7986263-444

Belgium, Luxembourg

+32 9 3217570

France

+33 3 88104003

Germany

+49 711 3409-444

Ireland

+353 21 4804983

Italy, Malta

+39 0362 1826711

Scandinavia

+45 74436332

Spain

+34 938497433

Switzerland

+41 62 88979-32

The Netherlands

+31 347 320477

Türkiye

+90 216 5775552

United Kingdom

+44 1536 462203

You can reach our international hotline on:

+49 711 3409-222

support@pilz.com

Pilz develops environmentally-friendly products using ecological materials and energy-saving technologies. Offices and production facilities are ecologically designed, environmentally-aware and energy-saving. So Pilz offers sustainability, plus the security of using energy-efficient products and environmentally-friendly solutions.



We are represented internationally. Please refer to our homepage www.pilz.com for further details or contact our headquarters.

Headquarters: Pilz GmbH & Co. KG, Felix-Wankel-Straße 2, 73760 Ostfildern, Germany
Telephone: +49 711 3409-0, E-Mail: info@pilz.com, Internet: www.pilz.com

PILZ
THE SPIRIT OF SAFETY

CECE[®], CHRE[®], CMSE[®], INDUSTRIAL P[®], Leansafe[®], Myzei[®], PAS4000[®], PASscal[®], PASconfig[®], Pilz[®], PIT[®], PMSprimo[®], PMSprotego[®], PMCiendo[®], PMD[®], PME[®], PNOZ[®], Primo[®], PSEN[®], PSS[®], PVIS[®], SafetyBUS p[®], SafetyNET p[®], THE SPIRIT OF SAFETY[®] are registered and protected trademarks of Pilz GmbH & Co. KG in some countries. We would point out that product features may vary from the details stated in this document, depending on the status at the time of publication and the scope of the equipment. We accept no responsibility for the validity, accuracy and entirety of the text and graphics presented in this information. Please contact our Technical Support if you have any questions.

1004528-EN-08, 2024-06 Printed in Germany
© Pilz GmbH & Co. KG, 2019