



PSS u2 ES 8DI

PILZ
THE SPIRIT OF SAFETY

- ▶ Control system PSS u2
- ▶ Remote I/O system PSS u2

This document is the original document.

Where unavoidable, for reasons of readability, the masculine form has been selected when formulating this document. We do assure you that all persons are regarded without discrimination and on an equal basis.

All rights to this documentation are reserved by Pilz GmbH & Co. KG. Copies may be made for the user's internal purposes. Suggestions and comments for improving this documentation will be gratefully received.

Pilz®, PIT®, PMI®, PNOZ®, Primo®, PSEN®, PSS®, PVIS®, SafetyBUS p®, SafetyEYE®, SafetyNET p®, the spirit of safety® are registered and protected trademarks of Pilz GmbH & Co. KG in some countries.



SD means Secure Digital

1	Introduction	4
1.1	Validity of documentation	4
1.2	Using the documentation	4
1.3	Definition of symbols	4
2	Overview	6
2.1	Module features	6
3	Safety	7
3.1	Intended use	7
3.2	System requirements	7
3.3	Safety regulations	8
3.3.1	Use of qualified personnel	8
3.3.2	Warranty and liability	8
3.3.3	Disposal	8
4	Function description	9
4.1	Block diagram	9
4.2	Supply	9
4.3	Inputs	9
4.4	Reaction times	14
4.5	Energy-saving functions	14
5	Address assignment	15
6	Installation	16
6.1	General installation guidelines	16
6.1.1	Dimensions	16
6.2	Inserting and removing an electronic module	17
6.2.1	Inserting an electronic module	17
6.2.2	Removing an electronic module	19
6.2.3	Changing an electronic module during operation	20
7	Wiring	21
7.1	General wiring guidelines	21
7.1.1	Connection mechanism for terminal blocks	21
7.2	Terminal configuration	21
8	Operation	22
8.1	Display elements and messages	22
9	Technical details	24
10	Order reference	26
10.1	Product	26
10.2	Accessories	26

1 Introduction

1.1 Validity of documentation

This operating manual explains the function and operation, describes the installation and provides guidelines on how to connect the product.

This documentation is valid for the product PSS u2 ES 8DI hardware version 01 or higher. It is valid until new documentation is published.

1.2 Using the documentation

This document is intended for instruction. Only install and commission the product if you have read and understood this document. The document should be retained for future reference.

Please refer to the PSS u2 Installation Manual.

1.3 Definition of symbols

Information that is particularly important is identified as follows:



DANGER!

This warning must be heeded! It warns of a hazardous situation that poses an immediate threat of serious injury and death and indicates preventive measures that can be taken.



WARNING!

This warning must be heeded! It warns of a hazardous situation that could lead to serious injury and death and indicates preventive measures that can be taken.



CAUTION!

This refers to a hazard that can lead to a less serious or minor injury plus material damage, and also provides information on preventive measures that can be taken.



NOTICE

This describes a situation in which the product or devices could be damaged and also provides information on preventive measures that can be taken. It also highlights areas within the text that are of particular importance.



INFORMATION

This gives advice on applications and provides information on special features.

2 Overview

Module structure:

A module consists of

- ▶ an electronic module,
- ▶ a terminal block with cage clamp terminals and
- ▶ a module carrier

The electronic modules are plugged into the backplane and determine the function. The backplane is used for communication between the head module and the electronic modules and forms the carrier unit for the electronic modules. The terminal block is plugged into the electronic modules and is used to connect the field wiring.

Details of the terminal blocks that can be used are available under "Intended Use".

2.1 Module features

Application of the product PSS u2 ES 8DI:

Electronic module with digital inputs for standard applications

The product has the following features:

- ▶ 8 type 3 digital inputs in accordance with IEC 61131-2
- ▶ Configurable input filter time: 0 ... 25.5 [ms]
- ▶ Configurable pulse stretching: 0 ... 255 [ms]
- ▶ Energy-saving functions
- ▶ LEDs for:
 - Status of inputs
 - Module error
 - Operating status

3 Safety

3.1 Intended use

The module provides standard type 3 inputs in accordance with IEC 61131-2 and may be used for standard applications in the PSS u2 system.

Intended use includes making the electrical installation EMC-compliant. The module is designed for use in an industrial environment. Interference may occur if used in other areas.

The following is deemed improper use in particular

- ▶ Any component, technical or electrical modification to the module,
- ▶ Use of the module outside the areas described in this manual,
- ▶ Any use of the module that is not in accordance with the technical details.

The module PSS u2 ES 8DI may be used in conjunction with the following terminal block:

- ▶ 8-pin terminal block

3.2 System requirements



INFORMATION

The module is supported by

- ▶ PASconfig from version 1.0.0
 - We recommend that you always use the latest version (download from www.pilz.com).

3.3 Safety regulations

3.3.1 Use of qualified personnel

The products may only be assembled, installed, programmed, commissioned, operated, maintained and decommissioned by persons who are competent to do so.

A competent person is a qualified and knowledgeable person who, because of their training, experience and current professional activity, has the specialist knowledge required. To be able to inspect, assess and operate devices, systems and machines, the person has to be informed of the state of the art and the applicable national, European and international laws, directives and standards.

It is the company's responsibility only to employ personnel who

- ▶ Are familiar with the basic regulations concerning health and safety / accident prevention,
- ▶ Have read and understood the information provided in the section entitled Safety
- ▶ Have a good knowledge of the generic and specialist standards applicable to the specific application.

3.3.2 Warranty and liability

All claims to warranty and liability will be rendered invalid if

- ▶ The product was used contrary to the purpose for which it is intended,
- ▶ Damage can be attributed to not having followed the guidelines in the manual,
- ▶ Operating personnel are not suitably qualified,
- ▶ Any type of modification has been made (e.g. exchanging components on the PCB boards, soldering work etc.).

3.3.3 Disposal

- ▶ When decommissioning, please comply with local regulations regarding the disposal of electronic devices (e.g. Electrical and Electronic Equipment Act).

4 Function description

4.1 Block diagram

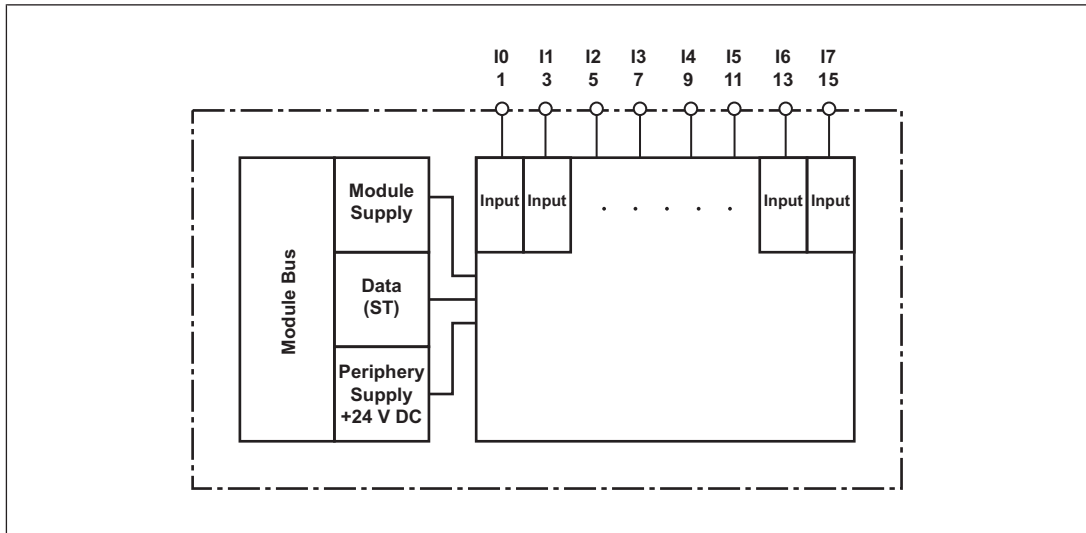

Fig.: Block diagram PSS u2 ES 8DI

4.2 Supply

- ▶ The module is supplied with voltage via the head module.

4.3 Inputs

- ▶ The status of the inputs is signalled to the head module via the module bus.
- ▶ The inputs are fitted with a configurable software filter.
- ▶ Pulse stretching can be configured for the inputs.
- ▶ Any signals that are shorter than the signal suppression time $t_{\text{pulse_sup}}$ are filtered out. The signal suppression time depends on the configured software filter time.

$$t_{\text{pulse_sup}} = t_{\text{filter}} - 300 \mu\text{s}$$

- ▶ The module detects any signals that are present at the input for longer than the minimum signal time $t_{\text{signal_min}}$.

$$t_{\text{signal_min}} = t_{\text{filter}} + t_{\text{ProclM}}$$

t_{ProclM} : Input processing time (see [Technical details](#) [ 24]).

- ▶ A signal is always detected and signalled to the head module's PII if it is present for longer than the sum of the following times:
 - Minimum signal time $t_{\text{signal_min}}$
 - ST scan time

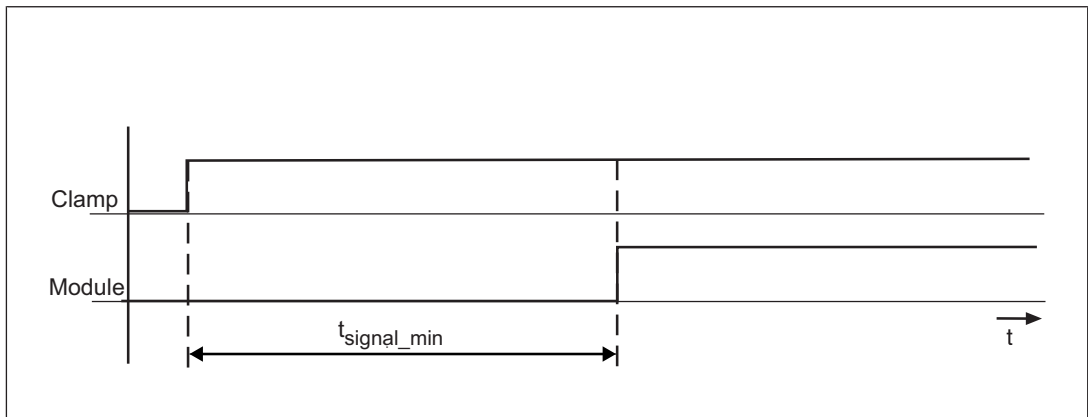

Fig.: Software filter

Legend

Clamp Signal at the terminal

Module Filtered signal in the module

$t_{\text{signal_min}}$ Time for which a signal must be present at the input in order to be detected

Pulse stretching:

The module stretches a 1-signal or 0-signal at the input terminals to the configured pulse stretch time $t_{stretch}$. If the signal is longer than the pulse stretch time, then it is not stretched any further.

Signal requirements at the terminals:

The 0-signal and the subsequent 1-signal together must be present at the input for longer than twice the configured pulse stretch time $t_{stretch}$.

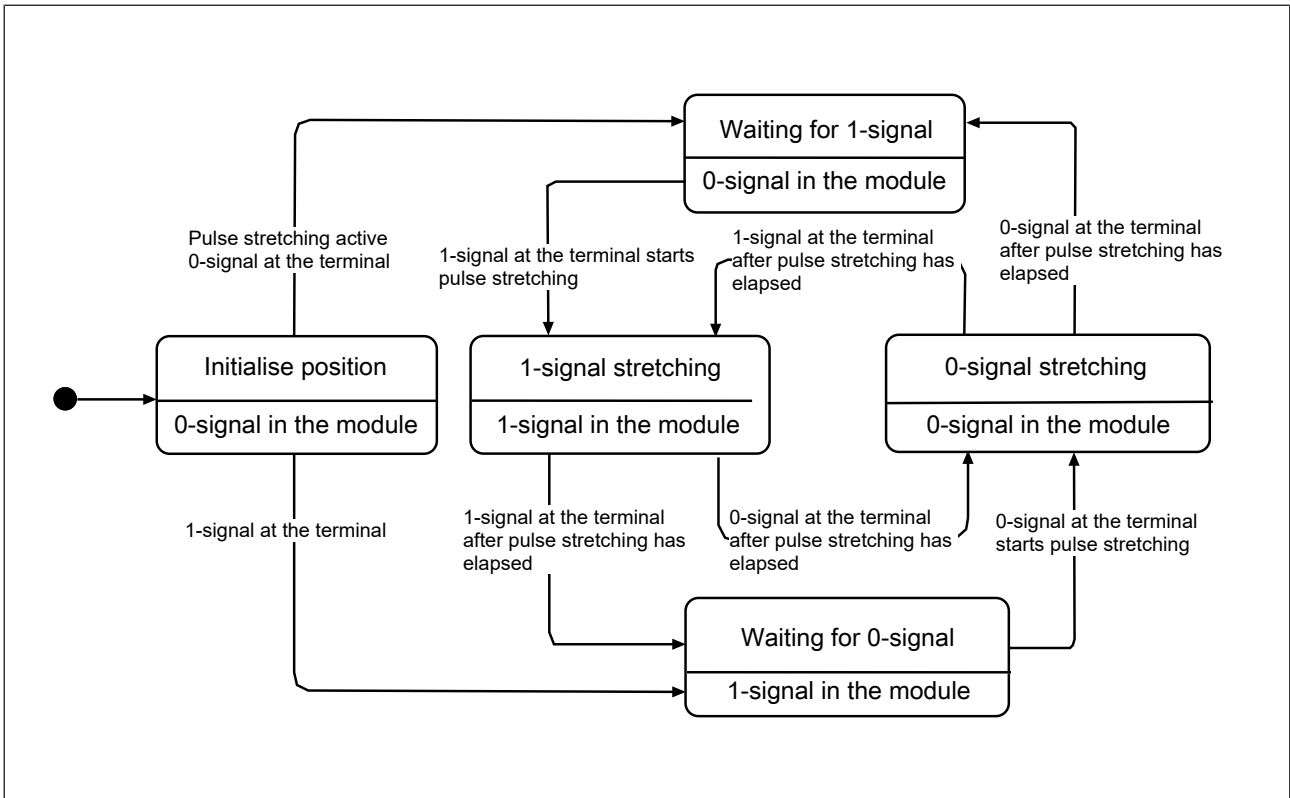

Fig.: States for pulse stretching

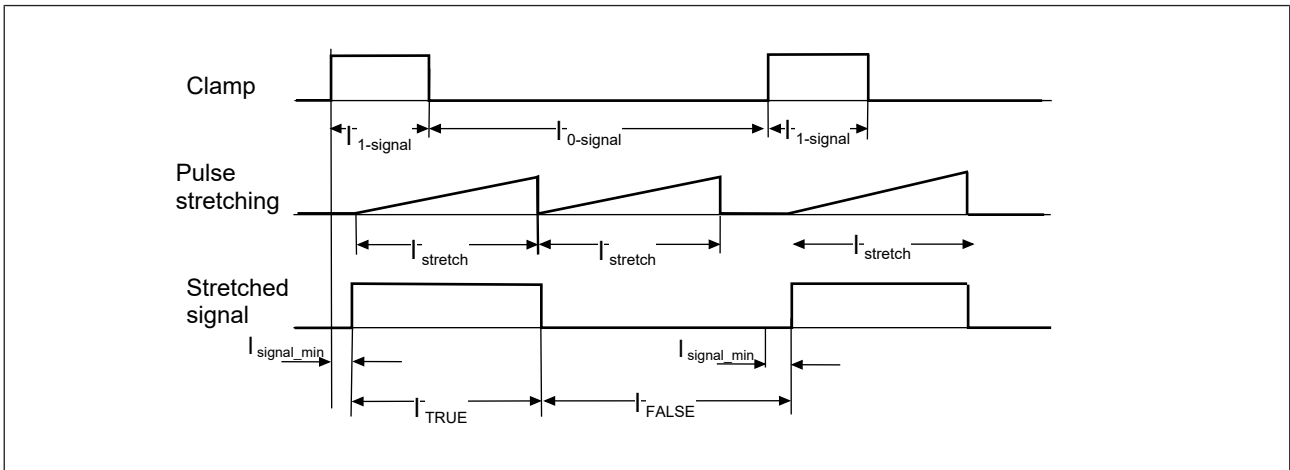

Fig.: Timing diagram: pulse stretching > signal duration of 1-signal

Legend

Clamp Signal at the terminal

Pulse stretching Pulse stretching

Stretched signal Stretched signal

$t_{1\text{-signal}}$ Duration of 1-signal

t_{stretch} Duration of pulse stretching

$t_{\text{signal_min}}$ Time for which a signal must be present at the input in order to be detected

t_{TRUE} Stretched 1-signal in the module

t_{FALSE} Stretched 0-signal in the module

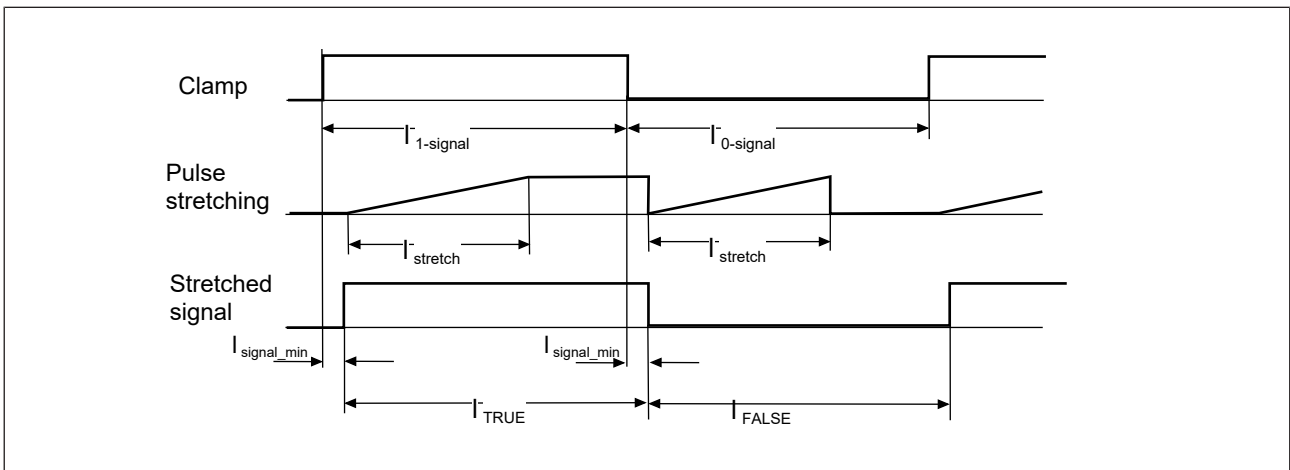

Fig.: Timing diagram: pulse stretching \leq signal duration of 1-signal

Legend

Clamp Signal at the terminal

Pulse stretching Pulse stretching

Stretched signal Stretched signal

$t_{1\text{-signal}}$ Duration of 1-signal

t_{stretch} Duration of pulse stretching

- $t_{\text{signal_min}}$ Time for which a signal must be present at the input in order to be detected
- t_{TRUE} Stretched 1-signal in the module
- t_{FALSE} Stretched 0-signal in the module

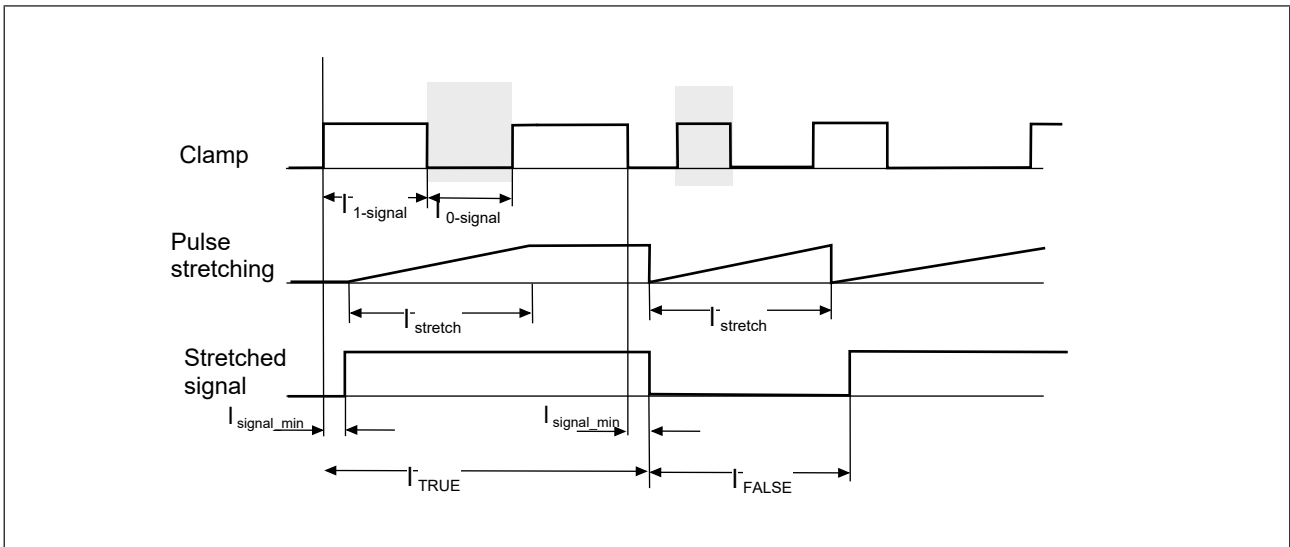

Fig.: Timing diagram: pulse stretching with variable signal duration

Legend

- Clamp Signal at the terminal
- Pulse stretching Pulse stretching
- Stretched signal Stretched signal
- $t_{1\text{-signal}}$ Duration of 1-signal
- t_{stretch} Duration of pulse stretching
- $t_{\text{signal_min}}$ Time for which a signal must be present at the input in order to be detected
- t_{TRUE} Stretched 1-signal in the module
- t_{FALSE} Stretched 0-signal in the module
- Grey shaded Signals that are not detected during stretching area

4.4 Reaction times

Detailed information on the reaction times is available in the operating manual of the head modules.

4.5 Energy-saving functions

The energy-saving levels are controlled by the head module and are not configurable. The module supports the following energy-saving levels:

▶ Switching off the LEDs

The LEDs have two energy-saving levels:

- Switching off the LEDs to display the terminal status
- Switching off the LEDs to display the module and terminal status

▶ Standby mode

- All module functions are inactive.
- The LEDs for displaying the module and terminal status are switched off.

5 Address assignment

The module occupies 1 Byte in the process image of inputs.

PII	Meaning	State
Bit 0	Input data I0	0: "0"-signal (0 V) at the input 1: "1"-signal (+ 24 V) at the input
Bit 1	Input data I1	
Bit 2	Input data I2	
Bit 3	Input data I3	
Bit 4	Input data I4	
Bit 5	Input data I5	
Bit 6	Input data I6	
Bit 7	Input data I7	

6 Installation

6.1 General installation guidelines



NOTICE

Damage due to electrostatic discharge!

Electrostatic discharge can damage components. Ensure against discharge before touching the product, e.g. by touching an earthed, conductive surface or by wearing an earthed armband.

6.1.1 Dimensions

The dimensions include the backplane, electronic module and terminal block.

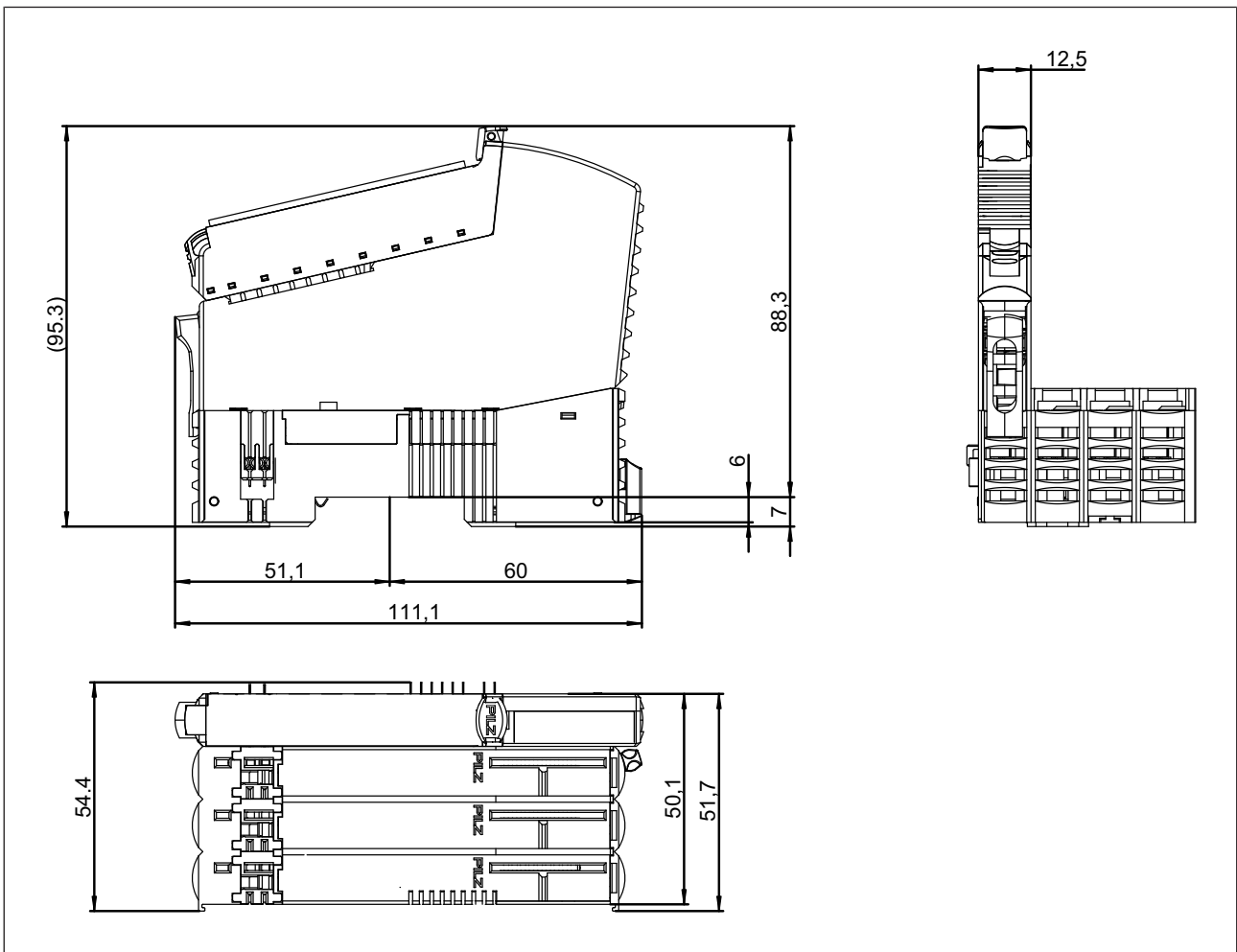

Fig.: Dimensions in mm, including backplane, electronic module and terminal block

6.2 Inserting and removing an electronic module

Please note:

- ▶ Backplane must be installed first.
- ▶ Electronic modules may only be plugged or unplugged if the terminal block has been removed first.
- ▶ The mechanics of the electronic modules are designed for 20 plug in/out cycles.

6.2.1 Inserting an electronic module

1. Insert the electronic module into the suspension lug on the backplane.

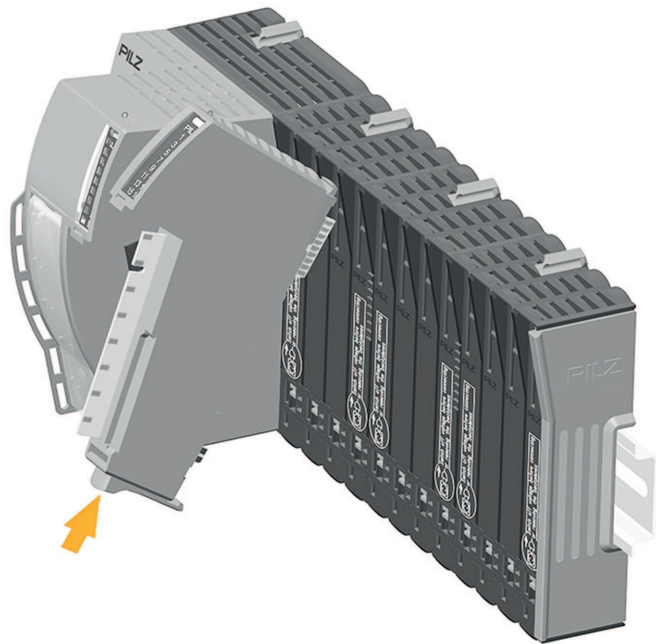

2. Swivel the electronic module downwards until you hear it click into place.

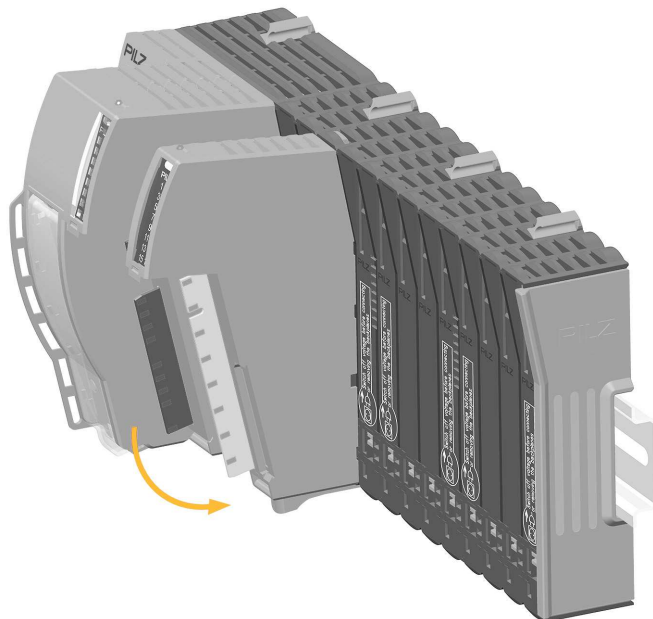

3. Insert the terminal block into the suspension lug on the module.

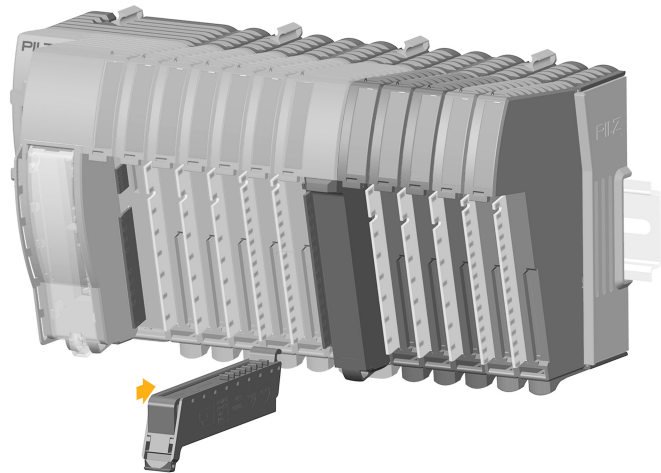

4. Swivel the terminal block upwards until you hear it click into place.

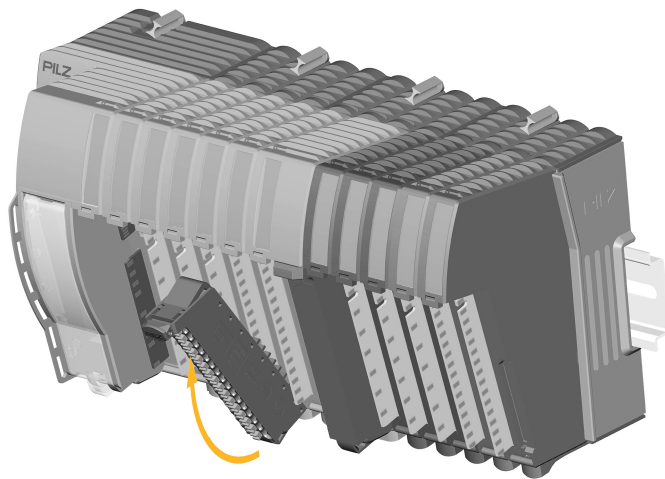

6.2.2 Removing an electronic module

1. Press the unlocking mechanism on the terminal block that is shown by the arrow and pull off the terminal block forward.

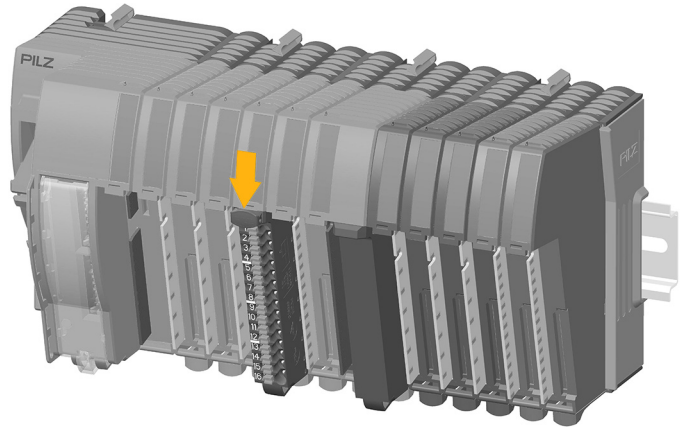

2. Press the unlocking mechanism that is shown by the arrow and pull off the electronic module upwards.

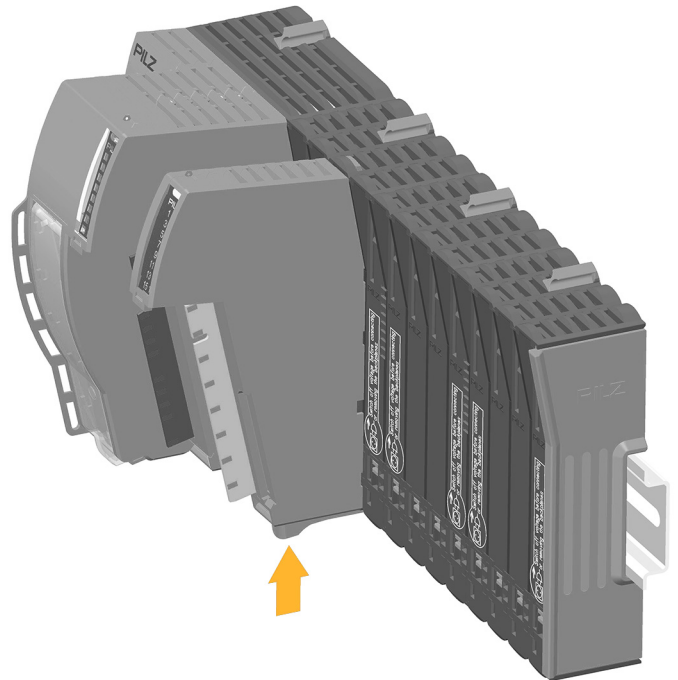



6.2.3 Changing an electronic module during operation

An electronic module can be hot swapped.

Effects:

- ▶ Module bus communication between the other modules is not interrupted.
- ▶ The configuration data is retained.
- ▶ The module is detected automatically as soon as the module is re-inserted.

Procedure:

1. [Removing an electronic module](#)  19]
2. [Inserting an electronic module](#)  17]

A new electronic module can be inserted during operation.

Procedure:

- ▶ [Inserting an electronic module](#)  17]

Effects:

- ▶ Module bus communication between the other modules is not interrupted.
- ▶ To detect the new module the following steps can be necessary:
 - Creating a new configuration or changing an existing configuration
 - Download of the configuration to the head module
 - Restart of the head module. After a restart, the system behaves as after a warm reset using a reset pushbutton (see operating manual of the head module, chapter "Reset pushbutton", section "Carrying out a warm reset (restart)").

7 Wiring

7.1 General wiring guidelines

Please note:

- ▶ Signal lines do not have to be shielded.

7.1.1 Connection mechanism for terminal blocks

Procedure:

- ▶ Use a flat head screwdriver.
- ▶ Strip the wire back 9 mm.
- ▶ Feed the stripped cable as far as it will go into the opening for the spring-loaded terminal.
- ▶ Check that the cable is firmly seated.

Please note:

- ▶ The minimum cable cross section for field connection terminals on the terminal blocks is 0.15 mm² (AWG26).
- ▶ The maximum cable cross section for field connection terminals on the terminal blocks is 1.5 mm² with ferrules (AWG14)
- ▶ Use copper wiring.

7.2 Terminal configuration

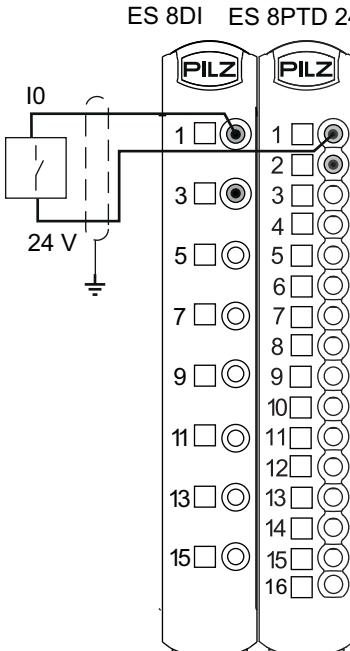
Terminal configuration	Connection example
1: Input I0 3: Input I1 5: Input I2 7: Input I3 9: Input I4 11: Input I5 13: Input I6 15: Input I7	1-channel sensor Sensors supplied via the +24 V periphery supply from the module PSS u2 ES 8PTD 24V 0V 

8 Operation

The status of the module is displayed via a red and a green LED. The status of the terminals is displayed via a green LED. If there is a module error, the module status display will light up red. The error will be signalled to the head module and will be entered in the head module's diagnostic log.

8.1 Display elements and messages

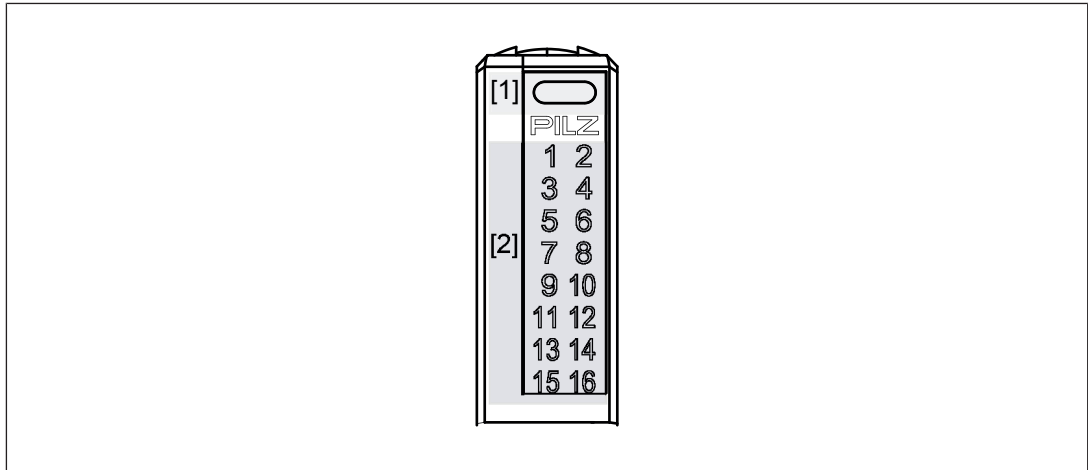

Legend

- [1] Module status display
- [2] Terminal status display

The module can detect the following errors:

[1]	Colour [1]	[2]	Colour [2]	Meaning	Further information
●	--	●	--	Module not ready for operation	
●	Green	●	--	Module ready for operation	
☀	Green	☀	Green	Module in operation and there is a "1"-signal at the input	
	Green	●	--	Module in operation and there is a "0"-signal at the input	
●	Red	●	--	Configuration error Module was inserted in the wrong slot.	
☀	Red	●	--	Internal errors	See module's diagnostic log
●	Red	●	--	Temperature error: Too warm (1)	See module's diagnostic log.
●	Red	●	Green	The module status display and all terminal status displays flash simultaneously Periphery supply is missing/temperature error: Too hot (1)	See module's diagnostic log.

(¹) There are two levels of overtemperature.

▶ Too warm:

If the module temperature exceeds a threshold value, then:

- a warning is sent to the head module.

If the temperature drops back below the threshold value, the module sends an all-clear.

▶ Too hot:

If the module temperature exceeds another threshold value, then:

- an error message is sent to the head module
- the inputs continue to be read and appear in the ST-PII

After the "too hot" message has been received, if the temperature drops back below the "too warm" threshold value, the module will switch to an error-free state.

Legend

- ☀ LED on
- LED flashes
- LED flashes briefly
- LED off

9 Technical details

General	
Certifications	CE, UKCA, cULus Listed
Application range	Standard
Module's device code	0009h
Number of ST input bits	8
Electrical data	
Supply voltage	
Max. power consumption of an input	0,11 W
Internal supply voltage (module supply)	
Module's power consumption	0,15 W
Max. power dissipation of module	1,1 W
Inputs	
Number	8
Signal level at "0"	-3 - +5 V DC
Signal level at "1"	11 - 30 V DC
Voltage at inputs	24 V DC
Input type in accordance with EN 61131-2	3
Input current range	3 - 3,5 mA
Max. processing time of input when signal changes from "1" to "0"	0,3 ms
Max. processing time of input when signal changes from "0" to "1"	0,3 ms
Min. processing time of input when signal changes from "1" to "0"	0,005 ms
Min. processing time of input when signal changes from "0" to "1"	0,005 ms
Software filter time	0 ms ... 25,5 ms
Potential isolation	yes
Environmental data	
Climatic suitability	EN 60068-2-1, EN 60068-2-14, EN 60068-2-2, EN 60068-2-30, EN 60068-2-78
Ambient temperature	
In accordance with the standard	EN 60068-2-14
Temperature range	0 - 60 °C
Storage temperature	
In accordance with the standard	EN 60068-2-1/-2
Temperature range	-40 - 70 °C
Climatic suitability	
In accordance with the standard	EN 60068-2-78
Humidity	93 % r. h. at 40 °C
Condensation during operation	Not permitted
Max. operating height above sea level	2000 m
EMC	EN 61131-2 (Zone B)

Environmental data

Vibration

In accordance with the standard	EN 60068-2-6
Frequency	8,4 - 150 Hz
Acceleration	10 m/s²

Shock stress

In accordance with the standard	EN 60068-2-27
Acceleration	150 m/s²
Duration	11 ms

Airgap creepage

In accordance with the standard	EN 61131-2, UL/IEC 61010-2-201
Overvoltage category	II
Pollution degree	2

Protection type

In accordance with the standard	EN 60529
Housing	IP20
Mounting area (e.g. control cabinet)	IP54

Potential isolation

Potential isolation between	Input and module supply
Type of potential isolation	Functional insulation
Rated surge voltage	2500 V

Mechanical data

Material

Housing	PC
---------	-----------

Mounting type

plug-in

Dimensions

Height	110,8 mm
Width	12,5 mm
Depth	72,5 mm

Weight

30 g

Where standards are undated, the 2015-04 latest editions shall apply.

10 Order reference

10.1 Product

Product type	Features	Order no.
PSS u2 E S 8DI	Electronic module	328301

10.2 Accessories

Terminal block

Product type	Features	Order no.
PSS u2 T 8 (1 pc.)	Terminal block 8-pin, scope of supply: 1 pieces	328840
PSS u2 T 8 (10 pcs.)	Terminal block 8-pin, scope of supply: 10 pieces	328841
PSS u2 T 8 (5 x 10 pcs.)	Terminal block 8-pin, scope of supply: 50 pieces	328842

Labelling bracket

Product type	Features	Order No.
PSS u2 A LC E1 (10 pcs.)	Labelling bracket for electronic module 23.5 x 10.5 mm, scope of delivery: 10 pieces	328910
PSS u2 A LC E2 (10 pcs.)	Labelling bracket for electronic module 103 x 10.5 mm, scope of delivery: 10 pieces	328911
PSS u2 A LA E1 (10 pcs.)	Labelling strips for electronic module 23.5 x 10.5 mm (10 x DIN A4 sheet)	328913
PSS u2 A LA E2 (10 pcs.)	Labelling strips for electronic module 103 x 10.5 mm (10 x DIN A4 sheet)	328914

Label holder for terminal block

Product type	Features	Order no.
PSS u2 A LC T3 (10 pcs.)	Label holder for terminal block 61 x 11.5 mm, scope of supply: 10 pieces	328912

Coding elements

Product type	Features	Order no.
PSS u2 A CE E (10 pcs.)	Coding elements for electronic modules, scope of supply: 10 pieces	328860

Backplanes

Product type	Features	Order no.
PSS u2 B 1	Backplane, 1 slot	328811
PSS u2 B 4	Backplane, 4 slots	328810

