



PSS u2 ES 4DO SR 0.5A

PILZ
THE SPIRIT OF SAFETY

- ▶ Control system PSS u2
- ▶ Remote I/O system PSS u2

This document is the original document.

Where unavoidable, for reasons of readability, the masculine form has been selected when formulating this document. We do assure you that all persons are regarded without discrimination and on an equal basis.

All rights to this documentation are reserved by Pilz GmbH & Co. KG. Copies may be made for the user's internal purposes. Suggestions and comments for improving this documentation will be gratefully received.

Pilz®, PIT®, PMI®, PNOZ®, Primo®, PSEN®, PSS®, PVIS®, SafetyBUS p®, SafetyEYE®, SafetyNET p®, the spirit of safety® are registered and protected trademarks of Pilz GmbH & Co. KG in some countries.



SD means Secure Digital

1	Introduction	4
1.1	Validity of documentation	4
1.2	Using the documentation	4
1.3	Definition of symbols	4
2	Overview	6
2.1	Module features	6
3	Safety	7
3.1	Intended use	7
3.2	System requirements	7
3.3	Safety regulations	7
3.3.1	Use of qualified personnel	7
3.3.2	Warranty and liability	8
3.3.3	Disposal	8
4	Function description	9
4.1	Block diagram	9
4.2	Supply	9
4.3	Integrated protection mechanisms	9
4.4	Outputs	9
4.5	Reaction times	10
4.6	Energy-saving functions	10
5	Address assignment	11
6	Installation	12
6.1	General installation guidelines	12
6.1.1	Dimensions	12
6.2	Inserting and removing an electronic module	13
6.2.1	Inserting an electronic module	13
6.2.2	Removing an electronic module	15
6.2.3	Changing an electronic module during operation	15
7	Wiring	17
7.1	General wiring guidelines	17
7.1.1	Connection mechanism for terminal blocks	17
7.2	Terminal configuration	18
8	Operation	19
8.1	Display elements and messages	19
9	Technical Details	21
9.1	Service life graphs	23
10	Order reference	24
10.1	Product	24
10.2	Accessories	24

1 Introduction

1.1 Validity of documentation

This operating manual explains the function and operation, describes the installation and provides guidelines on how to connect the product.

This documentation is valid for the product PSS u2 ES 4DO SR 0.5A hardware version 01 or higher. It is valid until new documentation is published.

1.2 Using the documentation

This document is intended for instruction. Only install and commission the product if you have read and understood this document. The document should be retained for future reference.

Please refer to the PSS u2 Installation Manual.

1.3 Definition of symbols

Information that is particularly important is identified as follows:



DANGER!

This warning must be heeded! It warns of a hazardous situation that poses an immediate threat of serious injury and death and indicates preventive measures that can be taken.



WARNING!

This warning must be heeded! It warns of a hazardous situation that could lead to serious injury and death and indicates preventive measures that can be taken.



CAUTION!

This refers to a hazard that can lead to a less serious or minor injury plus material damage, and also provides information on preventive measures that can be taken.



NOTICE

This describes a situation in which the product or devices could be damaged and also provides information on preventive measures that can be taken. It also highlights areas within the text that are of particular importance.



INFORMATION

This gives advice on applications and provides information on special features.

2 Overview

Module structure:

A module consists of

- ▶ an electronic module,
- ▶ a terminal block with cage clamp terminals and
- ▶ a module carrier

The electronic modules are plugged into the backplane and determine the function. The backplane is used for communication between the head module and the electronic modules and forms the carrier unit for the electronic modules. The terminal block is plugged into the electronic modules and is used to connect the field wiring.

Details of the terminal blocks that can be used are available under "Intended Use".

2.1 Module features

Application of the product PSS u2 ES 4DO SR 0.5A:

Electronic module with changeover contacts for standard applications

The product has the following features:

- ▶ Energy-saving functions
- ▶ LEDs for:
 - Switch status of each output
 - Module error
- ▶ 4 relay contacts
 - N/O contact
 - Volt-free
 - Current load capacity per output: See chapter [Service life graphs](#) [ 23]

3 Safety

3.1 Intended use

The module provides relay outputs with changeover contacts. It may be used to switch extra low voltages of up to 30 V DC.

The module PSS u2 ES 4DO SR 0.5A may be used in conjunction with the following terminal block:

- ▶ 16-pin terminal block

Intended use includes making the electrical installation EMC-compliant. The module is designed for use in an industrial environment. Interference may occur if used in other areas.

The following is deemed improper use in particular

- ▶ Any component, technical or electrical modification to the module,
- ▶ Use of the module outside the areas described in this manual,
- ▶ Any use of the module that is not in accordance with the technical details.

3.2 System requirements



INFORMATION

The module is supported by

- ▶ PASconfig from version 2.0.0
 - We recommend that you always use the latest version (download from www.pilz.com).

3.3 Safety regulations

3.3.1 Use of qualified personnel

The products may only be assembled, installed, programmed, commissioned, operated, maintained and decommissioned by competent persons.

A competent person is a qualified and knowledgeable person who, because of their training, experience and current professional activity, has the specialist knowledge required. To be able to inspect, assess and operate devices, systems and machines, the person has to be informed of the state of the art and the applicable national, European and international laws, directives and standards.

It is the company's responsibility only to employ personnel who

- ▶ Are familiar with the basic regulations concerning health and safety / accident prevention,
- ▶ Have read and understood the information provided in the section entitled Safety
- ▶ Have a good knowledge of the generic and specialist standards applicable to the specific application.

3.3.2 Warranty and liability

All claims to warranty and liability will be rendered invalid if

- ▶ The product was used contrary to the purpose for which it is intended,
- ▶ Damage can be attributed to not having followed the guidelines in the manual,
- ▶ Operating personnel are not suitably qualified,
- ▶ Any type of modification has been made (e.g. exchanging components on the PCB boards, soldering work etc.).

3.3.3 Disposal

- ▶ When decommissioning, please comply with local regulations regarding the disposal of electronic devices (e.g. Electrical and Electronic Equipment Act).

4 Function description

4.1 Block diagram

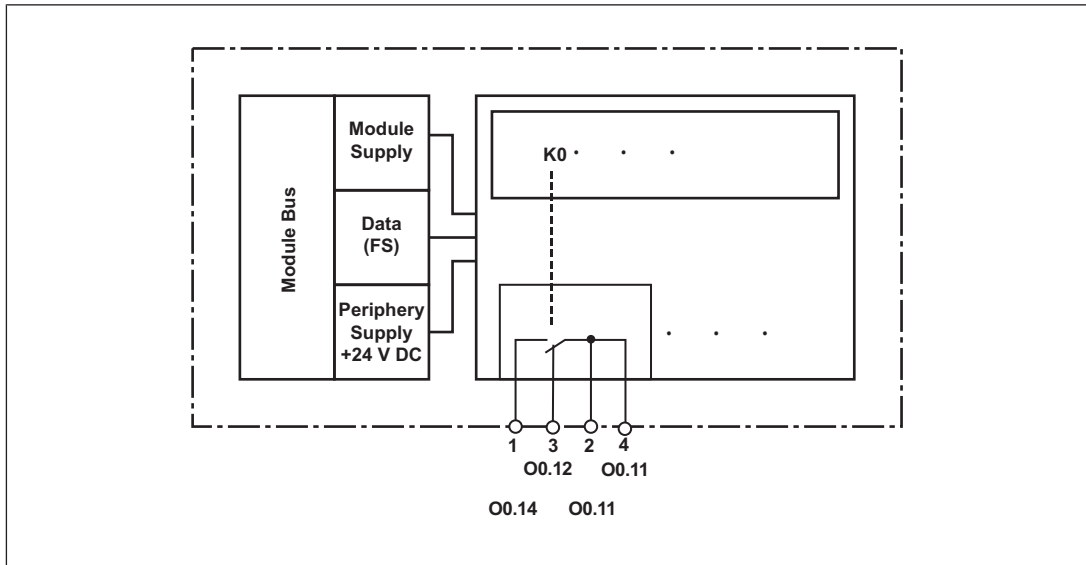

Fig.: Block diagram PSS u2 ES 4DO SR 0.5A

4.2 Supply

- ▶ The module is supplied with voltage via the head module.

4.3 Integrated protection mechanisms

- ▶ The module has temperature monitoring.

The module provides the following diagnostic data:

- ▶ Start-up error
- ▶ Configuration error
- ▶ ST communication error
- ▶ Temperature error: too warm
- ▶ Temperature error: too hot

4.4 Outputs

The module has 4 relay outputs with a changeover contact.

Outputs

- ▶ The head module sets the output status via the module bus.

If the module does not receive a process image of outputs from the head module, then substitute values are used for the process data. The value that is to be used as the substitute value can be configured.

Substitute values may be:

- ▶ Output switched off (default value)
- ▶ Output switched on

- ▶ Last valid value

4.5 Reaction times

Detailed information on the reaction times is available in the operating manual of the head modules.

4.6 Energy-saving functions

The energy-saving levels are controlled by the head module and are not configurable. The module supports the following energy-saving levels:

- ▶ Switching off the LEDs

The LEDs have two energy-saving levels:

- Switching off the LEDs that display the terminal status
- Switching off the LEDs that display the module and terminal status

- ▶ Switching off the relay coils

- ▶ Standby mode

- All module functions are inactive.
- The LEDs for displaying the module and terminal status are switched off.

5 Address assignment

The module occupies 1 Byte in the process image of outputs.

PIO	Meaning	State
Bit 0	Output data O0 Changeover contact O0.12/ O0.11 Changeover contact O0.14/ O0.11	0: Changeover contact O0.12 and O0.11 is closed 1: Changeover contact O0.14 and O0.11 is closed
Bit 1	Output data O1 Changeover contact O1.22/ O1.21 Changeover contact O1.24/ O1.21	0: Changeover contact O1.22 and O1.21 is closed 1: Changeover contact O1.24 and O1.21 is closed
Bit 2	Output data O2 Changeover contact O2.32/ O2.31 Changeover contact O2.34/ O2.31	0: Changeover contact O2.32 and O2.31 is closed 1: Changeover contact O2.34 and O2.31 is closed
Bit 3	Output data O3 Changeover contact O3.42/ O3.41 Changeover contact O3.44/ O3.41	0: Changeover contact O3.42 and O3.41 is closed 1: Changeover contact O3.44 and O3.41 is closed
Bit 4-7	None	Permanently "0"

6 Installation

6.1 General installation guidelines



NOTICE

Damage due to electrostatic discharge!

Electrostatic discharge can damage components. Ensure against discharge before touching the product, e.g. by touching an earthed, conductive surface or by wearing an earthed armband.

6.1.1 Dimensions

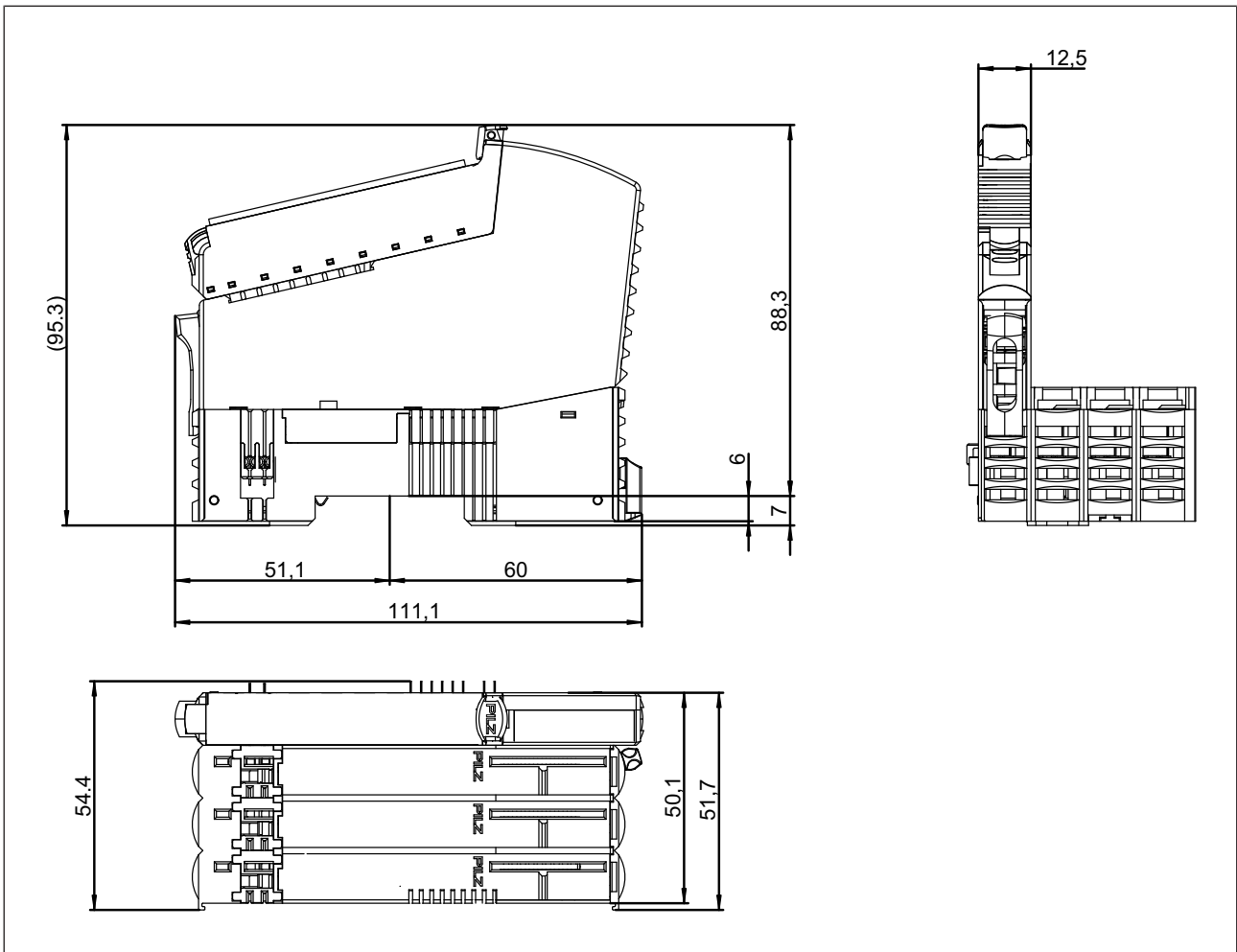

Fig.: Dimensions in mm, including backplane, electronic module and terminal block

6.2 Inserting and removing an electronic module

Please note:

- ▶ Backplane must be installed first.
- ▶ Electronic modules may only be plugged or unplugged if the terminal block has been removed first.
- ▶ The mechanics of the electronic modules are designed for 20 plug in/out cycles.
- ▶ On electronic modules with outputs, the terminal block may only be inserted and removed when the load is switched off. Unforeseeable error reactions may be triggered if modules are inserted and removed under load.

6.2.1 Inserting an electronic module

1. Insert the electronic module into the suspension lug on the backplane.

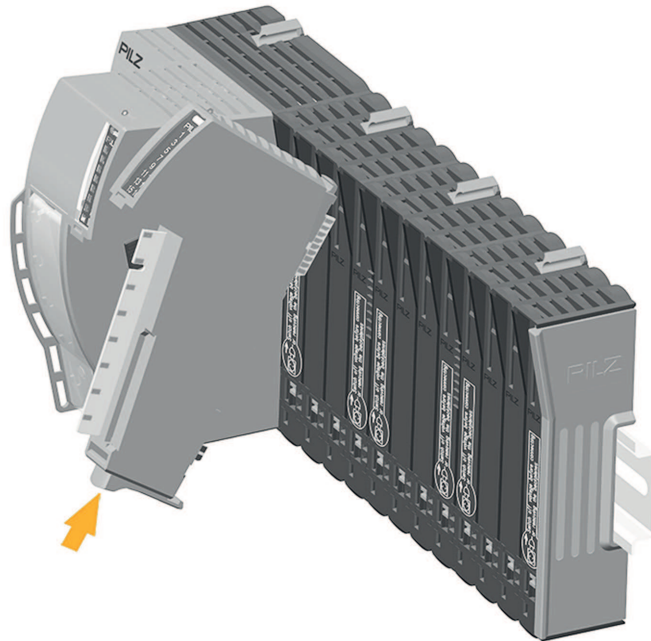

2. Swivel the electronic module downwards until you hear it click into place.

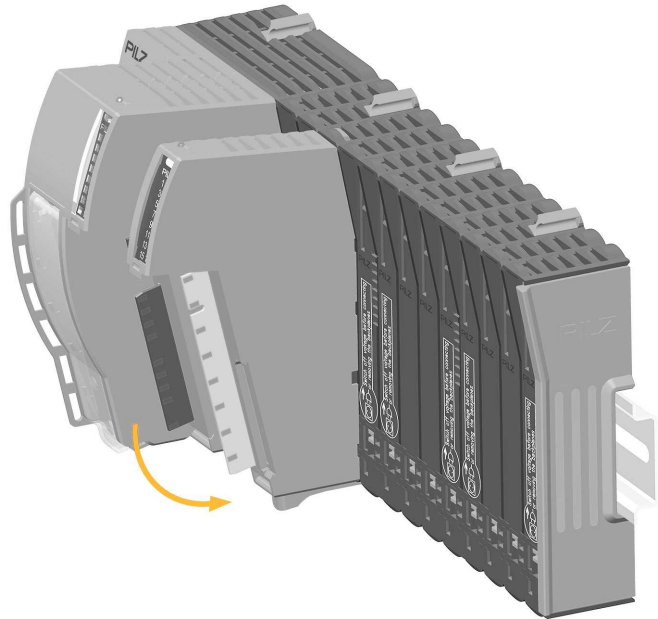

3. Insert the terminal block into the suspension lug on the module.

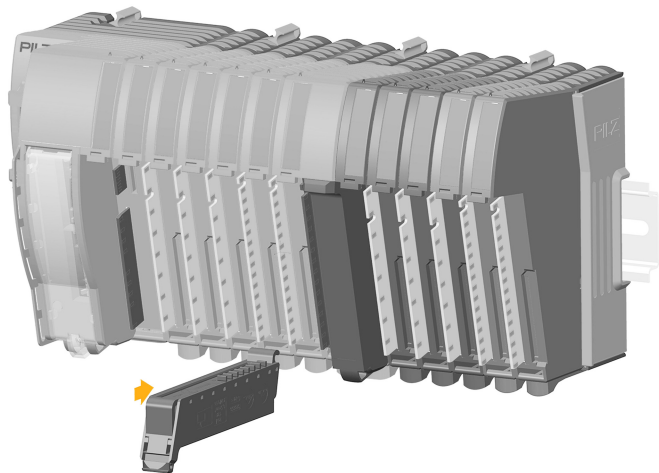

4. Swivel the terminal block upwards until you hear it click into place.

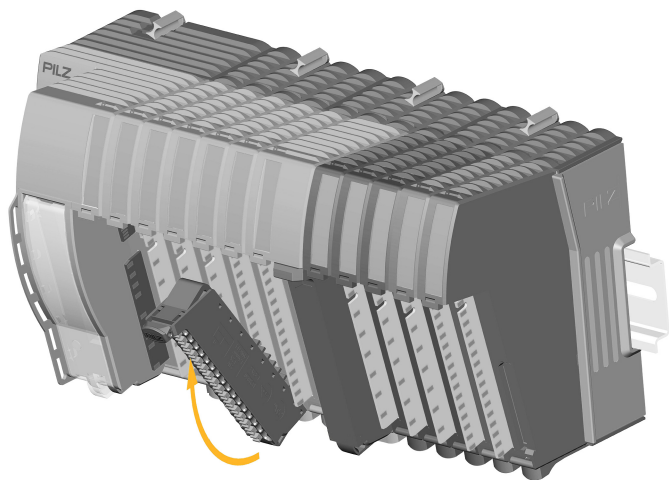

6.2.2 Removing an electronic module

1. Press the unlocking mechanism on the terminal block that is shown by the arrow and pull off the terminal block forward.

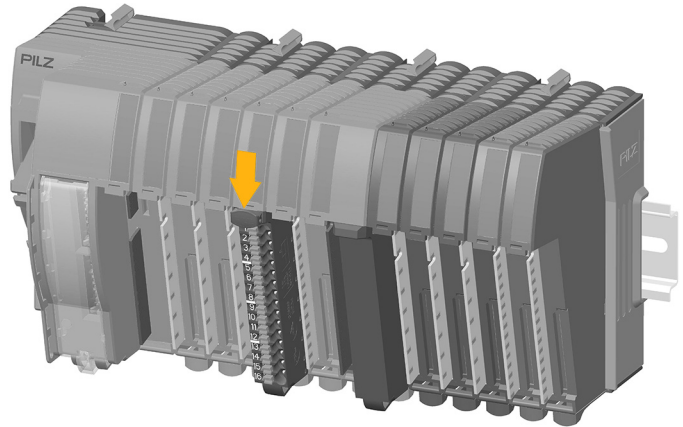

2. Press the unlocking mechanism that is shown by the arrow and pull off the electronic module upwards.

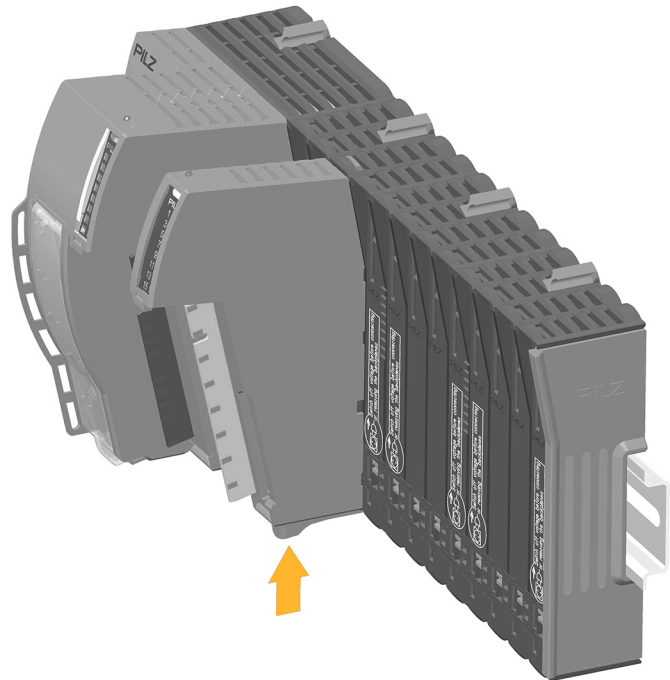

6.2.3 Changing an electronic module during operation

An electronic module can be hot swapped.

Effects:

- ▶ Module bus communication between the other modules is not interrupted.
- ▶ The configuration data is retained.
- ▶ The module is detected automatically as soon as the module is re-inserted.

Procedure:

1. Removing an electronic module
2. Inserting an electronic module

A new electronic module can be inserted during operation.

Procedure:

- ▶ Inserting an electronic module

Effects:

- ▶ Module bus communication between the other modules is not interrupted.
- ▶ To detect the new module the following steps can be necessary:
 - Creating a new configuration or changing an existing configuration
 - Download of the configuration to the head module
 - Restart of the head module. After a restart, the system behaves as after a warm reset using a reset pushbutton (see operating manual of the head module, chapter "Reset pushbutton", section "Carrying out a warm reset (restart)").
- ▶ On electronic modules with outputs, the terminal block may only be inserted and removed when the load is switched off. Unforeseeable error reactions may be triggered if modules are inserted and removed under load.

7 Wiring

7.1 General wiring guidelines

Please note:

- ▶ The actuators may be connected using unshielded cables.
- ▶ To prevent contact welding, a fuse should be connected before the output contacts (see Technical details).
- ▶ Use copper wiring.

7.1.1 Connection mechanism for terminal blocks

Procedure:

- ▶ Use a flat head screwdriver.
- ▶ Strip the wire back 9 mm.
- ▶ Feed the stripped cable as far as it will go into the opening for the spring-loaded terminal.
- ▶ Check that the cable is firmly seated.

Please note:

- ▶ The minimum cable cross section for field connection terminals on the terminal blocks is 0.15 mm² (AWG26).
- ▶ The maximum cable cross section for field connection terminals on the terminal blocks is 1.5 mm² with ferrules (AWG14)
- ▶ Use copper wiring.

7.2 Terminal configuration

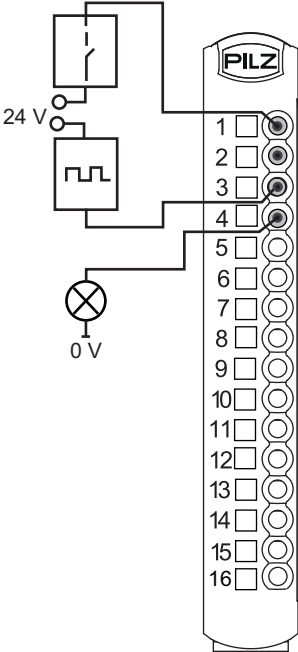
Terminal configuration	Connection examples
<p>Output O0</p> <p>Terminal 1: O0.14</p> <p>Terminal 2: O0.11</p> <p>Terminal 3: O0.12</p> <p>Terminal 4: O0.11</p> <p>Changeover contact 1: O0.12 - O0.11</p> <p>Changeover contact 2: O0.14 - O0.11</p> <p>Output O1</p> <p>Terminal 5: O1.24</p> <p>Terminal 6: O1.21</p> <p>Terminal 7: O1.22</p> <p>Terminal 8: O1.21</p> <p>Changeover contact 1: O1.22 – O1.21</p> <p>Changeover contact 2: O1.24 – O1.21</p> <p>Output O2</p> <p>Terminal 9: O2.34</p> <p>Terminal 10: O2.31</p> <p>Terminal 11: O2.32</p> <p>Terminal 12: O2.31</p> <p>Changeover contact 1: O2.32 – O2.31</p> <p>Changeover contact 2: O2.34 – O2.31</p> <p>Output O3</p> <p>Terminal 13: O3.44</p> <p>Terminal 14: O3.41</p> <p>Terminal 15: O3.42</p> <p>Terminal 16: O3.41</p> <p>Changeover contact 1: O3.42 – O3.41</p> <p>Changeover contact 2: O3.44 – O3.41</p>	<p>► Switching between a process signal at terminal 1 and a test signal at terminal 3.</p> <p>► A signal lamp at terminal 4 displays the signal</p> 

8 Operation

The status of the module is displayed via a red and a green LED. The status of the terminals is displayed via a green LED. If there is a module error, the module status display will light up red. The error will be signalled to the head module and will be entered in the head module's diagnostic log.

8.1 Display elements and messages

Only the LEDs at the terminals 1, 3, 5, 7, 9, 11, 13, 15 are active. The terminal On.x2 lights in switched-off state and terminal On.x4 lights in switched-on state.

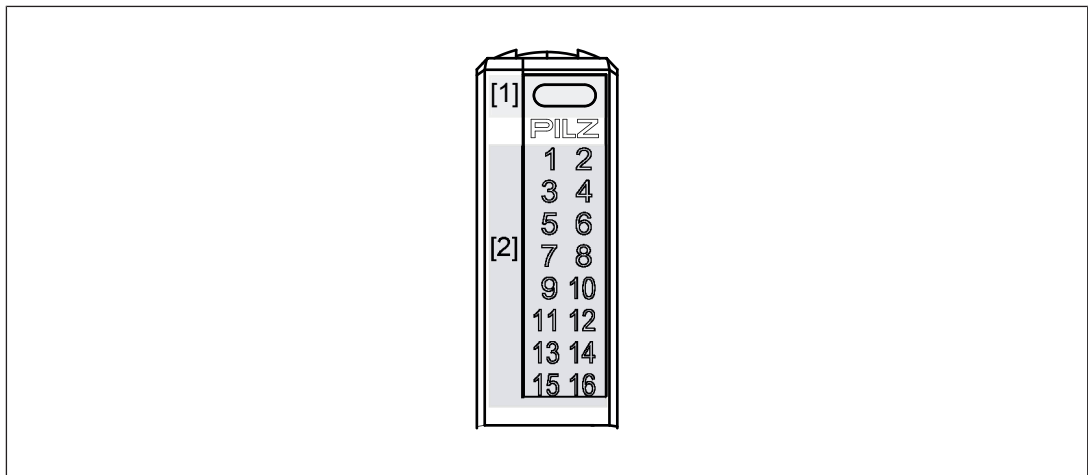









Legend

- [1] Module status display
- [2] Terminal status display

The module can detect the following errors:

[1]	Col-our [1]	[2]	Col-our [2]	Meaning	Further information
●	--	●	--	Module not ready for operation	
●	Green	●	--	Module ready for operation	
☀	Green	☀	Green	Terminal status display at the terminals 3, 7, 11, 15 lights up green when the changeover contact On.x1 / On.x2 is open and the module is in operation. Terminal status display at the terminals 1, 5, 9, 13 lights up green when the changeover contact On.x1 / On.x2 is open and the module is in operation.	
☀	Green	●	--	Module in operation and the changeover contacts are open	
●	Red	●	--	Configuration error: Module was inserted in the wrong slot.	

[1]	Col-our [1]	[2]	Col-our [2]	Meaning	Further information
	Red		--	Internal error/firmware update	See module's diagnostic log
	Red		Green	The module status display and the terminal status display on the relevant output flash synchronously Short circuit/overload/undervoltage	See module's diagnostic log.
	Red	 	Green	Temperature error: too warm (1)/warning, e.g. undervoltage	See module's diagnostic log
	Red		Green	The module status display and all terminal status displays flash synchronously Periphery supply is missing/temperature error: Too hot (1)	See module's diagnostic log

(¹) There are two levels of overtemperature.

► Too warm:

If the module temperature exceeds a threshold value, then:

- a warning is sent to the head module.

If the temperature drops back below the threshold value, the module sends an all-clear.





► Too hot:

If the module temperature exceeds another threshold value, then:

- an error message is sent to the head module
- the outputs are switched off
- The valid bits for the outputs are set to "0"

After the "too hot" message has been received, if the temperature drops back below the "too warm" threshold value, the module will switch to an error-free state.

Legend

-  LED on
-  LED flashes
-  LED flashes briefly
-  LED off

9 Technical Details

General	
Certifications	CE, UKCA, cULus Listed
Application range	Standard
Module's device code	001Dh
Number of ST output bits	4
Electrical data	
Internal supply voltage (module supply)	
Module's power consumption	0,16 W
Periphery's supply voltage (periphery supply)	
Voltage range	16,8 - 30 V
Module's current consumption with no load	40 mA
Module's power consumption with no load	1,2 W
Max. power dissipation of module	1,36 W
Permitted loads	Resistive
Relay outputs	
Number of relay outputs	4
Max. processing time for relay output tProcOM when signal changes from "1" to "0"	10 ms
Max. processing time for relay output tProcOM when signal changes from "0" to "1"	10 ms
Contact material	AgNi
Environmental data	
Climatic suitability	EN 60068-2-1, EN 60068-2-14, EN 60068-2-2, EN 60068-2-30, EN 60068-2-78
Ambient temperature	
In accordance with the standard	EN 60068-2-14
Temperature range	0 - 60 °C
Storage temperature	
In accordance with the standard	EN 60068-2-1/-2
Temperature range	-40 - 70 °C
Climatic suitability	
In accordance with the standard	EN 60068-2-78
Humidity	93 % r. h. at 40 °C
Condensation during operation	Not permitted
Max. operating height above sea level	2000 m
EMC	EN 61131-2 (Zone B)
Vibration	
In accordance with the standard	EN 60068-2-6
Frequency	8,4 - 150 Hz
Acceleration	10 m/s²

Environmental data

Shock stress		
In accordance with the standard		EN 60068-2-27
Acceleration		150 m/s²
Duration		11 ms
Airgap creepage		
In accordance with the standard		EN 61131-2
Overvoltage category		II
Pollution degree		2
Protection type		
In accordance with the standard		EN 60529
Housing		IP20
Mounting area (e.g. control cabinet)		IP54

Potential isolation

Potential isolation between		Relay output and relay output
Type of potential isolation		Functional insulation
Rated surge voltage		1500 V
Potential isolation between		Relay output and periphery supply
Type of potential isolation		Functional insulation
Rated surge voltage		1500 V
Potential isolation between		Relay output and module supply
Type of potential isolation		Functional insulation
Rated surge voltage		2500 V
Potential isolation between		Periphery supply and module supply
Type of potential isolation		Functional insulation
Rated surge voltage		2500 V

Mechanical data

Mechanical life		100,000,000 cycles
Material		
Housing		PC
Mounting type		plug-in
Dimensions		
Height		110,8 mm
Width		12,5 mm
Depth		75,3 mm

Where standards are undated, the 2017-05 latest editions shall apply.

9.1 Service life graphs

The service life graphs indicate the number of cycles from which failures due to wear must be expected. The wear is mainly caused by the electrical load; the mechanical load is negligible.

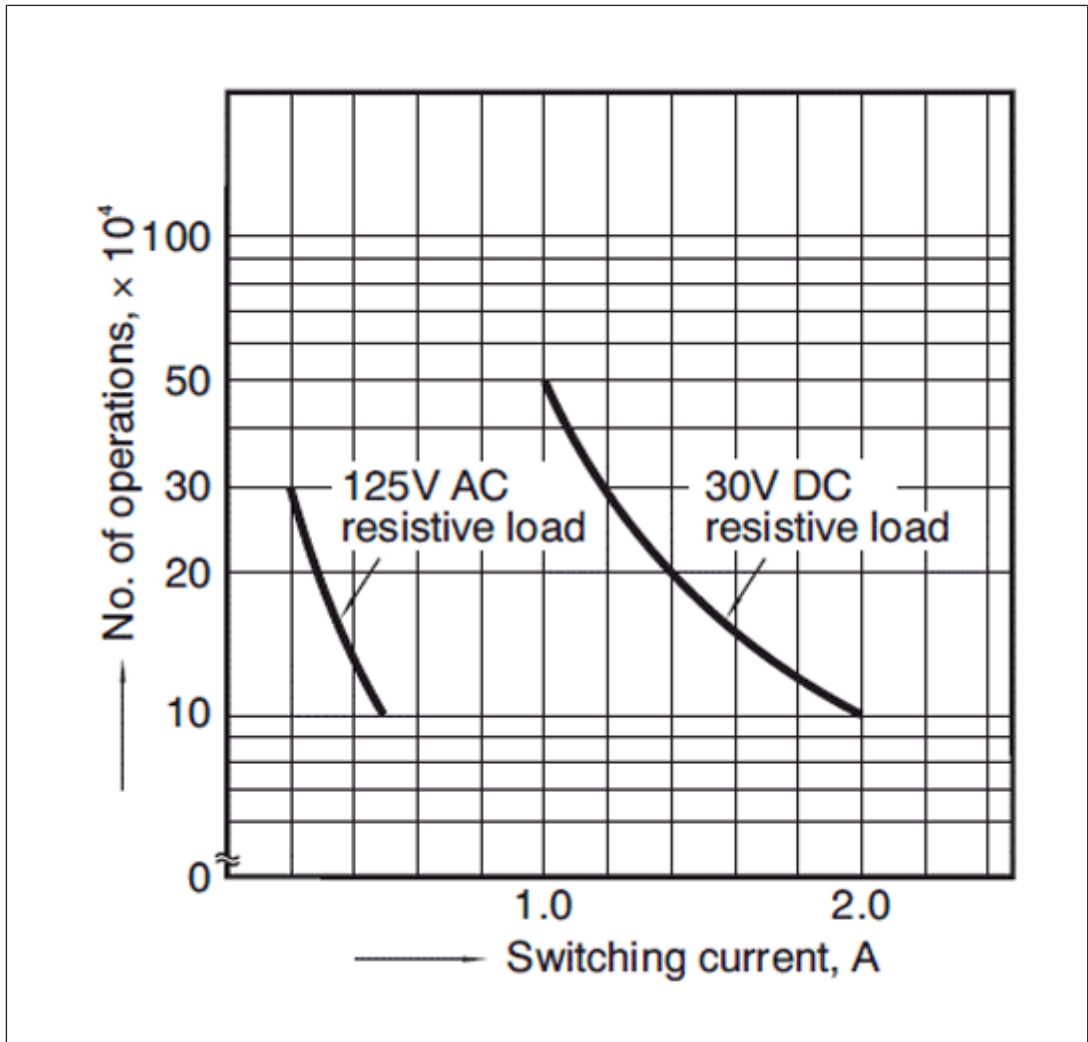

Fig.: Service life graph

We recommend you use semiconductor outputs to switch 24 VDC loads.

10 Order reference

10.1 Product

Product type	Features	Order no.
PSS u2 ES 4DO SR 0.5A	Electronic module	328421

10.2 Accessories

Terminal block

Product type	Features	Order no.
PSS u2 T 16 (1 pc.)	Terminal block 16-pin, scope of supply: 1 pieces	328850
PSS u2 T 16 (10 pcs.)	Terminal block 16-pin, scope of supply: 10 pieces	328851
PSS u2 T 16 (5 x 10 pcs.)	Terminal block 16-pin, scope of supply: 50 pieces	328852

Labelling bracket

Product type	Features	Order No.
PSS u2 A LC E1 (10 pcs.)	Labelling bracket for electronic module 23.5 x 10.5 mm, scope of delivery: 10 pieces	328910
PSS u2 A LC E2 (10 pcs.)	Labelling bracket for electronic module 103 x 10.5 mm, scope of delivery: 10 pieces	328911
PSS u2 A LA E1 (10 pcs.)	Labelling strips for electronic module 23.5 x 10.5 mm (10 x DIN A4 sheet)	328913
PSS u2 A LA E2 (10 pcs.)	Labelling strips for electronic module 103 x 10.5 mm (10 x DIN A4 sheet)	328914

Label holder for terminal block

Product type	Features	Order no.
PSS u2 A LC T3 (10 pcs.)	Label holder for terminal block 61 x 11.5 mm, scope of supply: 10 pieces	328912

Codierelemente

Produkttyp	Merkmale	Bestell-Nr.
PSS u2 A CE E (10 pc.)	Codierelemente für Elektronikmodule, 10 Stück	328860

Backplanes

Product type	Features	Order no.
PSS u2 B 1	Backplane, 1 slot	328811
PSS u2 B 4	Backplane, 4 slots	328810

► Support

Technical support is available from Pilz round the clock.

Americas

Brazil

+55 11 97569-2804

Canada

+1 888 315 7459

Mexico

+52 55 5572 1300

USA (toll-free)

+1 877-PILZUSA (745-9872)

Asia

China

+86 21 60880878-216

Japan

+81 45 471-2281

South Korea

+82 31 778 3300

Australia and Oceania

Australia

+61 3 95600621

New Zealand

+64 9 6345350

Europe

Austria

+43 1 7986263-0

Belgium, Luxembourg

+32 9 3217570

France

+33 3 88104003

Germany

+49 711 3409-444

Ireland

+353 21 4804983

Italy, Malta

+39 0362 1826711

Scandinavia

+45 74436332

Spain

+34 938497433

Switzerland

+41 62 88979-32

The Netherlands

+31 347 320477

Turkey

+90 216 5775552

United Kingdom

+44 1536 462203

You can reach our international hotline on:

+49 711 3409-222

support@pilz.com

Pilz develops environmentally-friendly products using ecological materials and energy-saving technologies. Offices and production facilities are ecologically designed, environmentally-aware and energy-saving. So Pilz offers sustainability, plus the security of using energy-efficient products and environmentally-friendly solutions.



We are represented internationally. Please refer to our homepage www.pilz.com for further details or contact our headquarters.

Headquarters: Pilz GmbH & Co. KG, Felix-Wankel-Straße 2, 73760 Ostfildern, Germany
Telephone: +49 711 3409-0, Telefax: +49 711 3409-133, E-Mail: info@pilz.com, Internet: www.pilz.com

PILZ
THE SPIRIT OF SAFETY

1004553-EN-03, 2022-01 Printed in Germany
© Pilz GmbH & Co. KG, 2019

CECE®, CHRE®, CMSE®, InduraNET p®, Leansafe®, Master of Safety®, Master of Security®, PAS4000®, PAScall®, PASconfig®, Pilz®, PTT®, PLID®, PMCPirimo®, PMCPiritego®, PMCTendo®, PMD®, PMJ®, PNOZ®, PRCM®, PRM®, PRMNET p®, PSEN®, PSENi®, PSS®, PVS®, SafetyBUS p®, SafetyEYE®, THE SPIRIT OF SAFETY® are registered and protected trademarks of Pilz GmbH & Co. KG in some countries. We would point out that product features may vary from the details stated in this document, depending on the status at the time of publication and the scope of the equipment. We accept no responsibility for the validity, accuracy and entirety of the text and graphics presented in this information. Please contact our Technical Support if you have any questions.