



PSS u2 ES 16PTD 24V

PILZ

THE SPIRIT OF SAFETY

- ▶ Control system PSS u2
- ▶ Remote I/O system PSS u2

This document is the original document.

Where unavoidable, for reasons of readability, the masculine form has been selected when formulating this document. We do assure you that all persons are regarded without discrimination and on an equal basis.

All rights to this documentation are reserved by Pilz GmbH & Co. KG. Copies may be made for the user's internal purposes. Suggestions and comments for improving this documentation will be gratefully received.

Pilz®, PIT®, PMI®, PNOZ®, Primo®, PSEN®, PSS®, PVIS®, SafetyBUS p®, SafetyEYE®, SafetyNET p®, the spirit of safety® are registered and protected trademarks of Pilz GmbH & Co. KG in some countries.



SD means Secure Digital

1	Introduction	4
1.1	Validity of documentation	4
1.2	Using the documentation	4
1.3	Definition of symbols	4
2	Overview	6
2.1	Module features	6
3	Safety	7
3.1	Intended use	7
3.2	System requirements	7
3.3	Safety regulations	7
3.3.1	Use of qualified personnel	7
3.3.2	Warranty and liability	8
3.3.3	Disposal	8
4	Function description	9
4.1	Block diagram	9
4.2	Supply	9
4.3	Voltage outputs	9
4.4	Energy-saving functions	10
5	Installation	11
5.1	General installation guidelines	11
5.1.1	Dimensions	11
5.2	Inserting and removing an electronic module	12
5.2.1	Inserting an electronic module	12
5.2.2	Removing an electronic module	14
5.2.3	Changing an electronic module during operation	15
6	Wiring	16
6.1	General wiring guidelines	16
6.1.1	Connection mechanism for terminal blocks	16
6.2	Terminal configuration	17
7	Operation	18
7.1	Display elements and messages	18
8	Technical details	20
9	Order reference	22
9.1	Product	22
9.2	Accessories	22

1 Introduction

1.1 Validity of documentation

This operating manual explains the function and operation, describes the installation and provides guidelines on how to connect the product.

This documentation is valid for the product PSS u2 ES 16PTD 24V hardware version 01 or higher. It is valid until new documentation is published.

1.2 Using the documentation

This document is intended for instruction. Only install and commission the product if you have read and understood this document. The document should be retained for future reference.

Please refer to the PSS u2 Installation Manual.

1.3 Definition of symbols

Information that is particularly important is identified as follows:



DANGER!

This warning must be heeded! It warns of a hazardous situation that poses an immediate threat of serious injury and death and indicates preventive measures that can be taken.



WARNING!

This warning must be heeded! It warns of a hazardous situation that could lead to serious injury and death and indicates preventive measures that can be taken.



CAUTION!

This refers to a hazard that can lead to a less serious or minor injury plus material damage, and also provides information on preventive measures that can be taken.



NOTICE

This describes a situation in which the product or devices could be damaged and also provides information on preventive measures that can be taken. It also highlights areas within the text that are of particular importance.



INFORMATION

This gives advice on applications and provides information on special features.

2 Overview

Module structure:

A module consists of

- ▶ an electronic module,
- ▶ a terminal block with cage clamp terminals and
- ▶ a module carrier

The electronic modules are plugged into the backplane and determine the function. The backplane is used for communication between the head module and the electronic modules and forms the carrier unit for the electronic modules. The terminal block is plugged into the electronic modules and is used to connect the field wiring.

Details of the terminal blocks that can be used are available under "Intended Use".

2.1 Module features

Application of the product PSS u2 ES 16PTD 24V:

Electronic module with 16 voltage outputs for standard applications.

The product has the following features:

- ▶ 16 Voltage outputs
- ▶ Current load capacity per output: 0,5 A
 - Short circuit-proof
 - Overload-proof
- ▶ Energy-saving functions
- ▶ The module provides advanced diagnostic data:
 - Overload
 - Short circuit
 - Undervoltage
- ▶ LEDs for:
 - Status of the 24 V voltage outputs
 - Module error
 - Operating status

3 Safety

3.1 Intended use

The module may be used for standard applications in a PSS u2 system.

Intended use includes making the electrical installation EMC-compliant. The module is designed for use in an industrial environment. Interference may occur if used in other areas.

The following is deemed improper use in particular

- ▶ Any component, technical or electrical modification to the module,
- ▶ Use of the module outside the areas described in this manual,
- ▶ Any use of the module that is not in accordance with the technical details.

Please also refer to [Installation manual PSS u2](#).

The module PSS u2 ES 16PTD 24V may be used in conjunction with the following terminal block:

- ▶ 16-pin terminal block

3.2 System requirements



INFORMATION

The module is supported by

- ▶ PASconfig from version 2.0.0
 - We recommend that you always use the latest version (download from www.pilz.com).

3.3 Safety regulations

3.3.1 Use of qualified personnel

The products may only be assembled, installed, programmed, commissioned, operated, maintained and decommissioned by persons who are competent to do so.

A competent person is a qualified and knowledgeable person who, because of their training, experience and current professional activity, has the specialist knowledge required. To be able to inspect, assess and operate devices, systems and machines, the person has to be informed of the state of the art and the applicable national, European and international laws, directives and standards.

It is the company's responsibility only to employ personnel who

- ▶ Are familiar with the basic regulations concerning health and safety / accident prevention,
- ▶ Have read and understood the information provided in the section entitled Safety
- ▶ Have a good knowledge of the generic and specialist standards applicable to the specific application.

3.3.2 Warranty and liability

All claims to warranty and liability will be rendered invalid if

- ▶ The product was used contrary to the purpose for which it is intended,
- ▶ Damage can be attributed to not having followed the guidelines in the manual,
- ▶ Operating personnel are not suitably qualified,
- ▶ Any type of modification has been made (e.g. exchanging components on the PCB boards, soldering work etc.).

3.3.3 Disposal

- ▶ When decommissioning, please comply with local regulations regarding the disposal of electronic devices (e.g. Electrical and Electronic Equipment Act).

4 Function description

4.1 Block diagram

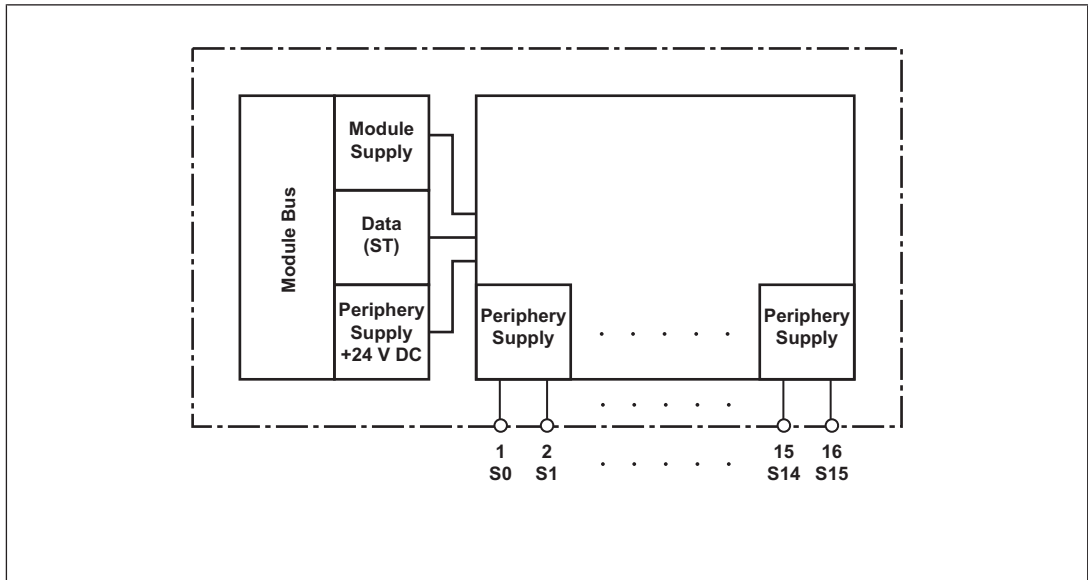

Fig.: Block diagram PSS u2 ES 16PTD 24V

4.2 Supply

- ▶ The module is supplied with voltage via the head module.
- ▶ The periphery supply provides the voltage outputs with voltage

When the supply voltage for the periphery supply is interrupted, the periphery supply is buffered for 20 ms. The buffering is designed for the input currents.

4.3 Voltage outputs

- ▶ The periphery supply is available at the voltage outputs.
- ▶ The voltage outputs supply the sensors at the inputs.
- ▶ The voltage outputs are protected against overload and short circuit.

4.4 Energy-saving functions

The energy-saving levels are controlled by the head module and are not configurable. The module supports the following energy-saving levels:

▶ Switching off the LEDs

The LEDs have two energy-saving levels:

- Switching off the LEDs to display the terminal status
- Switching off the LEDs to display the module and terminal status

▶ Switching off the terminals

- The module switches off the voltage at the voltage outputs.

▶ Standby mode

- All module functions are inactive.
- The LEDs for displaying the module and terminal status are switched off.

5 Installation

5.1 General installation guidelines



NOTICE

Damage due to electrostatic discharge!

Electrostatic discharge can damage components. Ensure against discharge before touching the product, e.g. by touching an earthed, conductive surface or by wearing an earthed armband.

5.1.1 Dimensions

The dimensions include the backplane, electronic module and terminal block.

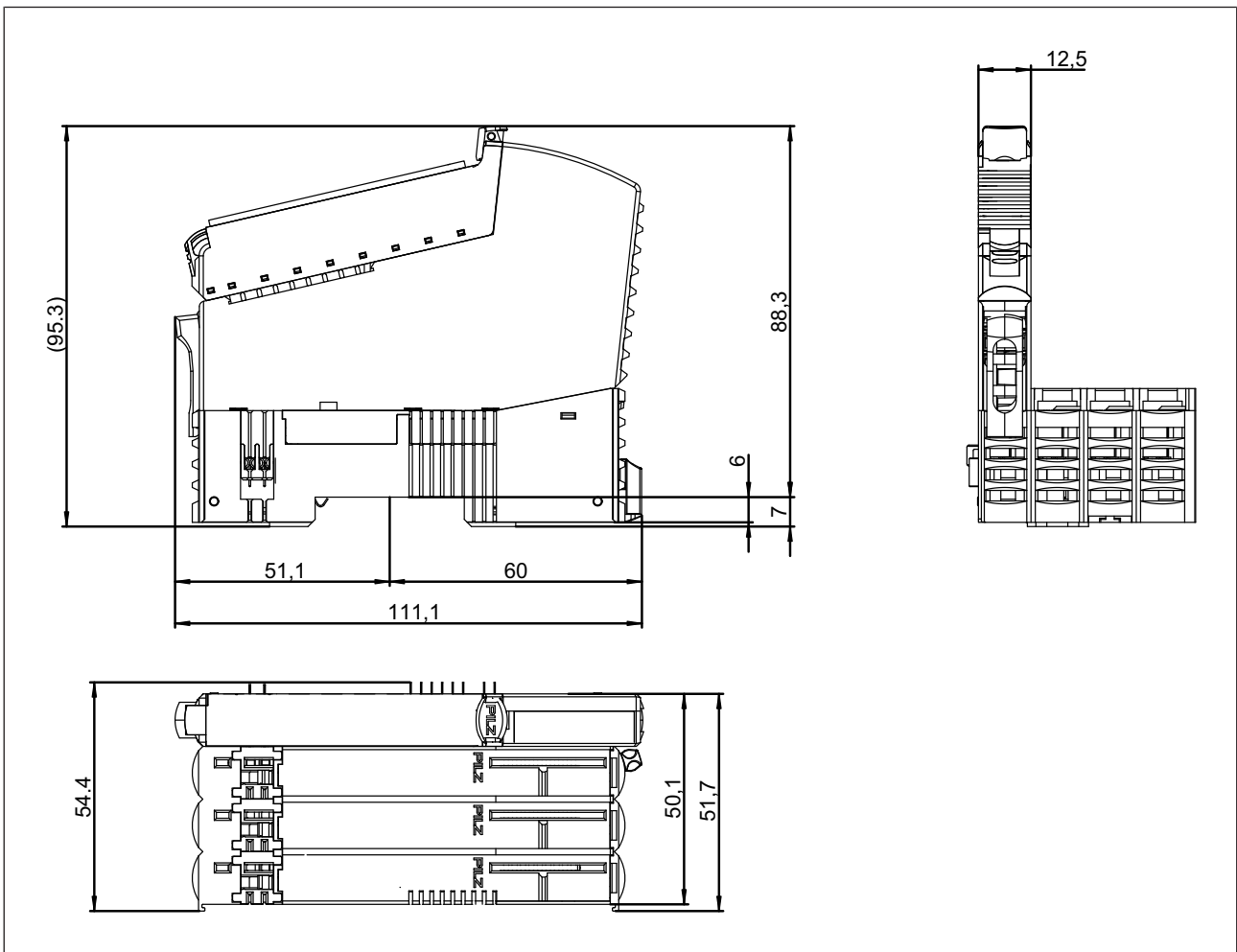

Fig.: Dimensions in mm, including backplane, electronic module and terminal block

5.2 Inserting and removing an electronic module

Please note:

- ▶ Backplane must be installed first.
- ▶ Electronic modules may only be plugged or unplugged if the terminal block has been removed first.
- ▶ The mechanics of the electronic modules are designed for 20 plug in/out cycles.

5.2.1 Inserting an electronic module

1. Insert the electronic module into the suspension lug on the backplane.

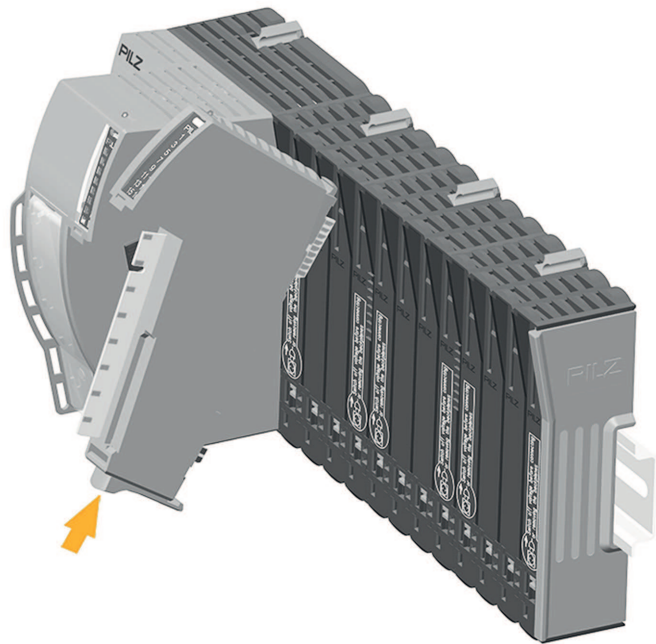

2. Swivel the electronic module downwards until you hear it click into place.

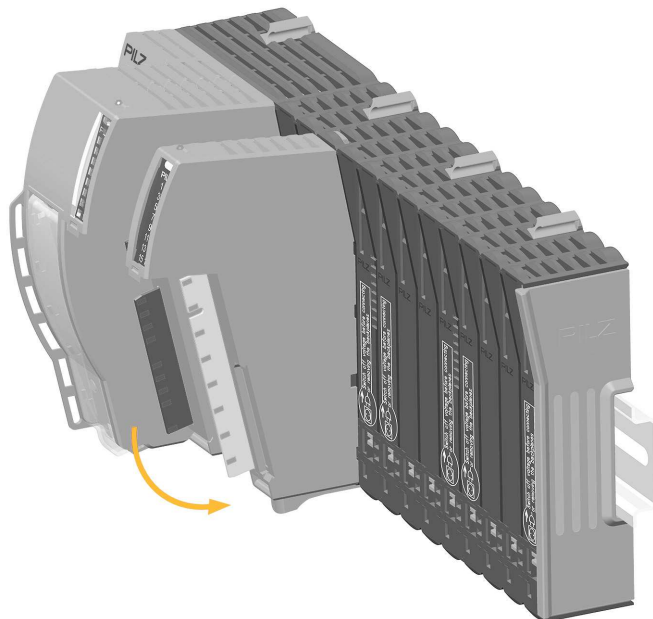

3. Insert the terminal block into the suspension lug on the module.

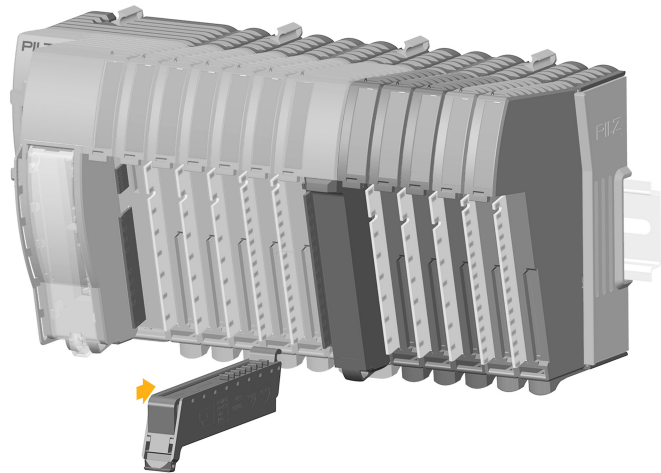

4. Swivel the terminal block upwards until you hear it click into place.

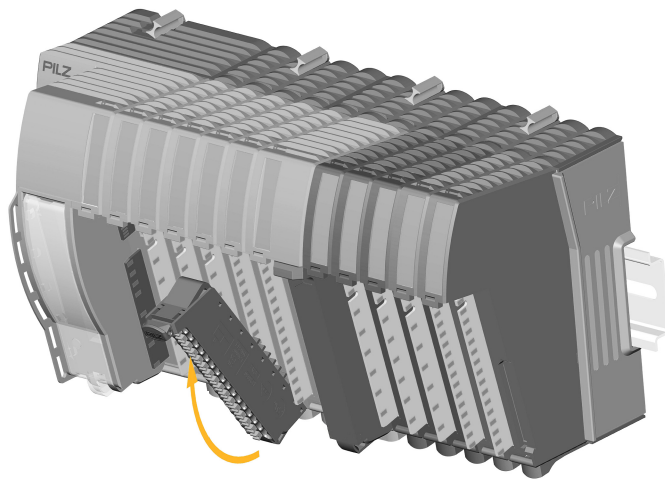

5.2.2 Removing an electronic module

1. Press the unlocking mechanism on the terminal block that is shown by the arrow and pull off the terminal block forward.

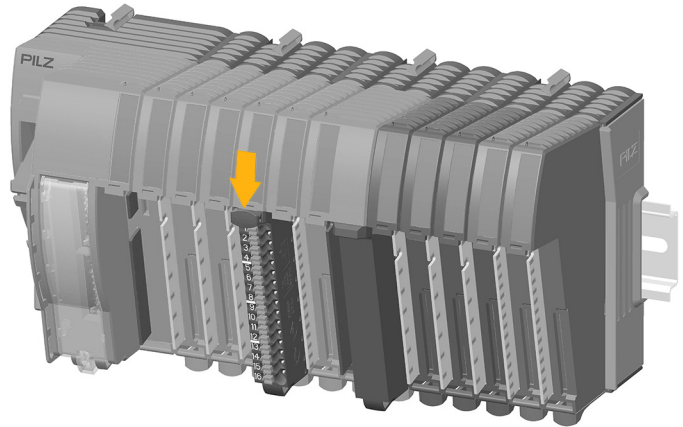

2. Press the unlocking mechanism that is shown by the arrow and pull off the electronic module upwards.

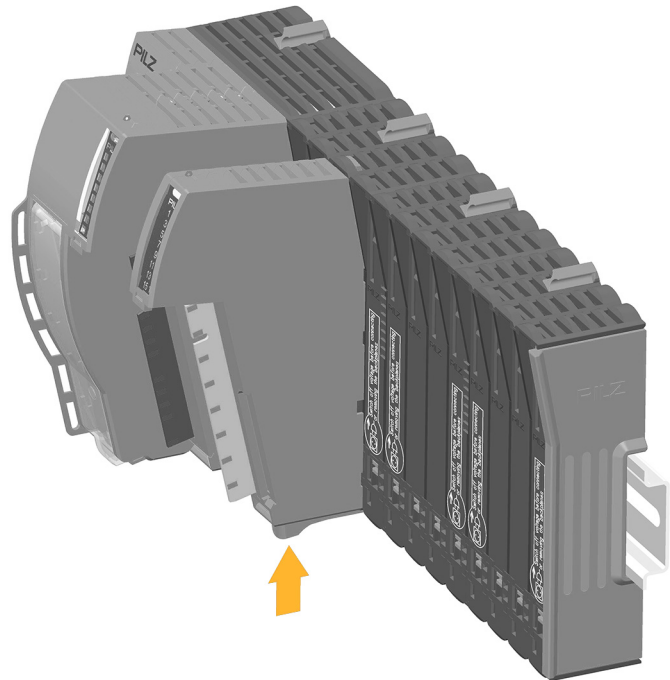



5.2.3 Changing an electronic module during operation

An electronic module can be hot swapped.

Effects:

- ▶ Module bus communication between the other modules is not interrupted.
- ▶ The configuration data is retained.
- ▶ The module is detected automatically as soon as the module is re-inserted.

Procedure:

1. [Removing an electronic module](#)  14]
2. [Inserting an electronic module](#)  12]

A new electronic module can be inserted during operation.

Procedure:

- ▶ [Inserting an electronic module](#)  12]

Effects:

- ▶ Module bus communication between the other modules is not interrupted.
- ▶ To detect the new module the following steps can be necessary:
 - Creating a new configuration or changing an existing configuration
 - Download of the configuration to the head module
 - Restart of the head module. After a restart, the system behaves as after a warm reset using a reset pushbutton (see operating manual of the head module, chapter "Reset pushbutton", section "Carrying out a warm reset (restart)").

6 Wiring

6.1 General wiring guidelines

Please note:

- ▶ Signal lines do not have to be shielded.

6.1.1 Connection mechanism for terminal blocks

Please note:

- ▶ The minimum cable cross section for field connection terminals on the terminal blocks is 0.15 mm^2 (AWG26).
- ▶ The maximum cable cross section for field connection terminals on the terminal blocks is 1.5 mm^2 with ferrules (AWG14)
- ▶ Use copper wiring.

Procedure:

- ▶ Use a flat head screwdriver.
- ▶ Strip the wire back 9 mm.
- ▶ Feed the stripped cable as far as it will go into the opening for the spring-loaded terminal.
- ▶ Check that the cable is firmly seated.

6.2 Terminal configuration

Example for connecting a single-channel actuator in 3-conductor wiring:

Terminal configuration		
PSS u2 ES 16DOD 1: Output O0 2: Output O1 3: Output O2 4: Output O3 5: Output O4 6: Output O5 7: Output O6 8: Output O7 9: Output O8 10: Output O9 11: Output O10 12: Output O11 13: Output O12 14: Output O13 15: Output O14 16: Output O15	ES 16PTD 24 V 1: Voltage output S0 2: Voltage output S1 3: Voltage output S2 4: Voltage output S3 5: Voltage output S4 6: Voltage output S5 7: Voltage output S6 8: Voltage output S7 9: Voltage output S8 10: Voltage output S9 11: Voltage output S10 12: Voltage output S11 13: Voltage output S12 14: Voltage output S13 15: Voltage output S14 16: Voltage output S15	ES 16PT 0 V 1: Periphery supply 0 V 2: Periphery supply 0 V 3: Periphery supply 0 V 4: Periphery supply 0 V 5: Periphery supply 0 V 6: Periphery supply 0 V 7: Periphery supply 0 V 8: Periphery supply 0 V 9: Periphery supply 0 V 10: Periphery supply 0 V 11: Periphery supply 0 V 12: Periphery supply 0 V 13: Periphery supply 0 V 14: Periphery supply 0 V 15: Periphery supply 0 V 16: Periphery supply 0 V
Actuators supplied via the 24 V and 0 V periphery supply:		
ES 16DOD 0.5 A ES 16PTD 24V ES 16PT 0V		

7 Operation

The status of the module is displayed via a red and a green LED. The status of the terminals is displayed via a green LED. If there is a module error, the module status display will light up red. The error will be signalled to the head module and will be entered in the head module's diagnostic log.

7.1 Display elements and messages

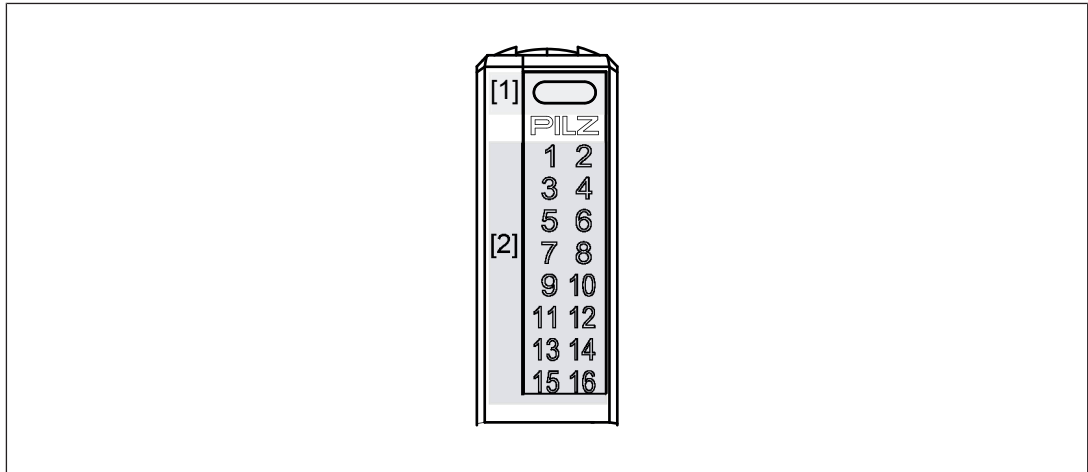



Legend

[1] Module status display





[2] Terminal status display

The module can detect the following module states:

[1]	Colour [1]	[2]	Colour [2]	Meaning	Further information
●	--	●		Module not ready for operation	
●	Green	●		Module ready for operation	
☉	Green	☉	Green	Module in operation and there is voltage at the 24 V terminal	
☉	Green	●	--	Module in operation but there is no voltage at the 24 V terminal	
⚡	Red	●	--	Configuration error Module was inserted in the wrong slot.	
☉	Red	●	--	Internal errors	See module's diagnostic log
●	Red	●	Green	The module status display and both terminal status displays on the relevant voltage output flash synchronously Short circuit/overload/undervoltage	See module's diagnostic log
●	Red	●	--	Temperature warning: Too warm (1)	See module's diagnostic log

[1]	Colour [1]	[2]	Colour [2]	Meaning	Further information
	Red		Green	The module status display and all terminal status displays flash synchronously Periphery supply is missing/temperature error: Too hot (1)	See module's diagnostic log

Legend

-  LED on
-  LED flashes
-  LED flashes briefly
-  LED off

(¹) There are two levels of overtemperature.

▶ Too warm:

If the module temperature exceeds a threshold value, then:

- a warning is sent to the head module.

If the temperature drops back below the threshold value, the module sends an all-clear.

▶ Too hot:

If the module temperature exceeds another threshold value, then:

- an error message is sent to the head module
- the voltage outputs are switched off

After the "too hot" message has been received, if the temperature drops back below the "too warm" threshold value, the module will switch to an error-free state.

8 Technical details

General	
Certifications	CE, UKCA, cULus Listed
Application range	Standard
Module's device code	0005h
Number of ST status bits	16
Electrical data	
Internal supply voltage (module supply)	
Module's power consumption	0,28 W
Periphery's supply voltage (periphery supply)	
Module's power consumption with no load	0,53 W
Max. power consumption of a voltage output	0,055 W
Max. power dissipation of module	1,7 W
Permitted loads	inductive, capacitive, resistive
Voltage outputs	
Number of outputs for periphery supply	16
Rated voltage	24 V DC
Max. output current at rated voltage	0,5 A
Short circuit-proof	yes
Potential isolation	yes
Typ. threshold value for overload	1,4 A
Environmental data	
Climatic suitability	EN 60068-2-1, EN 60068-2-14, EN 60068-2-2, EN 60068-2-30, EN 60068-2-78
Ambient temperature	
In accordance with the standard	EN 60068-2-14
Temperature range	0 - 60 °C
Storage temperature	
In accordance with the standard	EN 60068-2-1/-2
Temperature range	-40 - 70 °C
Climatic suitability	
In accordance with the standard	EN 60068-2-78
Humidity	93 % r. h. at 40 °C
Condensation during operation	Not permitted
Max. operating height above sea level	2000 m
EMC	EN 61131-2 (Zone B)
Vibration	
In accordance with the standard	EN 60068-2-6
Frequency	8,4 - 150 Hz
Acceleration	10 m/s²
Shock stress	
In accordance with the standard	EN 60068-2-27
Acceleration	150 m/s²
Duration	11 ms

Environmental data

Airgap creepage	
In accordance with the standard	EN 60664-1
Overvoltage category	III
In accordance with the standard	EN 61131-2
Overvoltage category	II
Pollution degree	2

Protection type	
In accordance with the standard	EN 60529
Housing	IP20
Mounting area (e.g. control cabinet)	IP54

Potential isolation

Potential isolation between	Periphery supply and module supply
Type of potential isolation	Functional insulation
Rated surge voltage	2500 V

Mechanical data

Material	
Housing	PC
Mounting type	plug-in
Dimensions	
Height	110,8 mm
Width	12,5 mm
Depth	72,5 mm
Weight	39 g

Where standards are undated, the 2017-05 latest editions shall apply.

9 Order reference

9.1 Product

Bezeichnung	Merkmale	Bestell.-Nr.
PSS u2 ES 16PTD 24V	Elektronikmodul	328085

9.2 Accessories

Terminal block

Product type	Features	Order no.
PSS u2 T 16 (1 pc.)	Terminal block 16-pin, scope of supply: 1 pieces	328850
PSS u2 T 16 (10 pcs.)	Terminal block 16-pin, scope of supply: 10 pieces	328851
PSS u2 T 16 (5 x 10 pcs.)	Terminal block 16-pin, scope of supply: 50 pieces	328852

Labelling bracket

Product type	Features	Order No.
PSS u2 A LC E1 (10 pcs.)	Labelling bracket for electronic module 23.5 x 10.5 mm, scope of delivery: 10 pieces	328910
PSS u2 A LC E2 (10 pcs.)	Labelling bracket for electronic module 103 x 10.5 mm, scope of delivery: 10 pieces	328911
PSS u2 A LA E1 (10 pcs.)	Labelling strips for electronic module 23.5 x 10.5 mm (10 x DIN A4 sheet)	328913
PSS u2 A LA E2 (10 pcs.)	Labelling strips for electronic module 103 x 10.5 mm (10 x DIN A4 sheet)	328914

Label holder for terminal block

Product type	Features	Order no.
PSS u2 A LC T3 (10 pcs.)	Label holder for terminal block 61 x 11.5 mm, scope of supply: 10 pieces	328912

Codierelemente

Produkttyp	Merkmale	Bestell.-Nr.
PSS u2 A CE E (10 pc.)	Codierelemente für Elektronikmodule, 10 Stück	328860

Backplanes

Product type	Features	Order no.
PSS u2 B 1	Backplane, 1 slot	328811
PSS u2 B 4	Backplane, 4 slots	328810

