



pilz

Programmable Safety Systems PSS-Range

PSS SB Router1
Operating Manual
Item No. 20 223



The spirit of safety.

All rights to this manual are reserved by Pilz GmbH. Copies may be made for internal purposes.

While every effort has been made to ensure that the information in this manual is accurate, no responsibility can be accepted for errors or omissions contained within it.

We reserve the right to amend specifications without notice. We are grateful for any feedback on the contents of this manual.

The names of products, goods and technologies used in this manual are trademarks of the respective companies.

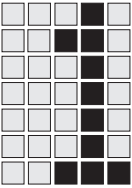
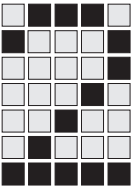
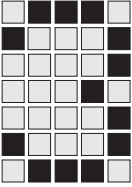
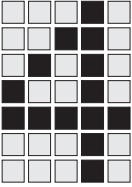
	Introduction	1-1
	Validity of documentation	1-1
	Overview of manual	1-2
	Definition of symbols	1-3
	Overview	2-1
	Range	2-1
	Safety	3-1
	Intended use	3-1
	PSS CPU versions	3-1
	Programming device versions	3-1
	EMC	3-2
	ESD	3-2
	Warranty and liability	3-2
	Disposal	3-2
	Safety guidelines	3-2
	Function Description	4-1
	Transmission rate	4-2
	Function	4-2
	Telegram filtering	4-4
	Priority-driven telegram processing	4-4

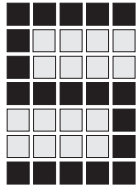
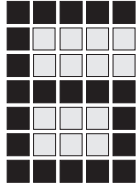
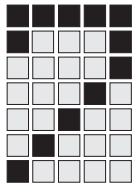
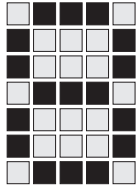
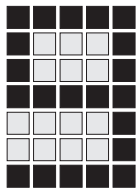
	<h2>Configuration</h2>	<p>5-1</p>
	<h3>Rules for incorporating the Router</h3>	<p>5-1</p>
	<h3>Incorporating the Management Device</h3>	<p>5-2</p>
	<h3>Reducing the total cable runs</h3>	<p>5-3</p>
	<h3>Increasing the max. permitted overall length</h3>	<p>5-4</p>
	<h2>Installation</h2>	<p>6-1</p>
	<h2>Commissioning and Operation</h2>	<p>7-1</p>
	<h3>Commissioning</h3>	<p>7-1</p>
	<h4>Programming device “PSS SW PG”</h4>	<p>7-1</p>
	<h4>Special configuration features</h4>	<p>7-1</p>
	<h4>Adapting the monitoring times</h4>	<p>7-2</p>
	<h4>Adapting the times for timeout</h4>	<p>7-2</p>
	<h4>Adapting the Router correction time</h4>	<p>7-3</p>
	<h4>Commissioning procedure</h4>	<p>7-4</p>
	<h3>Operation</h3>	<p>7-5</p>
	<h4>Display elements</h4>	<p>7-5</p>
	<h4>Fault diagnostics and rectification</h4>	<p>7-6</p>
	<h2>Technical Details</h2>	<p>8-1</p>
	<h2>Appendix</h2>	<p>9-1</p>

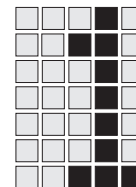

Introduction

This manual describes the hardware and usage of the “PSS SB Router1”. The Router is used in SafetyBUS p systems.

To fully understand this manual you will need to be conversant with the information found in the general documentation for the SafetyBUS p PSS-range. In particular you should read the SafetyBUS p System Description and SafetyBUS p Installation Manual.

This manual is intended for instruction and should be retained for future reference.

Validity of documentation

This documentation is valid for the PSS SB Router1 from Version 2.0. It is valid until new documentation is published. The latest documentation is always enclosed with the unit.

Introduction

Overview of manual

This manual is divided into the following chapters:

1 Introduction

The introduction is designed to familiarise you with the contents, structure and specific order of this manual.

2 Overview

This chapter provides a brief overview of the module's most important features and its application range.

3 Safety

This chapter **must be read** as it contains important information on safety and intended use.

4 Function Description

The function description contains detailed information on how the module operates.

5 Configuration

This chapter describes the special features which need to be considered when configuring a SafetyBUS p system using a Router.

6 Installation

This chapter describes how to install the module.

7 Commissioning and Operation

This chapter describes the different requirements and options when commissioning and operating the module.

8 Technical Details

9 Appendix

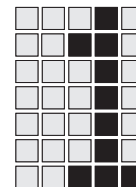

Definition of symbols

Information in this manual that is of particular importance can be identified as follows:



DANGER!

This warning must be heeded! It warns of a **hazardous situation which poses an immediate threat of serious injury and death**, and indicates preventive measures that can be taken.



WARNING!

This warning must be heeded! It warns of a **hazardous situation that could lead to serious injury and death** and indicates preventive measures that can be taken.



CAUTION!

This refers to a hazard that can lead to a less serious or minor injury plus material damage, and also provides information on preventive measures that can be taken.



NOTICE

This describes a situation in which the unit(s) could be damaged and also provides information on preventive measures that can be taken.



INFORMATION

This gives advice on applications and provides information on special features, as well as highlighting areas within the text that are of particular importance.

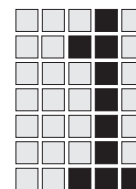

Introduction

Notes

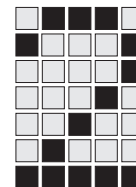

Overview

The “PSS SB Router1” is a Router designed for use in SafetyBUS p systems.

It is suitable for the logical division of the SafetyBUS p architecture into bus segments. These bus segments can then operate at different transmission rates. Transmission rates must be adapted to the respective cable runs in the corresponding bus segment.

Using one or more Routers in a SafetyBUS p system does **not** increase the maximum permitted number of bus subscribers.

The Router is **not** a safety-related device.

Range

The hardware package consists of:

- One Router
PSS SB Router1
- One operating manual
PSS SB Router1

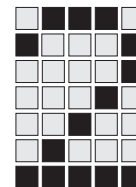

Overview

Notes

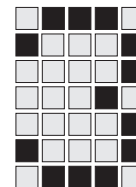

Safety

Intended use

The “PSS SB Router1” is designed for use in SafetyBUS p systems.

Specific data for the Router is given in the chapter entitled “Technical Details”. Use outside the specifications given here will be deemed as improper use.

Any component, technical or electrical modifications to the Router will be deemed as improper use.

Use of the Router outside the areas described in this manual will be deemed as improper use.

Following the information in this manual contributes to intended use.

The “PSS SB Router1” is **not** a safety-related device.

PSS CPU versions

Please note that, on the PSS-range of programmable safety systems listed below, the Router is only supported from the CPU versions stated:

- Modular programmable safety systems from the PSS-range:
 - PSS SB CPU from Version 1.5 onwards
 - PSS1 SB CPU from Version 1.5 onwards

- Compact programmable safety systems from the PSS-range:
 - PSS SB 3006 DP-S from Version 1.0 onwards
 - PSS SB 3006 IBS-S from Version 1.3 onwards
 - PSS SB 3056 from Version 1.3 onwards

Programming device versions

Please note that use of the Router in a SafetyBUS p architecture is only supported by the PSS SW PG system software from Version 4.2 onwards.

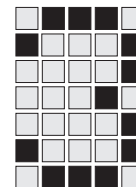

Safety

EMC

The device is designed for use in an industrial environment. Interference may occur if used within a domestic environment.

ESD



CAUTION!

Electrostatic discharge can damage components on the device. Ensure against discharge before touching the device, e.g. by touching an earthed, conductive surface or by wearing an earthed armband.

Warranty and liability

All claims to warranty and liability will be rendered invalid if:

- The module was used contrary to the purpose for which it was intended
- Damage can be attributed to not having followed the guidelines in the manual
- Operating personnel are not suitably trained or sufficiently qualified
- The housing was opened
- Any type of modification has been made (e.g. exchanging components on the PCB boards, soldering work etc.).

Disposal

The module must be disposed of properly when it reaches the end of its service life

Safety guidelines

Information and requirements stated in the “SafetyBUS p Installation Manual” and “PSS SB Router1 Installation Manual” are also valid for use with the Router (see System Manual for the “SafetyBUS p-range”). Failure to keep to these guidelines and safety requirements will render all warranty, guarantee and liability claims invalid.

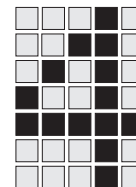

Function Description

As the safety on the “SafetyBUS p” safe bus system is guaranteed by safe telegram transfer, the Router is not a safety-related device. It has a single-channel structure.

The Router does not have a device address. It is not counted as one of the actual SafetyBUS p subscribers, and accordingly, the Router is not registered as a bus subscriber.

Several Routers may be used in a SafetyBUS p system. Using Routers on SafetyBUS p does not affect the max. permitted number of “real” bus subscribers with a device address.

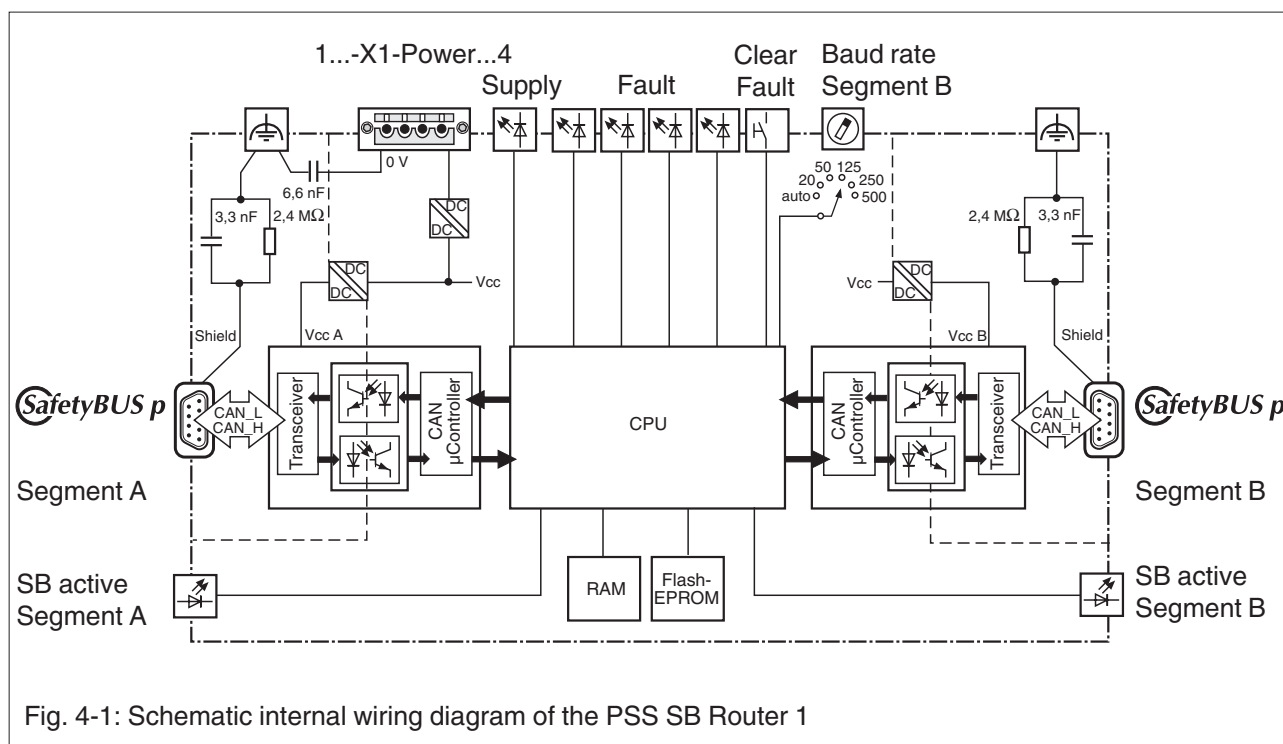

Function Description

Transmission rate

The Router divides a SafetyBUS p architecture into two logical bus segments, A and B. The Router manages the transmission rate for each bus segment separately. This means that the two bus segments can have different transmission rates.

There is only one option for bus segment A: the Router automatically synchronises with the available transmission rate. The Router automatically sets itself to the transmission rate already set for the bus segment.

For segment B, the transmission rate can be selected using the rotary switch “Baudrate Segment B” (see Fig. 4-2). This rotary switch is only responsible for the transmission rate in bus segment B. If it is set to “auto”, the Router will copy the transmission rate from bus segment A. Setting it to any other valid position enables you to select that transmission rate. The switch settings are labelled accordingly.

Function

If it is connected correctly, the Router will start to operate as soon as supply voltage (“X1-Power”) is applied (see Fig. 4-2). The “Supply” LED indicates whether supply voltage is present.

After an initialisation phase, the Router will synchronise with the transmission rate from bus segment A. In bus segment B it will operate at the set transmission rate.

The LEDs “SB active Segment A” and “SB active Segment B” indicate whether there is telegram traffic in the corresponding bus segment.

The Router has 4 LEDs (“Fault”) for fault diagnostics. The last error to be detected is displayed in coded form via the “Fault” LEDs (see Fig. 4-2). A detected error will automatically trigger a software reset in the Router. The fault indicator can be cleared via the “Clear Fault” button (see Fig. 4-2). The “Clear Fault” button is only used to reset the fault indicator, i.e. you **cannot** reset the Router using this button.

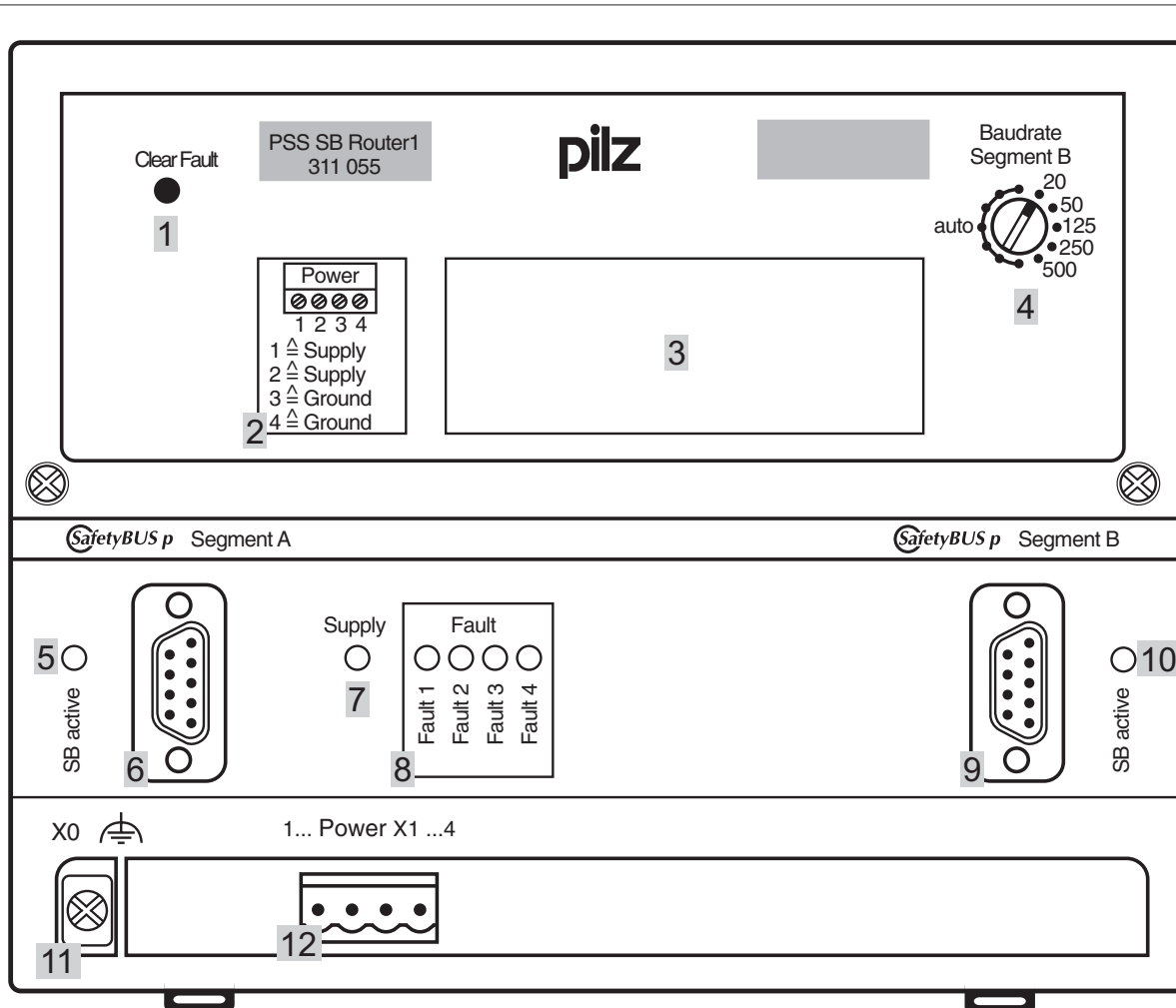
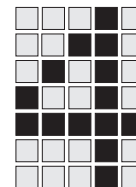

- 1: Reset button for resetting the “Fault” LEDs
- 2: Labelling strip for the supply voltage
- 3: Labelling strip for the coded error messages from the “Fault” LEDs
- 4: Rotary switch for setting the transmission rate in bus segment B
- 5: LED indicator for the operating status of bus segment A
- 6: SafetyBus p interface: bus segment A
- 7: LED indicator for the operating status of the supply voltage
- 8: LED indicators for fault diagnostics
- 9: SafetyBus p interface: bus segment B
- 10: LED indicator for the operating status of bus segment B
- 11: Connection terminal for the functional earth
- 12: Terminal strip for the supply voltage

Fig. 4-2: Operator and display elements on the PSS SB Router1

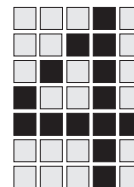

Function Description

Telegram filtering

The Router is transparent for telegrams that are required in both bus segments. However, it filters in both directions any telegrams that are only required in one of the two bus segments.

With an appropriate bus architecture, this filter mechanism can reduce the bus load and lead to shorter reaction times.

The Router will also detect automatically if a new Device has been connected to SafetyBUS p or if a Device has been removed.

Priority-driven telegram processing

The Router passes on incoming telegrams to the other bus segment in order of priority. Telegrams with high priority will be given preference. Telegrams with lower priority will be stored in the telegram buffer.

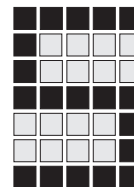

Configuration

Rules for incorporating the Router

Using the Router will bring extensive benefits, especially if relevant features are taken into consideration when planning the bus architecture. For this reason you should always note the following points:

- If possible, plan to use the Router in places where there is relatively little telegram traffic between bus segments A and B. For example, this may be the case with physically remote I/Os which are seldom addressed (E-STOP buttons etc.).
- If possible, only incorporate complete I/O-Groups in the bus segments (Master LD, I/O-Devices). This will reduce the amount of telegram traffic between the bus segments.
- A telegram buffer is available for the temporary storage of telegrams transferring between bus segments A and B. Poor bus architecture may cause the telegram buffer to overflow.



INFORMATION

The following configuration should be avoided:

A large amount of telegram traffic occurs between the two segments while at the same time there is a considerable difference in the transmission rates of the bus segments (e.g. 500 kbit/s in bus segment A and 20 Kbit/s in bus segment B).

Configuration

Incorporating the Management Device

If the Router is operating at the same transmission rate in both bus segments, the Management Device may be located in either bus segment A or B. In this case, set the rotary switch to “auto”.

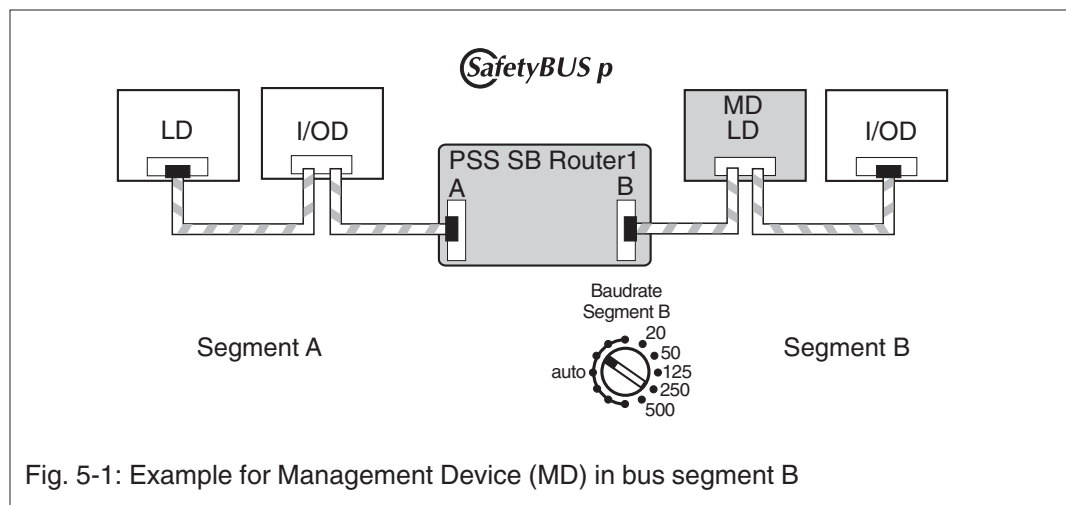

If the Router is to operate at a fixed transmission rate in bus segment B, the Management Device **must** be located in bus segment A. In this case, use the rotary switch to set a transmission rate for bus segment B (rotary switch set at “20” ... “500”).

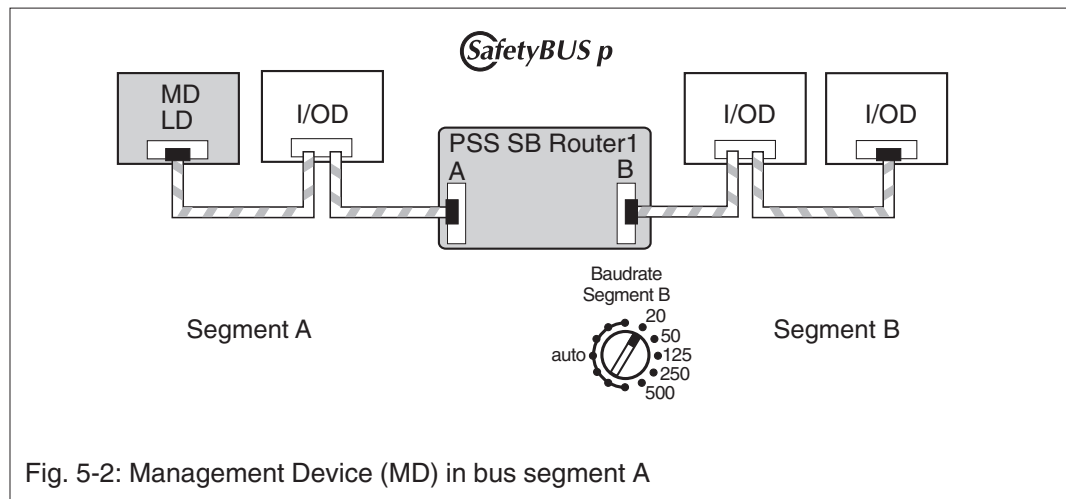

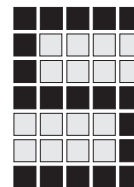

Reducing the total cable runs

Total cable runs can be reduced if the connection to physically remote bus subscribers is made via sub branches. The Router is used as a Y-connector. This way you will not need to use a return line.

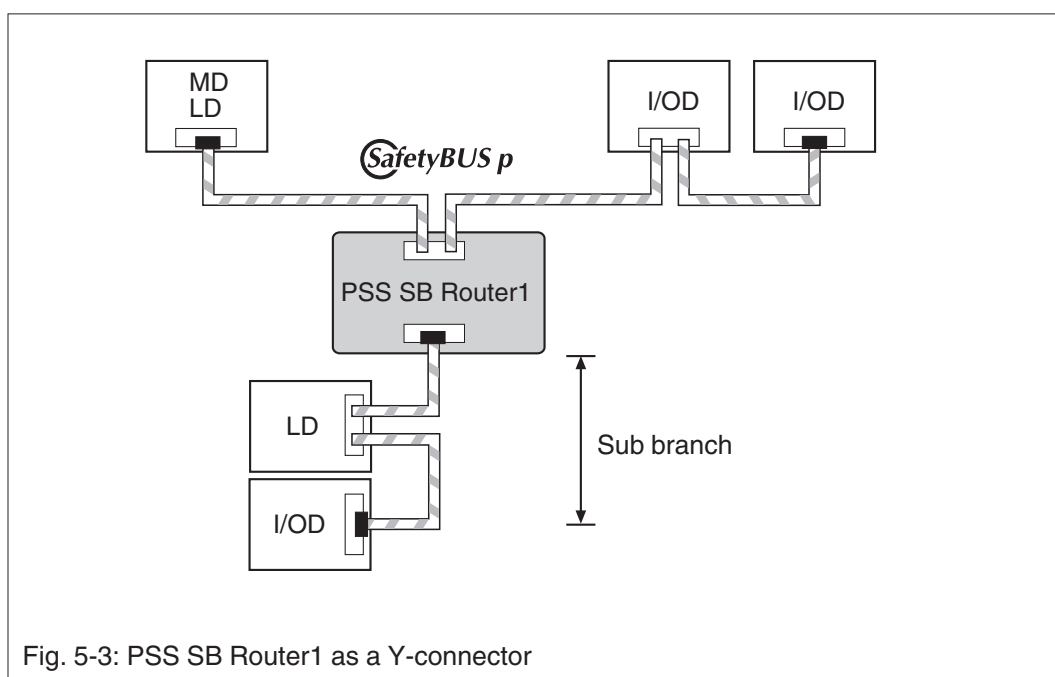

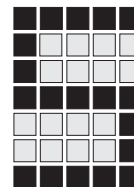

Configuration

Increasing the max. permitted overall length

The maximum total cable run on a SafetyBUS p system is limited by the selected transmission rate (see also the SafetyBUS p Installation Manual). In such cases Routers can be used to increase the overall length of SafetyBUS p.



INFORMATION

Using Routers divides SafetyBUS p into logical bus segments. The rules regarding the interdependence of transmission rate and cable runs are valid within the bus segments. However, longer cable runs can be achieved by connecting Routers in series.

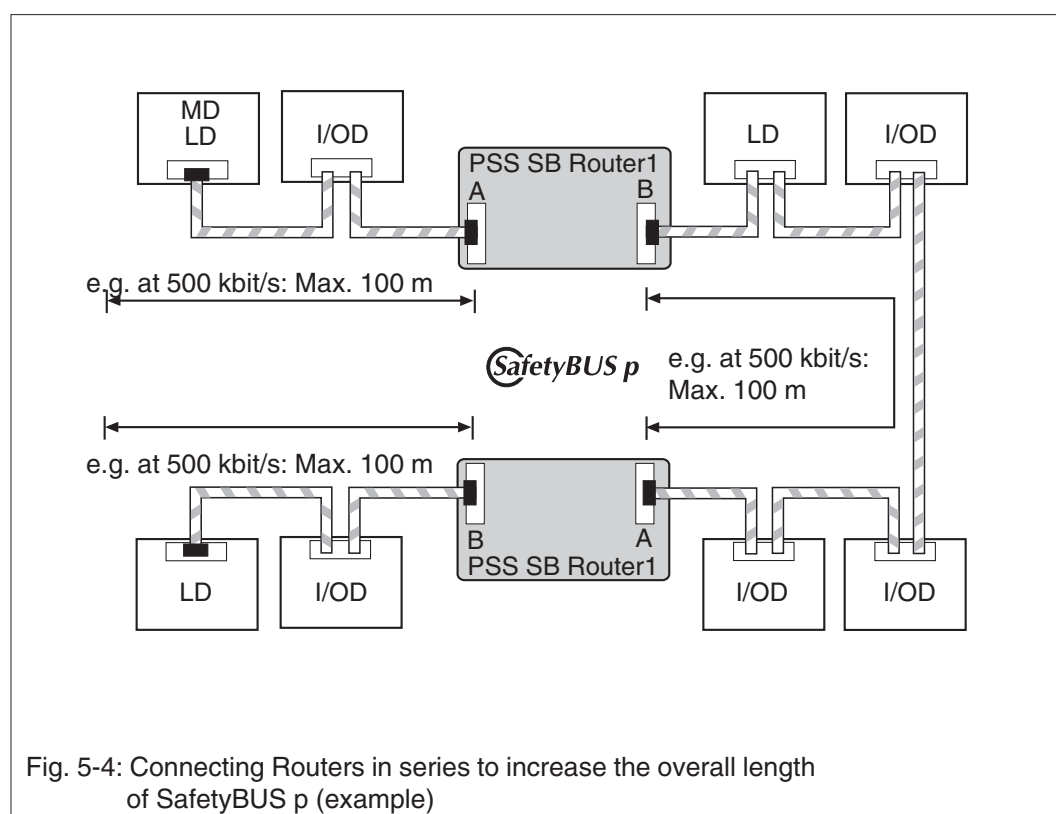

Installation

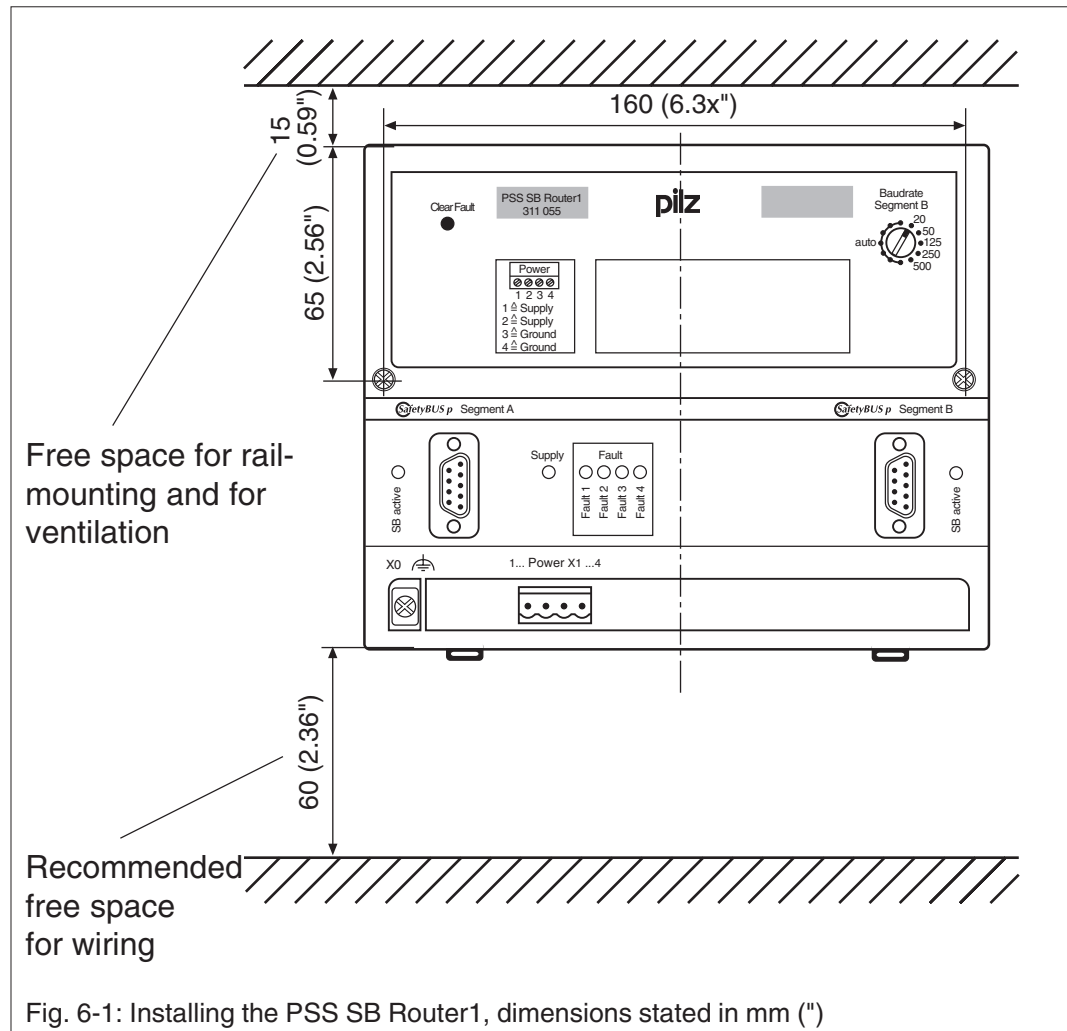
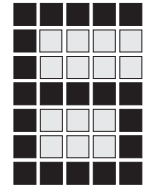

Dimensions in mm ("):

H x W x D 140 x 170 x 52 (5.51 x 6.69 x 2.05)

The module can be attached to a 35 mm DIN-rail (top hat rail) or can be screwed on to a mounting plate using fixing bolts (order no. 311 068).

To affix the module on to a mounting plate, drill 2 x M4 holes (internal thread) in the mounting plate, as shown in the above diagram (tolerance: ± 0.2 mm/0.01").

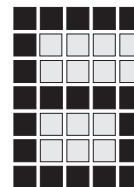

Installation



INFORMATION

When installing the Router please refer also to the following manuals:

- SafetyBUS p Installation Manual
(part of the System Manual “PSS-Range SafetyBUS p”)
- PSS SB Router1 Installation Manual
(part of the System Manual “PSS-Range SafetyBUS p” and supplied with every SafetyBUS p-compatible PSS)

In particular you should take note of the information regarding EMC-compliance.

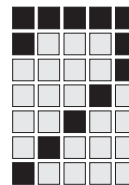

Commissioning and Operation

Commissioning

Programming device “PSS SW PG”

The procedure for configuring SafetyBUS p is described in the operating manual for the “Programming Device PSS SW PG”. The information given in this section refers only to the special features involved in the configuration of the “PSS SB Router1”.



NOTICE

The “PSS SB Router1” is only supported from Version 4.2 of the programming device onwards.

Special configuration features

The Router is not a SafetyBUS p subscriber in the true sense of the word. For this reason you do not configure a Device Address or allocate an I/O-Group and LD etc. in the programming device.

However, the Router's various processing times do affect the times that are available to the MD for monitoring telegram traffic. In specific terms these are the MD monitoring times listed below:

- Event Timeout
- Byte Timeout (not yet available)
- Domain Timeout
- Cycle Timeout
- Router Correction Time

Monitoring times are pre-set in the configurator for use when configuring the MD (for default values see Fig. 7-1). The pre-set values are normally sufficient, so that no additional parameters need to be set. However, monitoring times may need to be adjusted in the following cases:

- Where a large number of Routers are connected in series on SafetyBUS p.
- Where the Router is operated at a different transmission rate in the two segments. Such a case mainly occurs when the fastest transmission rate is set in segment A and the slowest in segment B.

Commissioning and Operation

```
Management Device
Device address      : 43
Bus participant    : PSS SB 3000/3100
Event Timeout in ms : 50
Byte Timeout in ms : 256
Domain Timeout in ms : 250
Cycle Timeout in ms : 110
Transm. rate in kBaud : 3
Router correction time in ms : 0
List of Logic Devices : 43
List of groups      : 5.M,13.M
```

Fig. 7-1: Default settings for monitoring times (“Management Device” dialogue box in the programming device “PSS SW PG”)

Adjusting the monitoring times

Monitoring times must be adjusted if certain error messages occur during operation. Error entries are obtained by reading the FS error stack on a PSS on SafetyBUS p (CPU-Display/programming device). The “Error List” description in the “PSS-Range” manual contains an overview of the error messages, including advice on how to rectify the error.

Adjusting the times for Timeout

You can adjust the Timeout times (Event Timeout, Domain Timeout and Cycle Timeout) as follows:

- Establish the Timeout that has caused the error (CPU-Display on PSS, FS error stack on PSS, error list).
- Establish the correction time for the Timeout using the table overleaf. Establish the correction time for each Router connected in series on SafetyBUS p.



INFORMATION

If a Router is being operated at different transmission rates in segments A and B, the correction time will be geared towards the slowest Router transmission rate.

- Add the established correction time of each Router to the corresponding Timeout (see Fig. 7-1).

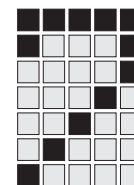

Table for establishing a Timeout's correction value (Event Timeout, Domain Timeout or Cycle Timeout):

	20 kBit/s	50 kBit/s	125 kBit/s	250 kBit/s	500 kBit/s
Correction value for Timeout (per Router)	25 ms	10 ms	5 ms	3 ms	2 ms

Sample error messages:

Time adjustment	Error message
Event Timeout	Timeout on Event
	Event was not confirmed in time
Domain Timeout	MD detects Timeout on group start with Device
	LD detects Timeout on group start with Device
	Timeout on Domain through Device
	Timeout on Domain Request on Domain through Device
	Domain Timeout
	LD missing on connection test
Cycle Timeout	I/OD missing on connection test

Commissioning and Operation

Adjusting the Router correction time

The Router correction time must be adjusted if certain error messages occur during operation.

Procedure:

- Determine the Router correction time from the table below.
If there are several Routers connected in series, use Segment A of the Router containing the MD and Segment B of the Router with the slowest transmission rate.
- Enter the established Router correction time in the configurator (see Fig. 7-1).
- If the error continues to occur, increase the Router correction time.



INFORMATION

The Router correction time has direct influence on the time for the connection test via the MD (Cycle Timeout). The longer the Router correction time you select, the more the frequency with which the MD sends the Cycle Strobe signal for the connection test will increase. This will then increase the bus load.

Table for establishing the Router correction time:

Segment A (Segment with the MD)	Segment B (set via rotary switch)				
	20 kBit/s	50 kBit/s	125 kBit/s	250 kBit/s	500 kBit/s
20 kBit/s	x	x	x	x	x
50 kBit/s	5 ms	x	x	x	x
125 kBit/s	10 ms	5 ms	x	x	x
250 kBit/s	15 ms	10 ms	5 ms	x	x
500 kBit/s	20 ms	15 ms	10 ms	5 ms	x

Sample error messages:

Time adjustment	Error message
Router correction time	SafetyBUS p traffic interrupted
	MD not available

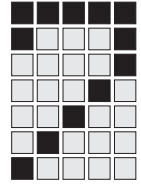

Commissioning procedure

Follow the instructions below:

- Install the Router.
Please follow the instructions given in the “SafetyBUS p Installation Manual” and “PSS SB Router1 Installation Manual”.



INFORMATION

If the module is attached to an earthed DIN-rail, this will automatically cover the module's functional earth requirements.

- Connect the Router to the SafetyBUS p segments.
- Set the transmission rate for bus segment B on the Router.
- Connect the supply voltage.
After an initial phase the Router will reach operating status.
- Use the two “SB active” LEDs to check that the Router connection for bus segments A and B has been correctly established (see section entitled “Operation”, under “Fault diagnostics and rectification”).



INFORMATION

- I/O-Groups may need to be restarted.
- Monitoring times may need to be adjusted.

You can obtain more precise information by reading the FS error stack from any PSS on SafetyBUS p. This process is described in the operating manual for the “Programming Device PSS SW PG”.

Commissioning and Operation

Operation

Display elements

A number of display elements can be used to check that the Router is operating correctly.

LED "Supply"

This LED indicates that the supply is present, in which case the LED will be green.

LED "SB active Segment A"

This LED indicates that bus segment A on the Router is connected to the MD. If it is connected correctly, the LED will be green and telegram traffic will occur.

LED "SB active Segment B"

This LED indicates that bus segment B on the Router is connected to the MD. If it is connected correctly, the LED will be green and telegram traffic will occur.

LEDs "Fault 1" ... "Fault 4"

The fault LEDs indicate the last errors that the Router detected. The error messages are coded (see section entitled "Fault diagnostics and rectification").

Operator element

Rotary switch "Baudrate Segment B"



INFORMATION

Please note that adjusting the transmission rate while the Router is in operation will lead to an error (see section entitled "Operation", under "Fault diagnostics and rectification").

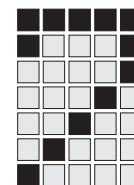

Fault diagnostics and error rectification

- LED off
- LED lit

Fault 1	Fault 2	Fault 3	Fault 4	Key
○	○	○	○	→ No fault
●	○	○	○	→ Bus segment A: Telegram buffer overflow Effects: - Data telegrams lost - Affected I/O-Groups stopped - Automatic software reset on Router Remedy: - May need to optimise the bus architecture - Reset display using “Clear Fault” button - Start the affected I/O-Groups
○	●	○	○	→ Bus segment B: Telegram buffer overflow Effects: - Data telegrams lost - Affected I/O-Groups stopped - Automatic software reset on Router Remedy: - May need to optimise the bus architecture - Reset display using “Clear Fault” button - Start the affected I/O-Groups
●	●	○	○	→ The transmission rate for bus segment B of the Router was adjusted during operation. Effects: - Affected I/O-Groups stopped - Automatic software reset on Router - Router operating at a new transmission rate Remedy: - Check the transmission rate setting - May need to adjust the transmission rate of all devices in bus segment B - Reset display using “Clear Fault” button - Start the affected I/O-Groups

(Continued overleaf)

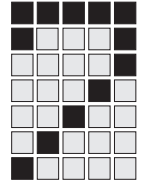

Commissioning and Operation

(Continued)

Fault 1	Fault 2	Fault 3	Fault 4	Key
○	○	☀	○	<p>→ Internal error</p> <p>Effects:</p> <ul style="list-style-type: none"> - Affected I/O-Groups stopped - Automatic software reset on Router <p>Remedy:</p> <ul style="list-style-type: none"> - May need to change Router - Start the affected I/O-Groups
☀	○	☀	○	<p>→ No connection to MD.</p> <p>Reason:</p> <p>The MD is in bus segment B, although a fixed transmission rate (20 ... 500 kBit/s) has been set for bus segment B of the Router (see “PSS SB Router1 Installation Manual”).</p> <p>Effects:</p> <ul style="list-style-type: none"> - No bus operation possible - Automatic software reset on Router <p>Remedy:</p> <ul style="list-style-type: none"> - Set transmission rate for bus segment B of the Router to “auto” or - Install MD in bus segment A

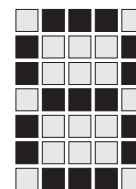

Technical Details

Electrical data	
Supply voltage	24 VDC
Tolerance	20 ... 30 VDC including residual ripple (max. $\pm 1.2V$)
Power consumption	80 mA plus load currents required for fibre optic connections (25 mA per fibre optic connection)
Galvanic isolation	Yes (optocoupler), between two SafetyBUS p [®] segments
SafetyBUS p[®]	
Transmission rate	Max. 500 kBit/s (can be set separately for bus segment B)
Cable runs	Max. 3500 m (per bus segment)
Transmission type	Two-wire differential (3-core cable)
Connection	Two 9-pin D-Sub connectors (female)
Status indicator	LEDs for power, bus status and diagnostics
Subscribers	Max. 64 (whole bus system)
Environmental data	
Protection type (EN 60529, 10/91)	IP 20
Protection class (DIN VDE 0106, Part1/A1, 04/90)	3
Mounting position	Any
Ambient temperature (DIN IEC 68-2-14, 06/87)	0 ... +60 °C
Storage temperature (EN 60068-2-1/-2, 03/93)	-25 ... +70 °C
Climatic suitability (IEC 68-2-30, 09/86)	max. 95 % r.h.
Condensation	Not permitted
Vibration (EN 60068-2-6, 04/95)	Frequency range: 10 ... 100 Hz Amplitude: 0.1 mm, max. 5g
Vibration resistance (DIN IEC 68-2-29)	30g, 11 ms/10g, 16 ms
EMC	EN 50.082-2, 03/95 EN 55.011 A, 08/96
Mechanical data	
Weight	460 g
Dimensions (H x W x D)	140 x 170 x 52 mm

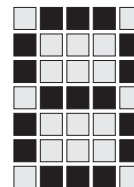

Technical Details

Notes

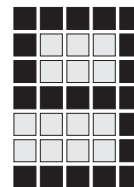

Appendix

Changes in the documentation

Changes from version I to version II

Old p. no.	New p. no.	Change
---	1-1	new: Section "Validity of the documentation"
---	8-1	new: residual ripple value new: Power consumption per fibre optic connection

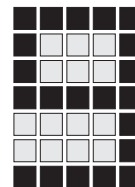

Appendix

Notes

A

Pilz Ges.m.b.H.
Modcenterstraße 14
1030 Wien
Austria
Telephone: 01 7986263-0
Telefax: 01 7986264
E-Mail: pilz@pilz.at

AUS

Pilz Australia
Industrial Automation LP.
9/475 Blackburn Road
Mt. Waverley, Melbourne VIC 3149
Australia
Telephone: 03 95446300
Telefax: 03 95446311
E-Mail: safety@pilz.com.au

B L

Pilz Belgium
Bijenstraat 4
9051 Gent (Sint-Denijs-Westrem)
Belgium
Telephone: 09 3217570
Telefax: 09 3217571
E-Mail: info@pilz.be

BR

Pilz do Brasil Sistemas Eletrônicos
Industriais Ltda.
Rua Ártico, 123 - Jd. do Mar
09726-300
São Bernardo do Campo - SP
Brazil
Telephone: 11 4337-1241
Telefax: 11 4337-1242
E-Mail: pilz@pilzbr.com.br

CH

Pilz Industrieelektronik GmbH
Gewerbepark Hintermättli
Postfach 6
5506 Mägenwil
Switzerland
Telephone: 062 88979-30
Telefax: 062 88979-40
E-Mail: pilz@pilz.ch

D

Pilz GmbH & Co.
Felix-Wankel-Straße 2
73760 Ostfildern
Germany
Telephone: 0711 3409-0
Telefax: 0711 3409-133
E-Mail: pilz.gmbh@pilz.de

DK

Pilz Skandinavien K/S
Ellegaardvej 25 L
6400 Sønderborg
Denmark
Telephone: 74436332
Telefax: 74436342
E-Mail: pilz@pilz.dk

E

Pilz Industrieelektronik S.L.
Camí Ral, 130
Polígono Industrial Palou Nord
08400 Granollers
Spain
Telephone: 938497433
Telefax: 938497544
E-Mail: central@pilzspain.com

F

Pilz France Electronic
1, rue Jacob Mayer
BP 12
67037 Strasbourg Cedex
France
Telephone: 03 88104000
Telefax: 03 88108000
E-Mail: siege@pilz-france.fr

FIN

Pilz Skandinavien K/S
Pakilantie 61
00660 Helsinki
Finland
Telephone: 09 27093700
Telefax: 09 27093709
E-Mail: pilz.sk@kolumbus.fi

GB

Pilz Automation Technology
Willow House, Medicott Close
Oakley Hay Business Park
Corby
Northants NN18 9NF
United Kingdom
Telephone: 01536 460766
Telefax: 01536 460866
E-Mail: sales@pilz.co.uk

I

Pilz Italia Srl
Via Meda 2/A
22060 Novedrate (CO)
Italy
Telephone: 031 789511
Telefax: 031 789555
E-Mail: info@pilz.it

IRL

Pilz Ireland Industrial Automation
Cork Business and Technology Park
Model Farm Road
Cork
Ireland
Telephone: 021 4346535
Telefax: 021 4804994
E-Mail: sales@pilz.ie

J

Pilz Japan Co., Ltd.
Three One Building 701
3-20-5 Shin-Yokohama
Kohoku-ku
Yokohama 222-0033
Japan
Telephone: 045 471-2281
Telefax: 045 471-2283
E-Mail: pilz@pilz.co.jp

MEX

Pilz de Mexico, S. de R.L. de C.V.
Circuito Pintores # 170
Cd. Satellite
C.P. 53100
Naucalpan de Juarez, Edo. de Mexico
Mexico
Telephone: 55 5572 1300
Telefax: 55 5572 4194
E-Mail: info@mx.pilz.com

NL

Pilz Nederland
Postbus 186
4130 ED Vianen
Netherlands
Telephone: 0347 320477
Telefax: 0347 320485
E-Mail: info@pilz.nl

P

Pilz Industrieelektronik S.L.
R. Eng Duarte Pacheco, 120
4 Andar Sala 21
4470-174 Maia
Portugal
Telephone: 229407594
Telefax: 229407595
E-Mail: pc.portugal@mail.telepac.pt

PRC

Pilz China Representative Office
Rm. 302
No. 88 Chang Shu Road
Shanghai 200040
China
Telephone: 021 62493031
Telefax: 021 62493036
E-Mail: sales@pilz.com.cn

ROK

Pilz Korea Liaison Office
402 Samsung Midas Officetel
775-1, Janghang-Dong,
Ilsan-Gu, Koyang-Si
Kyungki-Do 411-837
Korea
Telephone: 031 8159541
Telefax: 031 8159542
E-Mail: EJSK@chollian.net

SE

Pilz Skandinavien K/S
Energigatan 10 B
43437 Kungsbacka
Sweden
Telephone: 0300 13990
Telefax: 0300 30740
E-Mail: pilz@tripnet.se

SGP

Pilz Industrial Automation Pte Ltd.
No. 61 Kaki Bukit Ave 1
#05-01 Shun Li Industrial Park
Singapore 417943
Singapore
Telephone: 84444440
Telefax: 84444441
E-Mail: sales@pilz.com.sg

TR

Pilz Elektronik Güvenlik Ürünleri
ve Hizmetleri Tic. Ltd. Şti.
Tan İş Merkezi
Kükürtlü Caddesi No: 67
C-Blok Daire: 1
16080 Bursa
Turkey
Telephone: 0224 2360180
Telefax: 0224 2360184
E-Mail: pilz.tr@pilz.de

USA

Pilz Automation Safety L.P.
7150 Commerce Boulevard
Canton
Michigan 48187
USA
Telephone: 734 354-0272
Telefax: 734 354-3355
E-Mail: info@pilzusa.com

WWW

www.pilz.com

...

In many countries we are represented by sales partners.

Please refer to our Homepage for further details or contact our headquarters.



Pilz GmbH & Co.
Felix-Wankel-Straße 2
73760 Ostfildern, Germany
Telephone: +49 711 3409-0
Telefax: +49 711 3409-133
E-Mail: pilz.gmbh@pilz.de

pilz
more than automation