

EC-Type Examination Certificate

No. M6A 020132 0248 Rev. 02

Holder of Certificate:	Pilz GmbH & Co. KG Felix-Wankel-Str. 2 73760 Ostfildern GERMANY
Product:	Automation Equipment, Safety Related Safety-related automation device
Model(s):	Automation systems PSS 4000 and PSS universal (PSSu)
Parameters:	Power Supply: 24VDC Protection Class: IP20 (IP67)

The report and the user documentation in the current valid revision are mandatory part of this certificate. The product complies with the below listed safety requirements only if the specifications documented in the currently valid revision of this report are met. The certified components are listed in the report PO86101T: Safety related modules according to the currently valid revision.

This EC Type Examination Certificate is issued according to Article 12(3) b or 12(4) a of Council Directive 2006/42/EC relating to machinery. It confirms that the listed Annex-IV equipment complies with the principal protection requirements of the directive. It refers only to the sample submitted to TÜV SÜD Product Service GmbH for testing and certification. For details see: www.tuvsud.com/ps-cert

Test report no.: PO86167C

Valid until: 2028-11-05

Date, 2023-11-08



(Christian Dirmeier)

Page 1 of 1

TÜV SÜD Product Service GmbH is Notified Body according to Council Directive 2006/42/EC relating to machinery, notified by publication in the Official Journal of the EC with identification No.0123.

TÜV SÜD Product Service GmbH • Certification Body • Ridlerstraße 65 • 80339 Munich • Germany



Product Service

CERTIFICATE

No. Z10 020132 0247 Rev. 02

Holder of Certificate: **Pilz GmbH & Co. KG**
Felix-Wankel-Str. 2
73760 Ostfildern
GERMANY

Certification Mark:



Product: **Automation Equipment, Safety Related**
Safety-related automation device

Model(s): **Automation systems**
PSS 4000 and PSS universal (PSSu)

Parameters: Power Supply: 24VDC
Protection Class: IP20 (IP67)

The report and the user documentation in the current valid revision are mandatory part of this certificate. The product complies with the below listed safety requirements only if the specifications documented in the currently valid revision of this report are met. The certified components are listed in the report PO86101T: Safety related modules according to the currently valid revision.

Tested according to: EN IEC 62061:2021
EN ISO 13849-1:2015 (up to Cat 4, PL e)
EN 61508-1:2010 (SIL1-3)
EN 61508-2:2010 (SIL1-3)
EN 61508-3:2010 (SIL1-3)
EN 61511-1:2017/A1:2017
EN 60204-1:2018
EN 61131-2:2007

The product was tested on a voluntary basis and complies with the essential requirements. The certification mark shown above can be affixed on the product. It is not permitted to alter the certification mark in any way. In addition the certification holder must not transfer the certificate to third parties. This certificate is valid until the listed date, unless it is cancelled earlier. All applicable requirements of the testing and certification regulations of TÜV SÜD Group have to be complied. For details see: www.tuvsud.com/ps-cert

Test report no.: PO86167C
Valid until: 2028-11-05

Date, 2023-11-08

(Christian Dirmeier)



Liste zur Verfolgung der Versionsfreigaben der sicherheitsgerichteten Baugruppen des Automatisierungssystems:

List for tracking the version releases of safety related modules
of the automation system:

PSSu / PSS 4000

Hersteller / Manufacturer:

Pilz GmbH & Co. KG
Felix-Wankel-Straße 2
D-73760 Ostfildern

Bericht-Nr. / Report No.: **PO86101T**

Revision: **3.8**

Datum / Date: **2025-12-12**

Dieser Bericht ist zugehörig zu den Zertifikaten / This report is related to the certificates

M6A 020132 0248 Rev. 02

Z10 020132 0247 Rev. 02

Testing Laboratory for Safety Components:

TÜV SÜD Rail GmbH - Rail Automation
Westendstr. 199
D-80686 Munich

Certification Body:

TÜV SÜD Product Service GmbH
Ridlerstr. 65
D-80339 Munich



Rail

Inhalt / content:

1 PAS (Pilz Automation Suite) 3

 1.1 PAS 4000 3

 1.2 PASconnect 4

2 PSS 4000 5

 2.1 PSS 4000 – Firmware / PSS 4000 – Firmware 5

 2.2 PSS 4000 - Kopfmodule / PSS 4000 - Head modules 6

 2.3 PSS4000 - Kopfmodule IP67 / PSS4000 - Head modules IP67 8

 2.4 PSS 4000 - Aktive Elektronikmodule / PSS 4000 - Active electronic moduls 9

 2.5 PSS 4000 - Elektronikmodule / PSS 4000 - Electronic modules 11

 2.6 PSS 4000 - Spannungsversorgungs-Modul / PSS 4000 - Powersupply modules 12

 2.7 PSS 4000 - Fail-Safe-Funktionsbausteine / PSS 4000 - Failsafe function blocks 12

3 PSSu 18

 3.1 PSSu - Kopfmodule / PSSu - Head module 18

 3.2 PSSu - Spannungsversorgungs-Modul / PSSu - Powersupply modules 18

4 PSS4000 + PSSu - Elektronikmodule / PSS4000 + PSSu - Electronic modules 19

5 Koppel-Module / Coupling modules 20

6 Zubehör / Accessories 20

Änderung / Changes:

Kapitel / Chapter	Baugruppe / Device	Modifications
2.7	FS_SafeEthernetConnection 2	Neuer PSS 4000 - Fail-Safe-Funktionsbaustein / New PSS 4000 - Failsafe function block



Rail

1 PAS (Pilz Automation Suite)

1.1 PAS 4000

PAS 4000 dient der Programmierung von Steuerungen der Systemfamilie PSS 4000 und des SafetyNET p. Die Verwendung der Softwarebausteine aus den PSS 4000 Software-Paketen wird von **PAS 4000** unterstützt.

PAS 4000 erfüllt die Anforderungen an ein als T3, T2 und T1 klassifiziertes Offline-Support-Tool gemäß EN 61508-3:2010. Darüber hinaus erfüllt **PAS 4000** die Anforderungen an ein Parametrierungstool gemäß EN ISO 13849-1:2015 Abschnitt 4.6.4 und EN IEC 62061:2021 Abschnitt 6.7. Die integrierten Bibliothekselemente erfüllen die Anforderungen der EN 61508-3:2010 hinsichtlich der Systematikfähigkeit von SC3 und können in Anwendungssoftware bis SIL 3 verwendet werden.

Die Einschränkungen der Programmierumgebung **PAS 4000** und der eingeschränkte, definierte Befehlssatz, führen dazu, dass der Sprachumfang für die Applikationserstellung als LVL (Limited Variability Language) gemäß EN 61508-4:2010, EN ISO 13849-1:2015 und EN IEC 62061:2021 eingestuft werden kann.

Die Anforderungen gelten als erfüllt, falls **PAS 4000** mit dem Automatisierungssystem und gemäß Sicherheitshandbuch eingesetzt wird.

PAS 4000 is used to program control systems of the PSS 4000 system family and SafetyNET p. The use of the software blocks from the PSS 4000 software packages is supported by **PAS 4000**.

PAS 4000 meets the requirements of an offline support tool classified as T3, T2 and T1 according to EN 61508-3:2010. In addition, **PAS 4000** meets the requirements for a parameterization tool according to EN ISO 13849-1:2015 Section 4.6.4 and EN IEC 62061:2021 Section 6.7. The integrated library elements meet the requirements of EN 61508-3:2010 regarding the systematic capability of SC3 and can be used in application software up to SIL 3. The limitations of the **PAS 4000** programming environment and the limited, defined command set mean that the language scope for application creation can be classified as LVL (Limited Variability Language) according to EN 61508-4:2010, EN ISO 13849-1:2015 and EN IEC 62061:2021.

The requirements are considered to be met if **PAS 4000** is used with the automation system and in accordance with the safety manual.

Typ / Type ¹⁾ (Sach-Nr. / Order No.)	Version	Interner Prüfbericht Internal Test Report	Bemerkung Remark
PAS 4000	1.11.x	PO82828T R2.3	--
	1.12.x	PO82828T R2.4	--
	1.13.x	PO82828T R2.5	--
	1.14.x	PO82828T R2.6	--
	1.15.x	PO82828T R2.8.1	--
	1.16.x	PO82828T R2.9	--
	1.17.x	PO82828T R2.10	--
	1.18.x	PO82828T R2.11	--
	1.19.x	PO82828T R2.12	--
	1.20.x	PO82828T R2.13	--
	1.21.x	PO82828T R2.14	--
	1.22.x	PO82828T R2.16	--



Rail

Typ / Type ¹⁾ (Sach-Nr. / Order No.)	Version	Interner Prüfbericht Internal Test Report	Bemerkung Remark
	1.23.x	PO82828T R2.17	--
	1.24.x	PO82828T R2.18	<u>Einschränkung der Sicherheitsfunktion</u> Bei PAS-Version 1.24.0 bis 1.27.1 wird es in folgenden seltenen Fällen zur Einschränkung der Sicherheitsfunktion kommen: Bei Einsatz von IL, Ladder oder wenn bei Multi Programmierung die Datentypen FIXED oder LFIXED bei Vergleichsoperationen mit unterschiedlichen Datentypen verwendet werden. Daher sind PAS-Versionen 1.24.0 bis 1.27.1 nur dann verwendbar, wenn die zuvor benannte Bedingung nicht zutrifft. <u>Restriction of the safety function</u> In PAS versions 1.24.0 to 1.27.1 , the safety function will be restricted in the following rare cases: When using IL, ladder, or multi-level programming and the FIXED or LFIXED data types are used in comparison operations with different data types. Therefore, PAS versions 1.24.0 to 1.27.1 can only be used if the previously mentioned condition does not apply.
	1.25.x	PO100913T R1.0	
	1.26.x	PO102048T R1.0	
	1.27.x	PO103462T R1.0	
	1.28.x	PO104846T R1.0	
	1.29.x	PO105926T R1.0	

1.2 PASconnect

PASconnect dient der Erstellung von Kommunikationsverbindungen zwischen verschiedenen PSS 4000 Einheiten via SafetyNet p. Die Kommunikationsverbindungen werden offline erstellt und über PAS 4000 in die PSS 4000 Einheiten geladen.

PASconnect is used to create communication connections between different PSS 4000 units via SafetyNET p. The communication connections are created offline and loaded into PSS 4000 units via PAS 4000.

Typ / Type ¹⁾ (Sach-Nr. / Order No.)	Version	Interner Prüfbericht Internal Test Report	Bemerkung Remark
PASconnect	1.0.x	PO90060T R1.0	--
	1.1.x	PO90060T R1.1	--
	1.2.x	PO90060T R1.2	--
	1.3.x	PO90060T R1.3	--
	1.4.x	PO90060T R2.0	--



Rail

2 PSS 4000

2.1 PSS 4000 – Firmware / PSS 4000 – Firmware

Version	Interner Prüfbericht Test Report	Bemerkung Remark
1.0.x	PO82828T R1.0	<u>Einschränkung der Sicherheitsfunktion</u> Bei PSSu-Kopfmodulen mit einer Firmware-Version kleiner 1.6.0 könnte es in folgenden seltenen Fällen zur Einschränkung der Sicherheitsfunktion kommen: <ul style="list-style-type: none"> • An einem Kopfmodul mit einer Firmware-Version kleiner 1.6.0 wurden keine FS-Ein- und FS-Ausgangsmodule eingesetzt. • An einem Kopfmodul mit einer Firmware-Version kleiner 1.6.0 waren FS-Ein- und FS-Ausgangsmodule vorhanden, aber weder das PSSu-Kopfmodul selbst noch ein anderes PSSu-Kopfmodul im Projekt hat sowohl lesend auf die FS-Eingänge als auch schreibend auf die FS-Ausgänge zugegriffen. Falls die oben genannten Applikationsbedingungen zutreffen, muss Version 1.6.0 oder höher eingesetzt werden.
1.1.x	PO82828T R1.2	
1.2.x	PO82828T R1.3	
1.3.x	PO82828T R1.4	
1.4.x	PO82828T R1.5	
1.5.x	PO82828T R1.6	<u>Restriction of the safety function</u> On PSSu head modules with a firmware version below 1.6.0, the safety function may be restricted in the following rare cases: <ul style="list-style-type: none"> • On a head module with a firmware version below 1.6.0, no FS input modules and no FS output modules were used. • On a head module with a firmware version below 1.6.0, FS input modules and FS output modules were present, but neither the PSSu head module itself nor any other PSSu head module within the project both read the FS inputs and wrote to the FS outputs. If the application conditions above are met, version 1.6.0 or higher shall be used.
1.6.x	PO82828T R1.8	--
1.7.x	PO82828T R1.9	--
1.8.x	PO82828T R2.0	--
1.9.x	PO82828T R2.1	--
1.10.x	PO82828T R2.2	--
1.11.x	PO82828T R2.3	--
1.12.x	PO82828T R2.4	--
1.13.x	PO82828T R2.5	--
1.14.x	PO82828T R2.6	--
1.15.x	PO82828T R2.8.1	--
1.16.x	PO82828T R2.9	--
1.17.x	PO82828T R2.10	--
1.18.x	PO82828T R2.11	--
1.19.x	PO82828T R2.12	--
1.20.x	PO82828T R2.13	--
1.21.x	PO82828T R2.14	--



Rail

Version	Interner Prüfbericht Test Report	Bemerkung Remark
1.22.x	PO82828T R2.16	--
1.23.x	PO82828T R .17	--
1.24.x	PO82828T R2.18	--
1.25.x	PO100913T R1.0	--
1.26.x	PO102048T R1.0	--
1.27.x	PO103462T R1.0	--
1.28.x	PO104846T R1.0	--
1.29.x	PO105926T V1.0	--

Version: "x" = Jede Zahl zwischen 0...9 / Any number between 0...9

2.2 PSS 4000 - Kopfmodule / PSS 4000 - Head modules								
Typ / Type ¹⁾ (Sach-Nr. / Order No.)	Beschreibung Description	HW- Version	PSS4000-FW (See Chapter 2.1)	Interner Prüfbericht Internal Test Report	Safety ³⁾ Characteristic	Sicherheits-Kennzahlen / Safety properties		
						PFD/PFH	Tmission = 10a	Tmission = 20a
PSSu H PLC1 FS SN SD (312070) PSSu H PLC1 FS SN SD-T (314070)	PLC-Kopfmodul für Failsafe und Standard mit SafetyNETp-Anschaltung PLC Head module for fail safe and standard with SafetyNETp interface	3	ab/from 1.2.x bis/until 1.27.x	PO85078T R1.0 PO105048T 1.0	SIL 3 PL "e" Burner	PFD Head PFH Head	1,67 x 10 ⁻⁵ 3,67 x 10 ⁻⁹ [1/h]	3,51 x 10 ⁻⁵ 4,14 x 10 ⁻⁹ [1/h]
PSSu H PLC1 FS SN SD-M12-T (314071)	PLC-Kopfmodul für Failsafe und Standard mit M12-SafetyNETp-Anschaltung PLC Head module for fail safe and standard with M12-SafetyNETp interface	1	ab/from 1.19.x bis/until 1.27.x	PO82828T R2.12 PO105048T 1.0	SIL 3 PL "e" Burner	PFD Head PFH Head	1,69 x 10 ⁻⁵ 3,71 x 10 ⁻⁹ [1/h]	3,54 x 10 ⁻⁵ 4,18 x 10 ⁻⁹ [1/h]
PSSu H PLC1 FS DP SN SD (312071)	PLC-Kopfmodul für Failsafe und Standard mit SafetyNETp- und Profibus –Slave-Anschaltung PLC Head module for fail safe and standard with SafetyNETp and Profibus slave interface	3	ab/from 1.2.x bis/until 1.27.x	PO85078T R1.0 PO105048T 1.0	SIL 3 PL "e" Burner	PFD Head PFH Head	1,67 x 10 ⁻⁵ 3,67 x 10 ⁻⁹ [1/h]	3,51 x 10 ⁻⁵ 4,14 x 10 ⁻⁹ [1/h]

2.2 PSS 4000 - Kopfmodule / PSS 4000 - Head modules

Typ / Type ¹⁾ (Sach-Nr. / Order No.)	Beschreibung Description	HW- Version	PSS4000-FW (See Chapter 2.1)	Interner Prüfbericht Internal Test Report	Safety ³⁾ Characteristic	Sicherheits-Kennzahlen / Safety properties		
						PFD/PFH	Tmission = 10a	Tmission = 20a
PSSu H PLC2 FS SN SD (312077) PSSu H PLC2 FS SN SD-T (314077)	PLC-Kopfmodul für Failsafe und Standard mit SafetyNETp-Anschaltung PLC Head module for fail safe and standard with SafetyNETp interface	1	ab/from 1.21.x	PO82828T R2.15 PO105048T 1.0	SIL 3 PL "e" Burner	PFD Head PFH Head	2,42 x 10 ⁻⁵	5,17 x 10 ⁻⁵
		2	ab/from 1.26.x	PO82828T R2.15 PO99439T R1.4 PO105048T 1.0			5,70 x 10 ⁻¹⁰ [1/h]	6,25 x 10 ⁻¹⁰ [1/h]
PSSu H FS SN SD (312085) PSSu H FS SN SD-T (314085)	Kopfmodul für Failsafe und Standard mit SafetyNETp-Anschaltung Head module for fail safe and standard with SafetyNETp interface	3	ab/from 1.2.x bis/until 1.27.x	PO85078T R1.0 PO105048T 1.0	SIL 3 PL "e" Burner	PFD Head PFH Head	1,67 x 10 ⁻⁵ 3,67 x 10 ⁻⁹ [1/h]	3,51 x 10 ⁻⁵ 4,14 x 10 ⁻⁹ [1/h]
PSSu H FS2 SN SD (312087) PSSu H FS2 SN SD-T (314087)	Kopfmodul für Failsafe und Standard mit SafetyNETp-Anschaltung Head module for fail safe and standard with SafetyNETp interface	1	ab/from 1.21.x	PO82828T R2.15 PO105048T 1.0	SIL 3 PL "e" Burner	PFD Head PFH Head	2,42 x 10 ⁻⁵	5,17 x 10 ⁻⁵
		2	ab/from 1.26.x	PO82828T R2.15 PO99439T R1.4 PO105048T 1.0			5,70 x 10 ⁻¹⁰ [1/h]	6,25 x 10 ⁻¹⁰ [1/h]
PSSu H FS SN SD- M12-T (314086)	Kopfmodul für Failsafe und Standard mit M12-SafetyNETp-Anschaltung Head module for fail safe and standard with M12-SafetyNETp interface	1	ab/from 1.19.x bis/until 1.27.x	PO82828T R2.12 PO105048T 1.0	SIL 3 PL "e" Burner	PFD Head PFH Head	1,69 x 10 ⁻⁵ 3,71 x 10 ⁻⁹ [1/h]	3,54 x 10 ⁻⁵ 4,18 x 10 ⁻⁹ [1/h]
PSSu H m F DP ETH SD (312060)	Multi-Kopfmodul für Failsafe mit Profibus –Slave- und Ethernet-Anschaltung Multi-Head module for fail safe with Profibus slave and Ethernet interface	3	ab/from 1.5.x bis/until 1.27.x	PO85078T R1.0 PO105048T 1.0	SIL 3 PL "e" Burner	PFD Head PFH Head	1,67 x 10 ⁻⁵ 3,67 x 10 ⁻⁹ [1/h]	3,51 x 10 ⁻⁵ 4,14 x 10 ⁻⁹ [1/h]
PSSu H m F DP SN SD (312065)	Multi-Kopfmodul für Failsafe mit Profibus –Slave- und SafetyNETp-Anschaltung MultiHead module for fail safe with Profibus slave and SafetyNETp interface	3	ab/from 1.2.x bis/until 1.27.x	PO85078T R1.0 PO105048T 1.0	SIL 3 PL "e" Burner	PFD Head PFH Head	1,67 x 10 ⁻⁵ 3,67 x 10 ⁻⁹ [1/h]	3,51 x 10 ⁻⁵ 4,14 x 10 ⁻⁹ [1/h]

2.2 PSS 4000 - Kopfmodule / PSS 4000 - Head modules

Typ / Type ¹⁾ (Sach-Nr. / Order No.)	Beschreibung Description	HW- Version	PSS4000-FW (See Chapter 2.1)	Interner Prüfbericht Internal Test Report	Safety ³⁾ Characteristic	Sicherheits-Kennzahlen / Safety properties		
						PFD/PFH	Tmission = 10a	Tmission = 20a
PSSu H m F DPsafe SN SD (312066)	Multi-Kopfmodul für Failsafe mit Profibus –Slave- und SafetyNETp-Anschaltung Multi-Head module for fail safe with Profibus slave and SafetyNETp interface	3	ab/from 1.7.x bis/until 1.27.x	PO82828T R1.9 PO105048T 1.0	SIL 3 PL “e” Burner	PFD Head PFH Head	1,67 x 10 ⁻⁵ 3,67 x 10 ⁻⁹ [1/h]	3,51 x 10 ⁻⁵ 4,14 x 10 ⁻⁹ [1/h]

2.3 PSS4000 - Kopfmodule IP67 / PSS4000 - Head modules IP67

Typ / Type ¹⁾ (Sach-Nr. / Order No.)	Beschreibung Description	Version ²⁾ HW / FW	PSS4000-FW (See Chapter 2.1)	Interner Prüfbericht Internal Test Report	Safety ³⁾ Characteristic	Sicherheits-Kennzahlen / Safety properties		
						PFD/PFH	Tmission = 10a	Tmission = 20a
PSS67 PLC1 16FDI (316020)	IP67-PLC-Kopfmodul Failsafe mit SafetyNETp-Anschaltung IP67 PLC Head module for fail safe with SafetyNETp interface	1 / 13	ab/from 1.18.x bis/until 1.27.x	PO92852T V1.0	SIL 3 PL “e” Burner	PFD Head PFH Head <u>Inputs:</u> PFD single PFH single PFD double PFH double PFD beam pulsed PFH beam pulsed PFD double pulsed PFH double pulsed	2,35 x 10 ⁻⁵ 5,33 x 10 ⁻¹⁰ [1/h] 5,15 x 10 ⁻⁵ 1,17 x 10 ⁻⁹ [1/h] 4,20 x 10 ⁻⁶ 9,62 x 10 ⁻¹¹ [1/h] 8,14 x 10 ⁻⁶ 1,84 x 10 ⁻¹⁰ [1/h] 3,33 x 10 ⁻⁶ 7,63x 10 ⁻¹¹ [1/h]	5,01 x 10 ⁻⁵ 6,06 x 10 ⁻¹⁰ [1/h] 1,03 x 10 ⁻⁴ 1,18 x 10 ⁻⁰⁹ [1/h] 8,47 x 10 ⁻⁶ 9,75 x 10 ⁻¹¹ [1/h] 1,63 x 10 ⁻⁵ 1,85 x 10 ⁻¹⁰ [1/h] 6,72 x 10 ⁻⁶ 7,75 x 10 ⁻¹¹ [1/h]
PSS67 IO1 16FDI (316010)	IP67-Eingangsbaugruppe 16 digitale Kanäle, 24 VDC, Failsafe mit SafetyNETp-Anschaltung IP67 Input module 16 digital channels, 24 VDC, IP67 with SafetyNETp interface	1 / 13	ab/from 1.16.x bis/until 1.27.x	PO90952T	SIL 3 PL “e” Burner	PFD Head PFH Head <u>Inputs:</u> PFD single PFH single PFD double PFH double PFD beam pulsed PFH beam pulsed PFD double pulsed PFH double pulsed	2,35 x 10 ⁻⁵ 5,33 x 10 ⁻¹⁰ [1/h] 5,15 x 10 ⁻⁵ 1,17 x 10 ⁻⁹ [1/h] 4,20 x 10 ⁻⁶ 9,62 x 10 ⁻¹¹ [1/h] 8,14 x 10 ⁻⁶ 1,84 x 10 ⁻¹⁰ [1/h] 3,33 x 10 ⁻⁶ 7,63x 10 ⁻¹¹ [1/h]	5,01 x 10 ⁻⁵ 6,06 x 10 ⁻¹⁰ [1/h] 1,03 x 10 ⁻⁴ 1,18 x 10 ⁻⁰⁹ [1/h] 8,47 x 10 ⁻⁶ 9,75 x 10 ⁻¹¹ [1/h] 1,63 x 10 ⁻⁵ 1,85 x 10 ⁻¹⁰ [1/h] 6,72 x 10 ⁻⁶ 7,75 x 10 ⁻¹¹ [1/h]



Rail

2.4 PSS 4000 - Aktive Elektronikmodule / PSS 4000 - Active electronic moduls

Typ / Type ¹⁾ (Sach-Nr. / Order No.)	Beschreibung Description	Version HW / FW	Interner Prüfbericht Internal Test Report	Safety ³⁾ Characteristic	Sicherheits-Kennzahlen / Safety properties		
					PFD/PFH	T _{mission} = 10a	T _{mission} = 20a
PSSu K F EI (312433)	I/O-Modul für Motion-Auswertung 2 Eingang Näherungsschaltern 1 Eingang Inkrementalgeber 2 Digitale FS Ausg. (DO), einpolig, 0.5A 1 Kaskadiereinausgang I/O module for Motion monitoring 2 inputs proximity switches 1 input incremental encoder 2 digital FS outputs (DO), single-pole 0.5 A 1 cascading output	1 / 3 2 / 3	PO86670T R 1.3 PO99630T R 1.0 PO99439T R 1.1 PO104846T R1.0	SIL 2 PL "d"	PFD INC single input PFH INC single input	8,00 x 10 ⁻⁴ 2,46 x 10 ⁻⁸ [1/h]	1,61 x 10 ⁻³ 1,83 x 10 ⁻⁸ [1/h]
				SIL 3 PL "e"	PFD INC double input PFH INC double input	5,29 x 10 ⁻⁵ 1,23 x 10 ⁻⁹ [1/h]	1,11 x 10 ⁻⁴ 1,32 x 10 ⁻⁹ [1/h]
				SIL 3 PL "e"	PFD Sinus single input PFH Sinus single input	1,15 x 10 ⁻⁵ 2,6 x 10 ⁻⁹ [1/h]	2,3 x 10 ⁻⁶ 2,66 x 10 ⁻⁹ [1/h]
PSSu K F EI CV (312434)	I/O-Modul für Motion-Auswertung 2 Eingang Näherungsschaltern 1 Eingang Inkrementalgeber 2 Digitale FS Ausg. (DO), einpolig, 0.5A 1 Kaskadiereinausgang	1 / 3 2 / 3	PO86670T R 1.4 PO99630T R 1.0 PO99439T R 1.1 PO104846T R1.0	SIL 2 PL "d"	PFD INC single input PFH INC single input	8,00 x 10 ⁻⁴ 2,46 x 10 ⁻⁸ [1/h]	1,61 x 10 ⁻³ 1,83 x 10 ⁻⁸ [1/h]
				SIL 3 PL "e"	PFD INC double input PFH INC double input	5,29 x 10 ⁻⁵ 1,23 x 10 ⁻⁹ [1/h]	1,11 x 10 ⁻⁴ 1,32 x 10 ⁻⁹ [1/h]
PSSu K F EI CV-T (314434)	Übertragung des Zähleristwerts (CV) über Modulbus I/O module for Motion monitoring 2 inputs proximity switches 1 input incremental encoder 2 digital FS outputs (DO), single-pole 0.5 A 1 cascading output Transmission of counter value (CV) via module bus	1 / 1 2 / 3		SIL 3 PL "e"	PFD Sinus single input PFH Sinus single input	1,15 x 10 ⁻⁵ 2,6 x 10 ⁻⁹ [1/h]	2,3 x 10 ⁻⁶ 2,66 x 10 ⁻⁹ [1/h]
				SIL 2 PL "d"	PFD DO single output PFH DO single output	3,77 x 10 ⁻⁶ 8,65 x 10 ⁻¹¹ [1/h]	7,63 x 10 ⁻⁶ 8,81 x 10 ⁻¹¹ [1/h]
PSSu K F FCU (312435)	I/O-Modul, 12 Digitale Eingänge (DI) 2 Testtakteausgänge, 2 Digitale Ausg. (DO), einpolig, 2A 2 Digitale Ausg. (DOZ), zweipolig,	3 / 7	PO85078T R1.2 PO90422T R1.0 PO104846T R1.0	SIL 2 PL "d"	PFD DI single input PFH DI single input	1,56 x 10 ⁻⁴ 3,55 x 10 ⁻⁹ [1/h]	3,11 x 10 ⁻⁴ 3,55 x 10 ⁻⁹ [1/h]
				SIL 3 PL "e"	PFD DI double input PFH DI double input	3,14 x 10 ⁻⁶ 7,21 x 10 ⁻⁹ [1/h]	6,35 x 10 ⁻⁵ 7,31 x 10 ⁻⁹ [1/h]
				SIL 2 PL "d"	PFD DO single output PFH DO single output	3,77 x 10 ⁻⁶ 8,65 x 10 ⁻¹¹ [1/h]	7,63 x 10 ⁻⁶ 8,81 x 10 ⁻¹¹ [1/h]

2.4 PSS 4000 - Aktive Elektronikmodule / PSS 4000 - Active electronic moduls

Typ / Type ¹⁾ (Sach-Nr. / Order No.)	Beschreibung Description	Version HW / FW	Interner Prüfbericht Internal Test Report	Safety ³⁾ Characteristic	Sicherheits-Kennzahlen / Safety properties		
					PFD/PFH	T _{mission} = 10a	T _{mission} = 20a
	3A I/O Module, 12 Digital inputs (DI), 2 Test pulse outputs, 2 Digital outputs, single pole (DO), 2A 2 Digital outputs, dual pole (DOZ), 3A			SIL 3 PL "e"	PFD DO double output PFH DO double output	3,50 x 10 ⁻⁶ 8,03 x 10 ⁻¹¹ [1/h]	7,08 x 10 ⁻⁶ 8,17 x 10 ⁻¹¹ [1/h]
				SIL 3 PL "e"	PFD DOZ double output PFH DOZ double output	3,37 x 10 ⁻⁶ 7,72 x 10 ⁻¹¹ [1/h]	6,81 x 10 ⁻⁶ 7,85 x 10 ⁻¹¹ [1/h]
PSSu K F FAU B (312420)	I/O-Modul mit PSEnvip-Basis-Auswerteeinheit 4 Digitale Eingänge (DI) 2 Testtaktausgänge, 2 Digitale Ausg. (DO), einpolig, 1,75A 2 Digitale Ausg. (DOZ), zweipolig, 3A I/O Module with PSEnvip analyzing unit (basic) 4 Digital inputs (DI), 2 Test pulse outputs, 2 Digital outputs, single pole (DO), 1,75A 2 Digital outputs, dual pole (DOZ), 3A	4 / 2.3	PO86241T R1.1 PO93517T PO95290T	SIL 2 PL "d"	PFD DI single input PFH DI single input	6,98 x 10 ⁻⁴ 1,59 x 10 ⁻⁸ [1/h]	1,39 x 10 ⁻³ 1,59 x 10 ⁻⁸ [1/h]
				SIL 3 PL "e"	PFD DI double input PFH DI double input	1,46 x 10 ⁻⁵ 3,40 x 10 ⁻¹⁰ [1/h]	3,04 x 10 ⁻⁵ 3,61 x 10 ⁻¹⁰ [1/h]
				SIL 2 PL "d"	PFD DO single output PFH DO single output	5,00 x 10 ⁻⁴ 1,14 x 10 ⁻⁸ [1/h]	1,00 x 10 ⁻³ 1,14 x 10 ⁻⁸ [1/h]
				SIL 3 PL "e"	PFD DO double output PFH DO double output	1,03 x 10 ⁻⁵ 2,39 x 10 ⁻¹⁰ [1/h]	2,13 x 10 ⁻⁵ 2,50 x 10 ⁻¹⁰ [1/h]
				SIL 3 PL "e"	PFD DOZ double output PFH DOZ double output	9,90 x 10 ⁻⁶ 2,29 x 10 ⁻¹⁰ [1/h]	2,04 x 10 ⁻⁵ 2,39 x 10 ⁻¹⁰ [1/h]
				Nicht Gegenstand der Prüfung / not in the scope: IEC 61511-1-3, EN 298, EN 230, EN 13243, EN 692 und EN 693			
PSSu K F FAU P (312421)	I/O-Modul mit PSEnvip-Produktiv-Auswerteeinheit 4 Digitale Eingänge (DI) 2 Testtaktausgänge, 2 Digitale Ausg. (DO), einpolig, 1,75A 2 Digitale Ausg. (DOZ), zweipolig, 3A I/O Module with PSEnvip analyzing unit (productive) 4 Digital inputs (DI), 2 Test pulse outputs, 2 Digital outputs, single pole (DO), 1,75A 2 Digital outputs, dual pole (DOZ), 3A	4 / 2.3	PO86241T R1.1 PO93517T PO95290T	SIL 2 PL "d"	PFD DI single input PFH DI single input	6,98 x 10 ⁻⁴ 1,59 x 10 ⁻⁸ [1/h]	1,39 x 10 ⁻³ 1,59 x 10 ⁻⁸ [1/h]
				SIL 3 PL "e"	PFD DI double input PFH DI double input	1,46 x 10 ⁻⁵ 3,40 x 10 ⁻¹⁰ [1/h]	3,04 x 10 ⁻⁵ 3,61 x 10 ⁻¹⁰ [1/h]
				SIL 2 PL "d"	PFD DO single output PFH DO single output	5,00 x 10 ⁻⁴ 1,14 x 10 ⁻⁸ [1/h]	1,00 x 10 ⁻³ 1,14 x 10 ⁻⁸ [1/h]
				SIL 3 PL "e"	PFD DO double output PFH DO double output	1,03 x 10 ⁻⁵ 2,39 x 10 ⁻¹⁰ [1/h]	2,13 x 10 ⁻⁵ 2,50 x 10 ⁻¹⁰ [1/h]
				SIL 3 PL "e"	PFD DOZ double output PFH DOZ double output	9,90 x 10 ⁻⁶ 2,29 x 10 ⁻¹⁰ [1/h]	2,04 x 10 ⁻⁵ 2,39 x 10 ⁻¹⁰ [1/h]
				Nicht Gegenstand der Prüfung / not in the scope: IEC 61511-1-3, EN 298, EN 230, EN 13243, EN 692 und EN 693			



Rail

2.5 PSS 4000 - Elektronikmodule / PSS 4000 - Electronic modules

Typ / Type ¹⁾ (Sach-Nr. / Order No.)	Beschreibung Description	Version HW / FW	Interner Prüfbericht Internal Test Report	Safety ³⁾ Characteristic	Sicherheits-Kennzahlen / Safety properties		
					PFD/PFH	Tmission = 10a	Tmission = 20a
PSSu E F AI I (312260) PSSu E F AI I-T (314260)	Analog-Modul, 0 ... 25 mA Analog module, 0 ... 25 mA	3 / 3	PO82834T R1.0 PO92853T R1.0 PO104846T R1.0	SIL 2 Burner	PFD single input PFH single input	$6,88 \times 10^{-4}$ $1,56 \times 10^{-8} [1/h]$	$1,37 \times 10^{-3}$ $1,56 \times 10^{-8} [1/h]$
				SIL 3 PL "e" Burner	PFD double input PFH double input	$1,43 \times 10^{-5}$ $3,92 \times 10^{-9} [1/h]$	$2,99 \times 10^{-5}$ $4,37 \times 10^{-9} [1/h]$
PSSu E F AI U (312265) PSSu E F AI U-T (314265)	Analog-Modul, -10 ... +10 V Analog module, -10 ... +10 V	3 / 3	PO82834T R1.0 PO92853T R1.0 PO104846T R1.0	SIL 3 PL "e" Burner	PFD double input PFH double input	$1,43 \times 10^{-5}$ $3,92 \times 10^{-9} [1/h]$	$2,99 \times 10^{-5}$ $4,37 \times 10^{-9} [1/h]$
				SIL 3 PL "e" Burner	PFD double input PFH double input	$1,43 \times 10^{-5}$ $3,92 \times 10^{-9} [1/h]$	$2,99 \times 10^{-5}$ $4,37 \times 10^{-9} [1/h]$
PSSu E F AI PVM I-T (314298)	Spitzenwert-Analog-Modul, 0 ... 25 mA Peak Value Analog module, 0 ... 25 mA,	2 / 2	PO82834T R1.0 PO90027T R1.0	SIL 3 PL "e" Burner	PFD double input PFH double input	$1,43 \times 10^{-5}$ $3,92 \times 10^{-9} [1/h]$	$2,99 \times 10^{-5}$ $4,37 \times 10^{-9} [1/h]$
PSSu E F INC (312280) PSSu E F INC -T (314280) PSSu K F INC (312437)	Zähler-Modul, für Inkrementalgeber Counter module, for incremental encoders	4 / 3	PO82828T R2.0 PO104846T R1.0	SIL 3 PL "e" Burner	PFD double input PFH double input	$2,80 \times 10^{-6}$ $3,25 \times 10^{-9} [1/h]$	$5,62 \times 10^{-6}$ $3,34 \times 10^{-9} [1/h]$
				SIL 3 PL "e" Burner	PFD double input PFH double input	$2,80 \times 10^{-6}$ $3,25 \times 10^{-9} [1/h]$	$5,62 \times 10^{-6}$ $3,34 \times 10^{-9} [1/h]$
				SIL 3 PL "e" Burner	PFD double input PFH double input	$2,80 \times 10^{-6}$ $3,25 \times 10^{-9} [1/h]$	$5,62 \times 10^{-6}$ $3,34 \times 10^{-9} [1/h]$
PSSu E F ABS SSI (312275) PSSu E F ABS SSI -T (314275)	Zähler-Modul, für SSI-Geber Counter module, for SSI encoders	2 / 2	PO82828T R2.0 PO104846T R1.0	SIL 3 PL "e" Burner	PFD double input PFH double input	$2,21 \times 10^{-6}$ $2,56 \times 10^{-9} [1/h]$	$4,43 \times 10^{-6}$ $2,61 \times 10^{-9} [1/h]$
				SIL 3 PL "e" Burner	PFD double input PFH double input	$2,21 \times 10^{-6}$ $2,56 \times 10^{-9} [1/h]$	$4,43 \times 10^{-6}$ $2,61 \times 10^{-9} [1/h]$



Rail

2.6 PSS 4000 - Spannungsversorgungs-Modul / PSS 4000 - Powersupply modules

Typ / Type ¹⁾ (Sach-Nr. / Order No.)	Beschreibung / Description	Version HW / SW	Interner Prüfbericht Internal Test Report	Safety ³⁾ Characteristic
PSSu E F PS2 (312192) PSSu E F PS2-T (314192)	Spannungsversorgungs-Modul (Peripherie 24 V und System 5V) Powersupply module (Periphery 24 V and System 5V)	2 / 3	PO82828T R1.7	Kein Sicherheitsteil No safety device

2.7 PSS 4000 - Fail-Safe-Funktionsbausteine / PSS 4000 - Failsafe function blocks

Name	Funktion/Function	Vers.	CRC	Datum/Date (Last Modif.)	Interner Prüfbericht Internal Test Report	Normen ⁴⁾ Standards	Safety ³⁾ Characteristic
FS_AbsoluteEncoder	Überwachung des Moduls PSSu E F ABS SSI Monitoring of PSSu E F ABS SSI module	V1.0.x	14B7	30.10.2009	PO82833T	--	SIL3 / PL e
		V1.1.x	02BD	15.07.2010	PO82833T	--	SIL3 / PL e
		V1.2.x	A36C	09.05.2012	PO82833T	--	SIL3 / PL e
FS_AnalogueInputDual	Redundante Analogwerte Überwachung Redundant analogue input monitoring	V1.0.x	F220	02.11.2009	PO82833T	--	SIL3 / PL e
		V1.1.x	32BD	15.07.2010	PO82833T	--	SIL3 / PL e
FS_AnalogueInputSingle	Analogwert-Überwachung Analogue input monitoring	V1.0.x	689C	02.11.2009	PO82833T	--	SIL3 / PL e
		V1.1.x	545A	15.07.2010	PO82833T	--	SIL3 / PL e
FS_BrakeTestMonitoring	Bremsentest-Überwachung Brake test monitoring	V1.0.x	8A97	09.04.2018	PO82833T R1.10	H	PL d
FS_BurnerManagementSystem_PL	Feuerungsautomat (IEC 61131-Programmierung) Burner Management System (IEC 61131 programming)	V1.0.x	0977	10.08.2011	C 1295-03/24	L	SIL3 Brenner SIL3 Burner
FS_BurnerManagementSystem	Feuerungsautomat (Multi-Programmierung) Burner Management System (Multi programming)	V1.0.x	15B7	10.08.2011	C 1295-03/24	L	SIL3 Brenner SIL3 Burner
FS_Cam	Einzelnockenbaustein Single cam function block	V1.0.x	D89E	19.09.2013	PO82833T	--	SIL3 / PL e
FS_CamController	Elektronisches Nockenschaltwerk Electronic cam controller	V1.2.x	E3C4	03.09.2012	PO82833T R1.9	C, D	SIL3 / PL e
		V1.3.x	993C	06.11.2023	PO103276T	C, D	SIL3 / PL e



Rail

2.7 PSS 4000 - Fail-Safe-Funktionsbausteine / PSS 4000 - Failsafe function blocks

Name	Funktion/Function	Vers.	CRC	Datum/Date (Last Modif.)	Interner Prüfbericht Internal Test Report	Normen ⁴⁾ Standards	Safety ³⁾ Characteristic
FS_CamEvaluation	Überwachung eines mechanischen Nockenschaltwerk Monitoring of mechanical cam switches	V1.0.x	3931	31.05.2010	PO82833T R1.9	C, D	SIL3 / PL e
FS_CounterDual	Redundante, diversitäre Zählerwerte-Überwachung Redundant, diverse counter monitoring	V1.0.x	A304	30.10.2009	PO82833T	--	SIL3 / PL e
		V1.1.x	0CD5	15.07.2010	PO82833T	--	SIL3 / PL e
		V1.2.x	9EE2	29.06.2012	PO82833T	--	SIL3 / PL e
FS_CRC	16 Bit CRC-Berechnung 16Bit CRC Calculation	V1.0.x	104C	06.04.2011	PO97056T R1.0	K	SIL3 / PL e
FS_CycleModeLightCurtain ¹⁾	Taktbetrieb Break mode	V1.0.x	F222	25.03.2010	PO82833T R1.9	B, C, D, E, G, 1)	SIL3 / PL e
FS_EI_Basic	Encoder Interface: Basisfunktionen Encoder interface: Basic functions	V1.0.x	8720	07.11.2014	PO86653T	--	SIL3 / PL e
FS_EI_SDIM	Encoder Interface: SDI-Überwachung Encoder interface: SDI monitoring	V1.0.x	1B34	06.11.2014	PO86653T	--	SIL3 / PL e
FS_EI_SOSM	Encoder Interface: SOSM-Überwachung Encoder interface: SOSM monitoring	V1.0.x	2BEE	06.11.2014	PO86653T	--	SIL3 / PL e
FS_EI_SSM0	Encoder Interface: SSM0-Überwachung Encoder interface: SSM0 monitoring	V1.0.x	2DAE	06.11.2014	PO86653T	--	SIL3 / PL e
FS_EI_SSM1_SSRM	Encoder Interface: SSM1- und SSR-Überwachung Encoder interface: SSM1 and SSR monitoring	V1.0.x	473B	28.01.2015	PO86653T	--	SIL3 / PL e
FS_EmergencyStop	Not-Halt-Überwachung Emergency stop monitoring	V1.0.x	2FD1	28.10.2009	PO82833T	--	SIL3 / PL e
		V1.1.x	EA57	21.04.2010	PO82833T	--	SIL3 / PL e
FS_EmergencyStop_PLC	Not-Halt-Überwachung Emergency stop monitoring	V1.0.x	E73B	01.04.2011	PO82833T	--	SIL3 / PL e
FS_EnableSwitch	Zustimmungsschalter- Überwachung Enable switch monitoring	V1.0.x	1539	28.10.2009	PO82833T	--	SIL3 / PL e
		V1.1.x	7C1A	21.04.2010	PO82833T	--	SIL3 / PL e
FS_EnableSwitch_PLC	Zustimmungsschalter- Überwachung Enable switch monitoring	V1.0.x	EBF9	04.04.2011	PO82833T	--	SIL3 / PL e

2.7 PSS 4000 - Fail-Safe-Funktionsbausteine / PSS 4000 - Failsafe function blocks

Name	Funktion/Function	Vers.	CRC	Datum/Date (Last Modif.)	Interner Prüfbericht Internal Test Report	Normen ⁴⁾ Standards	Safety ³⁾ Characteristic
FS_FBL_Monitoring	Rückführkreisüberwachung Feedback loop monitoring	V1.0.x	FF2A	03.09.2014	PO82833T	--	SIL3 / PL e
FS_FBL_Monitoring_PLC	Rückführkreisüberwachung (PLC) Feedback loop monitoring (PLC)	V1.0.x	4DA2	02.09.2014	PO82833T	--	SIL3 / PL e
FS_FootSwitch	Fußschalter-Überwachung Foot switch monitoring	V1.0.x	934D	28.10.2009	PO82833T	--	SIL3 / PL e
		V1.1.x	D8D6	21.04.2010	PO82833T	--	SIL3 / PL e
FS_FootSwitch_PLC	Fußschalter-Überwachung Foot switch monitoring	V1.0.x	BDE5	04.04.2011	PO82833T	--	SIL3 / PL e
FS_IncrementalEncoder	Überwachung des Moduls PSSu E F INC Monitoring of PSSu E F INC module	V1.0.x	3CD6	30.10.2009	PO82833T	--	SIL3 / PL e
		V1.1.x	5B9C	15.07.2010	PO82833T	--	SIL3 / PL e
		V1.2.x	0C30	09.05.2012	PO82833T	--	SIL3 / PL e
FS_KeyInPocket_Manager	Verwaltung des „Key in Pocket“-Systems Management of the „Key-in-Pocket“ system	V1.0.x	704D	26.08.2022	PO100336T R1.0	--	SIL2 / PL d
FS_KeyInPocket_SignInOut	Eintragen in und Austragen aus der Anmeldeliste Sign in to and sign out of the sign in list	V1.0.x	78B2	26.08.2022	PO100336T R1.0	--	SIL2 / PL d
FS_KeyInPocket_BlindSpotCheck	Toter-Winkel-Prüfung Blind spot check	V1.0.x	A00C	26.08.2022	PO100336T R1.0	--	SIL2 / PL d
FS_LightCurtain	Lichtvorhang-Überwachung Light curtain monitoring	V1.0.x	50C5	28.10.2009	PO82833T	--	SIL3 / PL e
		V1.1.x	5963	21.04.2010	PO82833T	--	SIL3 / PL e
FS_LightCurtain_PLC	Lichtvorhang-Überwachung Light curtain monitoring	V1.0.x	9E5F	04.04.2011	PO82833T	--	SIL3 / PL e
FS_LimitValueMonitoring	Analogwert-Grenzwertüberwachung Analogue input limit monitoring -32768 ... 32767 (INT)	V1.0.x	E8D5	02.11.2009	PO82833T	--	SIL3 / PL e
		V1.1.x	6E88	14.07.2010	PO82833T	--	SIL3 / PL e
FS_LimitValueMonitoringHighRange	Analogwert-Grenzwertüberwachung Analogue input limit monitoring -2147483648 ... +2147483647 (DINT)	V1.0.x	A6F2	30.05.2012	PO82833T	--	SIL3 / PL e



Rail

2.7 PSS 4000 - Fail-Safe-Funktionsbausteine / PSS 4000 - Failsafe function blocks

Name	Funktion/Function	Vers.	CRC	Datum/Date (Last Modif.)	Interner Prüfbericht Internal Test Report	Normen ⁴⁾ Standards	Safety ³⁾ Characteristic
FS_MSO_PITreader_Keypad	Betriebsartenwahl mit PITreader & Tastenfeld Operating mode selection with PITreader & keypad	V1.0.x	6E8A	07.04.2020	PO95881T R1.1 PO96250T R1.0	--	SIL2 / PL d
FS_MSO_PITreader_Keypad_PLC	Betriebsartenwahl mit PITreader & Tastenfeld (PLC) Operating mode selection with PITreader & keypad (PLC)	V1.0.x	D0AB	07.04.2020	PO95881T R1.1 PO96250T R1.0	--	SIL2 / PL d
FS_MSO_PITreader_Visu	Betriebsartenwahl mit PITreader und Visualisierung Operating mode selection with PITreader and visualization	V1.0.x	1462	23.04.2021	PO97480T R1.0	--	SIL2 / PL d
FS_Muting	Zeitlich begrenzte Überbrückung von Sicherheitsfunktionen (BWS/AOS) ohne Prozessunterbrechung (Muting) Temporary automatic suspension of safety function(s).	V1.0.x	9E29	10.06.2011	PO82833T	G	SIL3 / PL e
FS_Muting_PLC	Zeitlich begrenzte Überbrückung von Sicherheitsfunktionen (BWS/AOS) ohne Prozessunterbrechung (Muting) Temporary automatic suspension of safety function(s).	V1.0.x	54D4	08.06.2011	PO82833T	G	SIL3 / PL e
FS_OperatingModeSelectorSwitch	Betriebsartenwahlschalter- Überwachung Operating mode selector switch monitoring	V1.0.x	E643	29.10.2009	PO82833T	--	SIL3 / PL e
		V1.1.x	EDFD	22.04.2010	PO82833T	--	SIL3 / PL e
FS_OperatingModeSelectorSwitch_PLC	Betriebsartenwahlschalter- Überwachung Operating mode selector switch monitoring	V1.0.x	8C11	04.04.2011	PO82833T	--	SIL3 / PL e
FS_OutputFBL	Rückführkreis-Überwachung Feedback loop monitoring	V1.0.x	DEA8	29.10.2009	PO82833T	--	SIL3 / PL e
		V1.1.x	B3A7	22.04.2010	PO82833T	--	SIL3 / PL e
FS_OutputFBL_PLC	Rückführkreis-Überwachung Feedback loop monitoring	V1.0.x	C691	06.04.2011	PO82833T	--	SIL3 / PL e
FS_PeakValueMeasurement	Überwachung des Moduls PSSu E F AI PVM (I-T/U-T) (Messung von Peak-Werten) Monitoring of PSSu E F AI PVM (I-T/U-T) module (Peak value measurement)	V2.0.x	F828	17.06.2016	PO82833T	--	SIL3 / PL e
FS_PositionToAngle	Sicherer Winkel Safe angle	V1.2.x	F629	03.09.2012	PO82833T R1.9	C, D	SIL3 / PL e

2.7 PSS 4000 - Fail-Safe-Funktionsbausteine / PSS 4000 - Failsafe function blocks

Name	Funktion/Function	Vers.	CRC	Datum/Date (Last Modif.)	Interner Prüfbericht Internal Test Report	Normen ⁴⁾ Standards	Safety ³⁾ Characteristic
FS_PressOperatingModes	Pressenbetriebsarten Press operating modes	V1.0.x	4AD4	11.05.2010	PO82833T R1.9	C, D	SIL3 / PL e
FS_PSEncs	PSEncode max. 3 Betätiger PSEncode max. 3 actuators	V1.0.x	A8C3	26.02.2013	PO82833T R1.9	--	SIL3 / PL e
FS_Reset	Manuelle Quittierung/manueller Start Manual reset/manual start	V1.0.x	6CAE	25.05.2010	PO82833T	--	SIL3 / PL e
FS_RobotSafeguard	Robotersicherheitslogik Robot safety logic	V1.0.x	E8A9	09.04.2018	PO82833T R1.10	H	SIL3 / PL e
FS_SafeEthernetConnection	Sichere Kommunikation über Industrial-Ethernet Safe communication via Industrial-Ethernet	V1.0.x	6DDD	06.04.2011	PO97056T R1.0	K	SIL3 / PL e
FS_SafeEthernetConnection2	Sichere Kommunikation über Industrial-Ethernet Safe communication via Industrial-Ethernet	V1.0.x	F5DC	16.10.2025	PO106099T R1.0	K	SIL3 / PL e
FS_SafetyGate	Schutztür-Überwachung Safety gate monitoring	V1.0.x	C128	28.10.2009	PO82833T	--	SIL3 / PL e
		V1.1.x	ADDB	21.04.2010	PO82833T	--	SIL3 / PL e
FS_SafetyGate_PLC	Schutztür-Überwachung Safety gate monitoring	V1.0.x	32EE	04.04.2011	PO82833T	--	SIL3 / PL e
FS_SafetyValve	Ansteuerung und Überw. von Sicherheitsventilen Control and monitoring of safety valves	V1.0.x	E6EF	25.03.2010	PO82833T R1.9	B, C, D, F	SIL3 / PL e
FS_Scaling	Analogwert-Skalierung Analogue input scaling -32768 ... 32767 (INT)	V1.0.x	7585	02.11.2009	PO82833T	--	SIL3 / PL e
		V1.1.x	7759	15.07.2010	PO82833T	--	SIL3 / PL e
FS_ShiftPositionRange	Bereichsanpassung Range adaption	V1.0.x	16A7	15.07.2010	PO82833T R1.9	C, D	SIL3 / PL e
FS_TwoHandControl	Zweihand-Überwachung Two-hand monitoring	V1.0.x	10B8	25.03.2010	PO82833T R1.9	A, B, C, D, F	SIL3 / PL e
		V1.1.x	F8A6	25.05.2012	PO82833T R1.9	A, B, C, D, F	SIL3 / PL e



Rail

2.7 PSS 4000 - Fail-Safe-Funktionsbausteine / PSS 4000 - Failsafe function blocks

Name	Funktion/Function	Vers.	CRC	Datum/Date (Last Modif.)	Interner Prüfbericht Internal Test Report	Normen ⁴⁾ Standards	Safety ³⁾ Characteristic
FS_TwoHandControl_PLC	Zweihand-Überwachung Two-hand monitoring	V1.0.x	AA4A	07.11.2012	PO82833T R1.9	A, B, C, D, F	SIL3 / PL e
FS_Voting2oo3	2 von 3 Überwachung Monitoring of 2 out of 3 voting	V1.0.x	AFC1	02.11.2009	PO82833T	--	SIL3 / PL e
		V1.1.x	ED56	15.07.2010	PO82833T	--	SIL3 / PL e

Version: "x" = Jede Zahl zwischen 0...9 / Any number between 0...9

- 1) Der Softwarebaustein FS_CycleModeLightCurtain wurde in Verbindung mit dem FS_LightCurtain CRC:5963 geprüft.
Software function module FS_CycleModeLightCurtain was tested in conjunction with FS_LightCurtain CRC:5963.



Rail

3 PSSu

3.1 PSSu - Kopfmodule / PSSu - Head module

Typ / Type ¹⁾ (Sach-Nr. / Order No.)	Beschreibung Description	Version ²⁾ HW / FW	Interner Prüfbericht Internal Test Report	Safety ³⁾ Characteristic	Sicherheits-Kennzahlen / Safety properties		
					PFD/PFH	T _{mission} = 10a	T _{mission} = 20a
PSSu H SB (312010)	Kopfmodul mit SafetyBUSp- Anschaltung Head module with SafetyBUSp interface	2 / 16	PO81286 R1.0 C1329-00/06	SIL 3 PL "e" Burner	PFD double input	1,88 x 10 ⁻⁵	3,95 x 10 ⁻⁵
PSSu H SB-T (314010)					PFH double input	2,56 x 10 ⁻⁹ [1/h]	2,99 x 10 ⁻⁹ [1/h]
PSSu H F PN (312043)	Kopfmodul mit PROFINET-Schnittstelle mit PROFIsafe-Profil Head module with ProfiNet interface with PROFIsafe profile	3 / 2	PO84211T R1.0 C1329-00/06	SIL 3 Burner	PFD	1,88 x 10 ⁻⁵	3,95 x 10 ⁻⁵
		3 / 5			PFD	1,88 x 10 ⁻⁵	3,95 x 10 ⁻⁵
					PFH	2,56 x 10 ⁻⁹ [1/h]	2,99 x 10 ⁻⁹ [1/h]

3.2 PSSu - Spannungsversorgungs-Modul / PSSu - Powersupply modules

Typ / Type ¹⁾ (Sach-Nr. / Order No.)	Beschreibung Description	Version ²⁾ HW / FW	Interner Prüfbericht Internal Test Report	Safety ³⁾ Characteristic
PSSu E F PS (312190)	Spannungsversorgungs-Modul (Peripherie 24 V und System 5V) Powersupply module (Periphery 24 V and System 5V)	6 / 12	PO81286 R1.0 C1329-00/06	Kein Sicherheitbauteil No safety device
PSSu E F PS-T (314190)				
PSSu E F PS1 (312191)	Spannungsversorgungs-Modul (Peripherie 24 V und System 5V) Powersupply module (Periphery 24 V and System 5V)	6 / 12	PO81286 R1.0 C1329-00/06	Kein Sicherheitbauteil No safety device
PSSu E F PS1-T (314191)				
PSSu E F PS-P (312185)	Spannungsversorgungs-Modul (Peripherie 24 V) Powersupply module (Periphery 24 V)	6 / 12	PO81286 R1.0 C1329-00/06	Kein Sicherheitbauteil No safety device
PSSu E F PS-P-T (314185)				



Rail

4 PSS4000 + PSSu - Elektronikmodule / PSS4000 + PSSu - Electronic modules

Typ / Type ¹⁾ (Sach-Nr. / Order No.)	Beschreibung / Description	Version ²⁾ HW / FW	Interner Prüfbericht Internal Test Report	Safety ³⁾ Characteristic	Sicherheits-Kennzahlen / Safety properties		
					PFD/PFH	T _{mission} = 10a	T _{mission} = 20a
PSSu E F 4DI (312200) PSSu E F 4DI-T (314200)	I/O-Modul, 4 digitale Eingänge, 2 Testtakteausgänge I/O Module, 4 digital Inputs, 2 test pulse outputs	6 / 13	PO81286 R1.0 C1329-00/06 PO104846T R1.0	SIL 3 PL "e" Burner	PFD single input PFD double input PFH single input PFH double input	3,63 x 10 ⁻⁴ 9,06 x 10 ⁻⁶ 9,05 x 10 ⁻⁹ [1/h] 3,02 x 10 ⁻⁹ [1/h]	7,25 x 10 ⁻⁴ 1,85 x 10 ⁻⁵ 9,10 x 10 ⁻⁹ [1/h] 3,10 x 10 ⁻⁹ [1/h]
PSSu E F 2DO 2 (312215) PSSu E F 2DO 2-T (314215)	I/O-Modul, 2 digitale Ausgänge, einpolig, 2 A I/O Module, 2 digital Outputs, single pole, 2 A	5 / 12	PO81286 R1.0 C1329-00/06 PO104846T R1.0	SIL 3 PL "e" Burner	PFD single output PFD double output PFH single output PFH double output	8,10 x 10 ⁻⁶ 8,10 x 10 ⁻⁶ 1,06 x 10 ⁻⁹ [1/h] 1,06 x 10 ⁻⁹ [1/h]	1,66 x 10 ⁻⁵ 1,66 x 10 ⁻⁵ 1,13 x 10 ⁻⁹ [1/h] 1,13 x 10 ⁻⁹ [1/h]
PSSu E F 4DO 0.5 (312210) PSSu E F 4DO 0.5-T (314210)	I/O-Modul, 4 digitale Ausgänge, einpolig, 0,5 A I/O Module, 4 digital Outputs, single pole 0.5 A	5 / 12	PO81286 R1.0 C1329-00/06 PO104846T R1.0	SIL 3 PL "e" Burner	PFD single output PFD double output PFH single output PFH double output	8,10 x 10 ⁻⁶ 8,10 x 10 ⁻⁶ 1,06 x 10 ⁻⁹ [1/h] 1,06 x 10 ⁻⁹ [1/h]	1,66 x 10 ⁻⁵ 1,66 x 10 ⁻⁵ 1,13 x 10 ⁻⁹ [1/h] 1,13 x 10 ⁻⁹ [1/h]
PSSu E F 2DOR 8 (312225) PSSu E F 2DOR 8-T (314225)	I/O-Modul, 2 Relaiskontakte, potentialfrei, 8A I/O Module, 2 Relay contacts, potential free, 8A	8 / 15	PO81286 R1.0 C1329-00/06 PO104846T R1.0	SIL 3 PL "e" Burner	PFD single relais PFD double relais PFH single relais PFH double relais	3,33 x 10 ⁻³ 6,73 x 10 ⁻⁷ 7,60 x 10 ⁻⁸ [1/h] 7,73 x 10 ⁻¹⁰ [1/h]	6,66 x 10 ⁻³ 1,34 x 10 ⁻⁶ 7,60 x 10 ⁻⁸ [1/h] 7,78 x 10 ⁻¹⁰ [1/h]
PSSu E F DI OZ 2 (312220) PSSu E F DI OZ 2-T (314220)	I/O-Modul, 1 digitaler Eingang, 1 digitaler, zweipoliger Ausgang, 2 A I/O Module, 1 digital Input, 1 digital Output, dual pole 2 A	7 / 13	PO81286 R1.0 C1329-00/06 PO104846T R1.0	SIL 3 PL "e" Burner	PFD single input PFD double output PFH single input PFH double output	3,63 x 10 ⁻⁴ 9,62 x 10 ⁻⁶ 9,05 x 10 ⁻⁹ [1/h] 1,27 x 10 ⁻⁹ [1/h]	7,25 x 10 ⁻⁴ 1,98 x 10 ⁻⁵ 9,10 x 10 ⁻⁹ [1/h] 1,37 x 10 ⁻⁹ [1/h]



Rail

5 Koppel-Module / Coupling modules

Typ / Type ¹⁾ (Sach-Nr. / Order No.)	Beschreibung / Description	Version ²⁾ HW / FW	Interner Prüfbericht Internal Test Report	Safety Characteristic ³⁾
PSSu XB F-T (314092)	Basis-Station zur Verlängerung des PSSuniversal-Modulbusses Base station to extend the PSSuniversal module bus	--	PO82834T	Kein Sicherheitbauteil No safety device
PSSu XR F-T (314093)	Remote-Station zur Verlängerung des PSSuniversal-Modulbusses Remote station to extend the PSSuniversal module bus	--	PO82834T	Kein Sicherheitbauteil No safety device

6 Zubehör / Accessories

Typ / Type ¹⁾ (Sach-Nr. / Order No.)	Beschreibung / Description	Version HW / FW	Interner Prüfbericht Internal Test Report	Safety Characteristic ³⁾
PSSu E AI SHT1 (312261) PSSu E AI SHT1-T (314261)	Shunt-Modul zur Erweiterung der AI-Module Shunt modul for AI module expansion	1 / --	PO82834T	Kein Sicherheitbauteil No safety device



Rail

Fußnote / Footnote

1) Typ / Type:

Sach.Nr.: Order No.:	Ergänzbar durch Zeichen im Bereich AA...ZZ und 00...99 / Can be added by Character in range AA...ZZ and 00...99.
-T:	Coated Version mit erweitertem Temperaturbereich / Coated Version with extended temperature range

2) Version:

Die Angaben in der Versionsspalte geben die zugelassene Hardware- (HW) / Fail-Safe-Software- (FW) Kombinationen an. Falls nur eine Nummer angegeben ist, kennzeichnet diese die Baugruppe auch alleine vollständig. Diese Liste führt ausschließlich die Versionsnummern der Baugruppen, die seit der Erstausgabe dieser Liste von der TÜV Product Service geprüft und zertifiziert sind. Für Baugruppen mit Versionsnummern die vor den in der Spalte „Version“ aufgeführten Versionsnummern liegen ist im Einzelfall beim Hersteller anzufragen, welche Prüfungen und Zertifikate gültig sind und die entsprechenden Nachweise einzusehen.

The entry in the version column, shows the allowed hardware (HW) / fail safe software (FW) combinations. If only one number is shown, it describes the entire module. This list includes only the version numbers of the modules tested and certified by TÜV Product Service since the first edition of this list. For modules with earlier version numbers than the numbers in the "version" column, please inquire with the manufacturer about any valid tests and certifications, and view the corresponding verification.

3) Sicherheitsmerkmal / Safety characteristics:

T_{mission}:	Für eine maximale Gebrauchsdauer von 20 Jahren gemäß EN ISO 13849-1. Der Wert gilt auch als Intervall der Wiederholungsprüfungen entsprechend EN 61508-6 und IEC 61511 und als Intervall für den Proof-Test und die Gebrauchsdauer nach EN 62061 For a maximum Mission Time of 20 years according to EN ISO 13849-1. The value is also valid as the interval of the proof test according to EN 61508-6 and IEC 61511 and as the interval for the proof test and the service life according to EN 62061
Cat.:	Maximal erreichbarer Gebrauchskategorie nach EN ISO 13849-1. Maximum achievable usage Category according to EN ISO 13849-1.
PL:	Maximal erreichbarer Leistungsgrad entsprechend EN 13849-1 Maximum obtainable Performance Level according EN 13849-1.
Max. SIL:	Maximal erreichbarer Sicherheitsintegritätsstufe entsprechend EN / IEC 62061 Maximum obtainable Safety Integrity Level according EN / IEC 62061
SIL:	Maximal erreichbarer Sicherheitsintegritätsstufe entsprechend EN 61508-6 und IEC 61511 Maximum obtainable Safety Integrity Level according EN 61508-6 und IEC 61511
PFD:	Wahrscheinlichkeit eines gefährliche Versagens bei Anforderung der Sicherheitsfunktion Probability of Failure on Demand.
PFH_d:	Wahrscheinlichkeit eines gefahrbringenden Ausfalls pro Stunde Probability of a dangerous Failure per Hour



Rail

Die Hardware erfüllt die Anforderungen nach / The Hardware fulfills the requirements of:

All	EN IEC 62061:2021	Sicherheit von Maschinen - Funktionale Sicherheit sicherheitsbezogener elektrischer, elektronischer und programmierbarer elektronischer Steuerungssysteme
	EN ISO 13849-1:2015	Sicherheit von Maschinen - Sicherheitsbezogene Teile von Steuerungen - Teil 1: Allgemeine Gestaltungsleitsätze Safety of machinery - Safety-related parts of control systems - Part 1: General principles for design
	EN 61508-1:2010	Funktionale Sicherheit sicherheitsbezogener elektrischer/elektronischer/programmierbarer elektronischer Systeme Teil 1: Allgemeine Anforderungen Functional safety of electrical/electronic/programmable electronic safety-related systems - Part 1: General requirements
	EN 61508-2:2010	Funktionale Sicherheit sicherheitsbezogener elektrischer/elektronischer/programmierbarer elektronischer Systeme - Teil 2: Anforderungen an sicherheitsbezogene elektrische/elektronische/programmierbare elektronische Systeme Functional safety of electrical/electronic/programmable electronic safety-related systems - Part 2: Requirements for electrical/electronic/programmable electronic safety-related systems
	EN 61508-3:2010	Funktionale Sicherheit sicherheitsbezogener elektrischer/elektronischer/programmierbarer elektronischer Systeme - Teil 3: Anforderungen an Software. Functional safety of electrical/electronic/programmable electronic safety-related systems - Part 3: Software requirements.
	EN 61511-2:2017	Funktionale Sicherheit - PLT-Sicherheitseinrichtungen für die Prozessindustrie - Teil 2: Anleitungen zur Anwendung von IEC 61511-1 (IEC 61511-2) Functional safety - Safety instrumented systems for the process industry sector - Part 2: Guidelines for the application of IEC 61511-1 (IEC 61511-2)
	EN 60204-1:2018	Sicherheit von Maschinen - Elektrische Ausrüstung von Maschinen - Teil 1: Allgemeine Anforderungen Safety of machinery - Electrical equipment of machines - Part 1: General requirements
	EN 61131-2:2007	Speicherprogrammierbare Steuerungen - Teil 2: Betriebsmittelanforderungen und Prüfungen Programmable controllers - Part 2: Equipment requirements and tests

Burner¹	DIN EN 298:2024	Feuerungsautomaten für Brenner und Brennstoffgeräte für gasförmige oder flüssige Brennstoffe Automatic burner control systems for burners and appliances burning gaseous or liquid fuels
	DIN EN 50156-1:2016	Elektrische Ausrüstung von Feuerungsanlagen und zugehörige Einrichtungen Teil 1: Bestimmungen für die Anwendungsplanung und Errichtung Electrical equipment for furnaces and ancillary equipment - Part 1: Requirements for application design and installation
	DIN EN 50156-2:2016 (Clause 4.2.3)	Elektrische Ausrüstung von Feuerungsanlagen und zugehörige Einrichtungen - Teil 2: Bestimmungen für den Entwurf, die Entwicklung und die Baumusterprüfung von Sicherheitsbauteilen und Teilsystemen Electrical equipment for furnaces and ancillary equipment - Part 2: Requirements for design, development and type approval of safety devices and subsystems
	DIN EN 13611:2022	Sicherheits- und Regeleinrichtungen für Brenner und Brennstoffgeräte für gasförmige und/oder flüssige Brennstoffe - Allgemeine Anforderungen Safety and control devices for burners and appliances burning gaseous and/or liquid fuels - General requirements
	DIN EN 1643:2024	Sicherheits-, Regel- und Steuereinrichtungen für Gasbrenner und Gasgeräte - Ventilüberwachungssysteme für automatische Absperrventile Safety and control devices for gas burners and gas burning appliances - Valve proving systems for automatic shut-off valves
	ISO 23550:2018	Sicherheits-, Regel- und Steuereinrichtungen für Gas- und/oder Ölbrenner und Gas- und/oder Ölgeräte - Allgemeine Anforderungen Safety and control devices for gas and/or oil burners and appliance - General requirements
	ISO 23551-4:2018	Sicherheits-, Regel- und Steuereinrichtungen für Gasbrenner und Gasgeräte - Besondere Anforderungen - Teil 4: Ventilüberwachungssysteme für automatische Absperrventile Safety and control devices for gas burners and gas-burning appliances - Particular requirements – Part 4: Valve-proving systems for automatic shut-off valves
	<i>The hardware modules are capable to be used within the scope of the following application standards for safety functions up to class C resp. SIL 3 resp. PL e:</i>	
	DIN EN 267:2021	Automatische Brenner mit Gebläse für flüssige Brennstoffe Forced draught burners for liquid fuels
	DIN EN 676:2023	Gebläsebrenner für gasförmige Brennstoffe Forced draught burners for gaseous fuels
	DIN EN 746-2:2011	Industrielle Thermoprocessinganlagen und dazugehörige Prozesskomponenten - Sicherheitsanforderungen - Teil 2: Feuerungen und Brennstoffführungssysteme (ohne Feststoffe) Industrial thermoprocessing equipment - Part 2: Safety requirements for combustion and fuel handling systems
	DIN EN 12953-7:2002	Großwasserraumkessel - Teil 7: Anforderungen an Feuerungsanlagen für flüssige und gasförmige Brennstoffe für den Kessel Shell boilers - Part 7: Requirements for firing systems for liquid and gaseous fuels for the boiler
	DIN EN 12952-8:2022	Wasserrohrkessel und Anlagenkomponenten - Teil 8: Anforderungen an Feuerungsanlagen für flüssige und gasförmige Brennstoffe für den Kessel Water-tube boilers and auxiliary installations - Part 8: Requirements for firing systems for liquid and gaseous fuels for the boiler
ISO 22967:2010	Automatische Brenner mit Gebläse für gasförmige Brennstoffe Forced draught gas burners	
ISO 22968:2010	Automatische Brenner mit Gebläse für flüssige Brennstoffe Forced draught oil burners	
ISO 13577-2:2023	Industrielle Thermoprocessinganlagen und dazugehörige Prozesskomponenten - Sicherheitsanforderungen - Teil 2: Feuerungen und Brennstoffführungssysteme (ohne Feststoffe) Industrial furnaces and associated processing equipment - Safety - Part 2: Combustion and fuel handling systems	

¹ siehe interner Prüfbericht PO99439T R1.2 / see internal Test Report PO99439T R1.2



Rail

	ISO 13577-4:2022	Industrielle Thermoprossanlagen und dazugehörige Prozesskomponenten - Sicherheitsanforderungen - Teil 4: Schutzsysteme Industrial furnaces and associated processing equipment - Safety - Part 4: Protective systems
	NFPA 85:2019	Boiler and Combustion Systems Hazards Code
	NFPA 86:2019	Standard for Ovens and Furnaces

4) Prüfgrundlage der PSS 4000 - Fail-Safe-Funktionsbausteine / Basis of Test of PSS 4000 - Failsafe function blocks

Für die Prüfung und Zertifizierung der aufgeführten Bausteine, bzgl. der Verarbeitung sicherheitsgerichteter Signale, wurden nachfolgende Normen zusätzlich mit herangezogen, bzw. eingeschränkt.

For test and certifying of the specified components, concerning the processing of safety-related signals, the following additional standards were consulted, respectively restricted:

Norm Standard	Titel der Norm Title of standard	Interner Prüfbericht Internal Test Report
A	EN ISO 13851:2019 Sicherheit von Maschinen - Zweihandschaltungen - Funktionelle Aspekte und Gestaltungsleitsätze Safety of machinery - Two-hand control devices - Principles for design and selection	PO99439T R1.1
B	EN 12622:2009 + A1:2013 Sicherheit von Werkzeugmaschinen – Hydraulische Gesenkbiegepressen Safety of machine tools – Hydraulic press brakes	PO97056T R1.1
C	DIN EN ISO 16092-1:2019 Werkzeugmaschinen-Sicherheit - Pressen - Teil 1: Allgemeine Sicherheitsanforderungen Machine tools safety - Presses - Part 1: General safety requirements	PO97056T R1.0
D	DIN EN ISO 16092-2:2021 Werkzeugmaschinen - Sicherheit von Pressen - Teil 2: Mechanische Pressen Machine tools - Safety for presses - Part 2: Mechanical presses	PO97056T R1.0
E	DIN EN ISO 16092-3:2019 Werkzeugmaschinen-Sicherheit - Pressen - Teil 3: Sicherheitsanforderungen für hydraulische Pressen Machine tools safety - Presses - Part 3: Safety requirements for hydraulic presses	PO97056T R1.0
F	DIN EN ISO 16092-4:2020 Werkzeugmaschinen-Sicherheit - Pressen - Teil 4: Pneumatische Pressen Machine tools safety - Presses - Part 4: Safety requirements for pneumatic presses	PO97056T R1.0
G	EN IEC 61496-1:2020 Sicherheit von Maschinen - Berührungslos wirkende Schutzeinrichtungen - Teil 1: Allgemeine Anforderungen und Prüfungen Safety of machinery - Electro-sensitive protective equipment - Part 1: General requirements and tests	PO99439T R1.1
H	EN ISO 10218-1:2011 EN ISO 10218-2:2011 Industrieroboter – Sicherheitsanforderungen - Teil 1: Roboter - Teil 2: Robotersysteme und Integration Robots and robotic devices – Safety requirements for industrial robots - Part 1: Robots - Part 2: Robot systems and integration	PO99439T R1.1
Eingeschränkt auf / restricted to:		
K	IEC 61508-1:2010 Funktionale Sicherheit sicherheitsbezogener elektrischer/elektronischer/programmierbarer elektronischer Systeme Teil 1: Allgemeine Anforderungen Functional safety of electrical/electronic/programmable electronic safety-related systems - Part 1: General requirements	PO97056T R1.0
	ISO 13849-1:2015 Sicherheit von Maschinen - Sicherheitsbezogene Teile von Steuerungen - Teil 1: Allgemeine Gestaltungsleitsätze Safety of machinery - Safety-related parts of control systems - Part 1: General principles for design	
	EN IEC 62061:2021 Sicherheit von Maschinen - Funktionale Sicherheit sicherheitsbezogener elektrischer, elektronischer und programmierbarer elektronischer Steuerungssysteme Safety of machinery - Functional safety of safety-related electrical, electronic and programmable electronic control systems	



Rail

	EN 61511-1:2017	Funktionale Sicherheit - Sicherheitstechnische Systeme für die Prozessindustrie - Teil 1: Allgemeines, Begriffe, Anforderungen an Systeme, Software und Hardware Functional safety - Safety instrumented systems for the process industry sector - Part 1: Framework, definitions, system, hardware and software requirements	
L	DIN EN 298:2024	Feuerungsautomaten für Brenner und Brennstoffgeräte für gasförmige oder flüssige Brennstoffe Automatic burner control systems for burners and appliances burning gaseous or liquid fuels	PO99439T R1.3
	DIN EN 50156-1:2016 (Clause 10.5.6)	Elektrische Ausrüstung von Feuerungsanlagen und zugehörige Einrichtungen Teil 1: Bestimmungen für die Anwendungsplanung und Errichtung Electrical equipment for furnaces and ancillary equipment - Part 1: Requirements for application design and installation	
	DIN EN 1643:2024	Sicherheits-, Regel- und Steuereinrichtungen für Gasbrenner und Gasgeräte - Ventilüberwachungssysteme für automatische Absperrventile Safety and control devices for gas burners and gas burning appliances - Valve proving systems for automatic shut-off valves	
	ISO 23551-4:2018	Sicherheits-, Regel- und Steuereinrichtungen für Gasbrenner und Gasgeräte - Besondere Anforderungen - Teil 4: Ventilüberwachungssysteme für automatische Absperrventile Safety and control devices for gas burners and gas-burning appliances - Particular requirements – Part 4: Valve-proving systems for automatic shut-off valves	
	DIN EN 267:2021	Automatische Brenner mit Gebläse für flüssige Brennstoffe Forced draught burners for liquid fuels	
	DIN EN 676:2023	Gebläsebrenner für gasförmige Brennstoffe Forced draught burners for gaseous fuels	
	DIN EN 746-2:2011	Industrielle Thermoprozessanlagen und dazugehörige Prozesskomponenten - Sicherheitsanforderungen - Teil 2: Feuerungen und Brennstoffführungssysteme (ohne Feststoffe) Industrial thermoprocessing equipment - Part 2: Safety requirements for combustion and fuel handling systems	
	DIN EN 12953-7:2002	Großwasserraumkessel - Teil 7: Anforderungen an Feuerungsanlagen für flüssige und gasförmige Brennstoffe für den Kessel Shell boilers - Part 7: Requirements for firing systems for liquid and gaseous fuels for the boiler	
	DIN EN 12952-8:2022	Wasserrohrkessel und Anlagenkomponenten - Teil 8: Anforderungen an Feuerungsanlagen für flüssige und gasförmige Brennstoffe für den Kessel Water-tube boilers and auxiliary installations - Part 8: Requirements for firing systems for liquid and gaseous fuels for the boiler	
	ISO 22967:2010	Automatische Brenner mit Gebläse für gasförmige Brennstoffe Forced draught gas burners	
	ISO 22968:2010	Automatische Brenner mit Gebläse für flüssige Brennstoffe Forced draught oil burners	
	ISO 13577-2:2023	Industrielle Thermoprozessanlagen und dazugehörige Prozesskomponenten - Sicherheitsanforderungen - Teil 2: Feuerungen und Brennstoffführungssysteme (ohne Feststoffe) Industrial furnaces and associated processing equipment - Safety - Part 2: Combustion and fuel handling systems	



Rail

NFPA 85:2019	Boiler and Combustion Systems Hazards Code	
NFPA 86:2019	Standard for Ovens and Furnaces	

Anmerkung 1: Die Versionsnummer des Bausteins ist von der verwendeten PSS4000-Plattform und/oder PAS-Version abhängig. Die Angaben in den jeweils zugehörigen Benutzerinformationen der Bausteine sind zu beachten. Das System prüft die Kompatibilität der ausgewählten Bausteine zur verwendeten PSS4000-Plattform bzw. PAS-Version. Die Angabe des Sicherheitsmerkmals bezieht sich auf die interne Verarbeitung der sicherheitsgerichteten Signale in der PSS 4000.

Remark 1: The function block version number depends on the used PSS4000-platform and/or PAS version. The application rules in the manual of the respective function block have to be considered. The system checks the compatibility of the selected function blocks and the used PSS-4000-platform and/or PAS version. Indication of the safety feature refers to the internal processing of the safety-related signals in the PSS 4000.

Anmerkung 2:

Das elektronische Nockenschaltwerk dient zur sicheren Überwachung und Steuerung einer mechanischen Presse, und erfüllt die Anforderungen nach Abschnitt 5.4.7.4 der EN 692.

Das elektronische Nockenschaltwerk setzt sich zusammen aus den Komponenten:

- Softwarebausteine "Elektronisches Nockenschaltwerk" (FS_ShiftPositionRange, FS_PositionToAngle, FS_CamController, siehe Kap. 2.6)
- Softwarebausteine "Sichere Zähler" (FS_AbsoluteEncoder, FS_CounterDual, siehe Kap. 2.6)
- PSS 4000 -Zählermodul für Absolutwertgeber "PSSu E F ABS SSI"
- Zwei, unabhängige, getrennte Absolutwertgeber (SSI)

Die Versionsnummer des Bausteins ist von der verwendeten PSS4000-Plattform und/oder PAS-Version abhängig. Die Angaben in den jeweils zugehörigen Benutzerinformationen der Bausteine sind zu beachten. Das System prüft die Kompatibilität der ausgewählten Bausteine zur verwendeten PSS4000-Plattform bzw. PAS-Version.

Die Angabe des Sicherheitsmerkmals bezieht sich auf die interne Verarbeitung der sicherheitsgerichteten Signale in der PSS 4000.

Remark 2:

The purpose of the electronic cam controller is to monitor and control a mechanical press and fulfills the requirements of section 5.4.7.4 of the EN 692.



The electronic cam controller consists of the components:

- Software blocks "Electronic Cam Controller" (FS_ShiftPositionRange, FS_PositionToAngle, FS_CamController, see section 2.6)
- Software blocks "Safe Counter" (FS_AbsoluteEncoder, FS_CounterDual, see section 2.6)
- PSS 4000 counter module for SSI encoders
- Two independent, separate absolute encoders (SSI)

The function block version number depends on the used PSS4000-platform and/or PAS version. The application rules in the manual of the respective function block have to be considered. The system checks the compatibility of the selected function blocks and the used PSS-4000-platform and/or PAS version. Indication of the safety feature refers to the internal processing of the safety-related signals in the PSS 4000.



Rail

	Freigabe Prüflabor für Sicherheitskomponenten: Release by Testing Laboratory for Safety Components:	Freigabe Zertifizierstelle: Release by Certification Body:
Datum: Date:	Julian Wolf	Thomas Kreten
Unterschrift: Signature:	 2025.12.16 09:51:32 +01'00'	 2025.12.16 09:53:11 +01'00'



Rail

Add value.
Inspire trust.

Report
on the
Certificate
Z10 020132 0247 Rev. 02
and
M6A 020132 0248 Rev. 02
of the
Automation System
PSS 4000 and PSS universal (PSSu)

Applicant

PILZ GmbH & Co. KG
Felix-Wankel-Str. 2
73760 Ostfildern
Germany

Report No.: PO86167C

Version 2.4 of 2025-07-10

Testing Laboratory for Safety Components

TÜV SÜD Rail GmbH
Rail Automation
Westendstraße 199
80686 München

Certification Body

TÜV SÜD Product Service GmbH
Ridlerstraße 65
80686 München

(Page 1 of 22)

This report may be represented only in full wording. The use for promotion needs written permission. This report contains the result of a unique investigation of the product being tested and places no generally valid judgment about characteristics out of the running fabrication. Official translations of this technical report are to be authorised by the test and certification body.

Table of Contents

page

1	Target of Evaluation (ToE)	4
2	Scope of Testing	5
2.1	Test Specimen	5
2.1.1	PSS 4000 System Description.....	5
2.1.1.1	Head module	6
2.1.1.2	I/O Modules	7
2.1.1.3	Supply voltage.....	7
2.1.1.4	Remote units	7
2.1.1.5	Communication	7
2.1.1.5.1	Module bus	7
2.1.1.5.2	SafetyNET p	7
2.1.1.6	System software.....	8
2.1.1.6.1	Software components	8
2.1.1.6.2	Programming environment / project planning	8
2.1.1.6.3	“RUN Time System” firmware	8
2.1.1.6.4	Input/output module firmware	9
2.1.2	PSS universal System Description	9
2.2	Nomenclature and Identification of PSS 4000 and PSS universal (PSSu)	11
3	Certification Requirements	12
3.1	Certification Documentation	13
4	Standards and Guidelines	14
4.1	Functional Safety.....	14
4.2	Application Standards	15
4.3	Electrical Safety	17
4.4	Environmental Testing.....	17
4.5	Electromagnetic Compatibility	18
4.6	Safety Information in the Product Documentation (safety manual, operating instructions, labelling)	18
4.7	Quality Management System	18
5	Results	20
5.1	Functional Safety.....	20
6	Implementation Conditions and Restrictions	21
7	Certificate Number	22

List of Tables

page

Table 1:	Modification history.....	3
Table 2:	HW Identification of PSS 4000 and PSS universal (PSSu).....	11
Table 3:	SW Identification of PSS 4000 and PSS universal (PSSu).....	11
Table 4:	Technical Report.....	13
Table 6:	Basic safety standards.....	14
Table 7:	Associated safety standards.....	14
Table 8:	Application standards.....	17
Table 9:	Electrical safety standards.....	17
Table 10:	Environmental testing standards.....	18
Table 11:	Electromagnetic compatibility standards.....	18
Table 12:	Safety information standards.....	18
Table 13:	Quality Management System.....	19

Modification History

Rev.	Status	Date	Author	Modification / Description
2.0	Replaced	2022-09-20	Peter Weiß	Re-issue of certificate, the report is based on PO86167C V1.3
2.1	Replaced	2023-05-15	Volker Sperling	Modification of release of PSS 4000 – Firmware / PAS 4000 Formal adjustment to template v19
2.2	Replaced	2023-11-03	Dr. Julian Wolf	Update of section 3.1 Update of standards
2.3	Replaced	2024-03-26	Dr. Julian Wolf	Addition of standards /N18/-/N51/
2.4	Active	2025-07-10	Natalia Paredes	New modification PO105048T v1.0

Table 1: Modification history

1 Target of Evaluation (ToE)

In August 2022 PILZ GmbH & Co. KG requested TÜV SÜD Rail GmbH to test and certify the PSS 4000 and PSS universal (PSSu) according to the standard listed in clause 4 of this report. The project numbers related to this Technical Report are 717526139 / 717526155.

In December 2024 the company Pilz GmbH & CO.KG assigned TÜV SÜD for testing and certifying the modification to have an additional supplier for plug-in terminals, pin headers and screw terminals of the PSS 4000 and PSS universal (PSSu) according to the standard listed in clause 4 of this report. The project number related to this Technical Report is 717531569.

The ToE is a product used in safety related applications. The PSS 4000 and PSS universal (PSSu) is an Automation System approved for

- SIL 3 according to IEC 61508
- Maximum SIL 3 according to EN IEC 62061
- PL e, Cat. 4 according to EN ISO 13849-1

2 Scope of Testing

2.1 Test Specimen

This report covers the safety related programmable PSS 4000 and PSS universal (PSSu) systems.

2.1.1 PSS 4000 System Description

The PSS 4000 system is a safety-related programmable system (Safety PLC) that is suitable for risk reduction in safety-related applications in production technology, mechanical engineering and process technology.

Depending on the required function, a device is assembled from various modules to form a PSSu system. The system therefore basically consists of multiple components that can be connected in the way shown below:

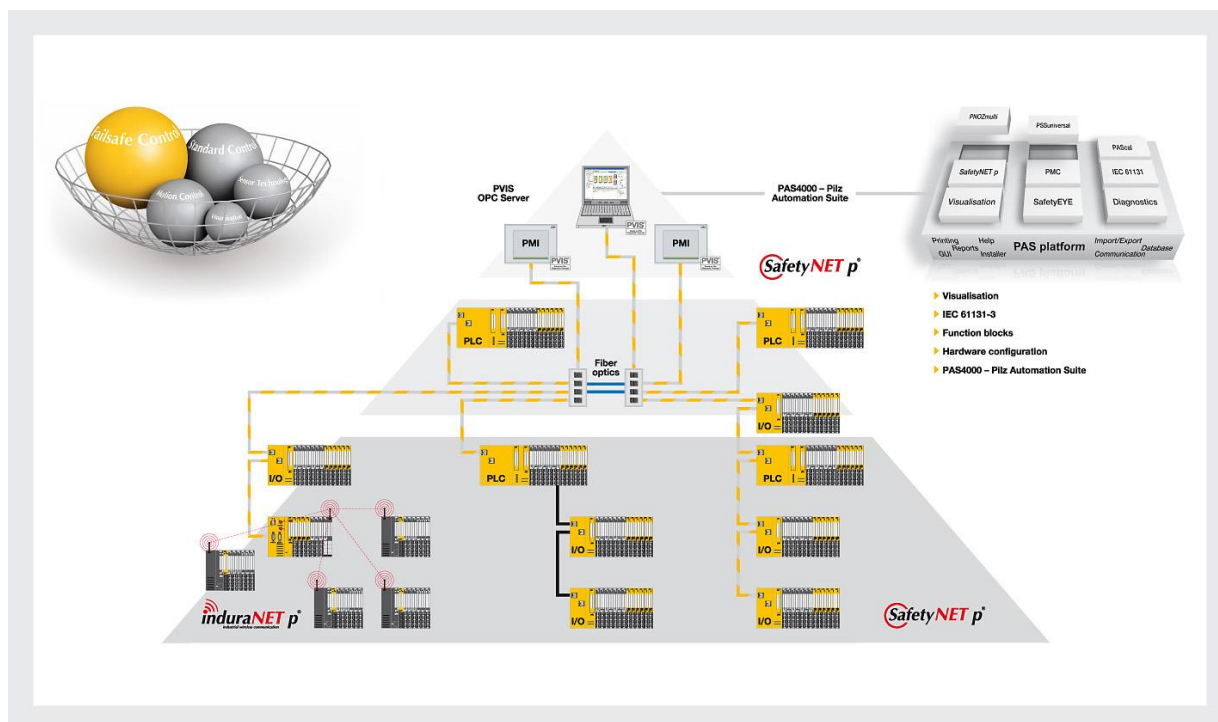

Figure 1: System architecture

The safety PLC in the PSS universal system basically consists of the following modules:

- 1.) Head module – coordinates the data traffic and contains the PLC functionality
- 2.) Input/output modules (2 designs: Compact module or electronic module with base module)
- 3.) Base modules (carrier units for the electronic modules)
- 4.) Compact modules (combination of electronic module and base module)

- 5.) Electronic modules (determine the function of the supply voltage module or input/output module)
- 6.) Supply voltage modules
- 7.) PAS4000 programming environment

Safety-critical input signals are read by means of failsafe peripherals or by other PLCs via safety-related communication channels.

Safety-related output signals are sent by the PLCs to the peripherals or to other CPUs by means of failsafe communication. The peripherals are responsible for switching the failsafe process outputs.

Safety-related communication within a PSSu system is implemented by means of the module bus. The module bus supplies the modules of a PSSu system with voltage and transfers data between the head module and the electronic/compact modules. The module bus is formed by arranging the base modules/compact modules together and connecting them via a mechanical latch.

Safety-related communication within the system is implemented by using the "SafetyNET p" protocol.

Safety-related reaction to detected faults is triggered by the redundantly designed units, which deactivate the outputs by means of a signal, or defined measures are initiated during application processing.

2.1.1.1 Head module

There are currently 3 types of head module:

- 1.) Decentralized PSSu universal I/O system (for further details, see chapter 2.1.1.4 "*Remote units*" and chapter 4 "PSS universal (PSSu)")
- 2.) "PSSu multi" control system with the functionality of a miniature programmable safety system
- 3.) PSSu PLC to control automation systems

All safety-related head modules have a 2-channel diverse microcontroller architecture with mutual diagnostics and independent watchdogs. If failsafe and standard applications are combined, the standard application runs on only one of the two controllers.

2.1.1.2 I/O Modules

The input and output modules are the same for PSS 4000 and PSS universal (PSSu). Technical details can be found in the related technical reports.

2.1.1.3 Supply voltage

The supply voltage modules are the same for PSS 4000 and PSS universal (PSSu). Technical details can be found in the related technical reports.

2.1.1.4 Remote units

Remote units (RIO) are implemented by using head modules without PLC function. The PSSu universal system (see chapter 2.1.2), which has no control functionality but has electronic modules and/or compact modules, is controlled via SafetyNET p by means of a PSSu PLC control system.

2.1.1.5 Communication

2.1.1.5.1 Module bus

The module bus supplies the modules of a PSSu system with voltage and transfers data between the head module and the electronic/compact modules. The module bus is formed by arranging the base modules/compact modules together and connecting them via a mechanical latch. The module bus is structured as follows:

- Data bus
Two separate bus systems for failsafe data (FS module bus) and for standard data (ST module bus).
- Supply voltage
Various supply voltage modules supply voltage for:
 - Module supply
The module supply is the internal supply voltage for the head module and for the electronic/compact modules.
 - Periphery supply
The periphery supply supplies the sensors and actuators on input/output modules. On failsafe modules, the periphery supply can be used to provide test pulses for the outputs. On analogue input/output modules and counter modules, the periphery supply is galvanically isolated from the inputs/outputs.
 - The integrated voltage buses on the module bus can be disconnected in order to form supply groups.

2.1.1.5.2 SafetyNET p

SafetyNET p is used for networked automation tasks. SafetyNET p is an Ethernet-based multi-master bus system suitable for industrial use. The SafetyNET p protocol contains a safe data channel for safety-related data. This channel is certified for data transfer in accordance with SIL 3 of IEC 61508. On SafetyNET p, safety-related and non-safety-related

data is transferred via different data channels, but using the same connection cable. In terms of the topology, SafetyNET p supports the familiar Ethernet architectures, this allows modular system architectures and individual subnetworks to be implemented. If necessary, this method can be used to divide automation functions into decentralised and largely independent function units.

2.1.1.6 System software

2.1.1.6.1 Software components

The software of the PSS 4000 is divided into the following three components:

- PAS4000 (programming environment)
- RUN Time System (firmware) on the head modules
- Firmware for the input/output modules

2.1.1.6.2 Programming environment / project planning

Design, configuration, programming, commissioning and diagnostics take place centrally via PAS4000 (Pilz Automation Suite 4000). PAS4000 is a graphical user interface installed on a PC. Microsoft Win7, WIN8 and Win10 are supported as operating systems.

PAS4000 is a collection of various tools which can be used to create and edit a project, e.g.:

- Device Editor
The Device Editor is used to set up the required hardware configurations (at present this is done based on the PSSu system).
- I/O Mapping Editor
The I/O Mapping Editor is used to set up the connection between the user program and hardware.
- Programming Editor
The Programming Editor is used to program the user program in the selected programming language, e.g. "Instruction List" IL.

The PAS4000 contains multiple so-called safety loops that can detect many faults in the parameterisation and programming process. Plausibility checks and diverse versions of relevant process steps are implemented.

2.1.1.6.3 "RUN Time System" firmware

"RUN Time System" is the firmware of the head module.

The individual subsystems (PLC runtime, I/O systems, SafetyNET p, ...) each have their own cycle. Here, the exchange of the I/O data is decoupled by means of the data broker. Various measures (e.g. sign-of-life monitoring of devices, checking of produced data) are used to detect faults in the distributed systems and to initiate appropriate responses.

Check sums via the FS user program (FS project; code and configuration data) are used to verify the freedom from interference. This is necessary in order to ensure that an already tested and certified FS project does not need to be verified again following a pure ST change.

Various check sums are available to the user:

- a check sum via the ICode of a POU/component block

This check sum can be used in order to fix already tested user code of an individual POU/component block that may need to be reused, for example.

- a check sum via ICode of the entire ST user program and of the entire FS user program (code + configuration)

These check sums can be used to fix the entire, already tested user program (e.g. for acceptance of the system).

The check sums do not change if the hardware platform changes e.g. due to a new processor.

2.1.1.6.4 Input/output module firmware

The firmware for the I/O modules is their operating system.

The input and output modules described in chapter 2.1.2 can also be used with PSS 4000 without need to be changed. They will therefore not be described further here.

2.1.2 PSS universal System Description

The transmission system consists of:

1. Processor of the electronic module
2. Special transceiver from the electronic module to the module bus
3. FS module bus (bus for safe transmission)
4. Special transceiver from the module bus to the head module

The FS module bus is a CAN bus which, deviating from the CAN standard, is not designed as a two-wire line but as a single-wire line.

The head station has three microcontrollers, whereby channel C serves only non-safety-relevant I/O modules. The safety-relevant part is implemented by means of two diversity microcontrollers. Both are connected to the module bus via their internal CAN controller. Both also have a connection to the higher-level SafetyBUS p. Microcontroller A additionally has a connection to the ST module bus, whereby channel C serves the non-safety-relevant modules.

The I/O modules (here only inputs are shown) have a microcontroller which is responsible for operation of the I/Os. All information is read in via the microcontroller and a coder. The coder is switched each cycle via a coding word. The microcontroller does not know the coding algorithm. The head station checks the plausibility between the original data and the coded data.

Additionally, the microcontroller on the module performs the necessary module tests.

The test results are evaluated in the head station.

The figure below shows the subscribers on the module bus.

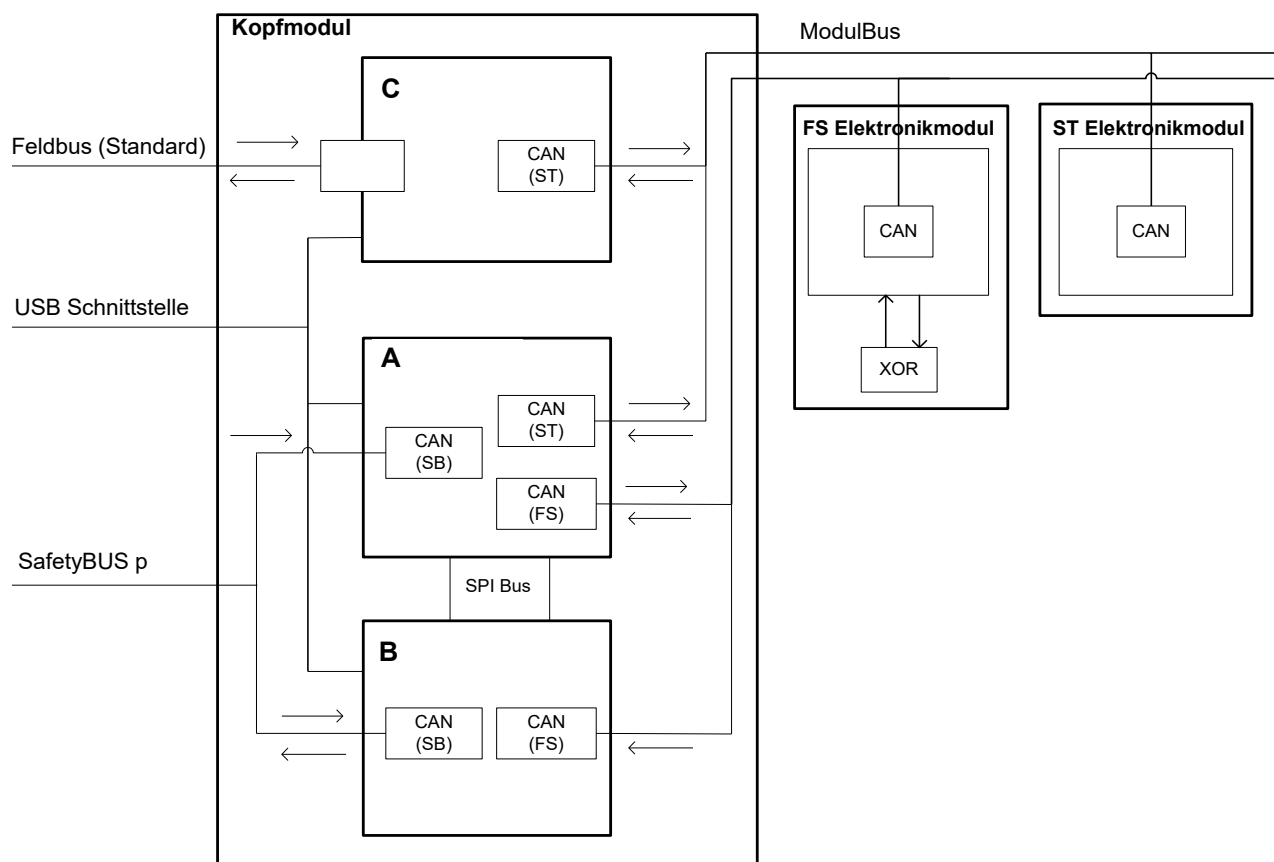

Figure 2: System architecture

2.2 Nomenclature and Identification of PSS 4000 and PSS universal (PSSu)

The PSS 4000 and PSS universal (PSSu) tested is identified by hardware as follows:

Name	Date	HW	Remarks
See actual "List for tracking the version releases of safety related modules of the automation system", PO86101T			

Table 2: HW Identification of PSS 4000 and PSS universal (PSSu)

The PSS 4000 and PSS universal (PSSu) tested is identified by software version as follows:

Name	Date	SW	Remarks
See actual "List for tracking the version releases of safety related modules of the automation system", PO86101T			

Table 3: SW Identification of PSS 4000 and PSS universal (PSSu)

3 Certification Requirements

The certification of the PSS 4000 and PSS universal (PSSu) is according to the regulations and standards listed in clause 4 of this document. This certifies the successful completion of the following test segments.

- I. Functional Safety including
 - Functional safety management (FSM) and safety lifecycle
 - Applied safety development process
 - Analysis of the product structure / architecture (Block-Diagram-FMEA)
 - Analysis of the hardware (FMEDA on component or block level, quantitative analysis)
 - Analysis of the software
 - Verification and validation procedures/activities
 - Fault simulations and software tests
 - Approval of fault avoidance measures
 - Functional tests
- II. Electrical Safety
- III. Susceptibility to environmental errors including
 - Climate and temperature
 - IP degree of protection
 - Mechanical effects
- IV. Electromagnetic compatibility (EMC)
 - Immunity
- V. Safety information in the product documentation (safety manual, user manual, installation and operating instructions).
- VI. Product-Related Quality Assurance in Manufacture and Product Development

3.1 Certification Documentation

The detailed technical evaluation is documented in the most recent version of the Technical Report:

Document No.	Description	Project No.
PO99439T	Technical Report	717526139 / 717526155
PO105048T	Technical Report of Modifications	717531569
Safety related requirements, conditions and restrictions can be found in the following user documentation		
1001468-DE-26	Sicherheitshandbuch	717527554
1001467-DE-31	Systembeschreibung	717527554
21262-DE-07	Installationsrichtlinie	717526139

Table 4: Technical Report

Modifications have been evaluated and tested and are documented in the most recent version of the Technical Report of Modifications (TRM), see actual “List for tracking the version releases of safety related modules of the automation system”, PO86101T.

Based on the specified purpose of use of the PSS 4000 and PSS universal (PSSu) in safety critical process applications, the certification is based on the set of standards listed in clause 4 of this document. The issuance of the certificate states compliance with these references unless specifically noted otherwise.

4 Standards and Guidelines

The regulations and guidelines which form the basis of the type testing are listed below.

4.1 Functional Safety

No.	Reference	Description
/N1/	EN 61508-1:2010	Functional safety of electrical/electronic/programmable electronic safety-related systems – Part 1: General requirements
/N2/	EN 61508-2:2010	Functional safety of electrical/electronic/programmable electronic safety-related systems – Part 2: Requirements for electrical/electronic/ programmable electronic safety-related systems
/N3/	EN 61508-3:2010	Functional safety of electrical/electronic/programmable electronic safety-related systems – Part 3: Software requirements
/N4/	EN IEC 62061:2021	Safety of machinery - Functional safety of safety-related control systems
/N5/	EN ISO 13849-1:2015	Safety of machinery - Safety-related parts of control systems Part 1: General principles for design

Table 5: Basic safety standards

No.	Reference	Description
/N6/	EN 61511-1:2017	Functional safety - Safety instrumented systems for the process industry sector - Part 1: Framework, definitions, system, hardware and application programming requirements; Amendment 1
/N7/	EN 60204-1:2018	Safety of machinery - Electrical equipment of machines - Part 1: General requirements
/N8/	EN 61131-2:2007	Programmable controllers Part 2: Equipment requirements and tests
/N9/	EN IEC 61496-1:2020 ¹	Safety of machinery - Electro-sensitive protective equipment - Part 1: General requirements and tests
/N10/	EN ISO 13851:2019	Safety of machinery - Two-hand control devices - Principles for design and selection

Table 6: Associated safety standards

¹ Only applicable to one component, see PO86101T (List for tracking the version releases of safety related modules of the automation system PSS 4000 and PSS universal (PSSu)).

4.2 Application Standards

Because of the expected applications of the system the following additional standards and regulations were considered. These standards require a final approval of the specific application. The assessment of the PSS 4000 and PSS universal (PSSu) has been performed against the parts of the standard applicable.

No.	Reference	Description
/N11/	EN ISO 16092-1:2018	Machine tools safety - Presses – Part 1: General safety requirements
/N12/	EN ISO 16092-2:2020	Machine tools safety - Presses – Part 2: Safety requirement for mechanical presses
/N13/	EN ISO 16092-3:2018	Machine tools safety - Presses – Part 3: Safety requirements for hydraulic presses
/N14/	EN ISO 16092-4:2020	Machine tools safety - Presses – Part 4: Safety requirements for pneumatic presses
/N15/	EN 13243:2015	Safety requirements for cableway installations designed to carry persons – Electrical equipment other than for drive systems
/N16/	743.121.1: 2004	Verordnung über die Sicherheitsanforderungen an Umlaufbahnen mit kuppelbaren Klemmen (Umlaufbahnverordnung)
/N17/	743.121.3: 2004	Verordnung über die Sicherheitsanforderungen an Pendelbahnen (Pendelbahnverordnung)
/N18/	EN 10218-1:2012	Robots and robotic devices - Safety requirements for industrial robots - Part 1: Robots
/N19/	EN 10218-2:2012	Robots and robotic devices — Safety requirements for industrial robots — Part 2: Robot systems and integration
Burner Systems (approved by TÜV SÜD Industrie Service)		
/N20/	DIN EN 298:2024	Feuerungsautomaten für Brenner und Brennstoffgeräte für gasförmige oder flüssige Brennstoffe
/N21/	DIN EN 50156-1:2016	Elektrische Ausrüstung von Feuerungsanlagen und zugehörige Einrichtungen – Teil 1: Bestimmungen für die Anwendungsplanung und Errichtung
/N22/	DIN EN 50156-2:2016 (Clause 4.2.3)	Elektrische Ausrüstung von Feuerungsanlagen und zugehörige Einrichtungen – Teil 2: Bestimmungen für den Entwurf, die Entwicklung und die Baumusterprüfung von Sicherheitsbauteilen und Teilsystemen
/N23/	DIN EN 13611:2022	Sicherheits- und Regeleinrichtungen für Brenner und Brennstoffgeräte für gasförmige und/oder flüssige Brennstoffe - Allgemeine Anforderungen

No.	Reference	Description
/N24/	DIN EN 1643:2024	Sicherheits-, Regel- und Steuereinrichtungen für Gasbrenner und Gasgeräte - Ventilüberwachungssysteme für automatische Absperrventile
/N25/	ISO 23550:2018	Safety and control devices for gas and/or oil burners and appliances - General requirements
/N26/	ISO 23551-4:2018	Safety and control devices for gas burners and gas-burning appliances - Particular requirements – Part 4: Valve-proving systems for automatic shut-off valves
The hardware modules in the scope of report “C 1731-00/24” by TÜV SÜD Industrie Service are capable to be used within the scope of the following application standards /N27/-/N37/ for safety functions up to class C resp. SIL 3 resp. PL e:		
/N27/	DIN EN 267:2021	Gebläsebrenner für flüssige Brennstoffe
/N28/	DIN EN 676:2023	Gebläsebrenner für gasförmige Brennstoffe
/N29/	DIN EN 746-2:2011	Industrielle Thermoprozessanlagen und dazugehörige Prozesskomponenten - Sicherheitsanforderungen – Teil 2: Feuerungen und Brennstoffführungssysteme (ohne Feststoffe)
/N30/	DIN EN 12953-7:2002	Großwasserraumkessel – Teil 7: Anforderungen an Feuerungsanlagen für flüssige und gasförmige Brennstoffe für den Kessel
/N31/	DIN EN 12952-8:2022	Wasserrohrkessel und Anlagenkomponenten – Teil 8: Anforderungen an Feuerungsanlagen für flüssige und gasförmige Brennstoffe für den Kessel
/N32/	ISO 22967:2010	Forced draught gas burners
/N33/	ISO 22968:2010	Forced draught oil burners
/N34/	ISO 13577-2:2023	Industrial furnaces and associated processing equipment - Safety – Part 2: Combustion and fuel handling systems
/N35/	ISO 13577-4:2022	Industrial furnaces and associated processing equipment - Safety – Part 4: Protective systems
/N36/	NFPA 85:2019	Boiler and Combustion Systems Hazards Code
/N37/	NFPA 86:2019	Standard for Ovens and Furnaces
The failsafe software function blocks in the scope of report “C 1295-03/24” by TÜV SÜD Industrie Service are capable to be used within the scope of the following application standards /N38/-/N51/ for safety functions up to class C resp. SIL 3 resp. PL e:		
/N38/	DIN EN 298:2024	Feuerungsautomaten für Brenner und Brennstoffgeräte für gasförmige oder flüssige Brennstoffe
/N39/	DIN EN 50156-1:2016 (Clause 10.5.6)	Elektrische Ausrüstung von Feuerungsanlagen und zugehörige Einrichtungen – Teil 1: Bestimmungen für die Anwendungsplanung und Errichtung

No.	Reference	Description
/N40/	DIN EN 1643:2024	Sicherheits-, Regel- und Steuereinrichtungen für Gasbrenner und Gasgeräte - Ventilüberwachungssysteme für automatische Absperrventile
/N41/	ISO 23551-4:2018	Safety and control devices for gas burners and gas-burning appliances - Particular requirements – Part 4: Valve-proving systems for automatic shut-off valves
/N42/	DIN EN 267:2021	Gebläsebrenner für flüssige Brennstoffe
/N43/	DIN EN 676:2023	Gebläsebrenner für gasförmige Brennstoffe
/N44/	DIN EN 746-2:2011	Industrielle Thermoprozessanlagen und dazugehörige Prozesskomponenten - Sicherheitsanforderungen – Teil 2: Feuerungen und Brennstoffführungssysteme (ohne Feststoffe)
/N45/	DIN EN 12953-7:2002	Großwasserraumkessel – Teil 7: Anforderungen an Feuerungsanlagen für flüssige und gasförmige Brennstoffe für den Kessel
/N46/	DIN EN 12952-8:2022	Wasserrohrkessel und Anlagenkomponenten – Teil 8: Anforderungen an Feuerungsanlagen für flüssige und gasförmige Brennstoffe für den Kessel
/N47/	ISO 22967:2010	Forced draught gas burners
/N48/	ISO 22968:2010	Forced draught oil burners
/N49/	ISO 13577-2:2023	Industrial furnaces and associated processing equipment - Safety – Part 2: Combustion and fuel handling systems
/N50/	NFPA 85:2019	Boiler and Combustion Systems Hazards Code
/N51/	NFPA 86:2019	Standard for Ovens and Furnaces

Table 7: Application standards

4.3 Electrical Safety

Remark: The following standards were approved by other testing services.

No.	Reference	Description
/N52/	EN 61131-2:2007	Programmable controllers Part 2: Equipment requirements and tests
/N53/	IEC 60204-1:2016 + AMD1:2021	Safety of machinery - Electrical equipment of machines – Part 1: General requirements

Table 8: Electrical safety standards

4.4 Environmental Testing

Remark: The following standards were approved by other testing services.

No.	Reference	Description
/N54/	EN 61131-2:2007	Programmable controllers Part 2: Equipment requirements and tests

Table 9: Environmental testing standards

4.5 Electromagnetic Compatibility

Remark: The following standards were approved by other testing services.

No.	Reference	Description
/N55/	EN 61131-2:2007	Programmable controllers Part 2: Equipment requirements and tests
/N56/	EN 61326-3-1:2017	Electrical equipment for measurement, control and laboratory use - EMC requirements - Part 3-1: Immunity requirements for safety-related systems and for equipment intended to perform safety related functions

Table 10: Electromagnetic compatibility standards

4.6 Safety Information in the Product Documentation (safety manual, operating instructions, labelling)

No.	Reference	Description
/N57/	EN 61508-2:2010	Functional safety of electrical/electronic/programmable electronic safety-related systems – Part 2: Requirements for electrical/electronic/ programmable electronic safety-related systems
/N58/	EN ISO 13849-1:2016	Safety of machinery - Safety-related parts of control systems Part 1: General principles for design
/N59/	IEC 62061:2021	Safety of machinery - Functional safety of safety-related control systems

Table 11: Safety information standards

4.7 Quality Management System

No.	Reference	Description
[M1]	QMS	Quality Management System TÜV SÜD Rail GmbH



Rail

No.	Reference	Description
	TR_RA_P_04.50	Test Program Functional Safety TR_RA_P_04.51 Definition Scope of testing TR_RA_P_04.07 Product Modification TR_RA_P_04.52 Concept Phase & Safety Lifecycle TR_RA_P_04.53 Detail Phase Hardware TR_RA_P_04.54 Detail Phase Software TR_RA_P_04.55 Safety Manual TR_RA_P_04.56 Result of Testing
[M2]	D-PL-11190-08-00	DAkKS accreditation according to DIN EN ISO 17025:2018 / EN ISO/IEC 17025:2017

Table 12: Quality Management System

5 Results

5.1 Functional Safety

The tests performed and quality assurance measures implemented by the PILZ GmbH & Co. KG have shown that the PSS 4000 and PSS universal (PSSu) complies with the testing criteria specified in clause 4 subject to the conditions defined in clause 6 and is suitable for safety-related use in applications up to

- SIL 3 in accordance with IEC 61508 and
- Maximum SIL 3 according to EN IEC 62061 and
- Category 4, PL e according to EN ISO 13849-1.

6 Implementation Conditions and Restrictions

The products of the PSS 4000 system must be used in accordance with the current versions of the product documentation, the safety manuals as well as the requirements and conditions listed below.

- A.1: The operation-related requirements specified in the manuals must be observed.
- A.2: All time requirements and reaction times must be checked during acceptance of an application.
- A.3: All changes in the project (user program and I/O mapping) made after initial commissioning require repeat checking of the application. Testing during recommissioning can be restricted to changes if a revision comparison shows that the modifications affect only a certain part of the program.
- A.4: Before commissioning, a complete function test must be performed on all safety-relevant programmed user functions. During programming of the application, it must be ensured that the modules remain small and manageable so that a complete function test is possible.
- A.5: Online changes in the project (user program and I/O mapping) are solely the responsibility of the user.
- A.6: The overwriting of logical data (“forcing”) must be limited in terms of duration and quantity and is solely the responsibility of the user.

The PSS 4000 system is a safety-related product. For this reason, the recommendations based on the experience and assessments of the manufacturer PILZ GmbH & Co. KG which are documented in the manuals must be carefully considered. The information, recommendations, specifications and the safety instructions given in the respective manuals should be read and understood.

7 Certificate Number

This report specifies technical details and implementation conditions required for the application of PSS 4000 and PSS universal (PSSu) to the certificate:

Z10 020132 0247 Rev. 02

M6A 020132 0248 Rev. 02

Technical Certifier

Christian
Dirmeier

 2025.07.21
09:10:47
+02'00'