

PNOZ Ex



Safety relays

Operating Manual-22222-08

This document is the original document.

All rights to this documentation are reserved by Pilz GmbH & Co. KG. Copies may be made for the user's internal purposes. Suggestions and comments for improving this documentation will be gratefully received.

Source code from third-party manufacturers or open source software has been used for some components. The relevant licence information is available on the Internet on the Pilz homepage.

Pilz®, PIT®, PMI®, PNOZ®, Primo®, PSEN®, PSS®, PVIS®, SafetyBUS p®, SafetyEYE®, SafetyNET p®, the spirit of safety® are registered and protected trademarks of Pilz GmbH & Co. KG in some countries.



SD means Secure Digital

Introduction	5
Validity of documentation	5
Using the documentation	5
Definition of symbols	5
Safety	6
Intended use	6
Safety regulations	7
Safety assessment	7
Use of qualified personnel	7
Warranty and liability	7
Disposal	8
For your safety	8
Unit features	9
Safety features	9
Block diagram/terminal configuration	10
Function Description	10
Operating modes	11
Timing diagram	11
Installation	12
Wiring	12
Preparing for operation	13
Operation	15
Status indicators	15
Faults – Interference	16
Marking	17
Dimensions in mm	17
Technical details	17
Safety characteristic data	28
Supplementary data	29
Service life graph	29

Order reference	30
EC declaration of conformity	30

Introduction

Validity of documentation

This documentation is valid for the product PNOZ Ex. It is valid until new documentation is published.

This operating manual explains the function and operation, describes the installation and provides guidelines on how to connect the product.

Using the documentation

This document is intended for instruction. Only install and commission the product if you have read and understood this document. The document should be retained for future reference.

Definition of symbols

Information that is particularly important is identified as follows:



DANGER!

This warning must be heeded! It warns of a hazardous situation that poses an immediate threat of serious injury and death and indicates preventive measures that can be taken.



WARNING!

This warning must be heeded! It warns of a hazardous situation that could lead to serious injury and death and indicates preventive measures that can be taken.



CAUTION!

This refers to a hazard that can lead to a less serious or minor injury plus material damage, and also provides information on preventive measures that can be taken.



NOTICE

This describes a situation in which the product or devices could be damaged and also provides information on preventive measures that can be taken. It also highlights areas within the text that are of particular importance.

**INFORMATION**

This gives advice on applications and provides information on special features.

Safety**Intended use**

The safety relay PNOZ Ex provides an intrinsically safe output circuit and volt-free contacts for potentially explosive areas in accordance with 2014/34/EU (ATEX) (standards used: EN 60079-0:2012, EN 60079-11:2012 and EN 60079-26:2015 for industrial applications and EN 50303:2000 for use underground).

**WARNING!**

Ignition in a potentially explosive area!

An ignition may cause an explosion which may cause serious injury and death.

- The unit should always be installed outside the potentially explosive area or inside an Ex-protected space.
- Only the intrinsically safe output circuit (terminals S11, S12, S21, S22, S33, S34, S52, Y36, Y37 and GND) and the volt-free contacts (terminals 53-54 and 63-64) may be brought into the potentially explosive area (up to Zone 0 and/or 20).
- Only connect intrinsically safe equipment to the terminals of the intrinsically safe area.

The safety relay PNOZ Ex provides a safety-related interruption of a safety circuit. The safety relay meets the requirements of EN 60947-5-1, EN 60204-1 and VDE 0113-1 and may be used in applications with

- ▶ E-STOP pushbuttons
- ▶ Safety gates

The input circuit must have dual-channel operation.

The following is deemed improper use in particular

- ▶ Any component, technical or electrical modification to the product
- ▶ Use of the product outside the areas described in this manual
- ▶ Use of the product outside the technical details (see [Technical details](#) [ 17]).

**NOTICE**

The unit may only be repaired by Pilz GmbH & Co. KG. Any guarantee is rendered invalid if the housing is opened or unauthorised modifications are carried out.

**NOTICE****EMC-compliant electrical installation**

The product is designed for use in an industrial environment. The product may cause interference if installed in other environments. If installed in other environments, measures should be taken to comply with the applicable standards and directives for the respective installation site with regard to interference.

Safety regulations**Safety assessment**

Before using a device it is necessary to perform a safety assessment in accordance with the Machinery Directive.

Functional safety is guaranteed for the product as a single component. However, this does not guarantee the functional safety of the overall plant/machine. In order to achieve the required safety level for the overall plant/machine, define the safety requirements for the plant/machine and then define how these must be implemented from a technical and organisational standpoint.

Use of qualified personnel

The products may only be assembled, installed, programmed, commissioned, operated, maintained and decommissioned by competent persons.

A competent person is a qualified and knowledgeable person who, because of their training, experience and current professional activity, has the specialist knowledge required. To be able to inspect, assess and operate devices, systems and machines, the person has to be informed of the state of the art and the applicable national, European and international laws, directives and standards.

It is the company's responsibility only to employ personnel who

- ▶ Are familiar with the basic regulations concerning health and safety / accident prevention,
- ▶ Have read and understood the information provided in the section entitled Safety
- ▶ Have a good knowledge of the generic and specialist standards applicable to the specific application.

Warranty and liability

All claims to warranty and liability will be rendered invalid if

- ▶ The product was used contrary to the purpose for which it is intended,
- ▶ Damage can be attributed to not having followed the guidelines in the manual,
- ▶ Operating personnel are not suitably qualified,
- ▶ Any type of modification has been made (e.g. exchanging components on the PCB boards, soldering work etc.).

Disposal

- ▶ In safety-related applications, please comply with the mission time T_M in the safety-related characteristic data.
- ▶ When decommissioning, please comply with local regulations regarding the disposal of electronic devices (e.g. Electrical and Electronic Equipment Act).

For your safety

The unit meets all the necessary conditions for safe operation. However, please note the following:

- ▶ Note for overvoltage category III: If voltages higher than low voltage (>50 VAC or >120 VDC) are present on the unit, connected control elements and sensors must have a rated insulation voltage of at least 250 V.

Unit features

- ▶ Positive-guided relay outputs:
 - 3 safety contacts (N/O), instantaneous in the non-intrinsically safe area
 - 1 instantaneous auxiliary contact (N/C) in the non-intrinsically safe area
- ▶ Relay outputs:
 - 1 instantaneous auxiliary contact (N/O) in the intrinsically safe area
 - 1 instantaneous signal contact (N/O) for blow-out fuse in the intrinsically safe area
- ▶ Connection options for:
 - E-STOP pushbutton
 - Safety gate limit switch
 - Start button
- ▶ LED display for:
 - Supply voltage
 - Input status, channel 1
 - Input status, channel 2
 - Switch state of the safety contacts
 - Protection
 - Error
- ▶ Ex areas:
 - II (1)G [Ex ia Ga] IIB/IIC
 - II (1)D [Ex ia Da] IIIC
 - I (M1) [Ex ia Ma] I
- ▶ Blow-out fuse for short circuit in input circuits (intrinsically safe area)
- ▶ See order reference for unit types

Safety features

The safety relay meets the following safety requirements:

- ▶ The circuit is redundant with built-in self-monitoring.
- ▶ The safety function remains effective in the case of a component failure.
- ▶ The correct opening and closing of the safety function relays is tested automatically in each on-off cycle.

Block diagram/terminal configuration

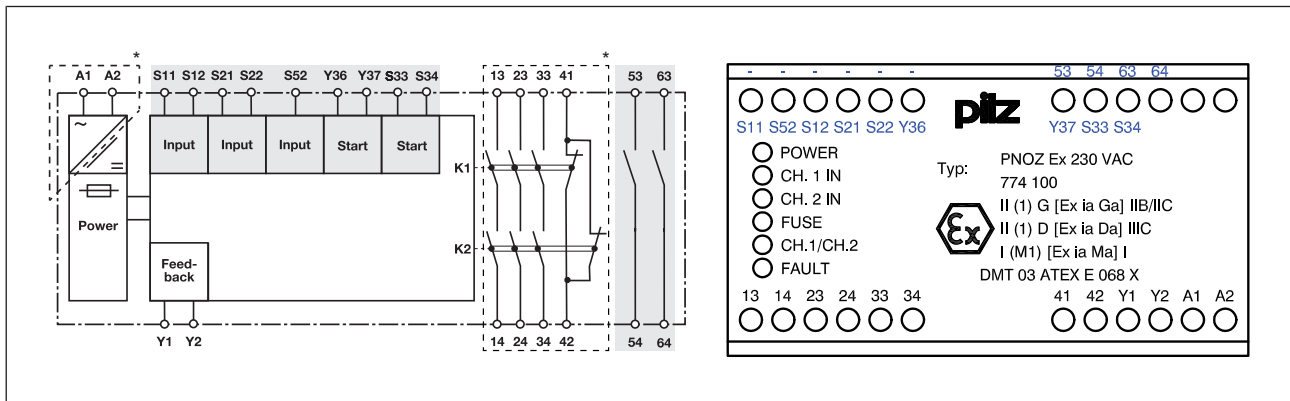

Grey area = intrinsically safe area

*Insulation between the non-marked area and the relay contacts: Basic insulation (over-voltage category III), Protective separation (overvoltage category II)

Function Description

The safety relay PNOZ Ex provides a safety-oriented interruption of a safety circuit. It is divided into an intrinsically safe area and a non-intrinsically safe area. When supply voltage is supplied the "POWER" LED is lit. The unit is ready for operation when the feedback loop Y1-Y2 and the start circuit S12-S34 are closed.

- ▶ Input circuit is closed (e.g. E-STOP pushbutton not operated):
 - The LEDs "CH.1 IN" and "CH.2 IN" are lit.
 - Safety contacts 13-14, 23-24, 33-34 and auxiliary contact 53-54 are closed, auxiliary contact 41-42 is open. The unit is active.
 - The LED "CH.1/CH.2" will light.
- ▶ Input circuit is opened (e.g. E-STOP pushbutton operated):
 - The LEDs "CH.1 IN" and "CH.2 IN" go out.
 - Safety contacts 13-14, 23-24, 33-34 and auxiliary contact 53-54 are opened redundantly, auxiliary contact 41-42 is closed.
 - The LEDs "CH.1" and "CH.2" will light.

The signal contact 63-64 indicates the status of the fuse.

- ▶ Blow-out fuse did not trigger:
 - Signal contact 63-64 is open.
- ▶ Blow-out fuse has blown:
 - Signal contact 63-64 is closed.

Operating modes

- ▶ Dual-channel operation with detection of shorts across contacts: Redundant input circuit, PNOZ Ex detects
 - earth faults in the start and input circuit,
 - short circuits in the input circuit,
 - shorts across contacts in the input circuit.
- ▶ Dual-channel operation without detection of shorts across contacts: Redundant input circuit, detects PNOZ Ex
 - earth faults in the start and input circuit,
 - short circuits in the input circuit.
- ▶ Automatic start: Unit is active once the input circuit has been closed.
- ▶ Manual start: Unit is active once the input circuit and the start circuit are closed.
- ▶ Monitored start: Unit is active once
 - the input circuit is closed and then the start circuit is closed and opened again.
 - the start circuit is closed and then opened again once the input circuit is closed.
- ▶ Increase in the number of available contacts by connecting contact expander modules or external contactors/relays.

Timing diagram

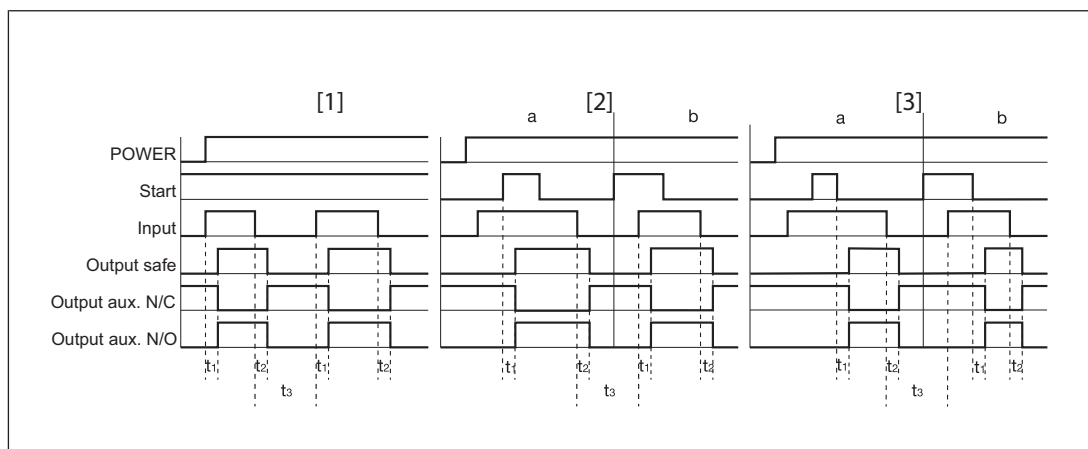

Legend

- ▶ Power: Supply voltage
- ▶ Start: Start circuit
- ▶ Input: Input circuit
- ▶ Output safe: Safety contacts
- ▶ Output aux. N/C: Auxiliary contact, normally closed
- ▶ Output aux. N/O: Auxiliary contact, normally open
- ▶ [1]: Automatic start
- ▶ [2]: Manual start
- ▶ [3]: Monitored start
- ▶ a: Input circuit closes before start circuit

- ▶ b: Start circuit closes before input circuit
- ▶ t_1 : Switch-on delay
- ▶ t_2 : Delay-on de-energisation
- ▶ t_3 : Recovery time

Installation

- ▶ The unit should be installed in a control cabinet with a protection type of at least IP54.
- ▶ Use the notch on the rear of the unit to attach it to a DIN rail (35 mm).
- ▶ When installed vertically: Secure the unit by using a fixing element (e.g. retaining bracket or end angle).



WARNING!

Ignition in a potentially explosive area!

An ignition may cause an explosion which may cause serious injury and death.

- The unit should always be installed outside the potentially explosive area or inside an Ex-protected space.
- Only the intrinsically safe output circuit (terminals S11, S12, S21, S22, S33, S34, S52, Y36, Y37 and GND) and the volt-free contacts (terminals 53-54 and 63-64) may be brought into the potentially explosive area (up to Zone 0 and/or 20).
- Only connect intrinsically safe equipment to the terminals of the intrinsically safe area.

Wiring

Please note:

- ▶ Information given in the "[Technical details \[17\]](#)" must be followed.
- ▶ Ex-protection is only achieved if all work equipment connected to the non-intrinsically safe area is installed outside the potentially explosive area or in an Ex-protected space.
- ▶ Outputs 13-14, 23-24, 33-34 are safety contacts, outputs 41-42, 53-54, 63-64 are auxiliary contacts (e.g. for display).
- ▶ Do **not** use auxiliary contacts 41-42, 53-54, 63-64 for safety circuits!
- ▶ Do not connect undesignated terminals.
- ▶ To prevent contact welding, a fuse should be connected before the output contacts (see [Technical details \[17\]](#)).
- ▶ Calculation of the max. cable length l_{\max} in the input circuit:

$$l_{\max} = \frac{R_{l_{\max}}}{R_l / \text{km}}$$

$R_{l_{\max}}$ = max. overall cable resistance (see [Technical details \[17\]](#))

R_l / km = cable resistance/km

- ▶ Use only shielded cables in the intrinsically safe area.

- ▶ Connect cable shields to the terminals labelled "-".
- ▶ Connectors for external intrinsically safe circuits: Maintain a min. distance of 50 mm between uninsulated parts of the intrinsically safe circuit and uninsulated parts of the non-intrinsically safe circuit, or use a partition to separate them in accordance with EN 60079-11:2012, section 6.2.1.
- ▶ When connecting magnetically operated, reed proximity switches, ensure that the max. peak inrush current (on the input circuit) does not overload the proximity switch.
- ▶ Use copper wire that can withstand 60/75 °C.
- ▶ Do not switch low currents using contacts that have been used previously with high currents.
- ▶ Sufficient fuse protection must be provided on all output contacts with capacitive and inductive loads.
- ▶ Terminals S11, S33 and Y36 are linked internally and either can be used.
- ▶ Ensure the wiring and EMC requirements of EN 60204-1 are met.



WARNING!

Ignition in a potentially explosive area!

An ignition may cause an explosion which may cause serious injury and death.

- Air gaps between uninsulated parts of intrinsically safe circuits and earthed metal parts must be a minimum of 3 mm; air gaps between uninsulated parts of intrinsically safe circuits and uninsulated parts of non-intrinsically safe circuits must at least conform with the values required in Table 5 of EN 60079-11:2012.
- The wiring must meet the requirements in accordance with EN 60079-11:2012 section 6.2 and 6.3.

Preparing for operation

Supply voltage	AC	DC

Input circuit	Dual-channel without detection of shorts across contacts	Dual-channel with detection of shorts across contacts
E-STOP		
Safety gate		
Start circuit	Start from the intrinsically safe area	Start from the non-intrinsically safe area
Automatic start		
Automatic start with start-up test, dual-channel, without detection of shorts across contacts: Simultaneity S1 and S2: 150 ms		
Manual start		
Monitored start		



NOTICE

In the event of an automatic start or manual start with bridged start contact (fault):

The unit starts up automatically when the safeguard is reset, e.g. when the E-STOP pushbutton is released. Use external circuit measures to prevent an unexpected restart.

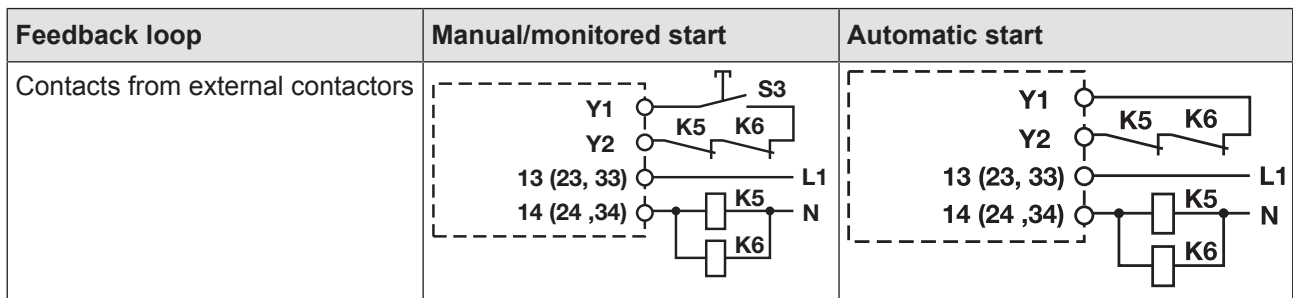

Legend

- ▶ S1/S2: E-STOP/safety gate switch
- ▶ S3: Reset button
- ▶ : Switch operated
- ▶ : Gate open
- ▶ : Gate closed

Operation

When the relay outputs are switched on, the mechanical contact on the relay cannot be tested automatically. Depending on the operational environment, measures to detect the non-opening of switching elements may be required under some circumstances.

When the product is used in accordance with the European Machinery Directive, a check must be carried out to ensure that the safety contacts on the relay outputs open correctly. Open the safety contacts (switch off output) and start the device again, so that the internal diagnostics can check that the safety contacts open correctly

- ▶ for SIL CL 3/PL e at least 1x per month
- ▶ for SIL CL 2/PL d at least 1x per year



NOTICE

The safety function should be checked after initial commissioning and each time the plant/machine is changed. The safety functions may only be checked by qualified personnel.

Status indicators

LEDs indicate the status and errors during operation:



LED on



POWER

Supply voltage is present.



CH.1 IN

Channel 1 input circuit is closed.

**CH.2 IN**

Channel 2 input circuit is closed.

**CH.1/CH.2**

Safety contacts are closed.

**FAULT**

Short circuit: Electronic fuse in the intrinsically safe area has blown.

**FUSE**

Short circuit: Blow-out fuse in the intrinsically safe area has blown. Signal contact 63-64 is closed.

Faults – Interference

- ▶ Earth fault: The supply voltage fails and the safety contacts open. Once the cause of the respective fault has been rectified and the supply voltage is switched off for approx. 1 minute, the unit is ready for operation again.
- ▶ Contact malfunctions: If the contacts have welded, reactivation will not be possible after the input circuit has opened.
- ▶ LED "POWER" does not light: Short circuit or no supply voltage.

Marking

The unit identification is permanently marked on the front and side using tampon/thermal printing. It contains the following Ex-specific details:

- ▶ Certificate number: DMT 03 ATEX E 068 X
- ▶ ATEX categories:
 - II (1)G [Ex ia Ga] IIB/IIC
 - II (1)D [Ex ia Da] IIIC
 - I (M1) [Ex ia Ma] I
- ▶ Manufacturer: Pilz GmbH & Co. KG, 73760 Ostfildern
- ▶ Year of manufacture / production number: Can be identified from the six-digit serial number. Each serial number is assigned a unique parts list including data of manufacture.
- ▶ Temperature range: $-20^{\circ}\text{C} \leq T_a \leq +55^{\circ}\text{C}$
- ▶ CE mark: CE 0123 (no. of accredited body)

Dimensions in mm

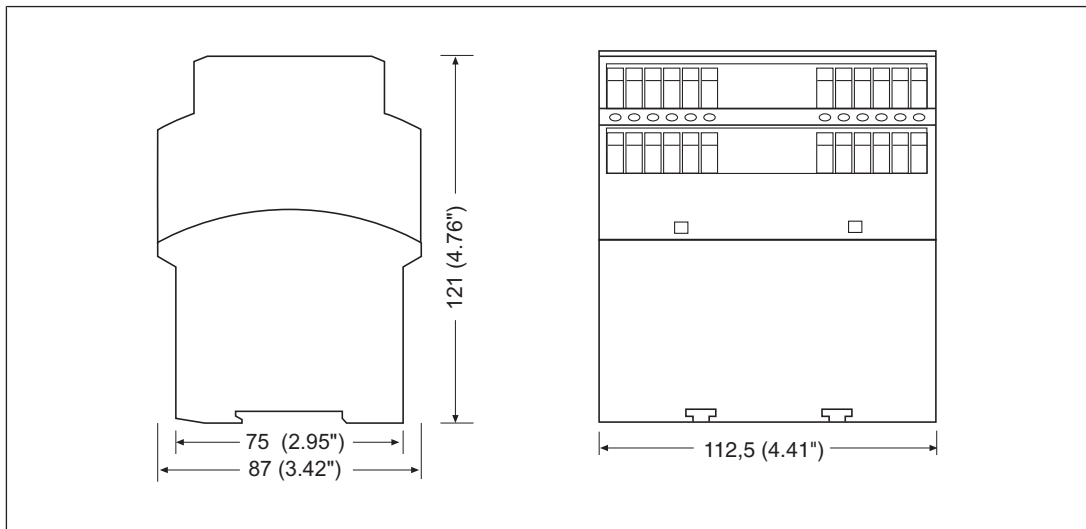

Technical details

Intrinsically safe circuits

- ▶ Intrinsically safe output circuit, connection via terminals S11, S52, S12, S21, S22, Y36, Y37, S33, S34 and 6 terminals GND (-)
 - Ignition protection type/group: [Ex ia] IIB/IIC
 - Output voltage: max. 6.8 VDC - intrinsically safe
 - Output current strength: max. 500 mA
 - Output power: max. 1.7 W
 - trapezoidal output characteristic

- Max. values of external capacitance and inductance:
 [Ex ia] IIC: $C_a=1\mu\text{F}$; $L_a=100\mu\text{H}$
 [Ex ia] I: $C_a=2\mu\text{F}$; $L_a=200\mu\text{H}$
 [Ex ia] IIB: $C_a=2\mu\text{F}$; $L_a=200\mu\text{H}$
 The values IIB also apply for a dust explosion area.
- ▶ Volt-free relay contacts to connect an intrinsically safe circuit (terminals 53 and 54, plus 63 and 64):
 - Switching voltage: max. 30 V DC
 - Switching current strength: max. 500 mA
 - Breaking capacity: max. 10 W

Non-intrinsically safe circuits

- ▶ Non-intrinsically safe supply circuit, connection via terminals A1 and A2

Item no.	Type	Supply voltage
774 101	PNOZ Ex 42 V AC	42 V AC +10 % -15 %
774 104	PNOZ Ex 115 V AC	115 V AC +10 % -15 %
774 105	PNOZ Ex 120 V AC	120 V AC +10 % -15 %
774 100	PNOZ Ex 230 V AC	230 V AC +10 % -15 %
774 099	PNOZ Ex -R 230 V AC	230 V AC +10 % -15 %

- ▶ Ambient temperature range: $-20\text{ }^{\circ}\text{C}$ to $+55\text{ }^{\circ}\text{C}$
- ▶ Protection type: Housing IP40, terminals IP20
- ▶ Non-intrinsically safe output circuit (feedback loop), connection via terminals Y1 and Y2
 - Rated output voltage: 24 VDC
 - Rated output current strength: 20 mA
 - only for connecting a jumper or switch contact
- ▶ Non-intrinsically safe contact circuits, connection via terminals 13 and 14, 23 and 24, 33 and 34, plus 41 and 42
 - Switching capability: AC 240 V/4 A/1000 VA, DC 24 V/2 A/48 W
 - Protection of contact paths: 4 A T

Order no. 774099 – 774101

See below for more order numbers

General	774099	774100	774101
Approvals	ATEX, CCC, CE, EAC (Eurasian), TÜV, cULus Listed	ATEX, CCC, CE, EAC (Eurasian), TÜV, cULus Listed	ATEX, CCC, CE, EAC (Eurasian), TÜV, cULus Listed
Electrical data	774099	774100	774101
Supply voltage			
Voltage	230 V	230 V	42 V
Kind	AC	AC	AC
Voltage tolerance	-15 %/+10 %	-15 %/+10 %	-15 %/+10 %
Output of external power supply (AC)	8 VA	8 VA	8 VA
Frequency range AC	50 - 60 Hz	50 - 60 Hz	50 - 60 Hz
Duty cycle	100 %	100 %	100 %
Inputs	774099	774100	774101
Number	2	2	2
Voltage at			
Input circuit DC	6 V	6 V	6 V
Start circuit DC	6 V	6 V	6 V
Feedback loop DC	24 V	24 V	24 V
Current at			
Input circuit DC	25 mA	25 mA	25 mA
Start circuit DC	15 mA	15 mA	15 mA
Feedback loop DC	20 mA	20 mA	20 mA
Min. input resistance at power-on	324 Ohm	324 Ohm	324 Ohm
Max. overall cable resistance R _{lmax}			
Dual-channel without detection of shorts across contacts at UB AC	80 Ohm	80 Ohm	80 Ohm
Dual-channel with detection of shorts across contacts at UB AC	15 Ohm	15 Ohm	15 Ohm
Max. line capacitance			
EX I/IIIB/IIIC	2 µF	2 µF	2 µF
EX IIC	1 µF	1 µF	1 µF
Max. line inductance			
EX I/IIIB/IIIC	200 µH	200 µH	200 µH
EX IIC	100 µH	100 µH	100 µH

Relay outputs	774099	774100	774101
Number of output contacts			
Safety contacts (N/O), instantaneous	3	3	3
Auxiliary contacts (N/C)	1	1	1
Auxiliary contacts (N/O) intrinsically safe	1	1	1
Signal contacts (N/O) intrinsically safe	1	1	1
Max. short circuit current IK	1 kA	1 kA	1 kA
Utilisation category			
In accordance with the standard	EN 60947-4-1	EN 60947-4-1	EN 60947-4-1
Utilisation category of safety contacts (N/O)			
AC1 at	240 V	240 V	240 V
Min. current	0,01 A	0,01 A	0,01 A
Max. current	4 A	4 A	4 A
Max. power	1000 VA	1000 VA	1000 VA
DC1 at	24 V	24 V	24 V
Min. current	0,01 A	0,01 A	0,01 A
Max. current	2 A	2 A	2 A
Max. power	48 W	48 W	48 W
Utilisation category of auxiliary contacts (N/C)			
AC1 at	240 V	240 V	240 V
Min. current	0,01 A	0,01 A	0,01 A
Max. current	4 A	4 A	4 A
Max. power	1000 VA	1000 VA	1000 VA
DC1 at	24 V	24 V	24 V
Min. current	0,01 A	0,01 A	0,01 A
Max. current	2 A	2 A	2 A
Max. power	48 W	48 W	48 W
Utilisation category auxiliary/signal contacts (N/O) intrinsically safe			
DC1 at	30 V	30 V	30 V
Min. current	0,01 A	0,01 A	0,01 A
Max. current	0,5 A	0,5 A	0,5 A
Max. power	10 W	10 W	10 W
Utilisation category			
In accordance with the standard	EN 60947-5-1	EN 60947-5-1	EN 60947-5-1

Relay outputs	774099	774100	774101
Utilisation category of safety contacts (N/O)			
AC15 at	230 V	230 V	230 V
Max. current	4 A	4 A	4 A
DC13 (6 cycles/min) at	24 V	24 V	24 V
Max. current	2 A	2 A	2 A
Utilisation category of auxiliary contacts (N/C)			
AC15 at	230 V	230 V	230 V
Max. current	4 A	4 A	4 A
DC13 (6 cycles/min) at	24 V	24 V	24 V
Max. current	2 A	2 A	2 A
Utilisation category in accordance with UL			
Voltage	240 V AC G. P.	240 V AC G. P.	240 V AC G. P.
With current	4 A	4 A	4 A
Voltage	24 V DC Resistive	24 V DC Resistive	24 V DC Resistive
With current	2 A	2 A	2 A
Pilot Duty	B300, R300	B300, R300	B300, R300
External contact fuse protection, safety contacts			
In accordance with the standard	EN 60947-5-1	EN 60947-5-1	EN 60947-5-1
Max. melting integral	100 A²s	100 A²s	100 A²s
Blow-out fuse, quick	4 A	4 A	4 A
Blow-out fuse, slow	4 A	4 A	4 A
Blow-out fuse, gG	4 A	4 A	4 A
Circuit breaker 24V AC/DC, characteristic B/C	4 A	4 A	4 A
External contact fuse protection, auxiliary contacts			
Max. melting integral	100 A²s	100 A²s	100 A²s
Blow-out fuse, quick	4 A	4 A	4 A
Blow-out fuse, slow	4 A	4 A	4 A
Blow-out fuse, gG	4 A	4 A	4 A
Circuit breaker 24 V AC/DC, characteristic B/C	4 A	4 A	4 A
Conventional thermal current	4 A	4 A	4 A
Contact material	AgSnO₂ + 0,2 µm Au	AgSnO₂ + 0,2 µm Au	AgSnO₂ + 0,2 µm Au

Times	774099	774100	774101
Switch-on delay			
With automatic start typ.	150 ms	150 ms	150 ms
With automatic start max.	200 ms	200 ms	200 ms
With automatic start after power on typ.	165 ms	165 ms	165 ms
With automatic start after power on max.	210 ms	210 ms	210 ms
With manual start typ.	145 ms	145 ms	145 ms
With manual start max.	200 ms	200 ms	200 ms
With monitored start typ.	115 ms	115 ms	115 ms
With monitored start max.	150 ms	150 ms	150 ms
Delay-on de-energisation			
With E-STOP typ.	10 ms	10 ms	10 ms
With E-STOP max.	30 ms	30 ms	30 ms
With power failure typ.	110 ms	110 ms	110 ms
With power failure max.	150 ms	150 ms	150 ms
Recovery time at max. switching frequency 1/s			
After E-STOP	50 ms	50 ms	50 ms
After power failure	200 ms	200 ms	200 ms
Min. start pulse duration with a monitored start			
	30 ms	30 ms	30 ms
Supply interruption before de-energisation			
	35 ms	35 ms	35 ms
Environmental data	774099	774100	774101
Climatic suitability	EN 60068-2-78	EN 60068-2-78	EN 60068-2-78
Ambient temperature			
Temperature range	-20 - 55 °C	-20 - 55 °C	-20 - 55 °C
Storage temperature			
Temperature range	-40 - 85 °C	-40 - 85 °C	-40 - 85 °C
Climatic suitability			
Humidity	93 % r. h. at 40 °C	93 % r. h. at 40 °C	93 % r. h. at 40 °C
Condensation during operation			
	Not permitted	Not permitted	Not permitted
EMC			
	EN 60947-5-1, EN 61000-6-2, EN 61326-3-1	EN 60947-5-1, EN 61000-6-2, EN 61326-3-1	EN 60947-5-1, EN 61000-6-2, EN 61326-3-1
Vibration			
In accordance with the standard	EN 60068-2-6	EN 60068-2-6	EN 60068-2-6
Frequency	10 - 55 Hz	10 - 55 Hz	10 - 55 Hz
Amplitude	0,35 mm	0,35 mm	0,35 mm

Environmental data	774099	774100	774101
Airgap creepage			
In accordance with the standard	EN 60947-1	EN 60947-1	EN 60947-1
Overvoltage category	III / II	III / II	III / II
Pollution degree	2	2	2
Rated insulation voltage	250 V	250 V	250 V
Rated impulse withstand voltage	4 kV	4 kV	4 kV
Protection type			
Housing	IP40	IP40	IP40
Terminals	IP20	IP20	IP20
Mounting area (e.g. control cabinet)	IP54	IP54	IP54
Mechanical data	774099	774100	774101
Mounting position	Any	Any	Any
Mechanical life	10,000,000 cycles	10,000,000 cycles	10,000,000 cycles
Material			
Bottom	PPO UL 94 V0	PPO UL 94 V0	PPO UL 94 V0
Front	ABS UL 94 V0	ABS UL 94 V0	ABS UL 94 V0
Top	PPO UL 94 V0	PPO UL 94 V0	PPO UL 94 V0
Connection type	Screw terminal	Screw terminal	Screw terminal
Mounting type	Fixed	Fixed	Fixed
Conductor cross section with screw terminals			
1 core flexible	0,2 - 4 mm², 24 - 10 AWG	0,2 - 4 mm², 24 - 10 AWG	0,2 - 4 mm², 24 - 10 AWG
2 core with the same cross section, flexible with crimp connectors, no plastic sleeve	0,2 - 2,5 mm², 24 - 14 AWG	0,2 - 2,5 mm², 24 - 14 AWG	0,2 - 2,5 mm², 24 - 14 AWG
2 core with the same cross section, flexible without crimp connectors or with TWIN crimp connectors	0,2 - 2,5 mm², 24 - 14 AWG	0,2 - 2,5 mm², 24 - 14 AWG	0,2 - 2,5 mm², 24 - 14 AWG
Torque setting with screw terminals	0,6 Nm	0,6 Nm	0,6 Nm
Dimensions			
Height	87 mm	87 mm	87 mm
Width	112,5 mm	112,5 mm	112,5 mm
Depth	121 mm	121 mm	121 mm
Weight	725 g	725 g	725 g

Where standards are undated, the 2017-01 latest editions shall apply.

Order no. 774104 – 774105

General	774104	774105
Approvals	ATEX, CCC, CE, EAC (Eurasian), TÜV, cULus Listed	ATEX, CCC, CE, EAC (Eurasian), TÜV, cULus Listed
Electrical data	774104	774105
Supply voltage		
Voltage	115 V	120 V
Kind	AC	AC
Voltage tolerance	-15 %/+10 %	-15 %/+10 %
Output of external power supply (AC)	8 VA	8 VA
Frequency range AC	50 - 60 Hz	50 - 60 Hz
Duty cycle	100 %	100 %
Inputs	774104	774105
Number	2	2
Voltage at		
Input circuit DC	6 V	6 V
Start circuit DC	6 V	6 V
Feedback loop DC	24 V	24 V
Current at		
Input circuit DC	25 mA	25 mA
Start circuit DC	15 mA	15 mA
Feedback loop DC	20 mA	20 mA
Min. input resistance at power-on	324 Ohm	324 Ohm
Max. overall cable resistance R _{I-max}		
Dual-channel without detection of shorts across contacts at UB AC	80 Ohm	80 Ohm
Dual-channel with detection of shorts across contacts at UB AC	15 Ohm	15 Ohm
Max. line capacitance		
EX I/IIB/IIIC	2 µF	2 µF
EX IIC	1 µF	1 µF
Max. line inductance		
EX I/IIB/IIIC	200 µH	200 µH
EX IIC	100 µH	100 µH
Relay outputs	774104	774105
Number of output contacts		
Safety contacts (N/O), instantaneous	3	3
Auxiliary contacts (N/C)	1	1
Auxiliary contacts (N/O) intrinsically safe	1	1
Signal contacts (N/O) intrinsically safe	1	1

Relay outputs	774104	774105
Max. short circuit current IK	1 kA	1 kA
Utilisation category		
In accordance with the standard	EN 60947-4-1	EN 60947-4-1
Utilisation category of safety contacts (N/O)		
AC1 at	240 V	240 V
Min. current	0,01 A	0,01 A
Max. current	4 A	4 A
Max. power	1000 VA	1000 VA
DC1 at	24 V	24 V
Min. current	0,01 A	0,01 A
Max. current	2 A	2 A
Max. power	48 W	48 W
Utilisation category of auxiliary contacts (N/C)		
AC1 at	240 V	240 V
Min. current	0,01 A	0,01 A
Max. current	4 A	4 A
Max. power	1000 VA	1000 VA
DC1 at	24 V	24 V
Min. current	0,01 A	0,01 A
Max. current	2 A	2 A
Max. power	48 W	48 W
Utilisation category auxiliary/signal contacts (N/O) intrinsically safe		
DC1 at	30 V	30 V
Min. current	0,01 A	0,01 A
Max. current	0,5 A	0,5 A
Max. power	10 W	10 W
Utilisation category		
In accordance with the standard	EN 60947-5-1	EN 60947-5-1
Utilisation category of safety contacts (N/O)		
AC15 at	230 V	230 V
Max. current	4 A	4 A
DC13 (6 cycles/min) at	24 V	24 V
Max. current	2 A	2 A
Utilisation category of auxiliary contacts (N/C)		
AC15 at	230 V	230 V
Max. current	4 A	4 A
DC13 (6 cycles/min) at	24 V	24 V
Max. current	2 A	2 A

Relay outputs	774104	774105
Utilisation category in accordance with UL		
Voltage	240 V AC G. P.	240 V AC G. P.
With current	4 A	4 A
Voltage	24 V DC Resistive	24 V DC Resistive
With current	2 A	2 A
Pilot Duty	B300, R300	B300, R300
External contact fuse protection, safety contacts		
In accordance with the standard	EN 60947-5-1	EN 60947-5-1
Max. melting integral	100 A²s	100 A²s
Blow-out fuse, quick	4 A	4 A
Blow-out fuse, slow	4 A	4 A
Blow-out fuse, gG	4 A	4 A
Circuit breaker 24V AC/DC, characteristic B/C	4 A	4 A
External contact fuse protection, auxiliary contacts		
Max. melting integral	100 A²s	100 A²s
Blow-out fuse, quick	4 A	4 A
Blow-out fuse, slow	4 A	4 A
Blow-out fuse, gG	4 A	4 A
Circuit breaker 24 V AC/DC, characteristic B/C	4 A	4 A
Conventional thermal current	4 A	4 A
Contact material	AgSnO₂ + 0,2 µm Au	AgSnO₂ + 0,2 µm Au
Times	774104	774105
Switch-on delay		
With automatic start typ.	150 ms	150 ms
With automatic start max.	200 ms	200 ms
With automatic start after power on typ.	165 ms	165 ms
With automatic start after power on max.	210 ms	210 ms
With manual start typ.	145 ms	145 ms
With manual start max.	200 ms	200 ms
With monitored start typ.	115 ms	115 ms
With monitored start max.	150 ms	150 ms
Delay-on de-energisation		
With E-STOP typ.	10 ms	10 ms
With E-STOP max.	30 ms	30 ms
With power failure typ.	110 ms	110 ms
With power failure max.	150 ms	150 ms
Recovery time at max. switching frequency 1/s		
After E-STOP	50 ms	50 ms
After power failure	200 ms	200 ms

Times	774104	774105
Min. start pulse duration with a monitored start	30 ms	30 ms
Supply interruption before de-energisation	35 ms	35 ms
Environmental data	774104	774105
Climatic suitability	EN 60068-2-78	EN 60068-2-78
Ambient temperature		
Temperature range	-20 - 55 °C	-20 - 55 °C
Storage temperature		
Temperature range	-40 - 85 °C	-40 - 85 °C
Climatic suitability		
Humidity	93 % r. h. at 40 °C	93 % r. h. at 40 °C
Condensation during operation	Not permitted	Not permitted
EMC	EN 60947-5-1, EN 61000-6-2, EN 61326-3-1	EN 60947-5-1, EN 61000-6-2, EN 61326-3-1
Vibration		
In accordance with the standard	EN 60068-2-6	EN 60068-2-6
Frequency	10 - 55 Hz	10 - 55 Hz
Amplitude	0,35 mm	0,35 mm
Airgap creepage		
In accordance with the standard	EN 60947-1	EN 60947-1
Overvoltage category	III / II	III / II
Pollution degree	2	2
Rated insulation voltage	250 V	250 V
Rated impulse withstand voltage	4 kV	4 kV
Protection type		
Housing	IP40	IP40
Terminals	IP20	IP20
Mounting area (e.g. control cabinet)	IP54	IP54
Mechanical data	774104	774105
Mounting position	Any	Any
Mechanical life	10,000,000 cycles	10,000,000 cycles
Material		
Bottom	PPO UL 94 V0	PPO UL 94 V0
Front	ABS UL 94 V0	ABS UL 94 V0
Top	PPO UL 94 V0	PPO UL 94 V0
Connection type	Screw terminal	Screw terminal
Mounting type	Fixed	Fixed

Mechanical data	774104	774105
Conductor cross section with screw terminals		
1 core flexible	0,2 - 4 mm ² , 24 - 10 AWG	0,2 - 4 mm ² , 24 - 10 AWG
2 core with the same cross section, flexible with crimp connectors, no plastic sleeve	0,2 - 2,5 mm ² , 24 - 14 AWG	0,2 - 2,5 mm ² , 24 - 14 AWG
2 core with the same cross section, flexible without crimp connectors or with TWIN crimp connectors	0,2 - 2,5 mm ² , 24 - 14 AWG	0,2 - 2,5 mm ² , 24 - 14 AWG
Torque setting with screw terminals	0,6 Nm	0,6 Nm
Dimensions		
Height	87 mm	87 mm
Width	112,5 mm	112,5 mm
Depth	121 mm	121 mm
Weight	725 g	725 g

Where standards are undated, the 2017-01 latest editions shall apply.

Safety characteristic data



NOTICE
 You must comply with the safety-related characteristic data in order to achieve the required safety level for your plant/machine.

Operating Mode	EN ISO 13849-1: 2015	EN ISO 13849-1: 2015	EN 62061 SIL CL	EN 62061 PFH _D [1/h]	IEC 61511 SIL	IEC 61511 PFD	EN ISO 13849-1: 2015 T _M [year]
	PL	Category					
–	PL e	Cat. 4	SIL CL 3	3,50E-09	SIL 3	1,23E-05	20

All the units used within a safety function must be considered when calculating the safety characteristic data.



INFORMATION
 A safety function's SIL/PL values are **not** identical to the SIL/PL values of the units that are used and may be different. We recommend that you use the PAscal software tool to calculate the safety function's SIL/PL values.

Supplementary data



CAUTION!

It is essential to consider the relay's service life graphs. The relay outputs' safety-related characteristic data is only valid if the values in the service life graphs are met.

The PFH value depends on the switching frequency and the load on the relay output. If the service life graphs are not accessible, the stated PFH value can be used irrespective of the switching frequency and the load, as the PFH value already considers the relay's B10d value as well as the failure rates of the other components.

Service life graph

The service life graphs indicate the number of cycles from which failures due to wear must be expected. The wear is mainly caused by the electrical load; the mechanical load is negligible.

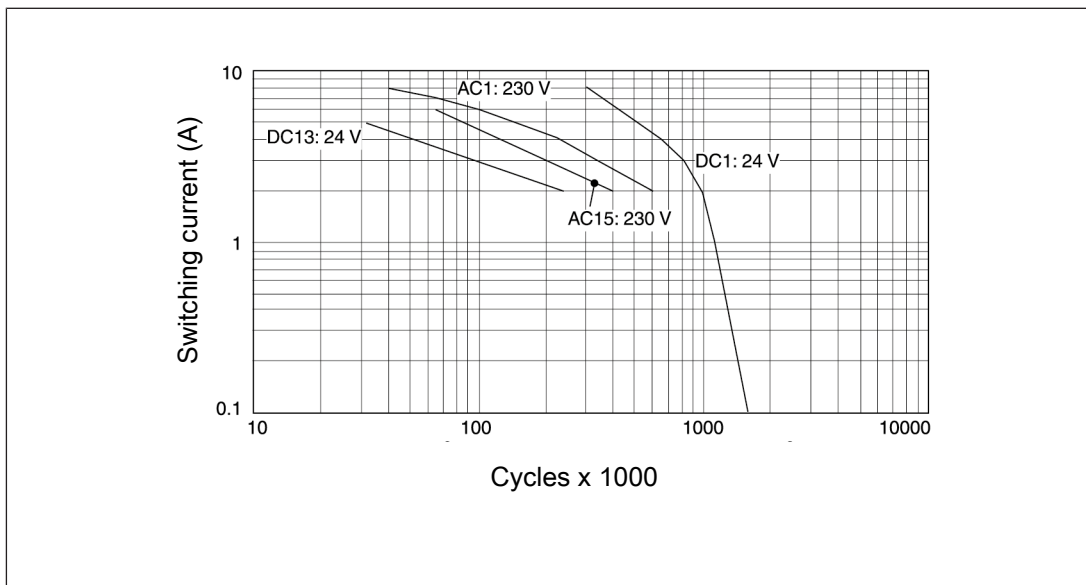

Example

- ▶ Inductive load: 2 A
- ▶ Utilisation category AC15
- ▶ Contact service life: 400 000 cycles

Provided the application to be implemented requires fewer than 400 000 cycles, the PFH value (see Technical details) can be used in the calculation.

To increase the service life, sufficient spark suppression must be provided on all output contacts. With capacitive loads, any power surges that occur must be noted. With DC contacts, use flywheel diodes for spark suppression.

Order reference

Product type	Features	Connection type	Order No.
PNOZ Ex	230 V AC	Screw terminals	774 100
PNOZ Ex	42 V AC	Screw terminals	774 101 *
PNOZ Ex	115 V AC	Screw terminals	774 104
PNOZ Ex	120 V AC	Screw terminals	774 105
PNOZ Ex -R	230 V AC	Screw terminals	774 099 *

* Replacement unit after repair

EC declaration of conformity

This product/these products meet the requirements of the directive 2006/42/EC for machinery and directive 2014/34/EU (ATEX) of the European Parliament and of the Council. The complete EC Declaration of Conformity is available on the Internet at www.pilz.com/downloads.

Authorised representative: Norbert Fröhlich, Pilz GmbH & Co. KG, Felix-Wankel-Str. 2, 73760 Ostfildern, Germany

► Support

Technical support is available from Pilz round the clock.

Americas

Brazil

+55 11 97569-2804

Canada

+1 888-315-PILZ (315-7459)

Mexico

+52 55 5572 1300

USA (toll-free)

+1 877-PILZUSA (745-9872)

Asia

China

+86 21 60880878-216

Japan

+81 45 471-2281

South Korea

+82 31 450 0680

Australia

+61 3 95600621

Europe

Austria

+43 1 7986263-0

Belgium, Luxembourg

+32 9 3217575

France

+33 3 88104000

Germany

+49 711 3409-444

Ireland

+353 21 4804983

Italy, Malta

+39 0362 1826711

Scandinavia

+45 74436332

Spain

+34 938497433

Switzerland

+41 62 88979-30

The Netherlands

+31 347 320477

Turkey

+90 216 5775552

United Kingdom

+44 1536 462203

You can reach our international hotline on:

+49 711 3409-444

support@pilz.com

Pilz develops environmentally-friendly products using ecological materials and energy-saving technologies. Offices and production facilities are ecologically designed, environmentally-aware and energy-saving. So Pilz offers sustainability, plus the security of using energy-efficient products and environmentally-friendly solutions.

Energy
saving by Pilz



Pilz GmbH & Co. KG
Felix-Wankel-Straße 2
73760 Ostfildern, Germany
Tel.: +49 711 3409-0
Fax: +49 711 3409-133
info@pilz.com
www.pilz.com

PILZ
THE SPIRIT OF SAFETY

CMSE®, InduraNET p®, PAS4000®, PASscal®, PASconfig®, Pilz®, PIT®, PLID®, PMCPirotego®, PMCiendo®, PMD®, PMi®, PNOZ®, Pirmo®, PSEN®, PSS®, PVS®, SafetyBUS SafetyEYE®, SafetyNET p®, THE SPIRIT OF SAFETY® are registered and protected trademarks of Pilz GmbH & Co. KG in some countries. We would point out that product features mentioned in the details stated in this document, depending on the status at the time of publication and the scope of the equipment. We accept no responsibility for the validity, accuracy and entirety of the text and graphics presented in this information. Please contact our Technical Support if you have any questions.