



Visualisation; Diagnostics

Easy to Configure

Programming IEC 61131-3

Rapid Installation

PMCprotego S2-2(-C)

PILZ

THE SPIRIT OF SAFETY

► PMCprotego - Safe Motion

This document is the original document.

All rights to this documentation are reserved by Pilz GmbH & Co. KG. Copies may be made for the user's internal purposes. Suggestions and comments for improving this documentation will be gratefully received.

Source code from third-party manufacturers or open source software has been used for some components. The relevant licence information is available on the Internet on the Pilz homepage.

Pilz®, PIT®, PMI®, PNOZ®, Primo®, PSEN®, PSS®, PVIS®, SafetyBUS p®, SafetyEYE®, SafetyNET p®, the spirit of safety® are registered and protected trademarks of Pilz GmbH & Co. KG in some countries.



SD means Secure Digital

1	Introduction	5
1.1	Validity of the documentation.....	5
1.1.1	Retaining the documentation	5
1.2	Definition of symbols	5
2	Overview	7
2.1	Unit structure	7
2.1.1	Unit features	7
2.2	Front view	8
3	Safety	9
3.1	Intended use	9
3.1.1	Permitted motor types	10
3.1.2	Permitted motor encoder types.....	10
3.1.3	Use of qualified personnel	11
3.1.4	Warranty and liability	11
3.1.5	Disposal	12
3.2	Safety assessment	12
3.3	Data backup and data security	12
3.4	Standards	13
4	Function description	14
4.1	Overview	14
4.2	Inputs and outputs	15
4.2.1	Inputs	16
4.2.2	Outputs	17
4.2.2.1	Single-pole outputs	17
4.2.2.2	Output test	18
4.3	Safety functions	20
4.3.1	Safe torque off - STO.....	21
4.3.2	Safe stop 1 - SS1	22
4.3.3	Safe stop 2 - SS2	26
4.3.4	Safe operating stop - SOS	28
4.3.5	Safely limited speed - SLS	31
4.3.6	Safe speed range - SSR	34
4.3.7	Safe direction - SDI	37
4.3.8	Safely Limited Increment - SLI	41
4.4	Operating mode of the servo amplifier	44
4.5	Reaction times	46
4.6	Configuration	47
5	Installation	48
5.1	General requirements	48
5.2	Dimensions	48
5.3	Installing the safety card	49
6	Wiring	50
6.1	General wiring guidelines	50

6.2	Connector pin assignment	51
6.3	Shielding	52
6.4	Digital inputs	53
6.5	Digital outputs	54
6.5.1	Supply voltage	54
6.5.2	Single-pole outputs	55
7	Commissioning	57
7.1	Safety guidelines	57
7.2	Initial commissioning	58
7.3	Recommissioning	61
7.3.1	Recommissioning at a restart	61
7.3.2	Recommissioning after error	62
7.3.2.1	Switching the inputs "SS1 Activate" or "Reset"	63
7.3.2.2	Command "CLRFAULT"	63
7.3.3	Swap safety card	64
7.3.3.1	Download configuration from Configurator to safety card	65
7.3.3.2	Download configuration to SD card	66
7.3.3.3	Download configuration from SD card to safety card	66
7.4	Safety checks	68
8	Operation	70
8.1	Operating states	70
8.2	Testing the safe pulse disabler	71
8.3	Display elements	73
8.4	Messages	74
8.5	Diagnostic tests	74
9	Change, maintenance, decommissioning	75
9.1	Change	75
9.2	Maintenance	76
9.3	Decommissioning	76
10	Technical details	77
10.1	Safety characteristic data	79
10.1.1	Safe actuator with one encoder	79
10.1.1.1	MTTF \geq 10 years	79
11	Order reference	80
	Glossary	81

1 Introduction

1.1 Validity of the documentation

This documentation is valid for the products PMCprotego S2-2 and PMCprotego S2-2-C. It is valid until new documentation is published.

This operating manual explains the function and operation, describes the installation and provides guidelines on how to connect the product PMCprotego S2-2(-C).

Please also refer to the following documents from the motion control range:

- ▶ The configuration of the expansion card is described in the online help for the Configurator PASconfig SDrive.
- ▶ The servo amplifier PMCprotego D is described in the "PMCprotego D operating manual".
- ▶ Details of how to set the parameters for the servo amplifier are described in the help for the commissioning software PASmotion.

You will need to be conversant with the information in these documents in order to fully understand this operating manual.

1.1.1 Retaining the documentation

This documentation is intended for instruction and should be retained for future reference.

1.2 Definition of symbols

Information that is particularly important is identified as follows:



DANGER!

This warning must be heeded! It warns of a hazardous situation that poses an immediate threat of serious injury and death and indicates preventive measures that can be taken.



WARNING!

This warning must be heeded! It warns of a hazardous situation that could lead to serious injury and death and indicates preventive measures that can be taken.



CAUTION!

This refers to a hazard that can lead to a less serious or minor injury plus material damage, and also provides information on preventive measures that can be taken.



NOTICE

This describes a situation in which the product or devices could be damaged and also provides information on preventive measures that can be taken. It also highlights areas within the text that are of particular importance.



INFORMATION

This gives advice on applications and provides information on special features.

2 Overview

2.1 Unit structure

The safety card PMCprotego S2-2(-C) is an expansion of the servo amplifier PMCprotego D. It is used for safe motion monitoring, which is achieved in conjunction with the standard motor encoder and servo amplifier. In the event of an error, the servo amplifier's power element shuts down the power quickly and safely.

2.1.1 Unit features

The safety card has the following features:

2 single-pole digital inputs to activate the safety function Safe Stop 1 (SS1) in accordance with EN 61800-5-2 (fixed assignment):

- ▶ Safety function Safe Stop 1 (SS1)
- ▶ Input to reset the safety card after an error

7 single-pole digital inputs, which can be assigned the following safety functions in accordance with EN 61800-5-2 in the safety card's Configurator:

- ▶ Safe Stop 2 (SS2)
- ▶ Safe Operating Stop (SOS)
- ▶ Safe Speed Range (SSR)
- ▶ Safely Limited Speed (SLS)
- ▶ Safe Direction (SDI)
- ▶ Safely Limited Increment (SLI)

2 single-pole digital outputs with fixed function:

- ▶ Safe Torque Off (STO)
- ▶ Safety card ready (Ready)

4 single-pole digital outputs, which can be freely assigned the status of safety functions.

Supply voltage

- ▶ 24 VDC for digital outputs

LEDs for

- ▶ Supply voltage (POWER)
- ▶ System status (RUN)
- ▶ Download of configuration data (CONFIG)
- ▶ Fault or drive torque-free (STO)

C type:

- ▶ PMCprotego S2-2-C: Coated circuit board

2.2 Front view

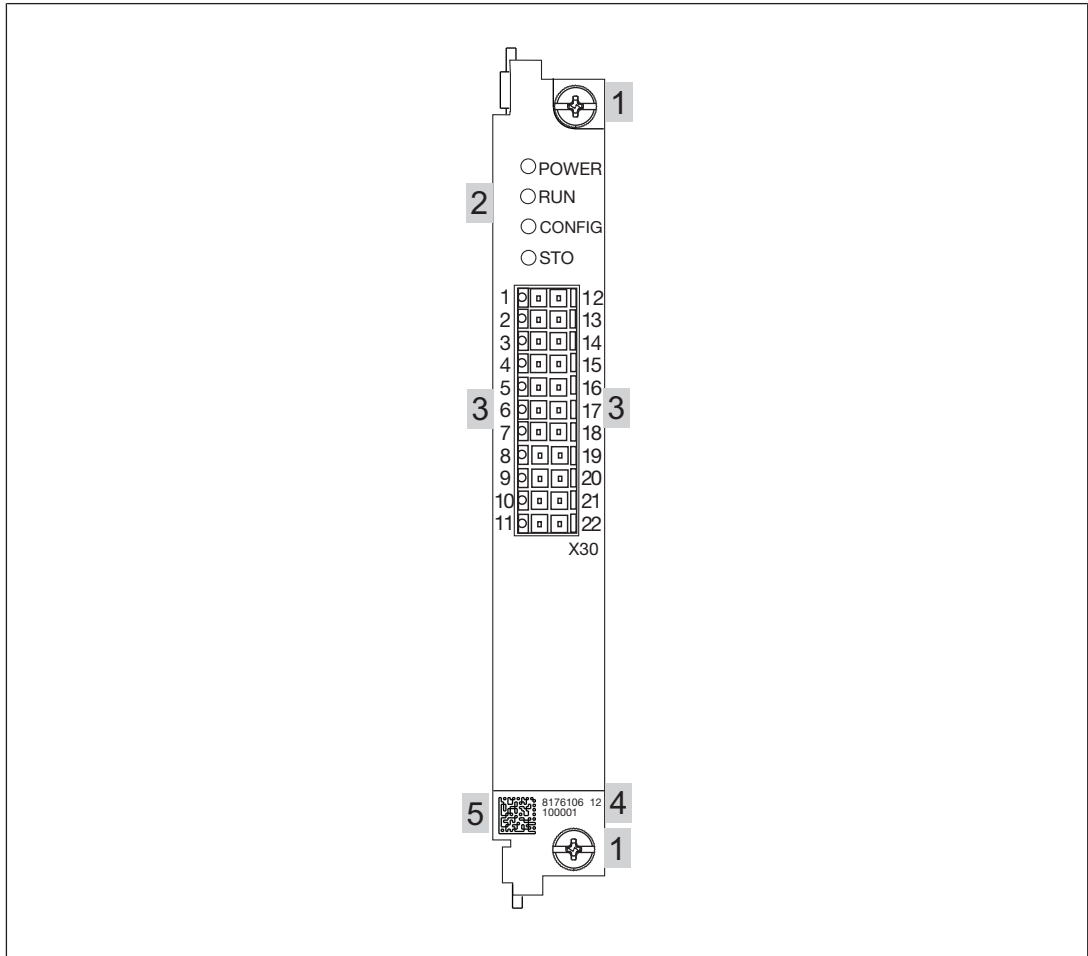

Key:

- ▶ 1: Screw for attachment to the servo amplifier
- ▶ 2: LEDs to display operating states
- ▶ 3: Inputs/outputs and supply voltage
- ▶ 4: Labelling strip with:
 - Order number
 - Serial number
 - Number of device version
- ▶ 5: 2D code

3 Safety

3.1 Intended use

The safety card PMCprotego S2-2(-C) is an expansion of the servo amplifier PMCprotego D. It is designed for use in safety-related applications.

It meets the requirements for safety functions in accordance with EN 61800-5-2, with regard to safe motion monitoring.

The safety card meets the requirements of EN IEC 61508 up to SIL 2 and EN ISO 13849-1 up to PL d.

The function of the safe pulse disabler is tested

- ▶ By restarting after safety functions SS1 or STO have been triggered as a condition of operation
or
- ▶ By restarting after safety function SS1 has been triggered by the operator



INFORMATION

To test the safe pulse disabler through deliberate operator action, see the section entitled "Operation", under "Testing the safe pulse disabler".

The following is deemed improper use

- ▶ Any component, technical or electrical modification to the servo amplifier.
- ▶ Use of the servo amplifier outside the areas described in this manual.
- ▶ Use of the servo amplifier outside the documented technical details (see chapter entitled "Technical Details")

Intended use includes making the installation and wiring EMC-compliant.

Intended use also includes compliance with the

- ▶ Operating manual for the PMCprotego D
- ▶ Online help for the configuration tool PASconfig SDrive.



INFORMATION

For the use of the safety card in a PMCprotego D, the approvals of the relevant servo amplifier apply (see Technical Details in the operating manual of the servo amplifiers).

The safety card PMCprotego S2-2(-C) from Version 1.0 may only be used in conjunction with the following servo amplifiers:

- ▶ PMCprotego D.01 from Version 1.1
- ▶ PMCprotego D.03 from Version 1.1
- ▶ PMCprotego D.06 from Version 1.1
- ▶ PMCprotego D.12 from Version 1.1
- ▶ PMCprotego D.24 from Version 1.1

- ▶ PMCprotego D.48 from Version 1.1
- ▶ PMCprotego D.72 from Version 1.1

3.1.1 Permitted motor types

The following motor types are approved for use with the safety card:

- ▶ Rotary synchronous motors
- ▶ Linear synchronous motors

Please note: The use of synchronous motors without motor encoder (sensorless operation) is not permitted.

Work is in progress for use with:

- ▶ Asynchronous motors

Please note the following fault detection guidelines:

When the drive is operated with an encoder (standard motor encoder on the servo amplifier), a fault on the encoder system is detected by the safety card as follows:

▶ **Rotary synchronous motors**

Detected within one mechanical revolution of the motor.

▶ **Linear synchronous motors**

Detected within the distance travelled, in accordance with the following formula:

$$\text{Distance} = (\text{Number of poles} / 2) \cdot \text{Pole pair pitch}$$

Commands in the servo amplifier:

- Number of poles: MPOLES
- Pole pair pitch: MPITCH

3.1.2 Permitted motor encoder types

The motor encoder is connected to an input on the servo amplifier. The following motor encoder types are approved for use with the safety card:

Encoder type	Feedback type (parameter FBTYPE) in the servo amplifier's commissioning software	Connection to the servo amplifier
Feedback types with one-cable connection (power and feedback in one cable)		
Hiperface DSL	35	X1
SFD3	36	X1
Feedback types with two-cable connection (power and feedback in two cables)		
Resolver	0	X2
Hiperface (Stegmann)	2	X1
EnDat (Heidenhain)	4	X1
SinCos 5 V with W&S	7	X1
RS422 24V	12	X3
ROD 5 V with Hall	15	X1

Encoder type	Feedback type (parameter FBTYPE) in the servo amplifier's commissioning software	Connection to the servo amplifier
ROD 24V with W&S	16	X3
ROD 5V with W&S	17	X1
BiSS encoder 5 V - digital	20	X1
BiSS encoder 12 V - digital	22	X1
BiSS C encoder	33	X1
SSI	25	X1
SSI - Linear encoder	26	X1
ROD 5V	27	X1
EnDat 2.2 with 5 V	32	X1
EnDat 2.2 with 12 V	34	X1

3.1.3 Use of qualified personnel

The products may only be assembled, installed, programmed, commissioned, operated, maintained and decommissioned by persons who are competent to do so.

A competent person is a qualified and knowledgeable person who, because of their training, experience and current professional activity, has the specialist knowledge required. To be able to inspect, assess and operate devices, systems and machines, the person has to be informed of the state of the art and the applicable national, European and international laws, directives and standards.

It is the company's responsibility only to employ personnel who

- ▶ Are familiar with the basic regulations concerning health and safety / accident prevention,
- ▶ Have read and understood the information provided in the section entitled Safety
- ▶ Have a good knowledge of the generic and specialist standards applicable to the specific application.

3.1.4 Warranty and liability

All claims to warranty and liability will be rendered invalid if

- ▶ The product was used contrary to the purpose for which it is intended,
- ▶ Damage can be attributed to not having followed the guidelines in the manual,
- ▶ Operating personnel are not suitably qualified,
- ▶ Any type of modification has been made (e.g. exchanging components on the PCB boards, soldering work etc.).

3.1.5 Disposal

- ▶ In safety-related applications, please comply with the mission time T_M in the safety-related characteristic data.
- ▶ When decommissioning, please comply with local regulations regarding the disposal of electronic devices (e.g. Electrical and Electronic Equipment Act).

3.2 Safety assessment

Before using a device, a safety assessment in accordance with the Machinery Directive is required.

The product as an individual component fulfils the functional safety requirements in accordance with EN ISO 13849 and EN 62061. However, this does not guarantee the functional safety of the overall plant/machine. To achieve the relevant safety level of the overall plant/machine's required safety functions, each safety function needs to be considered separately.

The user is responsible for the safety of the project created in the PASmotion configuration tool. Pay special attention when configuring the project and observe local standards and regulations (see also [Safety tests](#) [ 68]).

3.3 Data backup and data security

Various data security mechanisms are used on the safety card. A distinction is made between technical measures and organisational measures.

Technical measures

Technical measures contribute towards data security with regard to errors and faults. They automatically come into effect as soon as data is exposed to external influences (e.g. errors due to electromagnetic interference). Technical measures include, for example

- ▶ Redundancy when recording and processing safe signals
- ▶ Backup procedure when downloading a project
- ▶ Noise immunity

Organisational measures

Organisational measures contribute towards data security with regard to accidental or intentional data manipulation. The user is primarily responsible for applying appropriate organisational measures.

Organisational measures can mainly be covered with the term "Security". We recommend that you develop a comprehensive strategy with regard to security measures. All criteria that concern the integrity, availability, confidentiality, liability, operational safety and authenticity of data fall under the term "security" (see also the ISO 2700x series of standards).

Security measures include, for example:

- ▶ Authentication
- ▶ Password management
- ▶ Logical and functional division of the office and automation environment on Ethernet-based networks, through firewalls for example
- ▶ Mechanical interlock on unused Ethernet interfaces on the control systems

Data security measures on the configurable safety card PMCprotego S

The safety card has the following technical and organisational measures for data security:

- ▶ Assignment of various access permissions for a configuration in the PASmotion configuration tool
Each project must be assigned 2 passwords. The passwords are used to define access permissions to a different function range (see online help for PASmotion).
- ▶ Detection of different configuration
A check sum (= "check sum safe") is included when a configuration is downloaded. Different configurations can be detected based on this information.
- ▶ Detection of a deviating check sum on the SD memory card of the servo amplifier and in the flash memory when restarting a safety card
- ▶ Detection of an invalid configuration when restarting a safety card
- ▶ Detection of faulty or incompatible configurations when restarting the safety card

3.4 Standards

Knowledge of and compliance with the relevant standards and directives are a prerequisite for using the safety card. The following standards are relevant:

- ▶ EN 61326-3-1: Electrical equipment for measurement, control and laboratory use - EMC requirements
- ▶ EN 61800-3: Adjustable speed electrical drives
- ▶ EN 61800-5-2: Adjustable speed electrical power drive systems – Part 5-2: Safety requirements. Functional
- ▶ EN ISO 13849-1: Safety of machinery – Safety-related parts of control systems – Part 1: General principles for design, Part 2: Safety validation
- ▶ EN 61508: Functional safety of safety-related electrical/electronic/programmable electronic control systems, Parts 1, 3, 4
- ▶ EN 61508-2: Requirements for safety-related electrical/electronic/programmable electronic systems
- ▶ EN 60204-1: Safety of machinery – Electrical equipment of machines – Part 1: General requirements
- ▶ EN 62061: Safety of machinery – Functional safety of safety-related electrical, electronic and programmable electronic control systems

Please note this is not an exhaustive list of safety standards and directives.

Where standards are undated, the 2021-03 latest editions shall apply.

4 Function description

4.1 Overview

The safety card monitors safety functions in accordance with EN 61800-5-2. It monitors safe motion sequences on drives, which are safely brought to a stop and shut down in the event of an error.

The safety card is built into a servo amplifier PMCprotego D. This converts the servo amplifier into a safe servo amplifier.

A **safe drive system** from Pilz consists of the following:

- ▶ Servo amplifier (PMCprotego D)
- ▶ Safety card PMCprotego S built into the servo amplifier
- ▶ Servo motor (synchronous motor) with
 - Standard encoder system (feedback)
 - Brake (optional, not safety-related)
- ▶ Safety control system

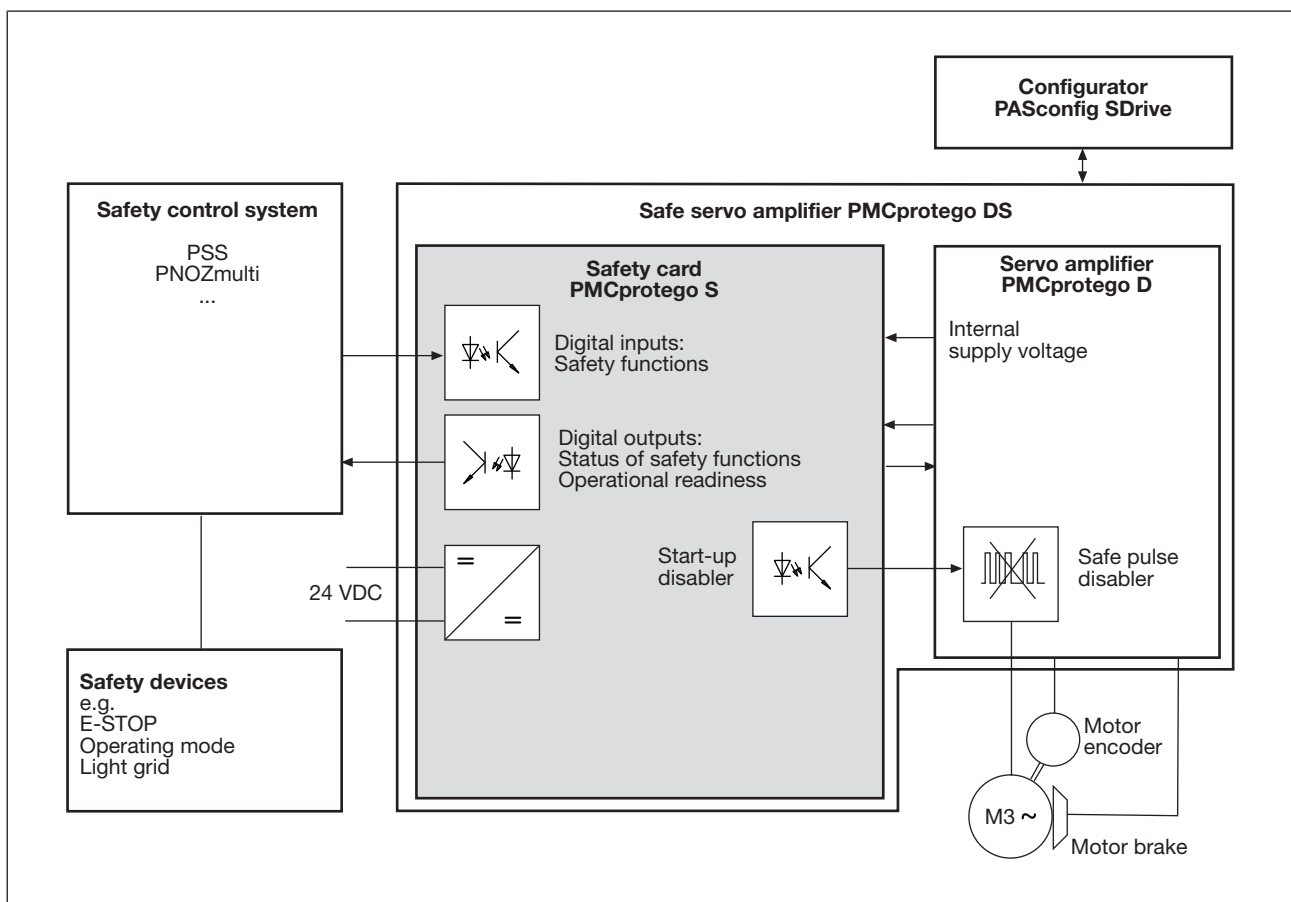

Fig.: Safe drive system

The **safety card**

- ▶ Activates safety functions
- ▶ Monitors safe motion sequences.
- ▶ Signals the status of safety functions to the safety control system
- ▶ In the event of an error, activates the safe pulse disabler which is integrated within the servo amplifier and shuts down the power to the motor
- ▶ Passes the brake command to the servo amplifier that is executing the travel command

The **servo amplifier**

- ▶ Removes the power to the motor, if the safe pulse disabler is activated, switches the motor to torque-free and can also control an internal motor brake.

The **safety control system**

- ▶ Activates the safety functions via inputs on the safety card
- ▶ Evaluates signals from safety devices, such as:
 - E-STOP pushbuttons
 - Safety gates
 - Light beam devices
 - Two-hand buttons
- ▶ Processes the safety card's status outputs
- ▶ Safe interconnection between safety card and safety control system
- ▶ Fault detection (short across contacts, short circuit) on signals between the safety control system and safety card, and initiation of measures

Configurator PASconfig SDrive

- ▶ Configuration and parameterisation of the safety card
- ▶ Safe upload and download of the configuration file
- ▶ Online display of the status of the safety functions
- ▶ Display of error stack
- ▶ Ability to save the configuration to SD card

4.2 **Inputs and outputs**

The safety card has safe inputs and outputs which

- ▶ can be freely assigned
- ▶ can be assigned fixed functions.

Inputs I0 to I6 can be used to activate the safety functions.

Outputs O0 to O3 can be used to acknowledge the status of the safety functions.

Inputs and outputs are assigned to the safety functions in the safety card's Configurator.

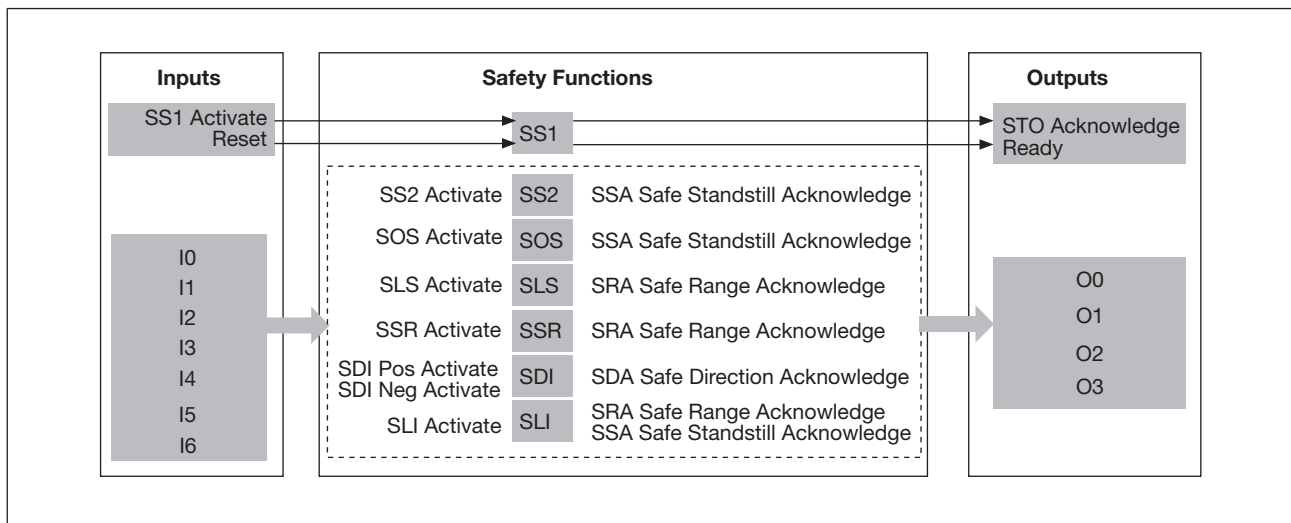

Fig.: Inputs and outputs

4.2.1 Inputs

The safety card has safe single-pole inputs.

Inputs with fixed assignment:

- ▶ **SS1 Activate:** Safe Stop 1
- ▶ **Reset:** Additional safe input to reset the safety card after an error

The single-pole digital inputs I0 ... I6 are used to activate the safety functions. Inputs are assigned to the safety functions in the safety card's Configurator. The following signals are available to activate the safety functions:

- ▶ **SS2 Activate:** Safe Stop 2
- ▶ **SOS Activate:** Safe Operating Stop
- ▶ **SSR Activate:** Safe Speed Range
- ▶ **SLS Activate:** Safely Limited Speed
- ▶ **SDI Neg Activate:** Safe Direction, negative
- ▶ **SDI Pos Activate:** Safe Direction, positive
- ▶ **SLI Activate:** Safely Limited Increment

Signals at the input

- ▶ 1/0 pulse edge at the input: Safety function is triggered
- ▶ "0"-signal (0 V) at the input:
 - Safety function is activated
- ▶ "1"-signal (+24 V) at the input:
 - Safety function is not activated



NOTICE

Inputs "SS1 Activate" and "Reset" must always be connected.

In the case of all inputs, only tested outputs from a safety control system may be connected.

4.2.2 Outputs

4.2.2.1 Single-pole outputs

Safe, single-pole outputs signal the status of the activated safety functions and the safety card's state of readiness.

Outputs with fixed assignment:

▶ **STO Acknowledge**

- 1: Power element switched off
- Internal error on servo amplifier or safety card
- Limit values exceeded
- Activated via SS1
- 0: Drive in closed loop operation

▶ **Ready**

- 1: Safety card is ready for operation
- 0: Safety card is not ready for operation. Possible causes:
 - Safety card is starting up
 - No supply voltage
 - Major internal error
 - Error on the feedback output "STO Acknowledge"



INFORMATION

"Ready" is a second feedback channel for the safety function STO. The "Ready" output switches off if a problem occurs at the feedback signal "STO Acknowledge".

The single-pole digital outputs O0 ... O3 signal the status of the safety functions. Outputs are assigned to the signals in the safety card's Configurator. The following signals are available:

▶ **SSA Safe Standstill Acknowledge**

- 1: Motor is within the permitted limit values for standstill.
- 0: Standstill monitoring is inactive or motor is outside the standstill range

▶ **SDA Safe Direction Acknowledge**

- 1: Drive is moving in the permitted direction.
- 0: Drive is not moving in the permitted direction or monitoring is not activated.

▶ **SRA Safe Range Acknowledge**

- 1: Drive is moving within the permitted limit values for speed or position.
- 0: Drive is moving outside the permitted limit values for speed or position, or monitoring is not activated.

The table below shows which outputs signal the status of which safety function.

Output	In-ternal error	No safety function activated	SS1	SS2	SOS	SLS	SSR	SDI	SLI
STO Acknowledge	x	x	x	x	x	x	x	x	x
SSA Safe Standstill Acknowledge	-	-	-	x	x	-	-	-	x
SDA Safe Direction Acknowledge	-	-	-	-	-	-	-	x	-
SRA Safe Range Acknowledge	-	-	-	-	-	x	x	-	x
Ready	-	x	x	x	x	x	x	x	x

Signals at the output

- ▶ "0"-signal (0 V) at the output:
 - Output is high impedance
 - No current to the load
 - Safety function not activated
- ▶ "1"-signal (+24 V) at the output:
 - Output is low impedance
 - Current is supplied to the load
 - Safety function activated

Supply voltage

- ▶ 24 VDC connection to supply the safety card's digital outputs

4.2.2.2 Output test

The outputs are tested regularly:

- ▶ Outputs that are switched on are checked via regular off tests.
 - Test pulses for outputs that are switched on: see technical details
 - Outputs that are switched on are switched off for the duration of the test pulse.
 - The load must not switch off because of the test.
- ▶ Outputs that are switched off are checked via regular on tests.
 - Test pulses for outputs that are switched off: see technical details
 - Outputs that are switched off are switched on for the duration of the test pulse.
 - The load must not switch on because of the test.

Testing for shorts

- ▶ A test is regularly carried out to check for shorts between the outputs.



WARNING!

When wiring an output with capacitance it is essential to note the pulse duration, repetition period and scan time of the power-up test, otherwise the load may switch on unintentionally.

Timing diagram

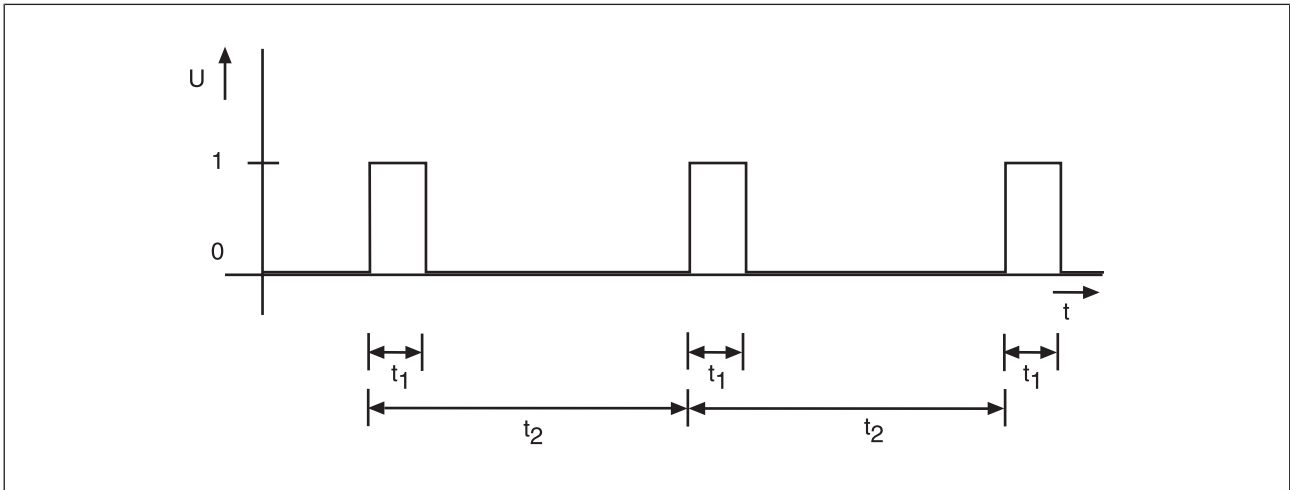

- ▶ 1: "1" signal
- ▶ 0: "0" signal
- ▶ t_1 Pulse duration on on test (see Technical details)
- ▶ t_2 Scan time of power-up test under normal circumstances (ca. 200 ms)

Characteristic: Output capacitance C dependent on load current I

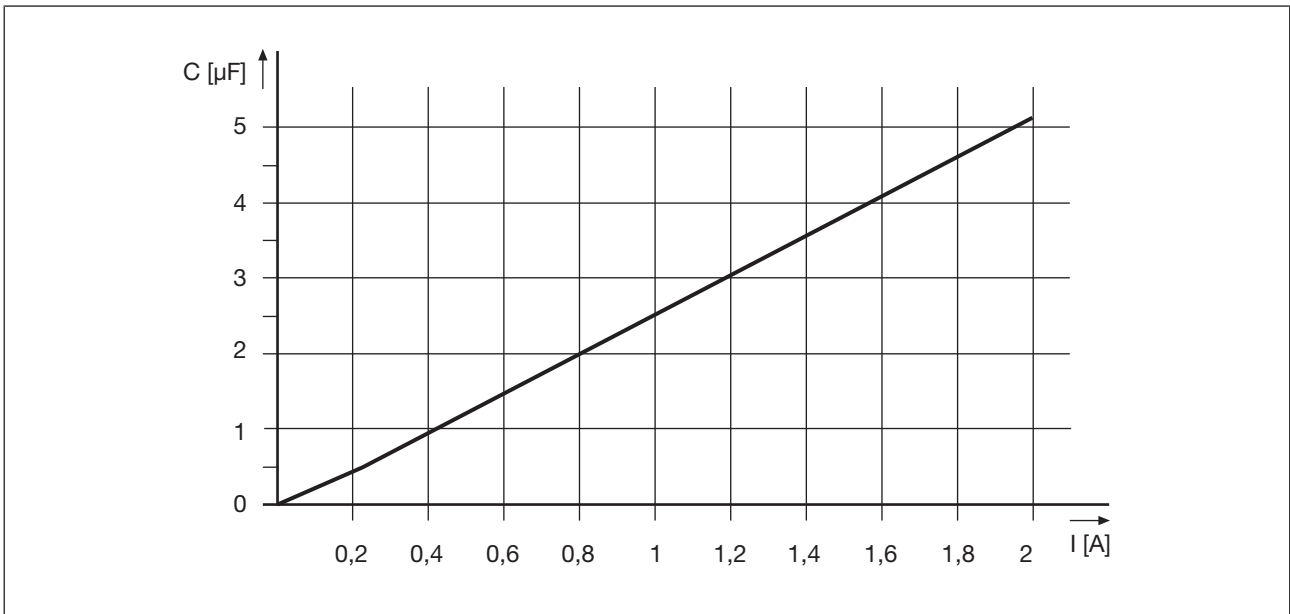

4.3 Safety functions

Safety functions maintain a safe condition on a plant or prevent hazardous conditions arising on a plant.

The safety functions for electrical drives are defined in EN 61800-5-2.

The safety card implements the following safety functions:

- ▶ Safe stop 1 (SS1)
- ▶ Safe stop 2 (SS2)
- ▶ Safe operating stop (SOS)
- ▶ Safe speed range (SSR)
- ▶ Safely limited speed (SLS)
- ▶ Safe direction (SDI)
- ▶ Safely Limited Increment (SLI)

Activation of safety functions

- ▶ The safety functions are activated using the single-pole safe inputs on the safety card.
- ▶ These inputs operate in accordance with the failsafe principle (on switching off). The safety control system activates the safety functions via a 1/0 pulse edge.

Feedback from the safety functions

- ▶ Message via single-pole semiconductor outputs
 - "1" signal: Inside the set limit values
 - "0" signal: Outside the set limit values

Simultaneous activation of safety functions

- ▶ All safety functions can be active at the same time. However, safety function SS1 has priority over all other safety functions.
- ▶ If SS1 is activated, the drive is stopped in accordance with its configuration.
- ▶ No other safety functions are processed or called up during this time.

Reaction to limit value violations and errors

- ▶ When set limit values are exceeded, the E-STOP braking ramp is activated.
- ▶ The safety function STO is activated if there are any internal errors on the safety card or servo amplifier. The power element is switched off.

4.3.1 Safe torque off - STO

The safety function "Safe Torque Off" (STO) removes the power to the motor. It is implemented via the servo amplifier's shutdown path and the safety card's safe outputs.

Features of the safety function:

- ▶ The motor becomes torque-free and no longer generates any hazardous movements.
- ▶ To prevent the drive running down in an uncontrolled manner, in normal operation the safety function STO is activated via the safety function SS1.
- ▶ STO is only activated directly when
 - there is an internal error on the servo amplifier or safety card
 - the STO delay time is set to 0
 - the inputs "SS1 Activate" and "Reset" simultaneously switch to a "0" signal
- ▶ The STO-ENABLE reset lock on the servo amplifier has no function if the servo amplifier contains a safety card. The output contact is linked internally. In this case, the safety card activates the safe pulse disabler on the servo amplifier in order to shut down the power element.
- ▶ The safety function "Safe Torque Off" corresponds to a category 0 stop (uncontrolled stop) in accordance with EN 60204-1.

Prerequisites for normal operation:

- ▶ Input "SS1 Activate" and "Reset": "1" Signal (+24 VDC)
- ▶ "Ready" output: "1" Signal (+24 VDC). The safety card is ready for operation.
- ▶ "STO Acknowledge" output: "0" Signal

Safety function is activated

- ▶ By an error after limit values have been exceeded or
- ▶ By an internal error on the safety card or servo amplifier, if the drive can no longer be braked safely
- ▶ By executing the safety function SS1 (1/0 pulse edge). In this case the drive is braked safely before it is switched to torque-free (see section: "Safe stop – SS1").
- ▶ The inputs "SS1 Activate" and "Reset" simultaneously switch to a "0" signal
- ▶ A second error occurs while SS1 (drive shutdown) is activated.

Reaction:

- ▶ The drive is switched to torque-free
- ▶ "STO Acknowledge" output: "1" Signal

If any external forces influence the motor axis (e.g. suspended loads), additional measures (e.g. a safety holding brake) are required in order to eliminate hazards.

Timing diagram:

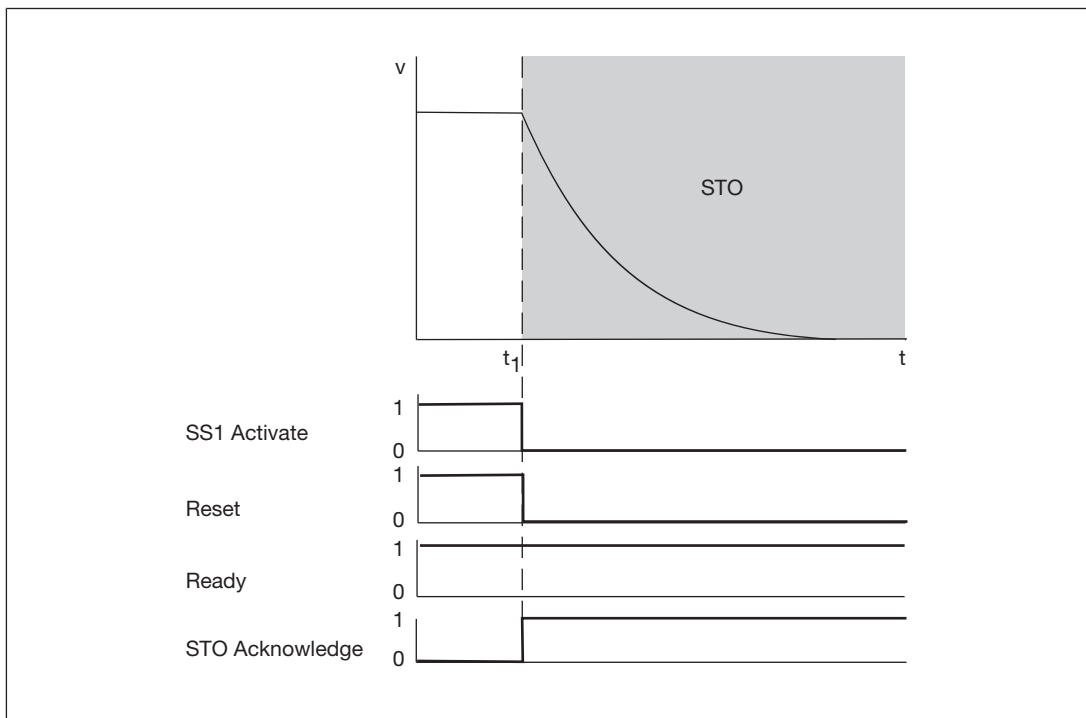

Fig.: Safety function STO

- ▶ t_1 : Safety function STO switched directly due to a "0" signal from
 - SS1 Activate: Input for safety function SS1
 - Reset: Input for reset
- ▶ Ready: Output for operating status of safety card and second output for feedback from safety function STO
- ▶ STO Acknowledge: Output for feedback from safety function STO

4.3.2 Safe stop 1 - SS1

The safety function "safe stop 1" (SS1) brakes the motor to standstill in a controlled manner and removes the power to the motor. After a defined period (STO delay time) or once the motor is at standstill, the safety function "safe torque off" (STO) removes the power to the motor.

Features of the safety function:

- ▶ The motor becomes torque-free and no longer generates any hazardous movements.
- ▶ The safety function "safe stop 1" corresponds to a category 1 stop (controlled braking) in accordance with EN 60204-1.

The safety card monitors the following functions:

- ▶ Braking ramp

In the Configurator, the braking ramp is specified and monitoring is activated. The braking period depends on the speed of the motor when braking is started.

The braking ramp can be monitored via a maximum position error specified in the Configurator.

- ▶ Braking ramp in normal operation

The drive starts with the configured braking ramp when safety function SS1 has been activated. Once the time has elapsed, STO is activated.

▶ E-STOP braking ramp:

The drive starts with the configured braking ramp when

- there is an internal error
- limit values are exceeded

▶ Safety function STO is activated when

- the actual braking period is longer than the configured STO delay time.
- the configured limit value for the position error is exceeded.
- another error occurs while SS1 is activated
- the STO delay time has elapsed

▶ Automatic STO at standstill

A standstill threshold for activating the safety function STO can be specified in the Configurator.

Safety function STO is activated when

- standstill is achieved while the STO delay time is running.
- the STO delay time has elapsed.

Input and output assignment

▶ Input

- X30/1: SS1 Activate

▶ Outputs

- X30/5: STO Acknowledge
- X30/16: Ready

Prerequisites for normal operation:

- ▶ Input "SS1 Activate" and "Reset": "1" Signal (+24 VDC)
- ▶ "Ready" output: "1" Signal (+24 VDC). The safety card is ready for operation.
- ▶ "STO Acknowledge" output: "0" Signal

Safety function is activated through

- ▶ 1/0 pulse edge at the input "SS1 Activate"
- or
- ▶ 1/0 pulse edge at the "Reset" input
- ▶ Internal error

Signal status of the inputs "SS1 Activate" and "Reset"

- ▶ The STO delay time starts when one of the two inputs "SS1 Activate" or "Reset" is set to "0". The safety function "STO" is activated once the STO delay time has elapsed.
- ▶ The safety function "STO" is activated immediately if the second input is also set to "0".
- ▶ The safety function "STO" is always activated when both the inputs "SS1 Activate" and "Reset" are set to "0".

- ▶ The method by which the servo amplifier receives the command for controlled braking of the motor is defined in the Configurator:
 - **Drive-activated:** After the safety function is triggered, the safety card issues a command to the servo amplifier for controlled braking of the motor. The braking ramp is configured in the Configurator.
 - **Controller-activated:** After the safety function is triggered, the control system issues a command to the servo amplifier for controlled braking of the motor. The braking ramp must only be configured in the Configurator if monitoring of the braking ramp is also activate there.

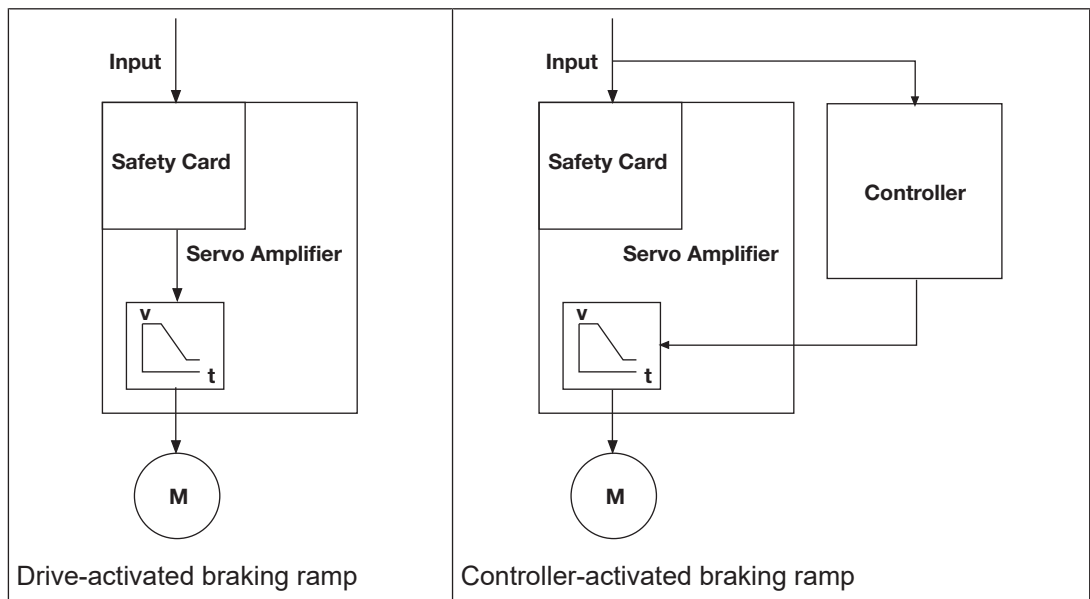

Reaction

- ▶ Controlled braking of the drive, with the configured braking ramp.
- ▶ When the STO delay time has elapsed, the safety card activates the safety function "safe torque off" (STO). The motor becomes torque-free.
- ▶ "STO Acknowledge" output: "1" Signal

If any external forces influence the motor axis (e.g. suspended loads), additional measures (e.g. a safety holding brake) are required in order to eliminate hazards.

Timing diagram: STO is started once the STO delay time has elapsed

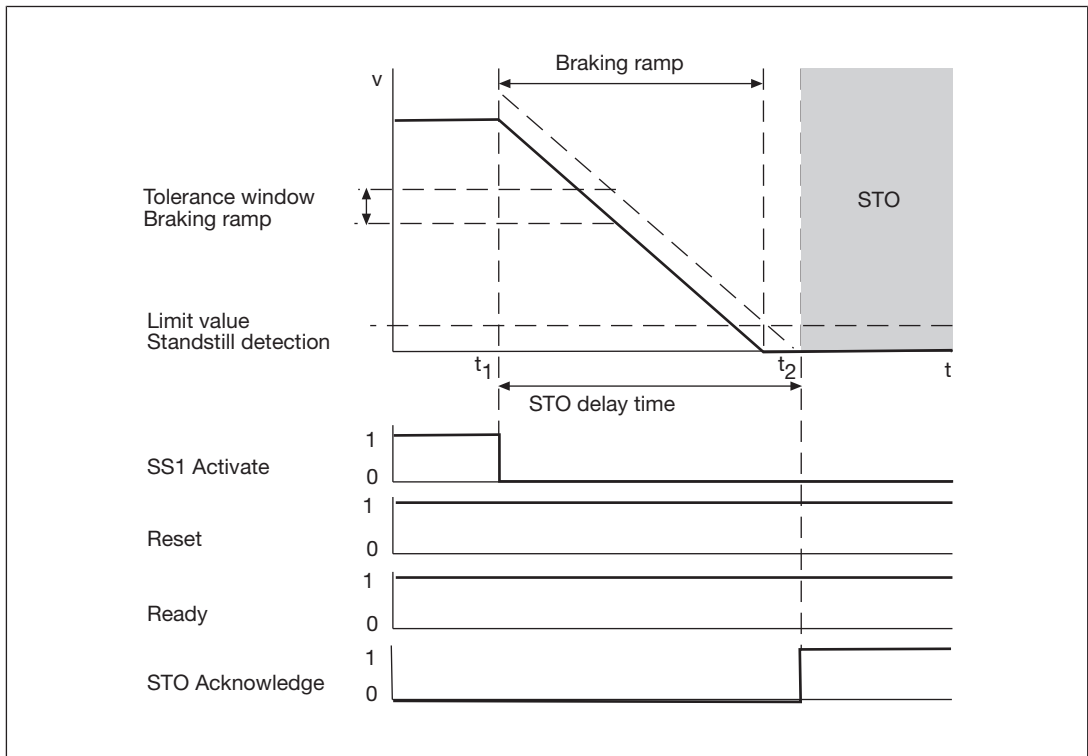

Timing diagram: STO is started during the STO delay time

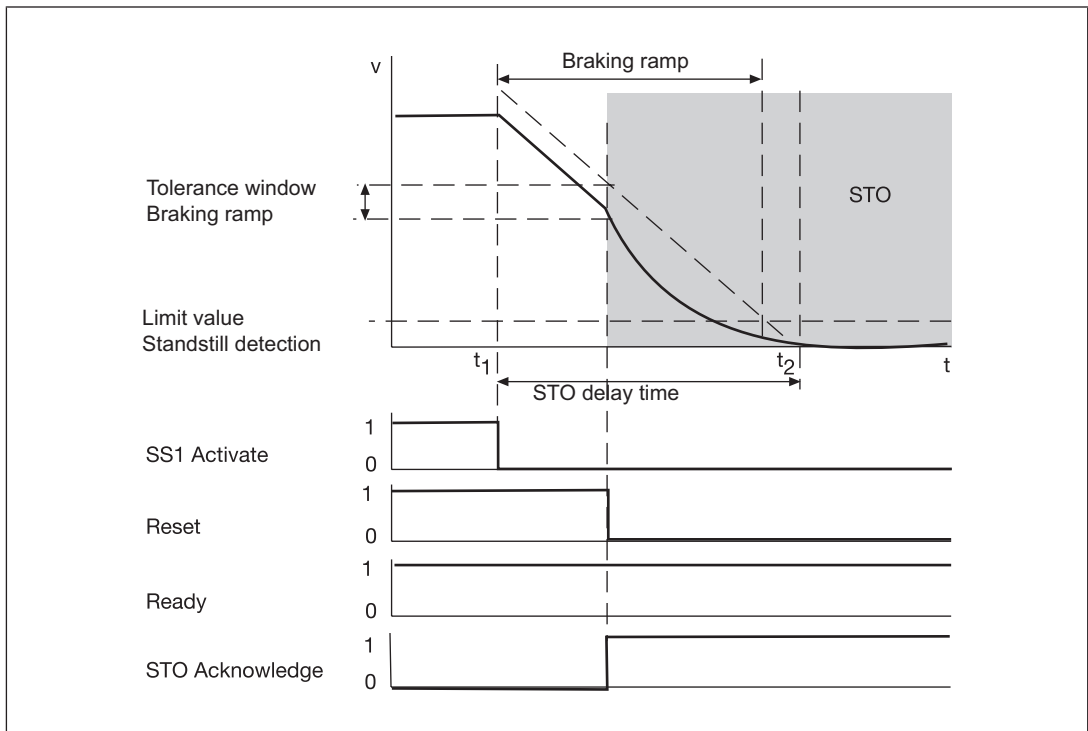

Fig.: Safety function SS1

- ▶ t_1 : Activation of safety function SS1
- ▶ t_2 : Activation of safety function STO
- ▶ SS1 Activate: Input for safety function SS1

- ▶ Reset: Input for reset
- ▶ Ready: Output for operating status of the safety card
- ▶ STO Acknowledge: Output for feedback from safety function STO

4.3.3 Safe stop 2 - SS2

The safety function "Safe Stop 2" (SS2) brakes the drive in a controlled manner and monitors it for standstill.

Features of the safety function:

- ▶ The drive's control functions are maintained. Power is applied to the motor.
- ▶ Power to the motor is not shut down.
- ▶ The safety function "Safe Stop 2" corresponds to controlled braking in accordance with IEC 60204-1, stop category 2.

The safety card monitors the following functions:

- ▶ Braking ramp

In the Configurator, the braking ramp is specified and monitoring is activated. The braking period depends on the speed of the motor when braking is started.

The braking ramp can be monitored via a maximum position error specified in the Configurator.

- ▶ Braking ramp in normal operation

The drive starts with the configured braking ramp when safety function SS2 has been activated. Once the time has elapsed, SOS is activated.

- ▶ Standstill position

- The safety function monitors whether the standstill position remains within a configured tolerance window.
- Safety function SS1 (E-STOP braking ramp) is activated if the standstill position leaves the tolerance window.

- ▶ Automatic SOS at standstill

A standstill threshold for activating the safety function SOS can be specified in the Configurator.

Safety function SOS is activated when

- standstill is achieved while the SOS delay time is running.
- the SOS delay time has elapsed.

Input and output assignment in the Configurator:

- ▶ Inputs I0 ... I6
 - SS2 Activate
- ▶ Outputs O0 ... O3
 - SSA Safe Standstill Acknowledge

Prerequisites for normal operation:

- ▶ Input "SS1 Activate" and "Reset": "1" Signal (+24 VDC)
- ▶ "Ready" output: "1" Signal (+24 VDC). The safety card is ready for operation.
- ▶ "STO Acknowledge" output: "0" Signal

Safety function is activated

- ▶ By a 1/0 pulse edge at the input "SS2 Activate".
- ▶ The method by which the servo amplifier receives the command for controlled braking of the motor is defined in the Configurator:
 - **Drive-activated:** After the safety function is triggered, the safety card issues a command to the servo amplifier for controlled braking of the motor. The braking ramp is configured in the Configurator.
 - **Controller-activated:** After the safety function is triggered, the control system issues a command to the servo amplifier for controlled braking of the motor. The braking ramp must only be configured in the Configurator if monitoring of the braking ramp is also activate there.

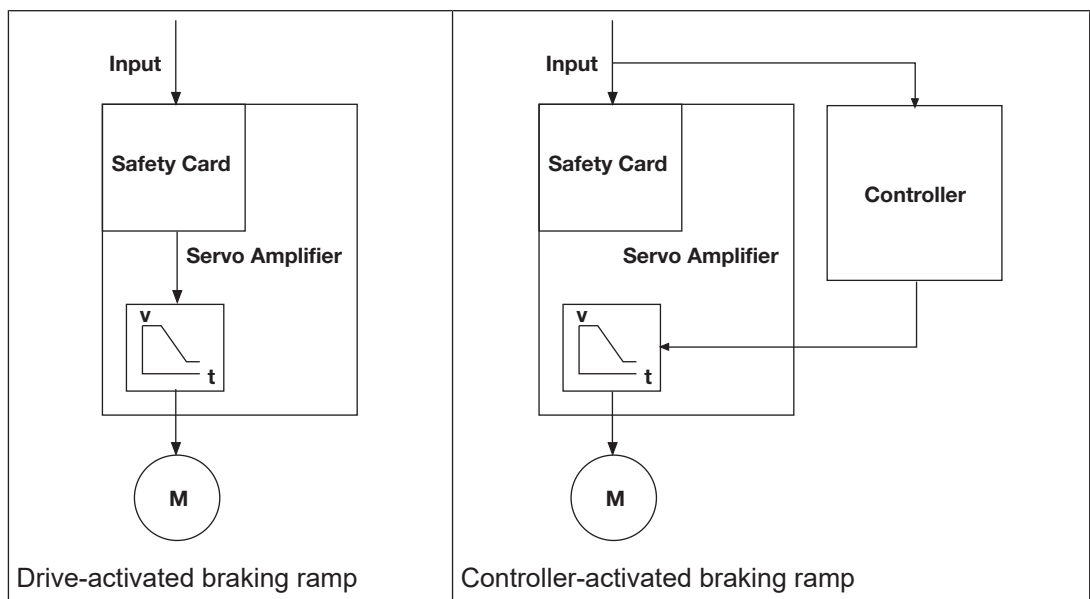

Reaction:

- ▶ Controlled braking of the drive, with the configured braking ramp.
- ▶ The drive remains in a controlled standstill and is monitored for "safe standstill".
- ▶ Output "SSA Safe Standstill Acknowledge": "1" signal

Timing diagram:

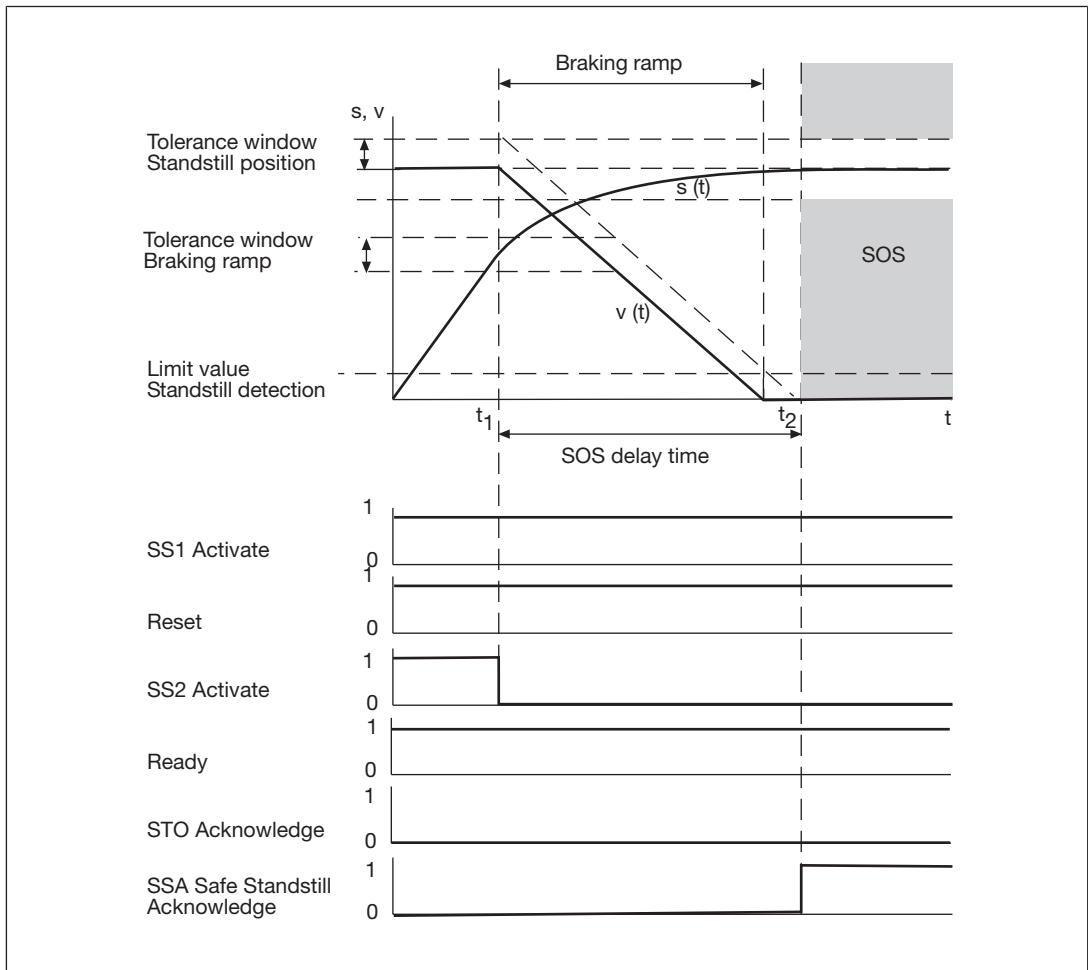

Fig.: Safety function SS2

- ▶ t_1 : Activation of safety function SS2
- ▶ t_2 : Activation of safety function SOS
- ▶ SS1 Activate: Input for safety function SS1
- ▶ Reset: Input for reset
- ▶ SS2 Activate: Input for safety function SS2
- ▶ Ready: Output for operating status of safety card and second output for feedback from safety function STO
- ▶ STO Acknowledge: Output for feedback from safety function STO
- ▶ SSA Safe Standstill Acknowledge: Output for feedback from limit value monitoring

4.3.4 Safe operating stop - SOS

The safety function "safe operating stop" (SOS) monitors the standstill position that has been reached. An error will activate safety function SS1 (E-STOP braking ramp).

Features of the safety function:

- ▶ The drive's control functions are maintained in the standstill position.
- ▶ Power to the motor is not shut down.

The safety card monitors the following functions:

▶ Standstill position

- The safety function monitors whether the standstill position remains within a configured tolerance window.
- Safety function SS1 (E-STOP braking ramp) is activated if the standstill position leaves the tolerance window.

▶ Automatic SOS at standstill

A standstill threshold for activating the safety function SOS can be specified in the Configurator.

Safety function SOS is activated when

- standstill is achieved while the SOS delay time is running.
- the SOS delay time has elapsed.

Input and output assignment in the Configurator:

▶ Inputs I0 ... I6

- SOS Activate

▶ Outputs O0 ... O3

- SSA Safe Standstill Acknowledge

Prerequisites for normal operation:

- ▶ Input "SS1 Activate" and "Reset": "1" Signal (+24 VDC)
- ▶ "Ready" output: "1" Signal (+24 VDC). The safety card is ready for operation.
- ▶ "STO Acknowledge" output: "0" Signal
- ▶ Input "SOS Activate": "1" Signal (+24 VDC)

Safety function is activated

- ▶ By a 1/0 pulse edge at the input "SOS Activate".

Reaction:

- ▶ SOS delay time starts
- ▶ Once the SOS delay time has elapsed, safe standstill is monitored. The drive remains in a controlled standstill.
- ▶ Output "SSA Safe Standstill Acknowledge": "1" signal
- ▶ Safety function SS1 (E-STOP braking ramp) shuts the drive down safely if the limit value for the standstill position is exceeded. An error is registered.

Timing diagram

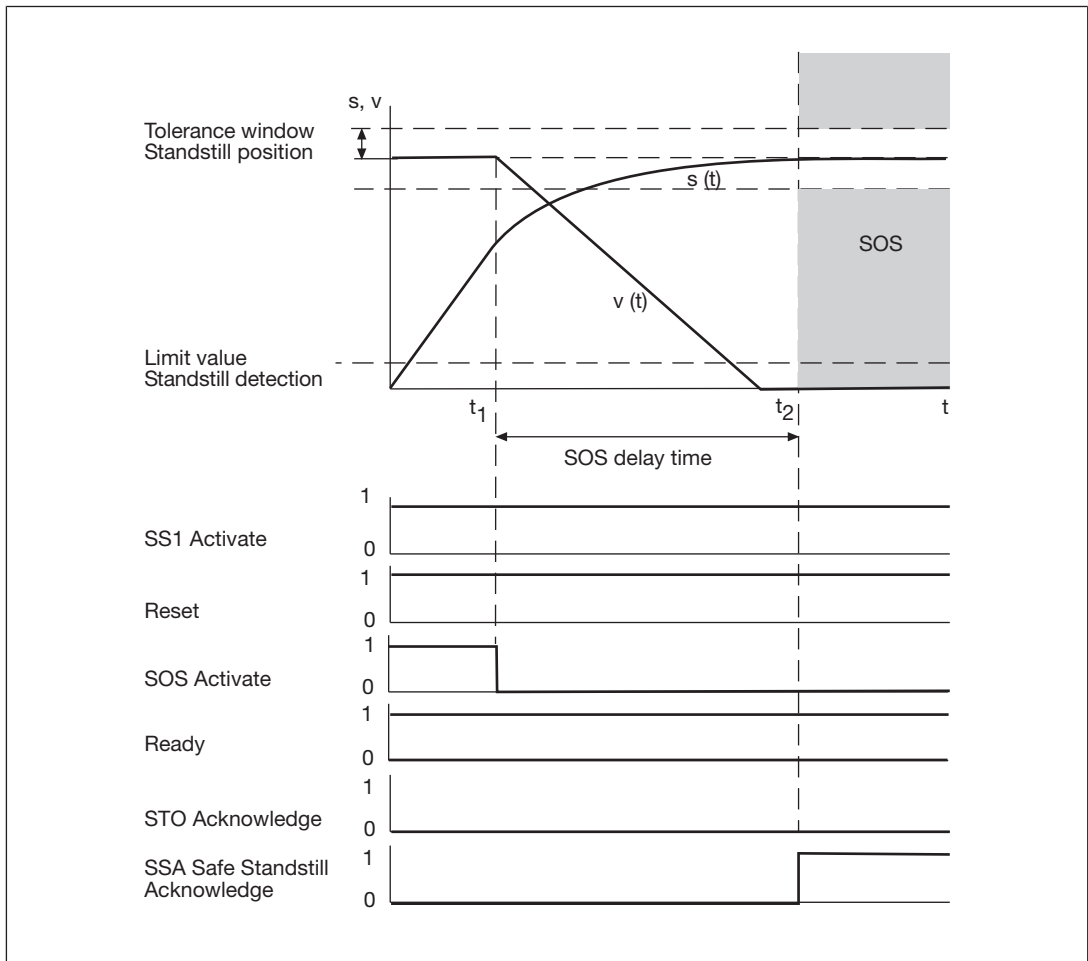

Fig.: Safety function SOS

- ▶ t_1 : Activation of safety function SOS
- ▶ t_2 : Once the SOS delay time has elapsed, standstill position is monitored
- ▶ SS1 Activate: Input for safety function SS1
- ▶ Reset: Input for reset
- ▶ SOS-Activate: Input for safety function SOS
- ▶ Ready: Output for operating status of safety card and second output for feedback from safety function STO
- ▶ STO Acknowledge: Output for feedback from safety function STO
- ▶ SSA Safe Standstill Acknowledge: Output for feedback from limit value monitoring

4.3.5 Safely limited speed - SLS

The safety function "safely limited speed" (SLS) monitors the drive to check that it stays within a defined speed limit.

Input and output assignment in the Configurator:

- ▶ Inputs I0 ... I6
 - SLS Activate
- ▶ Outputs O0 ... O3
 - SRA Safe Range Acknowledge

Prerequisites for normal operation:

- ▶ Input "SS1 Activate" and "Reset": "1" Signal (+24 VDC)
- ▶ "Ready" output: "1" Signal (+24 VDC). The safety card is ready for operation.
- ▶ "STO Acknowledge" output: "0" Signal
- ▶ Input "SLS Activate": "1" Signal (+24 VDC)

Safety function is activated

- ▶ By a 1/0 pulse edge at the input "SLS Activate".

Reaction:

- ▶ SLS delay time starts
- ▶ Once the SLS delay time has elapsed, the speed is monitored.
- ▶ Output "SRA Safe Range Acknowledge": "1" signal
- ▶ If the limit value is exceeded, safety function SS1 (E-STOP braking ramp) is activated.

A tolerance range may also be set for the limit values used to monitor the speed. This tolerance range modifies the set limit values. As a result, one-off or periodic overshoots that exceed the limit values can be tolerated.

The following values can be set for the tolerance range:

- ▶ Tolerance amount, which takes into account the size of the overshoots.
- ▶ Tolerance time, which takes into account the length of the overshoots
- ▶ Tolerance period that takes into account the variation period



INFORMATION

See the Configurator's online help for details of how to set the parameters for the tolerance range.

Activate the tolerance range:

- ▶ The tolerance range becomes active the first time the speed limit value is exceeded (see flowchart).

Reaction:

- ▶ If the tolerance range is exceeded, the safety function SS1 (E-STOP braking ramp) is activated.

The following diagrams illustrate the sequences, with and without the tolerance range activated.

Timing diagram without tolerance range activated

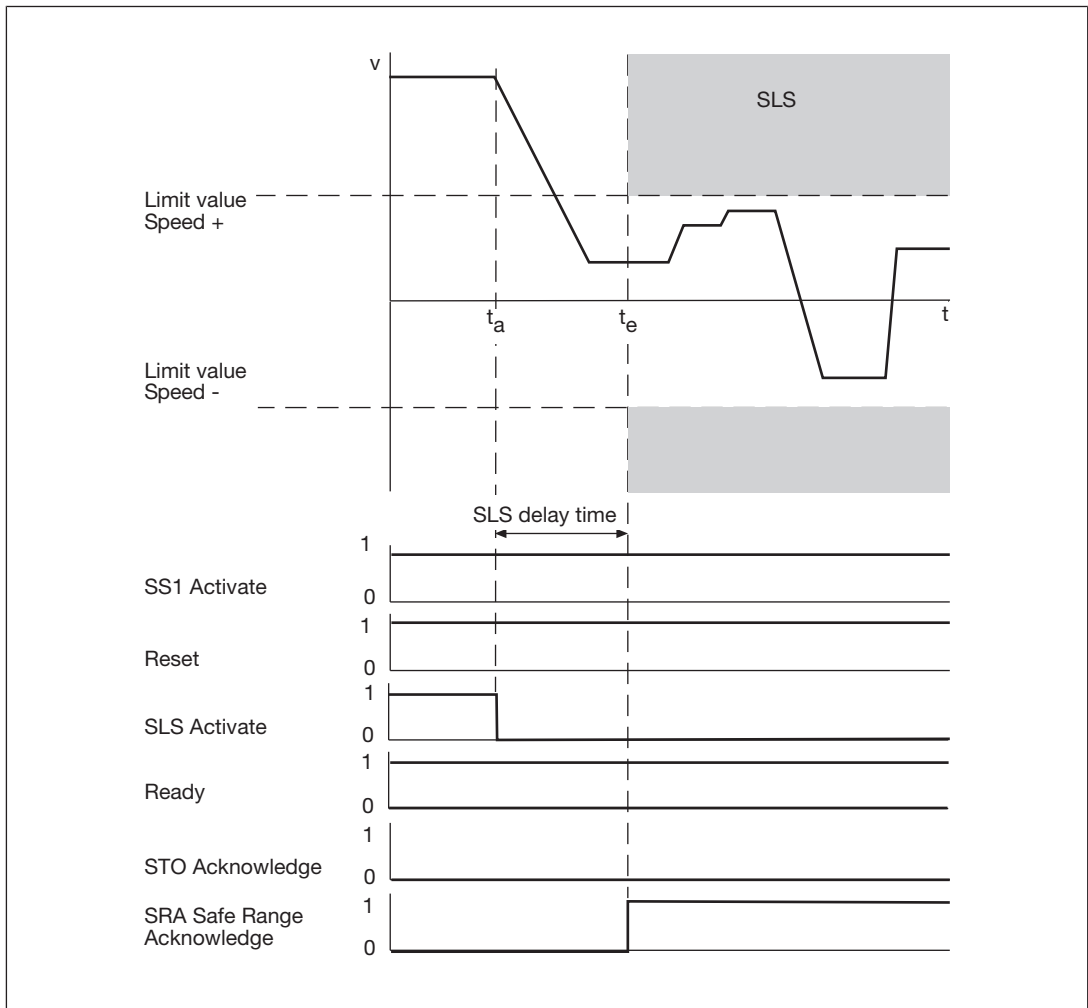

Fig.: Safety function SLS without tolerance range activated

- ▶ t_a : Activation of safety function SLS
- ▶ t_e : Once the SLS delay time has elapsed, the speed is monitored
- ▶ SS1 Activate: Input for safety function SS1
- ▶ Reset: Input for reset
- ▶ SLS Activate: Input for safety function SLS
- ▶ Ready: Output for operating status of safety card and second output for feedback from safety function STO
- ▶ STO Acknowledge: Output for feedback from safety function STO
- ▶ SRA Safe Range Acknowledge: Output for monitoring the limit value on the motor

Timing diagram with tolerance range activated

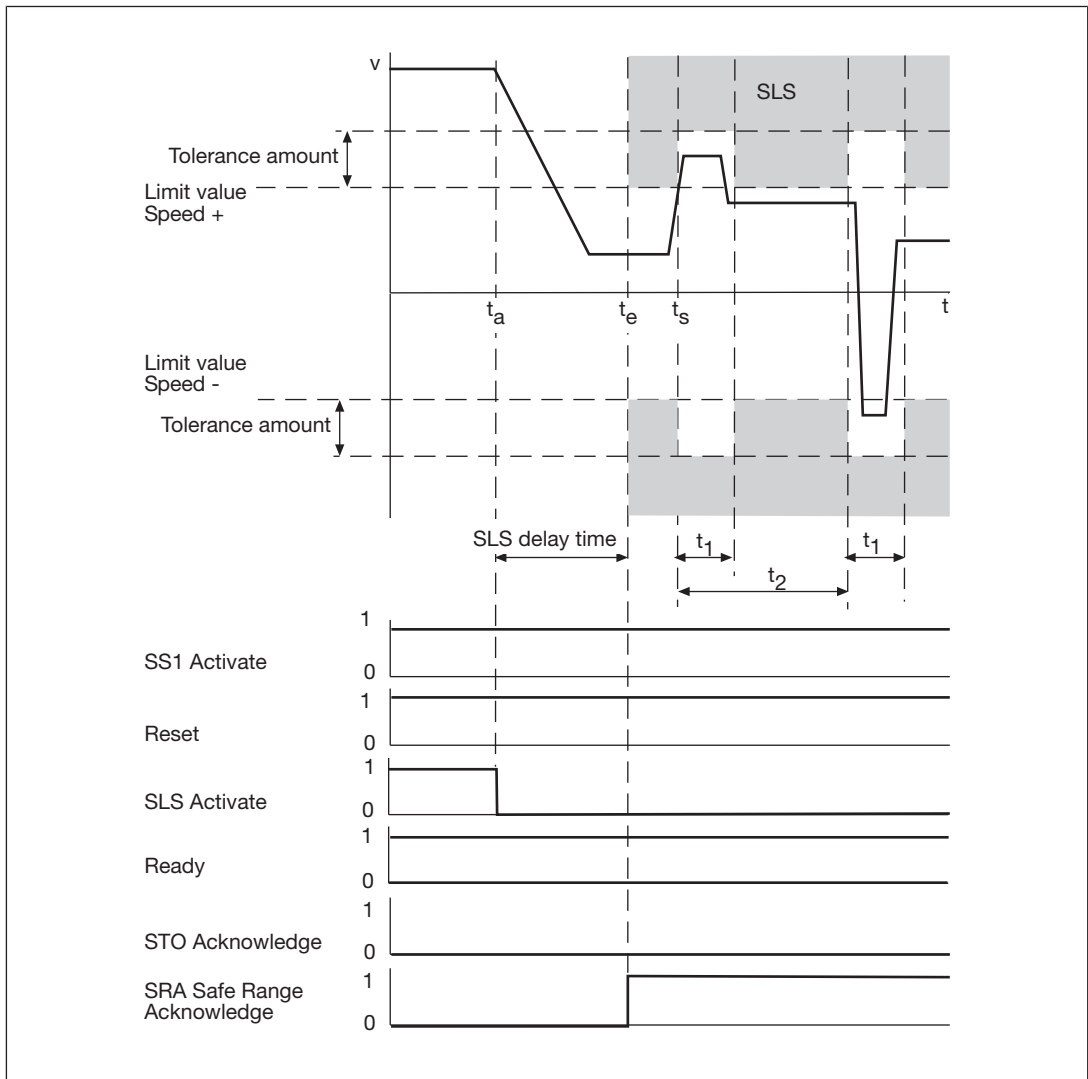

Fig.: Safety function SLS with tolerance range activated

- ▶ Tolerance amount as % of the speed limit value
- ▶ t_a : Activation of safety function SLS
- ▶ t_e : Once the SLS delay time has elapsed, the speed is monitored
- ▶ t_s : Speed v exceeds the limit value and activates the tolerance range (tolerance amount, tolerance time, tolerance period)
- ▶ t_1 : Tolerance time
- ▶ t_2 : Tolerance period
- ▶ SS1 Activate: Input for safety function SS1
- ▶ Reset: Input for reset
- ▶ SLS Activate: Input for safety function SLS
- ▶ Ready: Output for operating status of safety card and second output for feedback from safety function STO
- ▶ STO Acknowledge: Output for feedback from safety function STO
- ▶ SRA Safe Range Acknowledge: Output for monitoring the limit value on the motor

4.3.6 Safe speed range - SSR

The safety function "safe speed range" (SSR) monitors the drive's current speed to ensure it stays within a maximum and minimum permitted limit value.

Input and output assignment in the Configurator:

- ▶ Inputs I0 ... I6
 - SSR Activate
- ▶ Outputs O0 ... O3
 - SRA Safe Range Acknowledge

Prerequisites for normal operation:

- ▶ Input "SS1 Activate" and "Reset": "1" Signal (+24 VDC)
- ▶ "Ready" output: "1" Signal (+24 VDC). The safety card is ready for operation.
- ▶ "STO Acknowledge" output: "0" Signal
- ▶ Input "SSR Activate": "1" Signal (+24 VDC)

Safety function is activated

- ▶ By a 1/0 pulse edge at the input "SSR Activate".

Reaction:

- ▶ SSR delay time starts
- ▶ Once the SSR delay time has elapsed, the speed is monitored.
- ▶ Output "SRA Safe Range Acknowledge": "1" signal
- ▶ If the limit value is exceeded, safety function SS1 is activated.

A tolerance range may also be set for the limit values used to monitor the speed. This tolerance range modifies the set limit values. As a result, one-off or periodic overshoots that exceed the limit values can be tolerated.

The following values can be set for the tolerance range:

- ▶ Tolerance amount, which takes into account the size of the overshoots.
- ▶ Tolerance time, which takes into account the length of the overshoots
- ▶ Tolerance period that takes into account the variation period



INFORMATION

See the Configurator's online help for details of how to set the parameters for the tolerance range.

Activate the tolerance range:

- ▶ The tolerance range becomes active the first time the speed limit value is exceeded (see flowchart).

Reaction:

- ▶ If the tolerance range is exceeded, the safety function SS1 (E-STOP braking ramp) is activated.

The following diagrams illustrate the sequences, with and without the tolerance range activated.

Timing diagram without tolerance range activated

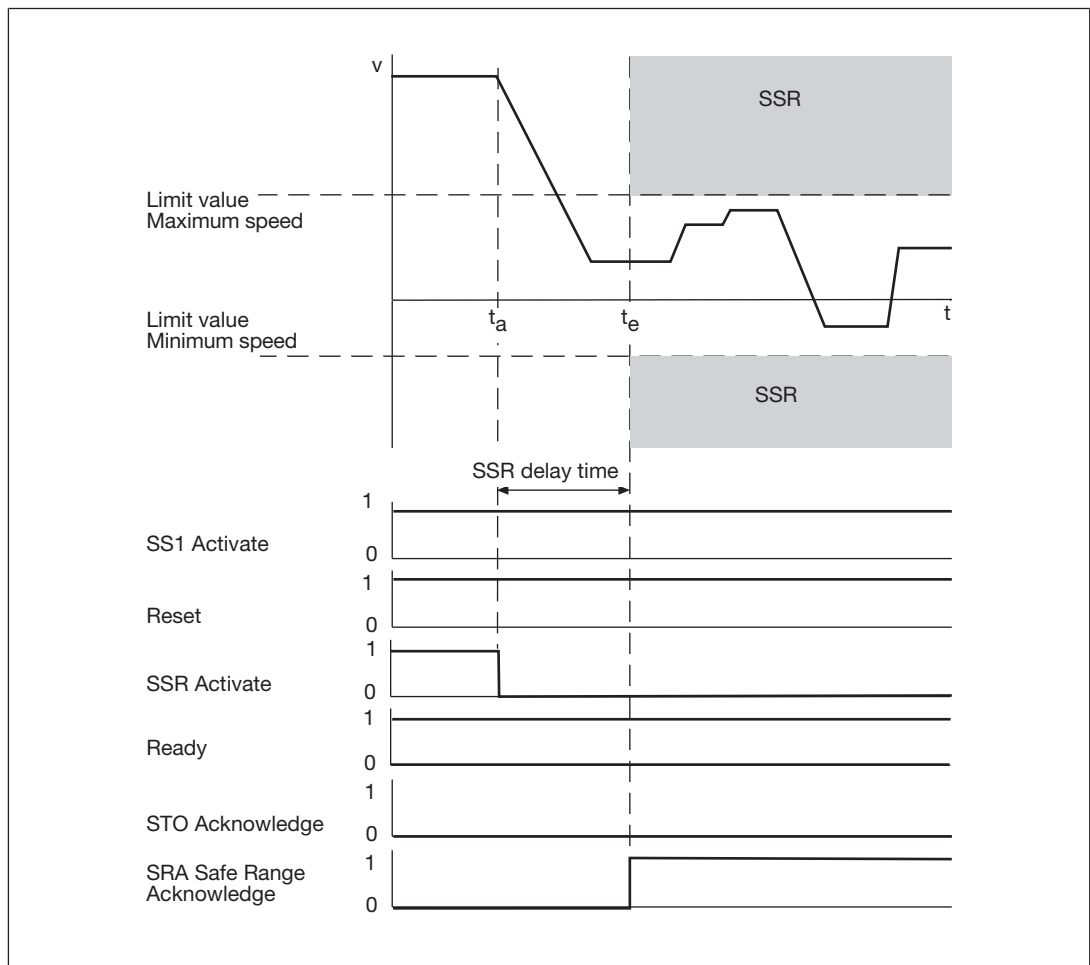

Fig.: Safety function SSR without tolerance range activated

- ▶ t_a : Activation of safety function SSR
- ▶ t_e : Once the SSR delay time has elapsed, the speed is monitored
- ▶ SS1 Activate: Input for safety function SS1
- ▶ Reset: Input for reset
- ▶ SSR Activate: Input for safety function SSR
- ▶ Ready: Output for operating status of safety card and second output for feedback from safety function STO
- ▶ STO Acknowledge: Output for feedback from safety function STO
- ▶ SRA Safe Range Acknowledge: Output for monitoring the limit value on the motor

Timing diagram with tolerance range activated

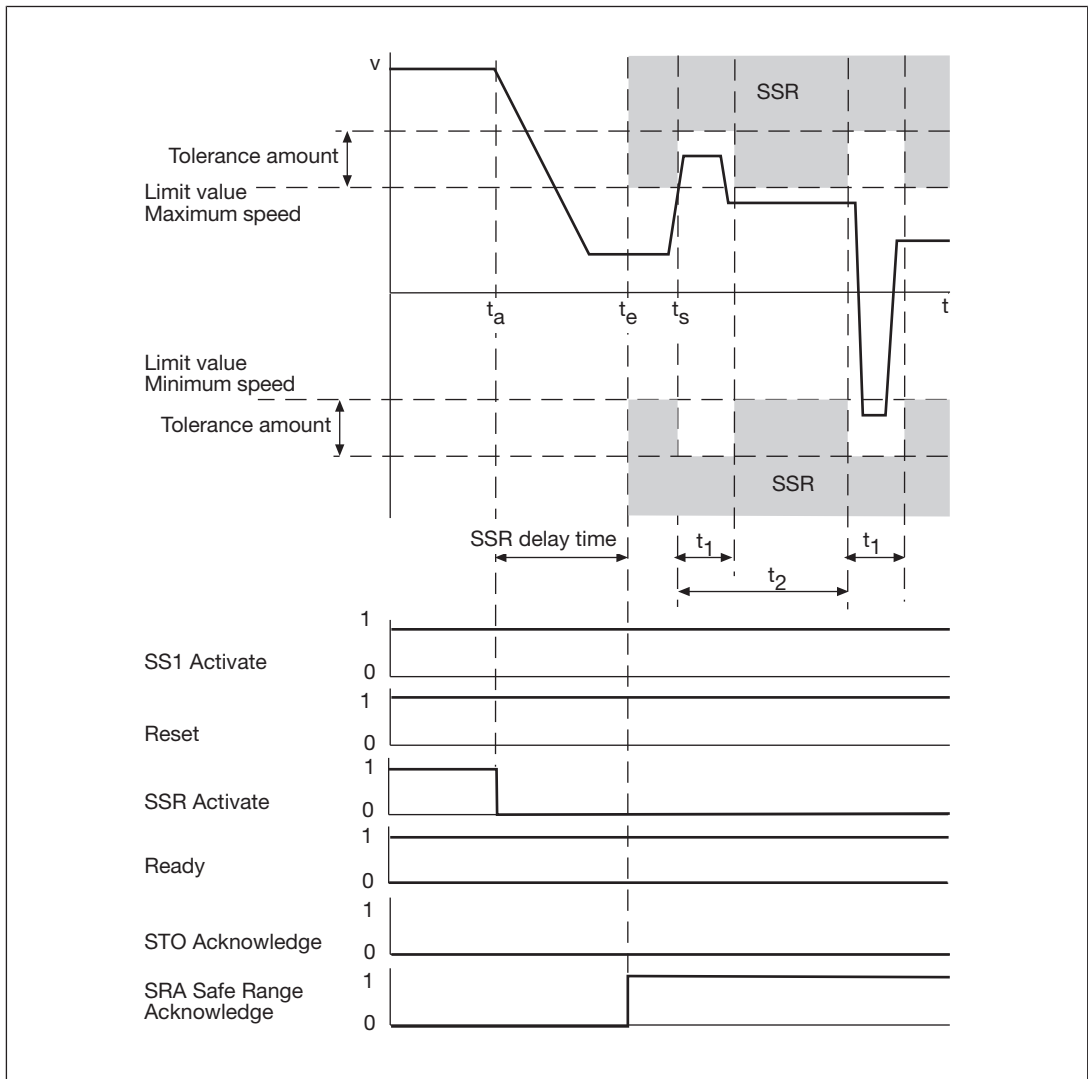

Fig.: Safety function SSR with tolerance range activated

- ▶ Tolerance amount as % of the two limit values, maximum and minimum speed
- ▶ t_a : Activation of safety function SSR
- ▶ t_e : Once the SSR delay time has elapsed, the speed is monitored
- ▶ t_s : Speed v exceeds the limit value and activates the tolerance range (tolerance amount, tolerance time, tolerance period)
- ▶ t_1 : Tolerance time
- ▶ t_2 : Tolerance period
- ▶ SS1 Activate: Input for safety function SS1
- ▶ Reset: Input for reset
- ▶ SSR Activate: Input for safety function SSR
- ▶ Ready: Output for operating status of safety card and second output for feedback from safety function STO
- ▶ STO Acknowledge: Output for feedback from safety function STO
- ▶ SRA Safe Range Acknowledge: Output for monitoring the limit value on the motor

4.3.7 Safe direction - SDI

The safety function "safe direction" (SDI) monitors the defined direction of rotation of the drive axis (clockwise or anti-clockwise).

Input and output assignment in the Configurator:

- ▶ Inputs I0 ... I6
 - SDI Neg. Activate
 - SDI Pos. Activate
- ▶ Outputs O0 ... O3
 - SDA Safe Direction Acknowledge

Prerequisites for normal operation:

- ▶ Input "SS1 Activate" and "Reset": "1" Signal (+24 VDC)
- ▶ "Ready" output: "1" Signal (+24 VDC). The safety card is ready for operation.
- ▶ "STO Acknowledge" output: "0" Signal
- ▶ Input "SDI Pos Activate": "1" Signal (+24 VDC)
- ▶ Input "SDI Neg Activate": "1" Signal (+24 VDC)

The safety function is activated via

- ▶ 1/0 pulse edge at the input "SDI Pos Activate"
- or
- ▶ 1/0 pulse edge at the input "SDI Neg Activate"

Reaction:

- ▶ SDI delay time starts
- ▶ Once the SDI delay time has elapsed, the direction of rotation is monitored
- ▶ Output "SDA Safe Direction Acknowledge": "1" signal
- ▶ If the direction of rotation is violated, safety function SS1 (E-STOP braking ramp) is activated.

Timing diagram:

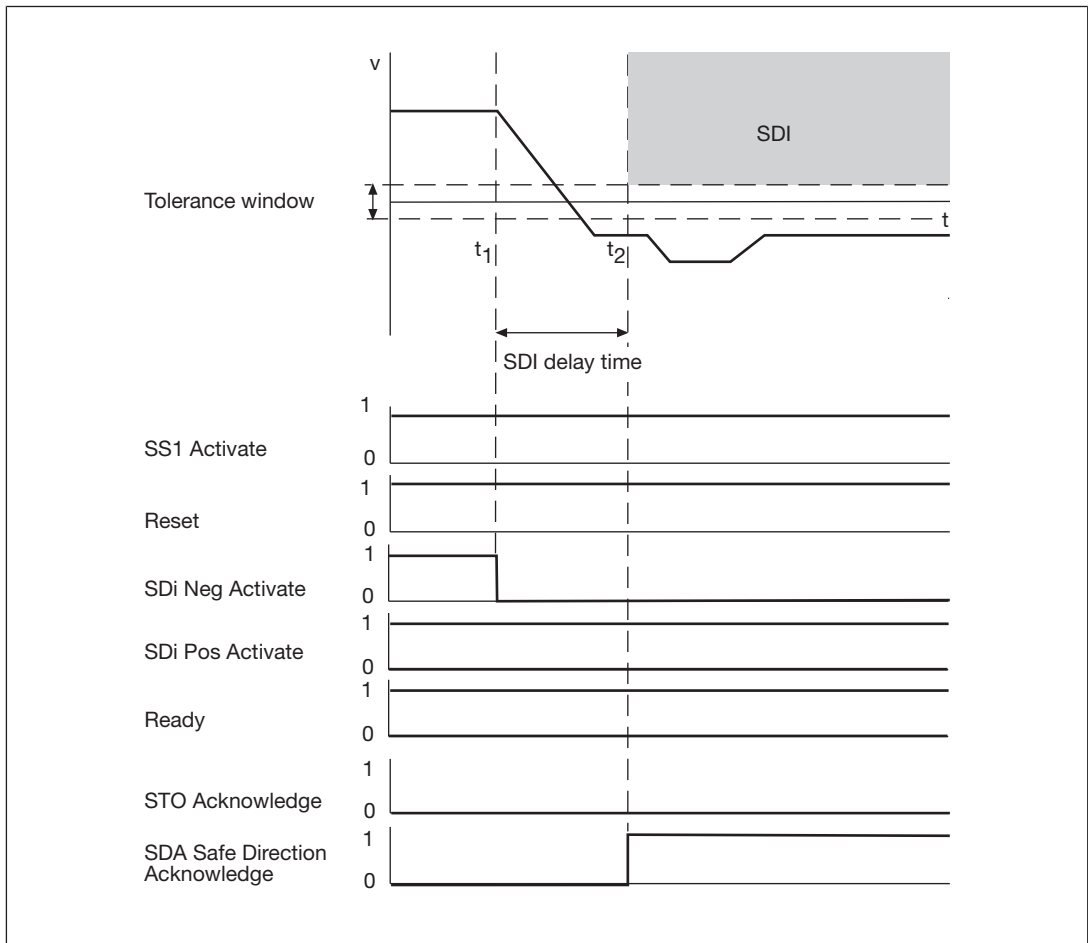

Fig.: Safety function SDI

- ▶ t_1 : Activation of safety function SDI
- ▶ t_2 : Once the SDI delay time has elapsed, the direction of rotation is monitored
- ▶ SS1 Activate: Input for safety function SS1
- ▶ Reset: Input for reset
- ▶ SDI Pos Activate: Input for safety function SDI, clockwise rotation is monitored
- ▶ SDI Neg Activate: Input for safety function SDI, anti-clockwise rotation is monitored
- ▶ Ready: Output for operating status of safety card and second output for feedback from safety function STO
- ▶ STO Acknowledge: Output for feedback from safety function STO
- ▶ SDA Safe Direction Acknowledge: Output for feedback from safety function SDI

Switching the direction of rotation while safety function SDI is active

- ▶ When changing the direction of the motor, please note: Monitoring of the old direction must be deactivated first, before monitoring of the new direction of rotation is activated! (See Case A in the illustration). If an SDI delay time t_m has been configured, it will start when the new direction of rotation monitoring is activated. In A, the SDI delay time t_m is shown = 0.

- ▶ The SDI delay time can be used to optimise the time taken to switch the direction of rotation. The new direction can be activated while the SDI delay time t_m is running. Only then is monitoring of the old direction of rotation deactivated (see Case B in the illustration and timing diagram).



NOTICE

Please note that the direction of rotation may only ever be monitored in one direction. The safety function SS1 will trigger if monitoring in both directions is activated simultaneously.

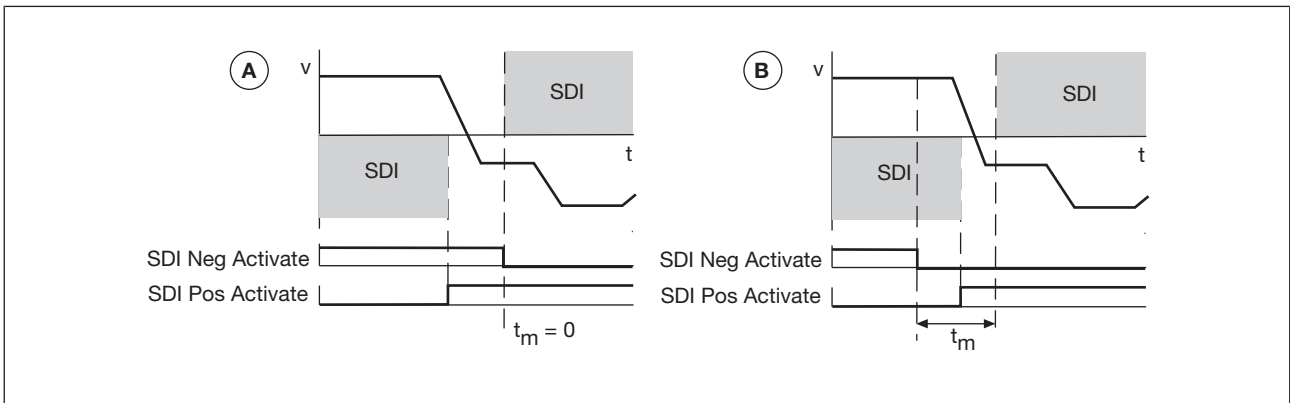

Fig.: Changing the direction of rotation

Timing diagram:

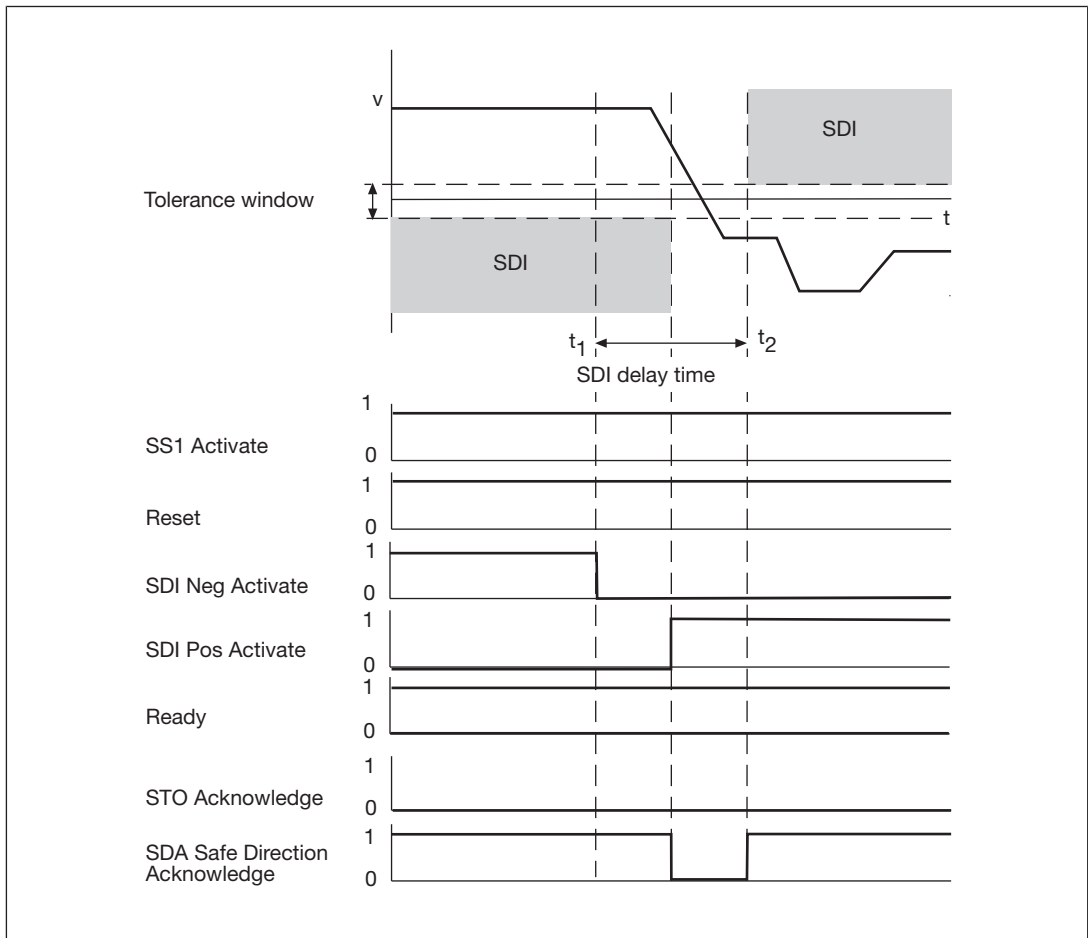

Fig.: Changing the direction of rotation with SDI delay time

- ▶ t_1 : Activation of safety function SDI in negative direction of rotation
- ▶ t_2 : Once the SDI delay time has elapsed, the negative direction of rotation is monitored
- ▶ SS1 Activate: Input for safety function SS1
- ▶ Reset: Input for reset
- ▶ SDI Neg Activate: Input for safety function SDI, anti-clockwise rotation is monitored (new direction of rotation)
- ▶ SDI Pos Activate: Input for safety function SDI, clockwise rotation is monitored (old direction of rotation)
- ▶ Ready: Output for operating status of safety card and second output for feedback from safety function STO
- ▶ STO Acknowledge: Output for feedback from safety function STO
- ▶ SDA Safe Direction Acknowledge: Output for feedback from safety function SDI

4.3.8 Safely Limited Increment - SLI

The safety function "Safely Limited Increment" (SLI) monitors the movement of the drive for compliance with a defined increment.

Input and output assignment in the Configurator:

- ▶ Inputs I0 ... I6
 - SLI Activate
- ▶ Outputs O0 ... O3
 - SRA Safe Range Acknowledge
 - SSA Safe Standstill Acknowledge

Prerequisites for normal operation:

- ▶ Input "SS1 Activate" and "Reset": "1" Signal (+24 VDC)
- ▶ "Ready" output: "1" Signal (+24 VDC). The safety card is ready for operation.
- ▶ "STO Acknowledge" output: "0" Signal
- ▶ Input "SLI Activate": "1" signal (+24 VDC)

The safety function is activated via

- ▶ 1/0 pulse edge at the input "SLI Activate".

Reaction:

- ▶ SLI delay time starts
- ▶ Once the SLI delay time has elapsed, the safe increment and the safely limited speed are monitored. The current position of the motor is recorded and the motor is monitored for compliance with the maximum increment.
- ▶ Increment and speed within permitted limits:
 - Output "SRA Safe Range Acknowledge": "1" signal
- ▶ If an increment or the speed is exceeded, the safety function SS1 (E-STOP braking ramp) is activated.

Options

- ▶ Check standstill
 - In the Configurator you can define whether the motor must be at standstill at the time that SLI is activated or whether it may be in motion. A limit value may be specified for detecting standstill.
 - Safety function SS1 (E-STOP braking ramp) is activated if the limit value is exceeded.
- ▶ Automatic activation after standstill
 - Monitoring of the next increment starts automatically if the drive is below the limit value for standstill.
 - Between two monitored increments, standstill can be monitored for a specified standstill time. While this monitoring function is carried out, the output "SSA Safe Standstill Acknowledge" = "1".
 - A tolerance window may be specified for standstill monitoring. If the value is exceeded, safety function SS1 (E-STOP braking ramp) is activated.

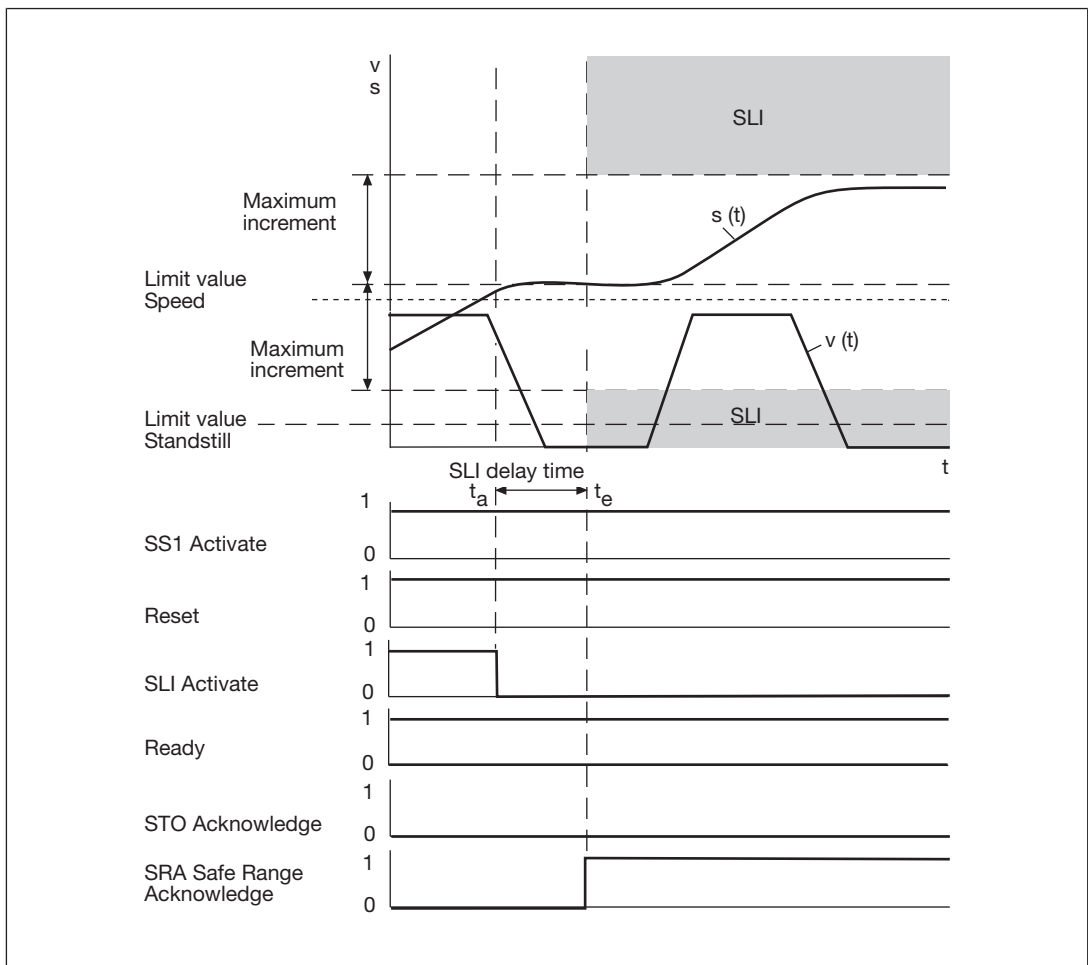

Fig.: Safety function SLI without automatic activation

- ▶ t_a : Activation of safety function SLI
- ▶ t_e : Once the SLI delay time has elapsed, the increment is monitored.
- ▶ SS1 Activate: Input for safety function SS1
- ▶ Reset: Input for reset
- ▶ SLI Activate: Input for safety function SLI
- ▶ Ready: Output for operating status of safety card and second output for feedback from safety function STO
- ▶ STO Acknowledge: Output for feedback from safety function STO
- ▶ SRA Safe Range Acknowledge: Output for monitoring the limit value on the motor

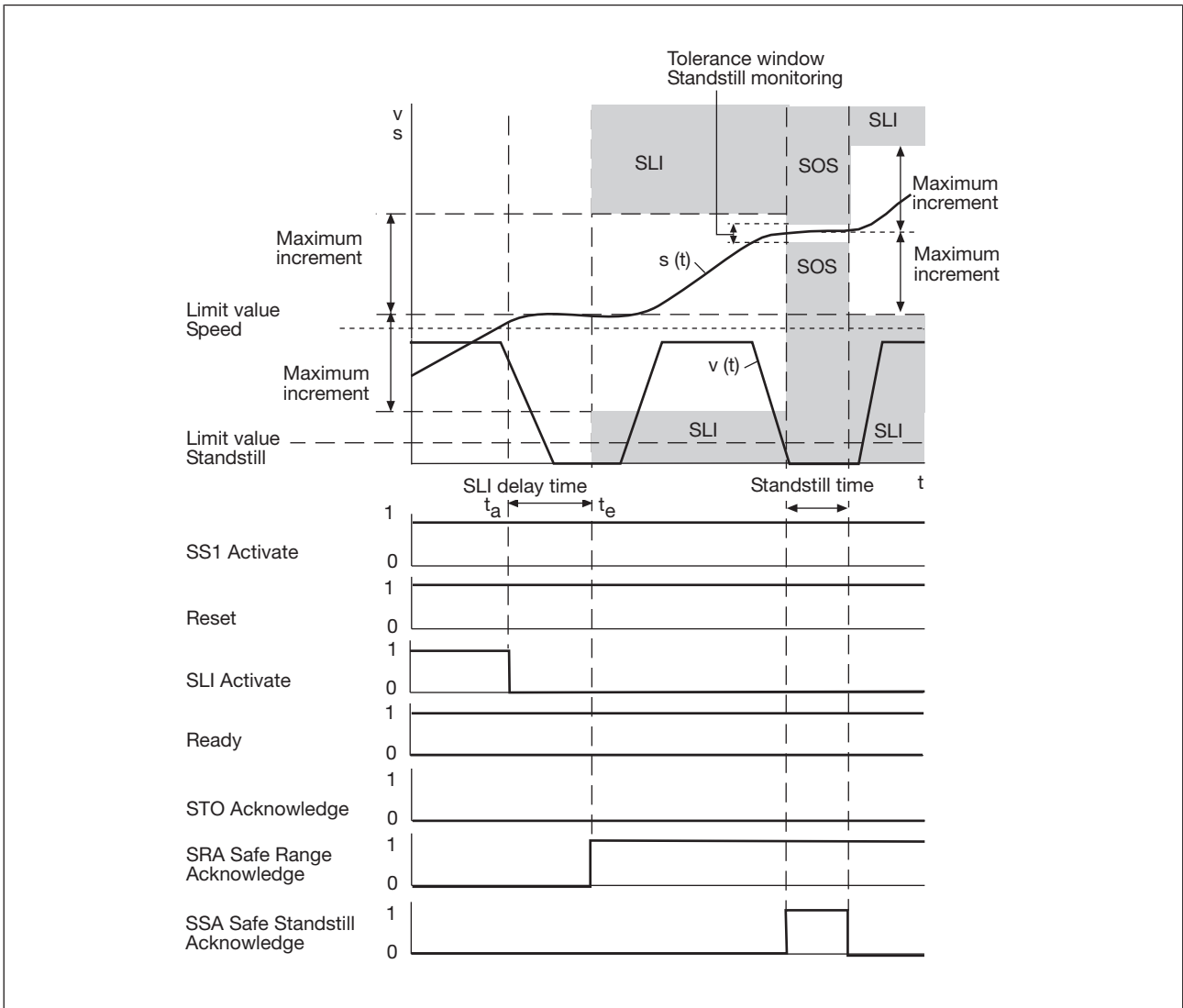

Fig.: Safety function SLI with automatic activation

- ▶ t_a : Activation of safety function SLI
- ▶ t_e : Once the SLI delay time has elapsed, the increment is monitored.
- ▶ SS1 Activate: Input for safety function SS1
- ▶ Reset: Input for reset
- ▶ SLI Activate: Input for safety function SLI
- ▶ Ready: Output for operating status of safety card and second output for feedback from safety function STO
- ▶ STO Acknowledge: Output for feedback from safety function STO
- ▶ SRA Safe Range Acknowledge: Output for monitoring the limit value on the motor
- ▶ SSA Safe Standstill Acknowledge: Output for feedback from monitoring the standstill limit value

4.4 Operating mode of the servo amplifier

Activation of safety functions SS1 and SS2 has repercussions on the servo amplifier's operating mode:

SS1 when OPMODE = 0 ... 8

- ▶ The drive-activated safety function "safe stop 1" (SS1) behaves the same in all of the servo amplifier's operating modes, as ultimately the movement is not continued. The safety card must be reset to resume operation.
- ▶ The status of the safety card (SS1 activated) is transmitted to the servo amplifier. As a result, the information is available to a higher level control system (status word).
- ▶ The transfer of setpoint values from external servo amplifier interfaces (bus system or analogue input) is disabled.
- ▶ The servo amplifier applies speed-controlled braking with the preset braking ramp until standstill is achieved, and disables the servo amplifier's power element.
- ▶ When the set delay time has elapsed, the safety card activates the safety function STO. The servo amplifier cannot be restarted.

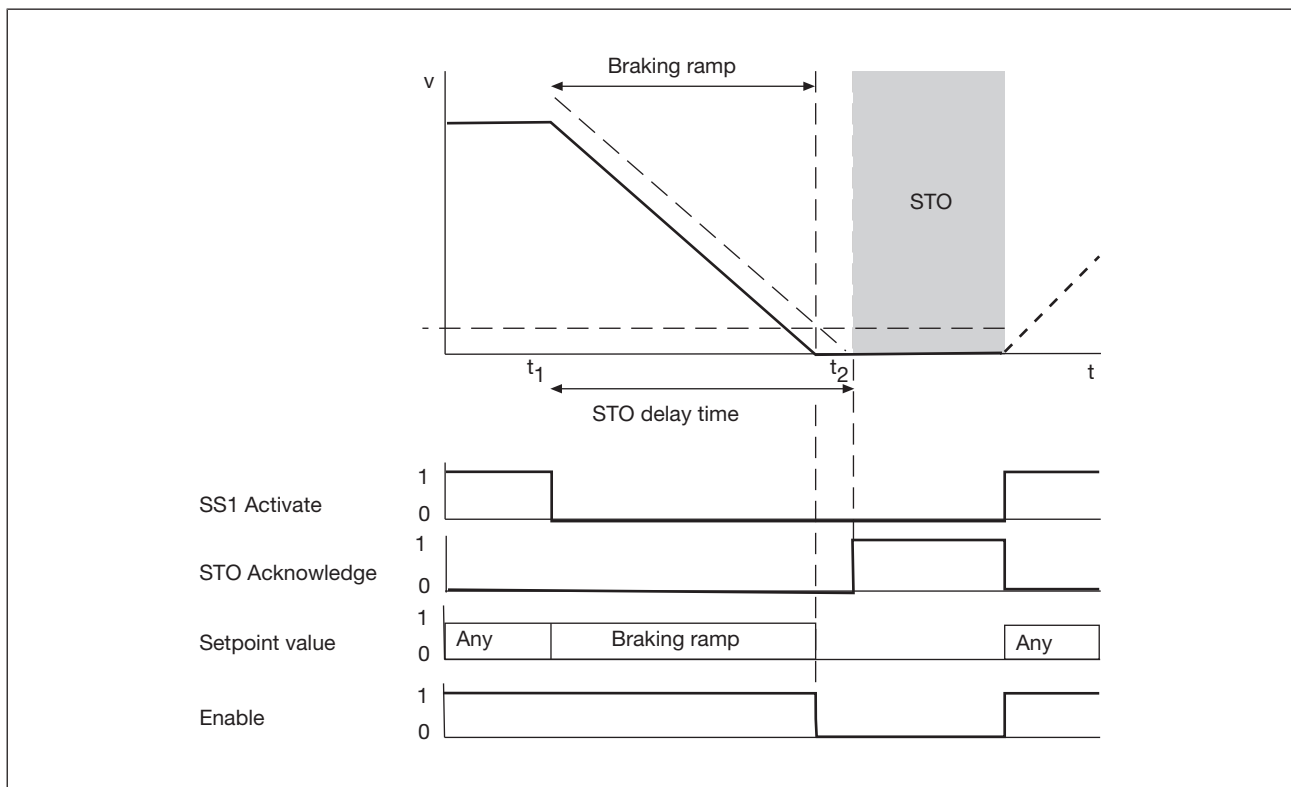

- ▶ **SS1 Activate:** Input for safety function SS1
- ▶ **STO Acknowledge:** Output for feedback from safety function STO
- ▶ **Setpoint value:** Specification of setpoint values
- ▶ **Enable:** Servo amplifier's readiness for operation

SS2 when OPMODE = 0 ... 8

- ▶ With the drive-activated safety function "safe stop 2" (SS2), the movement is ultimately continued.
- ▶ The status of the safety card (SS2 activated) is transmitted to the servo amplifier. As a result, the information is available to a higher level control system (status word).

- ▶ The transfer of setpoint values from external servo amplifier interfaces (bus system or analogue input) is disabled.
- ▶ The servo amplifier applies speed-controlled braking with the preset braking ramp until standstill is achieved.
This status is maintained for as long as safety function SS2 is active.
- ▶ If safety function SS2 is deactivated, the status word is updated.
- ▶ The servo amplifier automatically switches to the OPMODE that was originally set.
- ▶ The transfer of setpoint values from external servo amplifier interfaces (bus system or analogue input) is once again permitted.
- ▶ When OPMODE = 8, the existing motion block can be continued via the "CONTINUE" command.

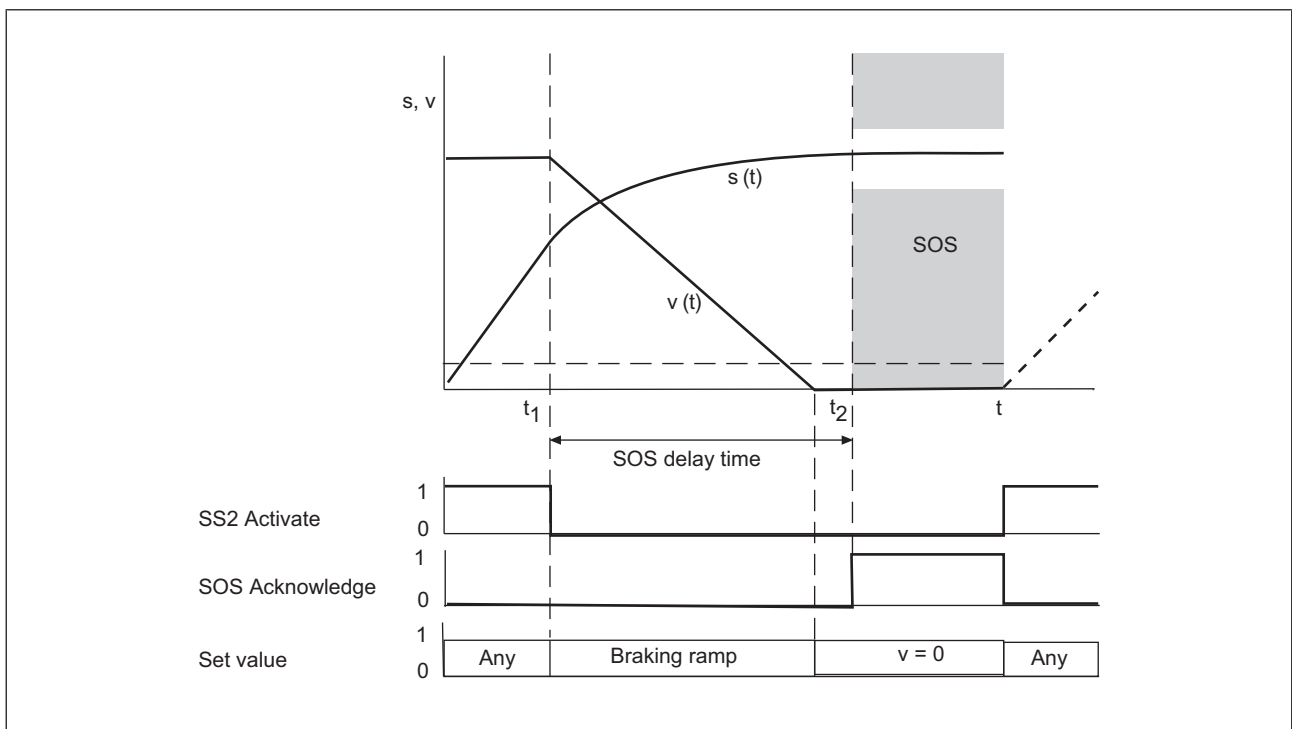

- ▶ SS2 Activate: Input for safety function SS2
- ▶ SOS Acknowledge: Output for feedback from safety function SOS
- ▶ Setpoint value: Specification of setpoint values



INFORMATION

Further information on the command can be found in the online help for the servo amplifier.

Please also refer to the operating manual for the servo amplifier.

4.5 Reaction times

The reaction times refer exclusively to the inputs and outputs on a servo amplifier with safety card when:

- ▶ The signal at the inputs changes
- ▶ The limit value is exceeded
- ▶ Internal errors are present

To determine the overall reaction times, the corresponding internal processing times in the servo amplifier, bus systems, periphery devices and controllers must also be taken into account.

Processing time of the digital input

The response and error reaction time takes into account the following processing times:

- ▶ Processing time of digital input T_{IN} : The time it takes for a "0" or "1" signal in the safety card to be detected once a signal has changed at the input. The processing time takes into account the input filter time, temperature drift, spread of components, etc.
- ▶ Internal processing times of the safety card
 - T_{CYCLE} : Scan time of the safety card's processor system
 - T_{OUT} : Processing time for the safety card's shutdown path
- ▶ T_{PULSE} : Processing time for the safe pulse disabler in the servo amplifier

Response time:

- ▶ The time it takes for the shutdown signal to be provided for the servo amplifier's power element, once a signal has changed at the input

$$T_{IN} + T_{CYCLE} + T_{OUT} + T_{PULSE}$$

Error reaction time:

- ▶ The time it takes for the shutdown signal to be provided for the servo amplifier's power element, once a limit value has been exceeded or an internal error has occurred.

$$T_{CYCLE} + T_{OUT} + T_{PULSE}$$

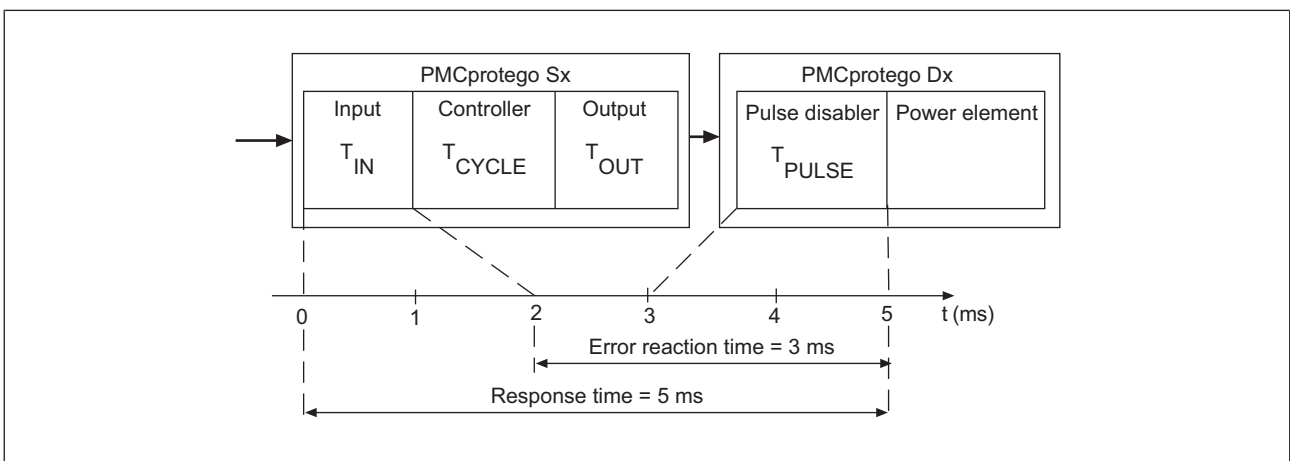

4.6 Configuration

The safety functions to be carried out by the safety card are defined in the safety card's configurator:

- ▶ Configuration of the safety functions
- ▶ Setting of limit values, braking ramps for the safety functions, monitoring of motion sequences

Download configuration:

- ▶ On single-axis systems, via the RS232 interface on the servo amplifier
- ▶ On networked systems, via the RS232 or Ethernet interface on the motion control system. The control system passes the configuration to the respective safety card.

Download of the configuration to the safety card:

- ▶ Online from configurator to safety card.
- ▶ Save configuration to external SD card.
- ▶ Order and serial numbers must be entered in the configuration to ensure the safety card is addressed securely.
- ▶ The feasibility of the configuration is checked when it is downloaded.
- ▶ Enabling of the power element after download depends on the status of the inputs on the safety card.

Upload configuration from safety card:

- ▶ Online from safety card to configurator
- ▶ Save safety card configuration to SD card in the servo amplifier.
- ▶ The feasibility of the configuration is checked as it is uploaded.



INFORMATION

Further information on the configuration and parameter settings for the safety functions is available in the safety card configurator's online help.

5 Installation

5.1 General requirements

Please also refer to the operating manual for the servo amplifier.



CAUTION!

Damage due to electrostatic discharge!

Electrostatic discharge can damage components. Ensure discharge before touching the safety card, e.g. by touching an earthed, conductive surface or by wearing an earthed armband.

5.2 Dimensions

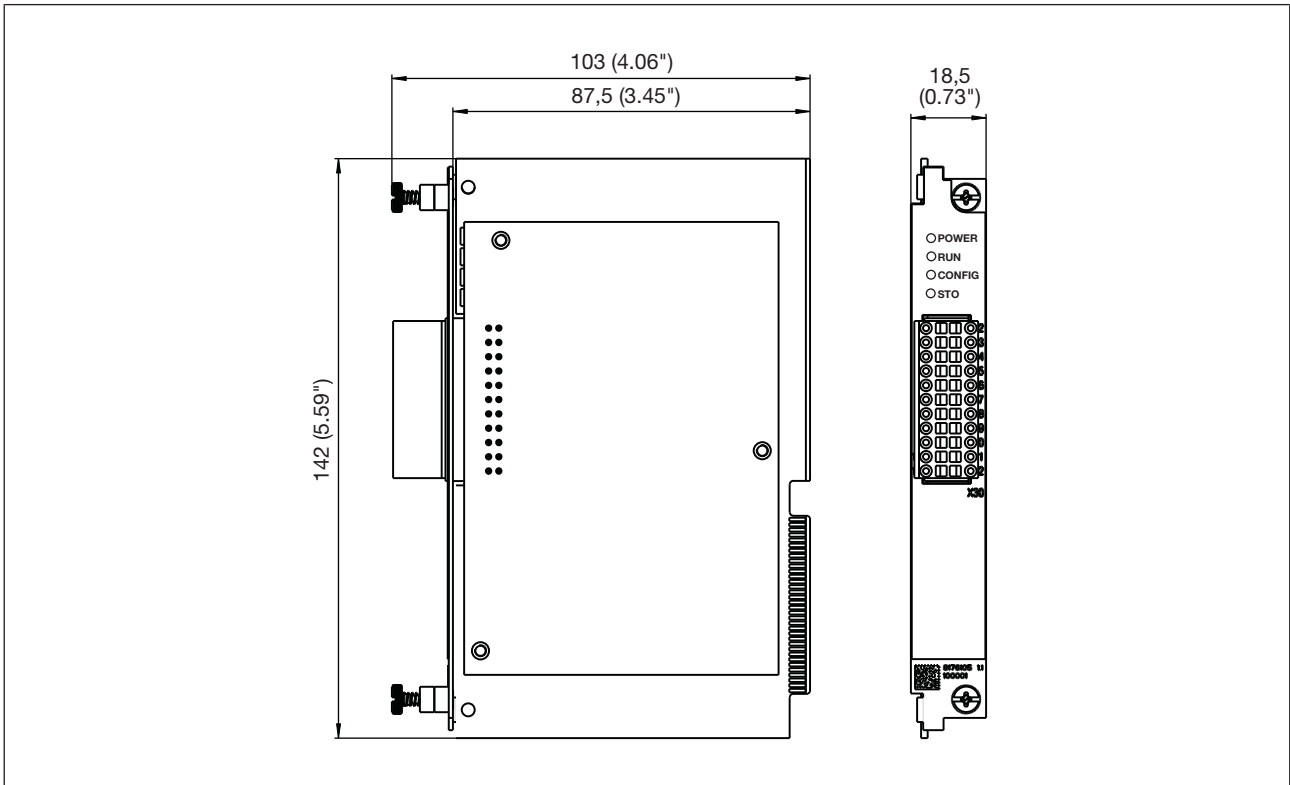







Fig.: Dimensions stated in mm (")

5.3 Installing the safety card

The expansion card is installed in slot 3 of the servo amplifier. When installing, please note the guidelines given under "Installation" in the operating manual for the servo amplifier.

		
<p>1. Remove the film.</p>	<p>2. Break the middle link</p>	<p>3. Break the top link and lever out the cover plate</p>
		
<p>4. Using suitable pliers, pull out the blank in the safety card plug</p>	<p>5. Plug in the safety card and tighten the screws</p>	

6 Wiring

6.1 General wiring guidelines

Inputs

- ▶ Appropriate wiring must be used to exclude short circuits between the inputs or to a supply line!
- ▶ Signal lines must be shielded.

Outputs

- ▶ If short circuits occur between the cable from the output to the load and a supply line, it will no longer be possible to switch off the load.
Possible remedy: Exclude the error by using separate multicore cable for supply voltages
- ▶ Use appropriate wiring to exclude short circuits between the outputs!
- ▶ Signal lines must be shielded.
- ▶ The outputs do not need suppression for inductive loads.

Cable material

- ▶ Use copper wiring.

Please note:

- ▶ Cable cross sections for field connection terminals in mm²:
 - Digital inputs/outputs, supply voltage: 0.5 (AWG20), crimp connectors with plastic collar in accordance with DIN 46228/4 0.5 mm² [H 0.5/16D] metrical. Ferrule length 10 mm, stripping length 12 mm
- ▶ Max. cable lengths
 - Supply voltage: Max. 30 m
 - Digital inputs and outputs: Max. 30 m
- ▶ To prevent EMC interferences (particularly common-mode interferences) the measures described in EN 60204-1 must be executed. This includes the separate routing of cables of the control circuits (input, start and feedback loop) from other cables for energy transmission or the shielding of cables, for example.

6.2 Connector pin assignment

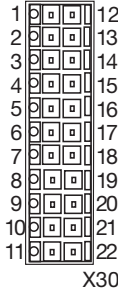
X30	Pin	Designation	Description
	1	SS1 Activate	Activate safety function SS1
	2	I0	Activate safety function
	3	I1	Activate safety function
	4	I2	Activate safety function
	5	STO Acknowledge	Status: STO
	6	O0	Status: Safety function activated
	7	O1	Status: Safety function activated
	8	O2	Status: Safety function activated
	9	O3	Status: Safety function activated
	10	24 V Supply	Supply voltage for digital outputs (24 VDC)
	11	n. c.	Not assigned
	12	I3	Activate safety function
	13	I4	Activate safety function
	14	I5	Activate safety function
	15	I6	Activate safety function
	16	Ready	Status: Safety card ready for operation and second output for feedback from safety function STO
	17	n. c.	Not connected
	18	n. c.	Not connected
	19	n. c.	Not connected
	20	Reset	Input for reset
	21	0 V Supply	Supply voltage for digital outputs (0 DC)
	22	0 V Supply	Supply voltage for digital outputs (0 DC)

6.3 Shielding

For immunity reasons, the signal lines for the digital inputs and outputs must be shielded:

- ▶ All shielded cables are to be attached at both ends to the shield terminals provided.
- ▶ Use cables with a braided shield, with a minimum coverage of 80 %.
- ▶ Any interruptions to the shielding e.g. at terminals, should be bridged at low impedance over a wide area.

The shields for the digital inputs and outputs should be connected to the front of the servo amplifier, as shown in the diagram below.

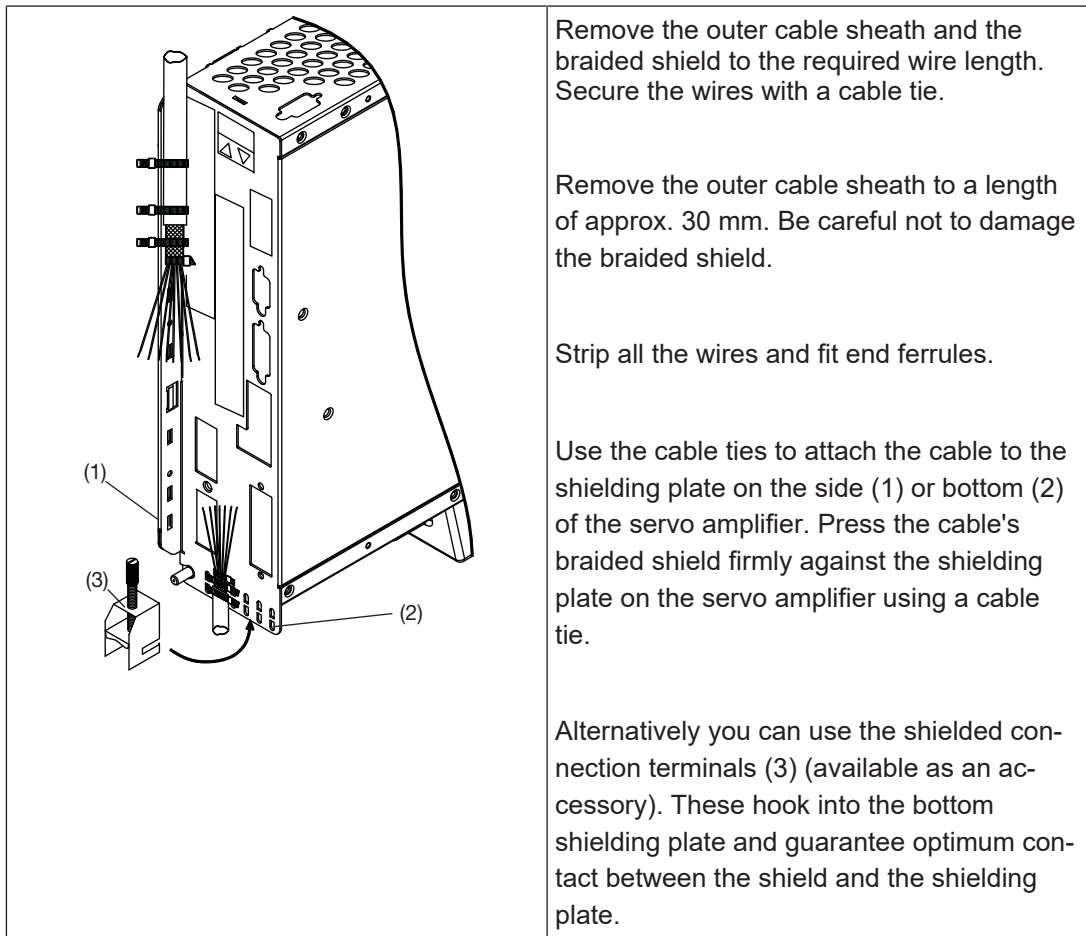

6.4 Digital inputs

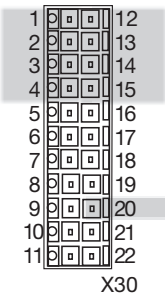
Connector X30	Pin	Designation	Description	
 <p>X30</p>	1	SS1 Activate	Activate safety function SS1	
	2	I0	Activate safety function	
	3	I1	Activate safety function	
	4	I2	Activate safety function	
	12	I3	Activate safety function	
	13	I4	Activate safety function	
	14	I5	Activate safety function	
	15	I6	Activate safety function	
	20	Reset	Input for reset	

Connector pin assignment

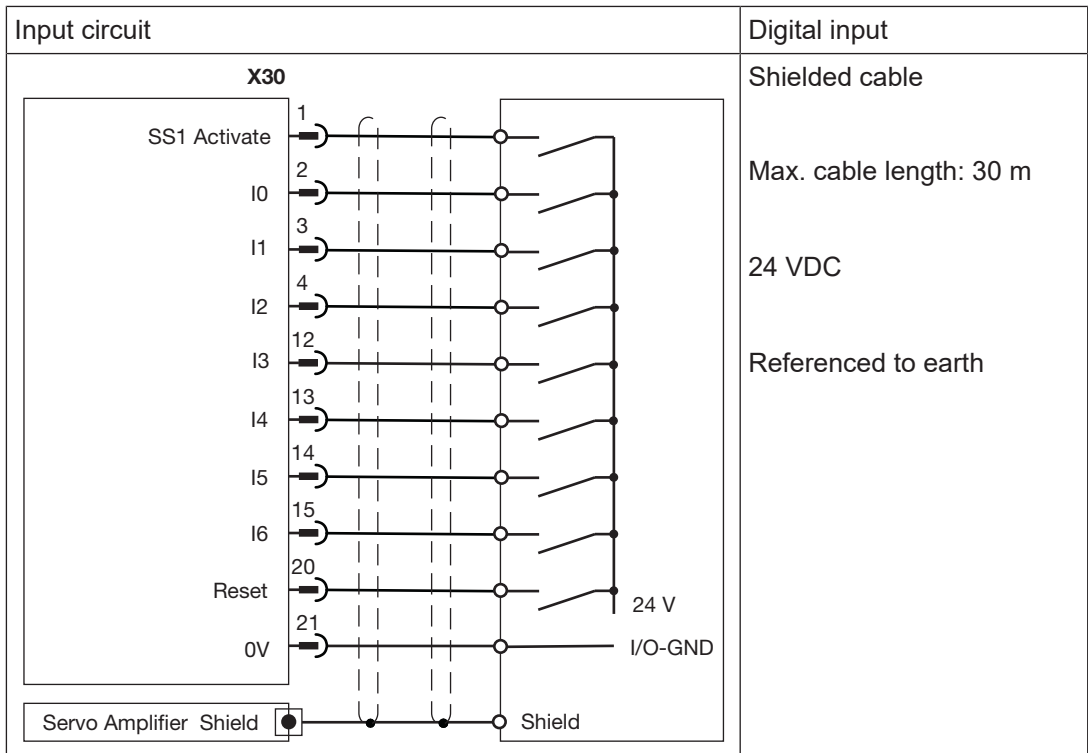

Connection

6.5 Digital outputs

6.5.1 Supply voltage

The digital outputs need a 24 VDC supply.

- ▶ When selecting the power supply, please refer to the requirements stated under “Technical Details”.
- ▶ The power supply must be able to bridge a power outage of 20 ms.



WARNING!

Electric shock!

Safe electrical isolation must be ensured for the external power supply that generates the supply voltage. Failure to do so could result in electric shock. The power supplies must comply with EN 62368-1, EN 61558-2-6, 08:2009.

Connector X30	Pin	Name	Description
<p style="text-align: center;">X30</p>	10	24 V Supply	Supply voltage for digital outputs (24 V)
	21, 22	0 V Supply	Supply voltage for digital outputs (0 V)
	Pins 21 and 22 are linked internally		

Connector pin assignment

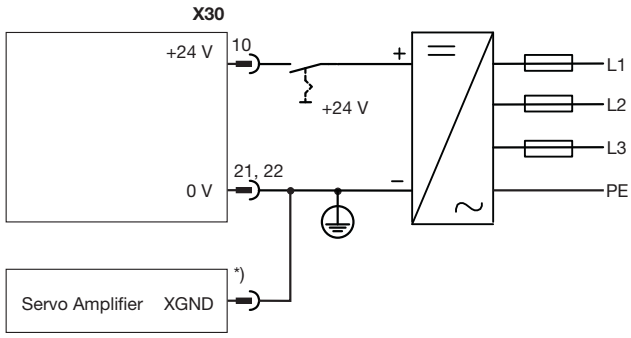
Supply voltage	
	<p>Max. cable length: 30 m</p> <p>24 V connection isolated from external power supply, e.g. with isolating transformer</p> <p>Noise suppression filter integrated within the safety card</p> <p>*) Please note the following:</p> <p>Link X30, Pin 21 or 22 to XGND on the servo amplifier</p>

Connection

*) XGND:

- ▶ PMCprotego D.01 ... D.24:
X4A, Pin 2
- ▶ PMCprotego D.48/D.72:
X4, Pin 3

6.5.2 Single-pole outputs

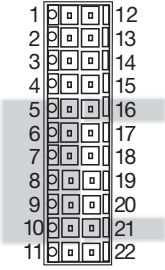
Connector X30	Pin	Designation	Description
 <p style="text-align: center;">X30</p>	5	STO Acknowledge	Status: STO activated
	6	O0	Status: Safety function activated
	7	O1	Status: Safety function activated
	8	O2	Status: Safety function activated
	9	O3	Status: Safety function activated
	10	24 V Supply	Supply voltage for digital outputs (24 V)
	16	Ready	Status: Safety card ready for operation and second output for feedback from safety function STO
21	0 V Supply	Supply voltage for digital outputs (0 V)	

Connector pin assignment

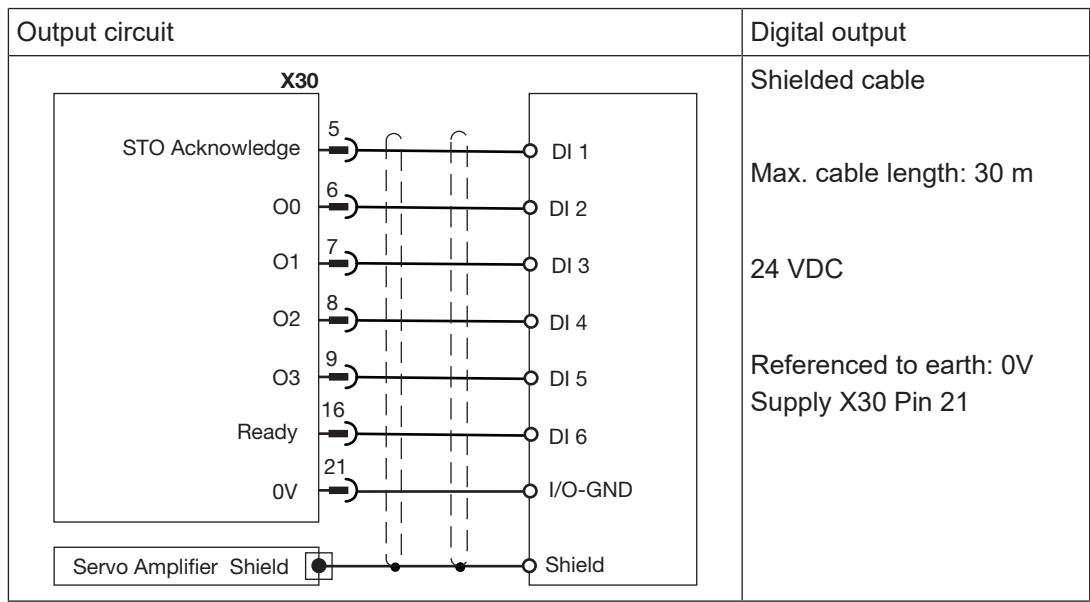

Connection

7 Commissioning

7.1 Safety guidelines

When commissioning/recommissioning, please note the following:

- ▶ Secure the site in accordance with the regulations (barrier, warning signs etc.). The system may only be commissioned/recommissioned by qualified personnel.
- ▶ Please refer to the information and specifications stated in the operating manual of the relevant programmable control system.
- ▶ During commissioning/recommissioning, make sure that no personal injury and/or material damage can occur, even if the plant/machine moves unintentionally.
- ▶ When commissioning the safety card, please read the safety guidelines in the "Commissioning" chapter in the instructions for the servo amplifier.



DANGER!

Risk of electrocution!

Never wire the electrical connections on the servo amplifier while voltage is applied.

Switch off the mains voltages and 24 V supply!

Make sure that the control cabinet is made safe, e.g. through an access lock or warning signs. Do not switch on the voltages until the system is commissioned!



WARNING!

Risk to life from the automatic start-up of the motor!

The motor can be set in motion immediately if the option "Set software enable when booting [AENA]" is set in the commissioning software PASconfig SDrive:

- after the safety card has run-up
- when recommissioning after a fault

Appropriate measures should be taken so that the start of the machine does not create a hazardous situation.

7.2 Initial commissioning

1. Preparing for commissioning

- ▶ The safety card has been properly configured in the Configurator.

Please ensure that you only configure the safety functions that are actually wired up to the safety card inputs.



INFORMATION

When configuring the safety card, please refer to the Configurator's online help.

- ▶ The safety card is installed on the servo amplifier (See "Installation" chapter).
- ▶ The device number (serial number and order number) of the safety card on the servo amplifier matches the device number of the safety card in the Configurator.
- ▶ The servo amplifier is ready for commissioning (see operating manual for the servo amplifier).

2. Wire up the safety card



INFORMATION

Please note the guidelines given under "Wiring".

- ▶ Connect the 24 VDC supply voltage ("+" to X30/10, "-" to X30/21)



INFORMATION

Do not switch on the supply voltage at this point.

- ▶ Wire up the inputs and outputs that have been configured. Please note that the inputs "SS1 Activate" and "Reset" must always be connected.

3. Connect the configuration PC to the servo amplifier or motion control system

- ▶ Connect the PC to the servo amplifier or motion control system (RS 232 or Ethernet).
- ▶ Set the interface in the Configurator (see the Configurator's online help).

4. Switch on the supply voltages

- ▶ Switch on all the supply voltages for the servo amplifier and safety card.

You will know when the servo amplifier and safety card are ready for operation by the display elements on the individual components. The display elements on the safety card are described in this manual, under "Operation".



INFORMATION

Up to twenty seconds may elapse before the safety card is ready for operation.

5. Download configuration file

- ▶ Establish communication between the PC and servo amplifier:

Select **Download Project** in the Configurator.

- Make sure that no other system is accessing the interface.
- To perform the download you will need to enter the safety cards' order and serial numbers for identification purposes.
- On multi-axis systems the safety cards can be selected individually for the download. The configuration is distributed to the safety cards via the motion control system.

The configuration file is downloaded. The "CONFIG" LED flashes.

The configuration is checked as it is downloaded:

- ▶ Feasibility of the configuration data
- ▶ Proper wiring
- ▶ Correct device number (order number and serial number)



INFORMATION

In the STARTUP state, a complete self test of the system is carried out. During this time, the system is not ready for operation. The "Ready" output and all freely configurable outputs (O0 ... O3) have a "0 signal" in the STARTUP phase.

If the self test is successful, the servo amplifier's power element is enabled. The "Ready" output has a "1" signal. The "RUN" LED is lit.

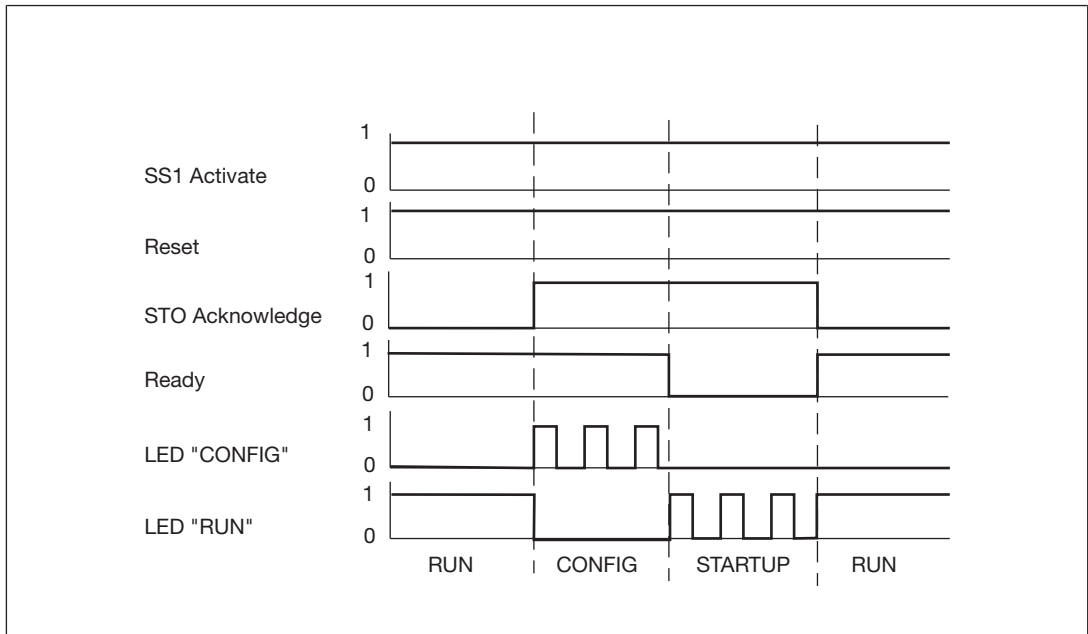

- ▶ SS1 Activate: Input for safety function SS1
- ▶ Reset: Input for reset
- ▶ STO Acknowledge: Output for feedback from safety function STO
- ▶ Ready: Output for operating status of the safety card
- ▶ "CONFIG" LED: Downloading the configuration data
- ▶ "RUN" LED: System is ready
- ▶ RUN: System is ready for operation
- ▶ CONFIG: Downloading the configuration data
- ▶ STARTUP: System starts up with the downloaded configuration

The inputs and outputs on the safety card can be tested using

- ▶ The dynamic program display in the safety card's Configurator
- ▶ the commissioning software PASmotion



INFORMATION

Please note the following in the STARTUP state:
 The activation inputs of all the safety functions configured in the tool must be switched to +24 VDC.

7.3 Recommissioning

7.3.1 Recommissioning at a restart

The timing diagram below illustrates the signal sequence of the servo amplifier and safety card at a restart. The safety card has already been configured (see "Initial commissioning")

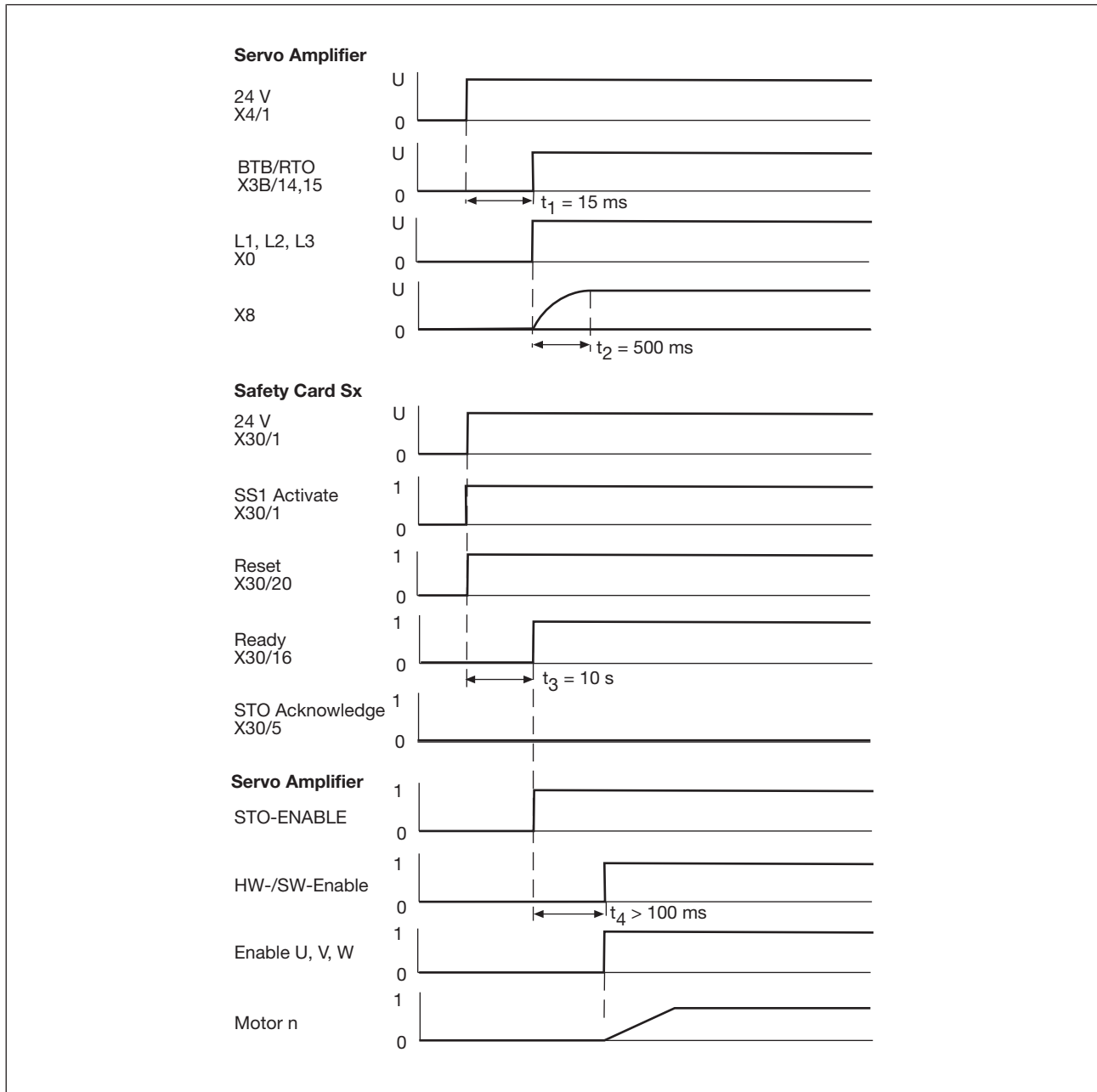

Legend:

- ▶ Servo amplifier
 - 24 V: Supply voltage
 - BTB/RTO: Relay contact for operational readiness, servo amplifier
 - L1, L2, L3: Mains voltage
 - X8: Intermediate circuit

- STO-ENABLE: start interlock
- HW-/SW-Enable: Hardware and software enable
- Enable U, V, W: Motor connection
- Motor n: Motor speed
- t_1 : Servo amplifier's run-up time
- t_2 : Load time, intermediate circuit capacitance
- t_4 : Processing time until servo amplifier is enabled

▶ Safety Card

- 24 V: Supply voltage
- SS1 Activate: SS1 activated
- Reset: Input for reset
- Ready: Operational readiness
- STO Acknowledge: Status: STO activated
- t_3 : Safety card's run-up time



INFORMATION

Please note the following in the STARTUP state:
The activation inputs of all the safety functions configured in the tool must be switched to +24 VDC.

7.3.2 Recommissioning after error

This section describes the recommissioning process after an error has occurred.

Rectify the error, noting:

- ▶ The error messages in the error stack
- ▶ The LED display.

Perform a reset as follows:

- ▶ Switch the inputs "SS1 Activate" or "Reset"
- or
- ▶ Run the command "CLRFAULT"



INFORMATION

Please note the following in the STARTUP state:
The activation inputs of all the safety functions configured in the tool must be switched to +24 VDC.

7.3.2.1 Switching the inputs "SS1 Activate" or "Reset"

1. Switch input "SS1 Activate" or "Reset" to 0 V
 - ▶ The safety card performs the safety function SS1 (Safe Stop 1) and switches to a "STOP" condition. The "STO" LED flashes.
2. Switch input "SS1 Activate" and "Reset" to 24 V.
 - ▶ The safety card switches to a "STARTUP" condition. The device and the safe pulse disabler are tested. The "RUN" LED flashes.
 - ▶ The safety card switches to a "RUN" condition. The "RUN" LED is lit continuously.

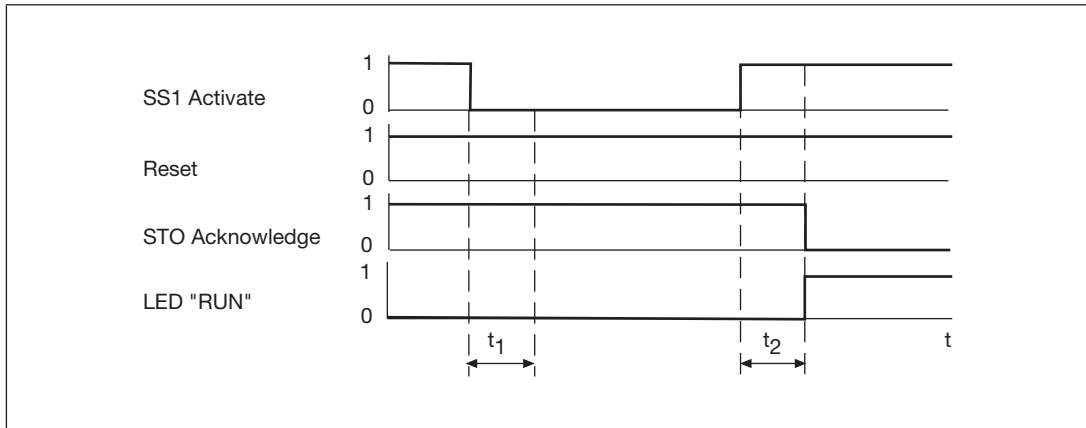

- ▶ t_1 : At least 2 ms; time during which SS1 Activate or Reset must have a "0" signal
- ▶ t_2 : Approx. 2 s, safety card's run-up time
- ▶ SS1 Activate: Input for safety function SS1
- ▶ Reset: Input for reset
- ▶ STO Acknowledge: Output for feedback from safety function STO
- ▶ "RUN" LED: System is ready

7.3.2.2 Command "CLRFAULT"

The safety card can be reset using the "CLRFAULT" command via the serial interface or fieldbus interface on the servo amplifier.

Prerequisites for using the "CLRFAULT" command

- ▶ The safety card is in "STOP" condition. The "STO" LED flashes.
- ▶ Both inputs SS1 Activate and Reset have a "1" signal (24 V).

Alternatively this function can also be assigned to a digital input on the servo amplifier. Two commands are available:

- ▶ The command `IN1MODE=1`, (servo amplifier error reset), activates the function on digital input DIGITAL-IN1 of the servo amplifier.
- ▶ The commands `INxMODE=30` or `INxMODE=33` (run any command string) activate the function on one of the digital inputs on the servo amplifier (e.g. `IN4MODE=30` on input DIGITAL-IN4).

**INFORMATION**

Further information on the command can be found in the online help for the servo amplifier.

Please also refer to the operating manual for the servo amplifier.

**INFORMATION**

Availability of this function: From firmware version 5.24 of the servo amplifier.

7.3.3**Swap safety card**

When swapping the safety card, please note the following:

- ▶ If the firmware version has changed, configured functions and stated parameters may no longer be supported or may have been modified. Adapt the configuration in the Configurator PASconfig SDrive.
- ▶ You will need to download the configuration to the safety card again. Please note down the serial number of the new safety card.
- ▶ We recommend that you swap the whole unit (servo amplifier with safety card). Please contact Pilz.

**NOTICE**

Damage due to electrostatic discharge!

Electrostatic discharge can damage components. Ensure against discharge before touching the product, e.g. by touching an earthed, conductive surface or by wearing an earthed armband.

After swapping the safety card, following a defect for example, you will need to download the configuration data to the safety card again.

You can download the configuration data to the safety card as follows:

- ▶ ① From the Configurator to the safety card via the servo amplifier's communications interface (RS 232 or Ethernet).
- ▶ ④ From an SD card in the servo amplifier to the safety card.

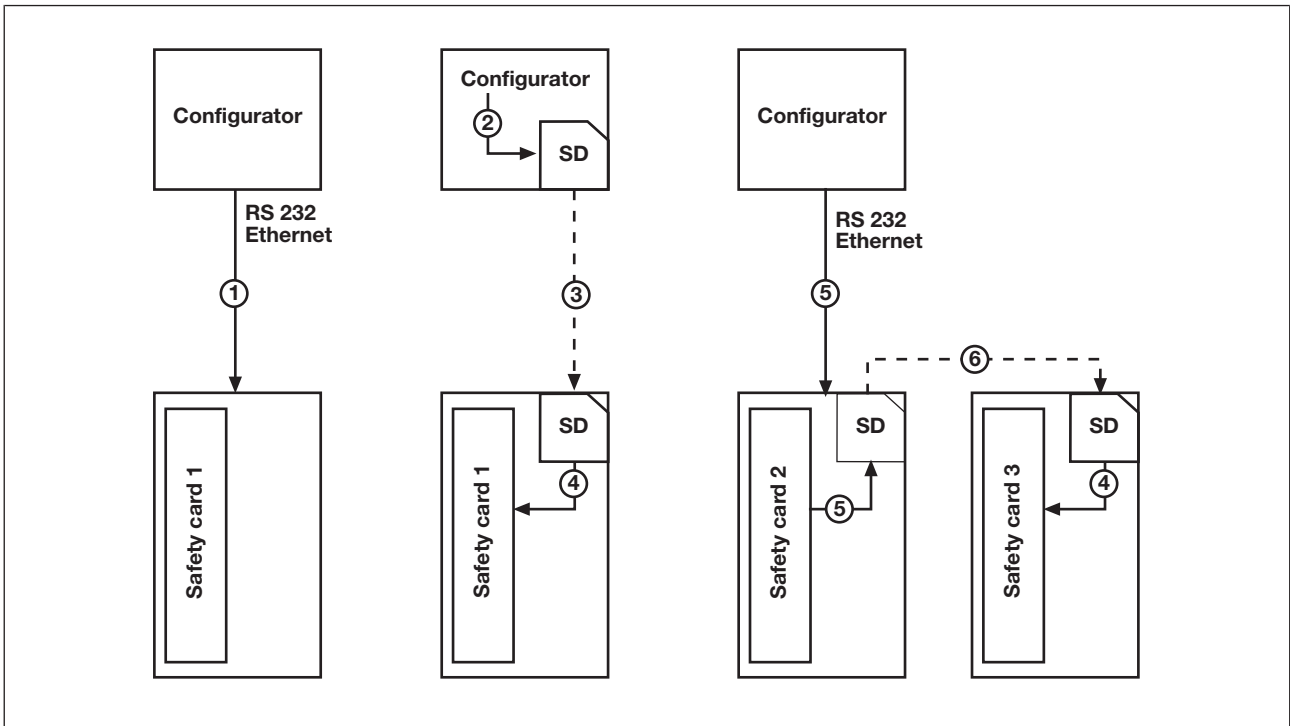

Fig.: Download configuration

Legend:

- ① Downloading a configuration from the Configurator directly to safety card 1
- ② Downloading a configuration via an SD card, which is written by the PC
- ③ Inserting an SD card into the read device of the servo amplifier for safety card 1
- ④ Downloading a configuration to the safety card from an SD card in the servo amplifier
- ⑤ Downloading a configuration via an SD card, which is written by the servo amplifier (safety card 2)
- ⑥ Inserting an SD card from the servo amplifier for safety card 2 into the read device of the servo amplifier for safety card 3

7.3.3.1 Download configuration from Configurator to safety card

① The configuration data on the safety card can be downloaded directly from the Configurator to the safety card in the servo amplifier.

Prerequisite:

- ▶ Connection is established between the PC and servo amplifier (RS 232 or Ethernet).

Procedure:

- ▶ Select *Online Mode* -> *Download Project* in the safety card's Configurator.



INFORMATION

Further information is available in the safety card Configurator's online help.

7.3.3.2 Download configuration to SD card

② ⑤ You can download the configuration data to the safety card via an SD card. The configuration data must first be saved to the SD card.

There are two options for downloading a configuration to an SD card:

1. option ②: Downloading a configuration via an SD card, which is written by the PC.

Prerequisite:

⇒ Connection to an external SD card read device

Procedure:

- Select *Project -> Save to SD Card* in the safety card's Configurator.
- Remove the SD card from the external SD card read device and insert it into the servo amplifier's SD card read device ③ (continue as described under "Download configuration from SD card to safety card").

2. option ⑤: Downloading a configuration via an SD card, which is written by the servo amplifier.

Prerequisite

- Connection is established between the PC and servo amplifier (RS 232 or Ethernet).
- An SD card must be inserted in the servo amplifier.

Procedure:

- Select *Online Mode -> Servo Amplifier Configuration -> SD Card* in the safety card's Configurator.
- Remove the SD card from the servo amplifier and insert it into the SD card read device of the servo amplifier that you wish to configure ⑥ (continue as described under "Download configuration from SD card to safety card").



INFORMATION

Further information is available in the safety card Configurator's online help.

7.3.3.3 Download configuration from SD card to safety card

Before carrying out the steps described in this section, please note the following safety guidelines:

**CAUTION!**

Make absolutely sure that the SD card with the safety card configuration is inserted into the read device of the correct servo amplifier. If not, invalid parameter settings (e.g. limit values) may lead to unexpected movements and hazardous situations for either people or equipment.

When the configuration is downloaded from the SD card, the servo amplifier does not check the safety card configuration, nor does it check that the configuration is assigned correctly to a specific safety card.

After swapping the safety card, check that the safety functions are activated correctly.





④ The safety card's configuration data can be downloaded to the safety card from an SD card inserted in the servo amplifier, without using the Configurator.

During this process, the firmware for the servo amplifier is also reloaded.

Prerequisite:

- ▶ The following files must be available on the SD card (③ or ⑥):
 - default.pdis: Configuration file for the safety card
 - default.bin or default.s19: Firmware for the servo amplifier
 - default.par: Parameter file for the servo amplifier

Procedure:

1. **Switch off the 24 V supply to the servo amplifier.**
2. **Insert the SD card into the read device in the servo amplifier.**
3. **Keep both operator keys   on the servo amplifier pressed down.**
4. **Switch on the 24 V supply to the servo amplifier.**
5. **Release the keys when "-" appears on the display.**
6. **Press both operator keys   again and then release them.**
 - The firmware update for the servo amplifier is started.
 - The file default.bin or default.s19 is loaded.
 - Display: Counts from 0 to 100, stops at 100 and then counts from 100 to 0.
 - The servo amplifier is restarted. The parameter file default.par is loaded.
 - The safety card is restarted: The "CONFIG" LED flashes.
7. **Wait until "dis" (= drive integrated safety) appears on the display.**
 - ⇒ Note: You must then press the left-hand operator key on the servo amplifier within 60 seconds (see step 8).
8. **Press the left-hand operator key  for at least 2 seconds.**

- The configuration file default.pdis starts downloading to the safety card. Display: "...".
- Once the configuration file has been downloaded, the safety card starts up. The safety card is in "STARTUP" condition ("RUN" LED flashes).
- If the download has been successful, the safety card switches to "RUN" condition ("RUN" LED is lit).

7.4 Safety checks

The machine manufacturer must check and verify the functionality of the employed safety functions.

- ▶ The safety function may only be checked by qualified personnel.

The safety function must be checked

- ▶ After initial commissioning
- ▶ After changing the configuration of the safety functions
- ▶ After exchanging the safety card or servo amplifier
- ▶ After changing the configuration of the servo amplifier (for example when changing the motor type, motor encoder type or brake selection)

A full check comprises

- ▶ proper execution of the safety functions used of the safety card PMCprotego S
- ▶ proper execution of the overall safety function (e.g. combination and integration of safety functions)
- ▶ Inspection of the parameters

The basis for testing

- ▶ are the requirements for the safety functions of the safety card PMCprotego S resulting from the risk analysis of the machine or process
- ▶ is the description of the safety card PMCprotego S and its safety functions in accordance with this operating manual
- ▶ are all safety-related parameters and values of the safety functions used

The result of the test must be documented in a test report. This report must contain the following:

- ▶ a description of the application, including a diagram
- ▶ a description of the safety-related components (including software versions) used by the application
- ▶ a list of the safety functions used
- ▶ the results of all tests related to these safety functions
- ▶ a list of all safety-related parameters and their values
- ▶ check sums, test dates and confirmation by the test staff

Safety tests conducted on equivalent applications may be carried out as an individual type test of the equivalent application, provided that it can be ensured that the safety functions are configured as intended for all devices.



INFORMATION

If any of the parameters for the safety functions have been changed, the check must be repeated and this must be recorded in the test report.

8 Operation

Prerequisites for normal operation are:

- ▶ Commissioning is complete
- ▶ The safety card contains the configuration data
- ▶ The safety functions have been tested
- ▶ The "RUN" LED is lit

During operation

- ▶ Any pulse edge change at the safety card's safe inputs is monitored
- ▶ The safety functions are performed in accordance with the configuration.

8.1 Operating states

The safety card is always in clearly defined operating states.

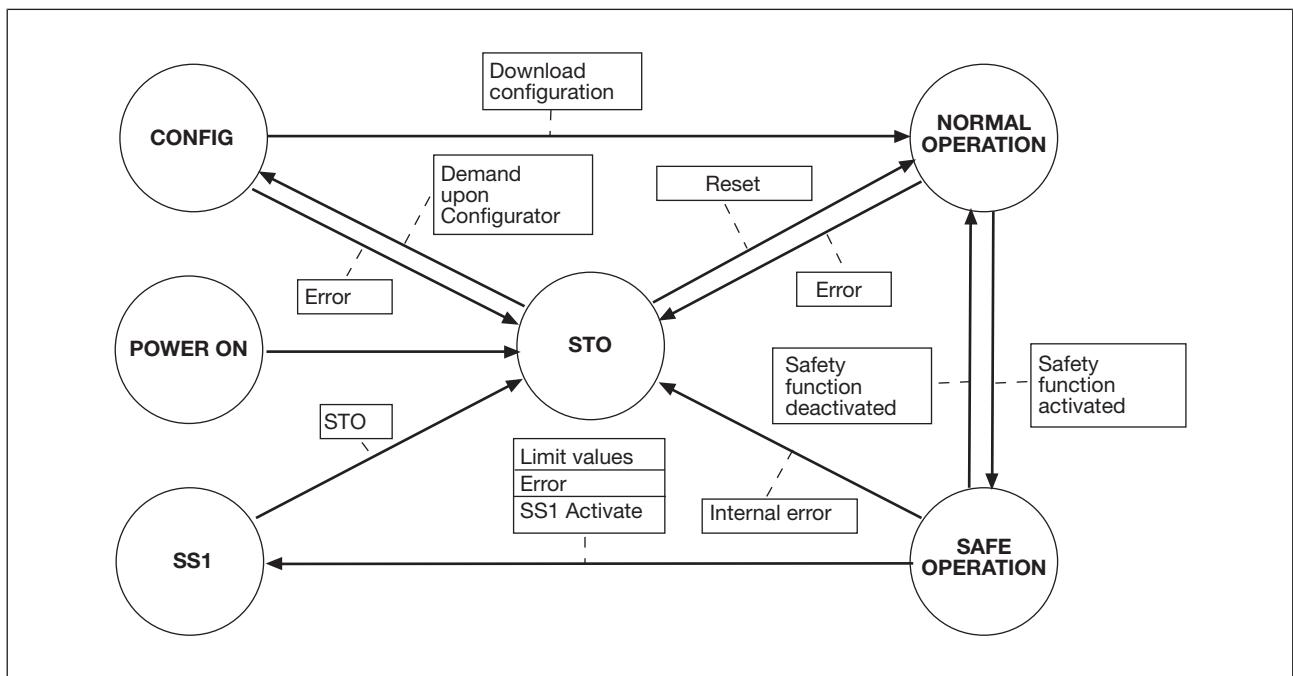

POWER ON

- ▶ The supply voltages are present.
- ▶ Transition to STO once the supply voltages are applied

CONFIG

- ▶ Download of configuration to the safety card
- ▶ Transition to state of NORMAL OPERATION: Configuration downloaded without error
- ▶ Transition to state of STO: Incorrect configuration data
- ▶ The motor is switched volt free in the CONFIG operating state (STO is active)

NORMAL OPERATION

- ▶ No safety function activated
- ▶ Transition to state of STO: Internal error
- ▶ Transition to SAFE OPERATION: A safety function is activated

SAFE OPERATION

- ▶ Safe operation after at least one safety function has been activated
- ▶ Transition to STO: Internal error
- ▶ Transition to SS1 due to
 - Error
 - Violation of limit values
 - Demand upon safety function SS1
- ▶ Transition to NORMAL OPERATION: No safety function activated

SS1

- ▶ SS1 is activated
 - After violation of the limit values
 - After an error
 - After a demand upon safety function SS1
- ▶ Transition to STO: After activation of SS1 (drive is brought to a standstill with a defined braking ramp)

STO

- ▶ There is no power to the motor after execution of safety function STO
- ▶ Transition to CONFIG: Demand upon the Configurator
- ▶ Transition to NORMAL OPERATION due to
 - Reset of safety card (see "Recommissioning")
 - Prior POWER ON

8.2 Testing the safe pulse disabler

The safety card meets the requirements of EN IEC 61508 up to SIL 2 and EN ISO 13849-1 up to PL d.

The function of the safe pulse disabler is tested

- ▶ By restarting after safety functions SS1 or STO have been triggered as a condition of operation
- or
- ▶ By restarting after safety function SS1 has been triggered by the operator

To test the safe pulse disabler, proceed as follows:

1. Switch input "SS1 Activate" or "Reset" to 0 V
 - ▶ The safety card performs the safety function SS1 (Safe Stop 1) and switches to a "STOP" condition. The "STO" LED flashes.
2. Switch input "SS1 Activate" and "Reset" to 24 V.
 - ▶ The safety card switches to a "STARTUP" condition. The device and the safe pulse disabler are tested. The "RUN" LED flashes.
 - ▶ The safety card switches to a "RUN" condition. The "RUN" LED is lit continuously.

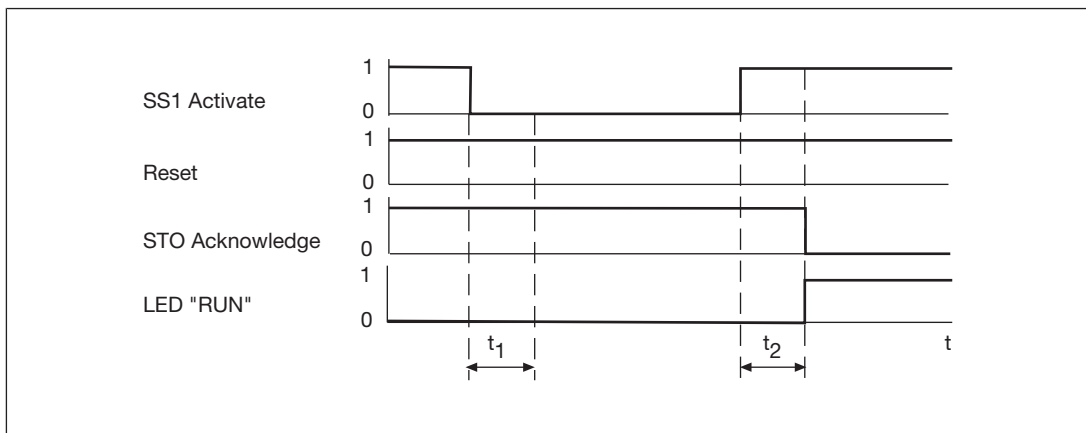

- ▶ t_1 : At least 2 ms; time during which SS1 Activate or Reset must have a "0" signal
- ▶ t_2 : Approx. 2 s, safety card's run-up time
- ▶ SS1 Activate: Input for safety function SS1
- ▶ Reset: Input for reset
- ▶ STO Acknowledge: Output for feedback from safety function STO
- ▶ "RUN" LED: System is ready

8.3 Display elements

The expansion card has LEDs to display the status of the operating states.

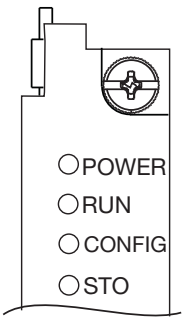
	LED			Meaning
	Name	Colour	Status	
	POWER	---	●	Supply voltage is not present
		Green	☀	Supply voltage is present
	RUN	---	●	System not ready
		Green	☀	System ready ("RUN" status)
		Green	◐	System boots ("Start-up" status)
	CONFIG	---	●	Normal operation
		Yellow	◐	Downloading the configuration data
	STO	---	●	No error occurred, safety function SS1 not triggered, operating status STO is inactive
Red		◐	Error occurred or safety function SS1 triggered, operating status STO is active	

► Legend

☀	LED on
●	LED off
◐	LED flashes

8.4 Messages

Any errors on the safety card are indicated on the servo amplifier display with message "F31".

The following options are available for detailed diagnostics and fault detection:

- ▶ LEDs on the front of the safety card provide information on operating states (see section on "Display elements" in this chapter).
- ▶ Outputs on the safety card display the state of the safety functions (e.g. STO Acknowledge).
- ▶ Errors and messages are entered in the safety card's error stack.
- ▶ The following are displayed in online mode in the Configurator PASconfig SDrive:
 - Safety card status messages and error messages (error stack)
 - States of safety card inputs and outputs
- ▶ The expanded diagnostics system PVIS displays errors, messages and the corresponding remedies only in conjunction with a PMCprimo controller.

8.5 Diagnostic tests

- ▶ The safety card has a dual-channel structure with internal diagnostic tests, thus no external safety system is required to achieve safety.
- ▶ The test functions for the hardware inputs and outputs are described in the chapter [Inputs and outputs](#) [ 15].

9 Change, maintenance, decommissioning

9.1 Change

It may be necessary to change a process/machine because:

- ▶ A safety requirement has changed
- ▶ A systematic fault has occurred
- ▶ There are new operational or production requirements
- ▶ The process cycle/machine has changed

Before changing a safe process/safe machine, a preparatory analysis must be carried out. The following effects must be analysed:

- ▶ How the changes will affect the safety of the process/machine
- ▶ How the changes will affect the safety functions of the safety card

The change requirements can be combined in a catalogue of requirements. This should include:

- ▶ Detected hazards
- ▶ Desired changes
- ▶ Reason for the changes

The change should only be carried out by persons with the necessary knowledge and experience (competent persons).



INFORMATION

- Note the information about assembly/disassembly in the operating manual for the servo amplifier.
- Following a change, if the safety analysis has shown that safety functions need to be validated and tested, the change itself must be tested, as must the course of the entire process. This must be taken into account for recommissioning.
- Please note the requirements for recommissioning after a change.



NOTICE

The check sums can be used to establish whether safety-related changes have been made and therefore whether safety functions need to be validated and tested. However, a comparison may only be used as an additional aid. Under no circumstances can it replace a prior safety analysis for the changes.

9.2 Maintenance

No maintenance work is necessary on a PMCprotego S safety card. Please return the safety card to Pilz.

9.3 Decommissioning

Note the mission time T_M stated in the safety-related characteristic data of the PMCprotego S safety card.

Note the information about assembly/disassembly in this operating manual.

When decommissioning, please comply with local regulations regarding the disposal of electronic devices (e.g. Electrical and Electronic Equipment Act).

10 Technical details

General	680006	680009
Certifications	CE, TÜV	CE, TÜV
Application range	Failsafe	Failsafe
Electrical data	680006	680009
Permitted loads	inductive, capacitive, resistive	inductive, capacitive, resistive
Inputs	680006	680009
Number	9	9
Signal level at "0"	-3 - +5 V DC	-3 - +5 V DC
Signal level at "1"	15 - 30 V DC	15 - 30 V DC
Input voltage in accordance with EN 61131-2 Type 1	24 V DC	24 V DC
Input current range	3,5 - 10,8 mA	3,5 - 10,8 mA
Pulse suppression	0,6 ms	0,6 ms
Semiconductor outputs	680006	680009
Number of positive-switching single-pole semiconductor outputs	6	6
External supply voltage	24 V	24 V
Voltage tolerance	-15 %/+20 %	-15 %/+20 %
Typ. output current at "1" signal and rated voltage of semiconductor output	0,5 A	0,5 A
Permitted current range	0,5 A	0,5 A
Residual current at "0" signal	0,02 mA	0,02 mA
Monitoring threshold of semiconductor output	7 V	7 V
Max. duration of on time during self test	200 µs	200 µs
Max. duration of off time during self test	200 µs	200 µs
Galvanic isolation	yes	yes
Short circuit-proof	yes	yes
Times	680006	680009
Response time	5 ms	5 ms
Error reaction time	3 ms	3 ms
Environmental data	680006	680009
Climatic suitability	EN 60068-2-1, EN 60068-2-14, EN 60068-2-2, EN 60068-2-30, EN 60068-2-78	EN 60068-2-1, EN 60068-2-14, EN 60068-2-2, EN 60068-2-30, EN 60068-2-78
Ambient temperature		
In accordance with the standard	DIN EN 60721-3-3	DIN EN 60721-3-3
Class	3K3	3K3
Temperature range	0 - 40 °C	0 - 40 °C

Environmental data	680006	680009
Storage temperature		
In accordance with the standard	DIN EN 60721-3-1	DIN EN 60721-3-1
Temperature range	-25 - 55 °C	-25 - 55 °C
Storage temperature class	1K4	1K4
Climatic suitability		
In accordance with the standard	DIN EN 60721-3-3	DIN EN 60721-3-3
Humidity	85 % r.h.	85 % r.h.
Relative humidity class	3K3	3K3
Condensation during operation	Not permitted	Not permitted
EMC	EN 61800-3	EN 61800-3
Vibration		
In accordance with the standard	EN 60721-3-2	EN 60721-3-2
Class	2M1	2M1
Airgap creepage		
In accordance with the standard	EN 61800-5-1	EN 61800-5-1
Overvoltage category	II	II
Pollution degree	2	2
Protection type		
In accordance with the standard	EN 60529	EN 60529
Housing	IP20	IP20
Terminals	IP20	IP20
Mounting area (e.g. control cabinet)	IP54	IP54
Mechanical data	680006	680009
Material		
Front	Steel 1.4016	Steel 1.4016
Top	Polyester film	Polyester film
Mounting type	plug-in	plug-in
Conductor cross section with screw terminals		
Rigid single-core, flexible multi-core or multi-core with crimp connector	1 mm²	1 mm²
Dimensions		
Height	142 mm	142 mm
Width	18,5 mm	18,5 mm
Depth	103 mm	103 mm
Weight	150 g	150 g

Where standards are undated, the 2021-03 latest editions shall apply.

10.1 Safety characteristic data

10.1.1 Safe actuator with one encoder

Please note the following fault detection guidelines:

When the drive is operated with an encoder (standard motor encoder on the servo amplifier), a fault on the encoder system is detected by the safety card as follows:

▶ **Rotary synchronous motors**

Detected within one mechanical revolution of the motor.

▶ **Linear synchronous motors**

Detected within the distance travelled, in accordance with the following formula:

Distance = (Number of poles / 2) · Pole pair pitch

Commands in the servo amplifier:

- Number of poles: MPOLES
- Pole pair pitch: MPITCH

10.1.1.1 MTTF >= 10 years

Operating mode	EN ISO 13849-1: 2015	EN ISO 13849-1: 2015	EN 62061 SIL CL	EN 62061 PFH _D [1/h]	IEC 61511 SIL	IEC 61511 PFD	EN ISO 13849-1: 2015 T _M [year]
	PL	Category					
Safe actuator	PL d	Cat. 3	SIL CL 2	1,35E-07	SIL 2	1,72E-03	20

This operating mode requires a motor encoder with MTTF ≥ 10 years.

The motor encoder is already included in the characteristic data, so no more calculations need to be performed for the "Safe Actuator" subsystem.

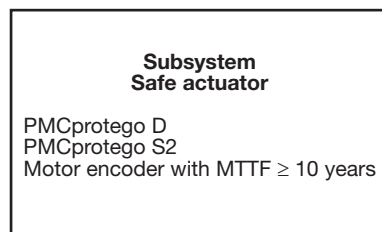

The safety-related characteristic data is valid for all safety functions.

All the units used within a safety function must be considered when calculating the safety characteristic data.

11 Order reference

Order reference		
Product type	Features	Order no.
PMCprotego S2-2	Safety Card	680006
PMCprotego S2-2-C	Safety card with coated circuit board	680009

Safe Direction (SDI)

Safety function in accordance with EN 61800-5-2: "The SDI function prevents the motor shaft from moving in an unintended direction."

Safe Operating Stop (SOS)

Safety function in accordance with EN 61800-5-2: "The SOS function prevents the motor from deviating from the stop position by more than a defined amount. The PDS(SR) (electrical power drive system) supplies power to the motor that enables it to withstand the engagement of external forces."

Safe Speed Range (SSR)

Safety function in accordance with EN 61800-5-2: "The SSR function holds the motor speed within defined limit values."

Safe Stop 1 (SS1)

Safety function in accordance with EN 61800-5-2: "The PDS(SR) performs one of these functions: a) Either initiates and controls the length of the motor delay within defined limits and initiates the STO function (see 4.2.2.2) if the motor speed falls below a defined limit value, or b) Initiates and monitors the length of the motor delay within defined limits and initiates the STO function if the motor speed drops below a defined limit value, or c) Initiates the motor delay and then initiates the STO function after an application-specific time delay."

Safe Stop 2 (SS2)

Safety function in accordance with EN 61800-5-2: "The PDS(SR) performs one of these functions: a) Either initiates and controls the length of the motor delay within defined limits and initiates the SOS function (see 4.2.3.1) if the motor speed falls below a defined limit value, or b) Initiates and monitors the length of the motor delay within defined limits and initiates the SOS function if the motor speed drops below a defined limit value, or c) Initiates the motor delay and then initiates the SOS function after an application-specific time delay."

Safe Torque Off (STO)

Stop function in accordance with EN 61800-5-2: "No power that can cause a rotation (or in the case of a linear motor, a movement) is supplied to the motor. The PDS(SR) (electrical power drive system) does not supply any power to the motor that can generate torque (or in the case of a linear motor, force)."

Safely Limited Increment (SLI)

Safety function in accordance with EN 61800-5-2: "The SLI function prevents the motor shaft from exceeding the specified limit of position increment."

Safely Limited Speed (SLS)

Safety function in accordance with EN 61800-5-2: "The SLS function prevents the motor from exceeding the specified speed limit."

