



## PMCprimo MC

**PILZ**  
THE SPIRIT OF SAFETY

► Control systems

This document is the original document.

Where unavoidable, for reasons of readability, the masculine form has been selected when formulating this document. We do assure you that all persons are regarded without discrimination and on an equal basis.

All rights to this documentation are reserved by Pilz GmbH & Co. KG. Copies may be made for the user's internal purposes. Suggestions and comments for improving this documentation will be gratefully received.

Pilz®, PIT®, PMI®, PNOZ®, Primo®, PSEN®, PSS®, PVIS®, SafetyBUS p®, SafetyEYE®, SafetyNET p®, the spirit of safety® are registered and protected trademarks of Pilz GmbH & Co. KG in some countries.



SD means Secure Digital

<b>1</b>	<b>Introduction</b> .....	<b>6</b>
1.1	Validity of documentation .....	6
1.2	Retaining the documentation .....	6
1.3	Definition of symbols .....	6
<b>2</b>	<b>Overview</b> .....	<b>8</b>
2.1	Unit features .....	8
2.2	Front view .....	9
2.3	Type code .....	10
2.4	Type label .....	11
2.5	Scope .....	11
<b>3</b>	<b>Safety</b> .....	<b>12</b>
3.1	Intended use .....	12
3.2	Safety regulations .....	12
3.2.1	Use of qualified personnel .....	12
3.2.2	Warranty and liability .....	13
3.2.3	Disposal .....	13
3.3	Standards .....	13
<b>4</b>	<b>Security</b> .....	<b>14</b>
4.1	Required security measures .....	14
<b>5</b>	<b>Function description</b> .....	<b>16</b>
5.1	Device properties .....	16
5.1.1	Controller .....	16
5.1.1.1	Networking with servo amplifier .....	17
5.1.2	Connecting the supply voltage .....	20
5.1.3	Digital inputs .....	21
5.1.4	Digital outputs .....	22
5.1.5	Interfaces .....	22
5.1.5.1	Overview .....	22
5.1.5.2	CANopen .....	23
5.1.5.3	PROFIBUS DP .....	24
5.1.5.4	Ethernet .....	24
5.1.5.5	EtherCAT .....	24
5.1.5.6	USB .....	25
5.1.6	Encoder .....	26
5.1.7	Encoder emulation .....	27
5.1.8	Reset button .....	28
5.2	Software .....	29
<b>6</b>	<b>Installation</b> .....	<b>30</b>
6.1	General requirements .....	30
6.2	Dimensions .....	30
6.3	Installing the unit .....	31
6.4	Installing the fieldbus junction box .....	32

<b>7</b>	<b>Wiring</b>	<b>33</b>
7.1	Wiring guidelines	33
7.2	Supply voltage	33
7.3	Digital inputs	35
7.4	Digital outputs	37
7.5	Interfaces	39
7.5.1	CANopen X42	39
7.5.2	Ethernet X43	39
7.5.3	EtherCAT X44	40
7.5.4	CANopen, PROFIBUS X51	40
7.5.4.1	Wiring guidelines for the CANopen interfaces	41
7.5.5	CANopen X52	42
7.6	Encoder	43
7.6.1	Supply voltage	43
7.6.2	Incremental encoder with TTL signal	45
7.6.3	Absolute encoder with SSI interface	46
<b>8</b>	<b>Commissioning</b>	<b>48</b>
8.1	Safety guidelines	48
8.2	Commissioning the PMCprimo MC	49
8.2.1	Preparing for commissioning	49
8.2.2	Establish communication between PMCprimo MC and PC	51
8.2.3	Adapt basic configuration	54
8.2.4	Configure servo amplifier	55
8.2.5	Operate PMCprimo MC HW1 - Show Hardware	56
8.2.6	Operate PMCprimo MC HW2 - Show hardware	58
8.3	Install CODESYS	58
<b>9</b>	<b>Operation</b>	<b>59</b>
9.1	Operating states and changes in operating status	59
9.1.1	Status graph	59
9.1.2	Operating states	60
9.1.2.1	"Power Off" operating status	60
9.1.2.2	"Startup" operating status	60
9.1.2.3	"Boot Menu" operating status	60
9.1.2.4	"RUN" operating status	60
9.1.2.5	"STOP" operating status	61
9.1.2.6	"Fatal Error" operating status	61
9.1.3	Change in operating status	61
9.2	Reset, restart, start and stop options	63
9.2.1	Overview	63
9.2.2	Cold start, "Startup"	64
9.2.3	Reset commands	64
9.2.3.1	Warm reset	64
9.2.3.2	Cold reset	64
9.2.3.3	Original reset	65
9.3	Functions of the reset button	65
9.4	Messages	66

9.5	Display elements .....	67
<b>10</b>	<b>Technical details .....</b>	<b>69</b>
<b>11</b>	<b>EC declaration of conformity .....</b>	<b>73</b>
<b>12</b>	<b>UKCA-Declaration of Conformity .....</b>	<b>74</b>
<b>13</b>	<b>Order reference .....</b>	<b>75</b>
13.1	Product .....	75
13.2	Accessories .....	75

# 1 Introduction

## 1.1 Validity of documentation

This operating manual explains the function and operation, describes the installation and provides guidelines on how to connect the product.

This documentation is valid for the product PMCprimo MC. It is valid until new documentation is published.

Please also refer to the following documents from the motion control range:

- ▶ The online help for the PASmotion commissioning software describes how to set the parameters for the servo amplifiers from the PMC product area.
- ▶ Guidelines regarding installation and environmental conditions can be found in the operating manual for the servo amplifier PMCprotego D.
- ▶ The configuration and programming software for motion control devices (e.g. CODESYS, PASmotion) can be found on the Internet at [www.pilz.com](http://www.pilz.com).

You will need to be conversant with the information in these documents in order to fully understand this operating manual.

## 1.2 Retaining the documentation

This documentation is intended for instruction and should be retained for future reference.

## 1.3 Definition of symbols

Information that is particularly important is identified as follows:



### **DANGER!**

This warning must be heeded! It warns of a hazardous situation that poses an immediate threat of serious injury and death and indicates preventive measures that can be taken.



### **WARNING!**

This warning must be heeded! It warns of a hazardous situation that could lead to serious injury and death and indicates preventive measures that can be taken.



### **CAUTION!**

This refers to a hazard that can lead to a less serious or minor injury plus material damage, and also provides information on preventive measures that can be taken.



**NOTICE**

This describes a situation in which the product or devices could be damaged and also provides information on preventive measures that can be taken. It also highlights areas within the text that are of particular importance.



**INFORMATION**

This gives advice on applications and provides information on special features.

## 2 Overview

### 2.1 Unit features

PMCprimo MC is a motion controller used to automate multi-axis motion sequences. The device contains a PLC with the functionality of a logic and motion controller.

- ▶ Logic controller universally programmable in accordance with IEC 61131-3
- ▶ Motion control
  - Speed axes
  - Positioning axes
  - Synchronisation axes (electrical cam disk)
  - Path axes (interpolation)
  - Technology functions
- ▶ Digital inputs and outputs
  - 16 digital inputs, 6 of which are inputs, which can be used as reference inputs
  - 16 single-pole digital outputs
- ▶ 2/3 Mini-I/O sockets for encoder or 1 Mini-I/O socket (X41) for encoder emulation
  - Incremental encoder with TTL signal
  - Absolute encoder with SSI interface
- ▶ Supply voltages for
  - Device plus digital outputs
  - Encoder
- ▶ Memory for
  - Applications
  - Non-volatile data (non-volatile ST memory)
- ▶ USB interface for data exchange
- ▶ Reset button
  - For switching between operating states
  - For a hardware reset (cold start)
  - For importing project data when devices are exchanged
- ▶ LED display for device's operating status
- ▶ Interfaces
  - 1 Ethernet TCP/IP on RJ45 socket
  - 1 EtherCAT on RJ45 socket (from Hardware Version 04, see [Type label](#) [ 11])
  - 2 CANopen on RJ45 socket
  - 1 CANopen on 9-pin female D-Sub connector
- ▶ 1 CANopen or 1 PROFIBUS DP interface on 9-pin male D-Sub connector, selectable with software

## 2.2 Front view

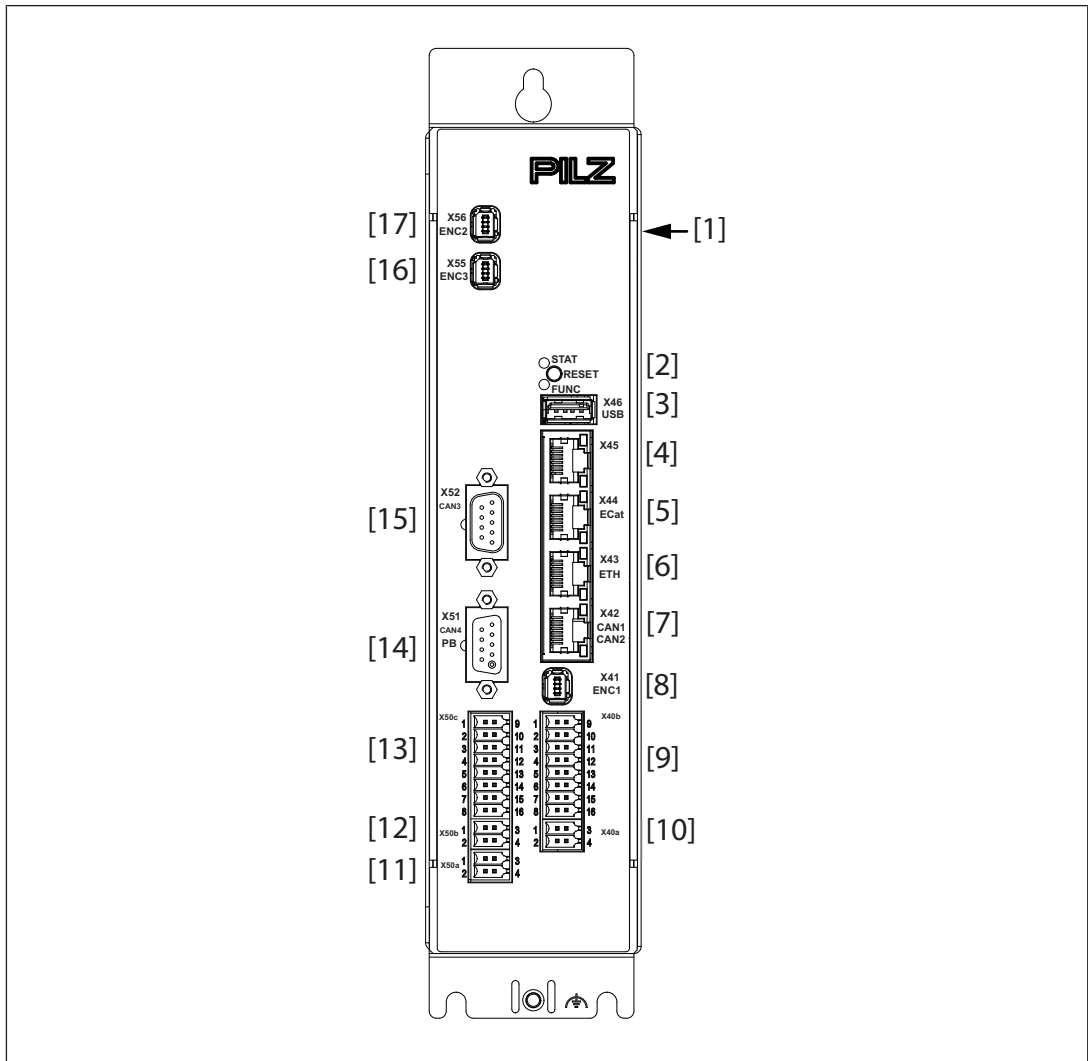

### Legend

- [1] Type label, on the side of the housing
- [2] Reset button and LEDs to display operating states
- [3] X46, USB interface
- [4] X45, unused
- [5] X44, EtherCAT interface (from Hardware Version 04, see [Type label \[11\]](#))
- [6] X43, Ethernet TCP/IP interface
- [7] X42, CANopen interfaces
- [8] X41, Connection for encoder 1 or in emulation mode: Output encoder
- [9] X40b, Digital inputs and outputs
- [10] X40a, supply voltages for device and encoder on the right-hand side of the device
- [11], [12] X50a, X50b, Supply voltages for device and encoder on the left-hand side of the device
- [13] X50c, Digital inputs/outputs
- [14] X51, CANopen/PROFIBUS DP interface

- [15] X52, CANopen interface
- [16] X55, Connection for encoder 2
- [17] X56, Connection for encoder 3

## 2.3 Type code

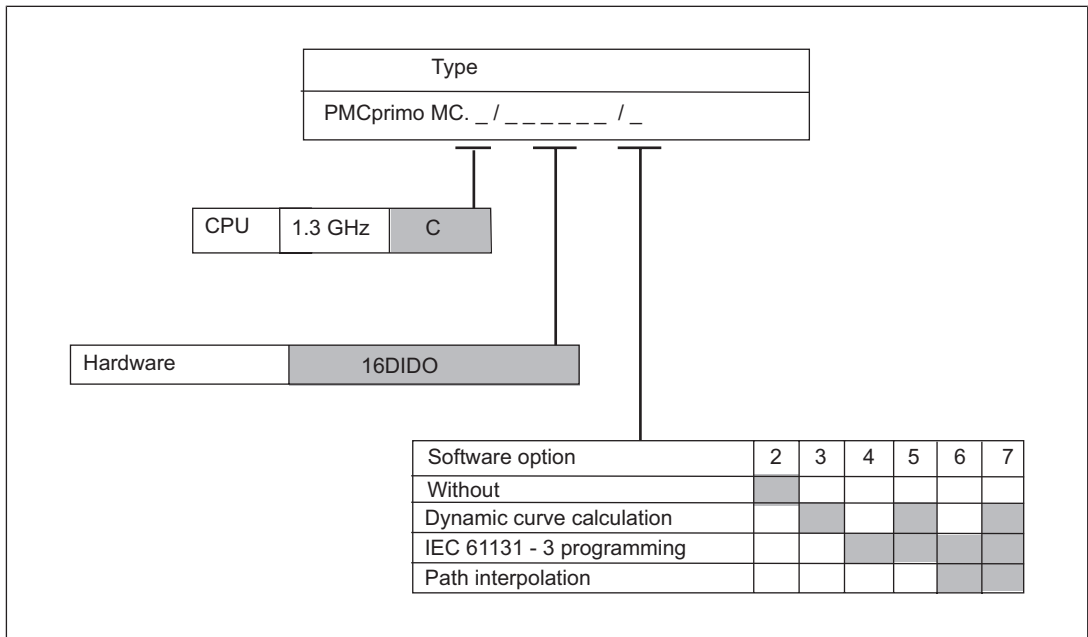

Fig.: PMCprimo MC type code

### Explanation of type code

► **CPU**

Clock frequency of processor

► **Hardware**

- Diverse interfaces, see section entitled [Interfaces \[22\]](#) plus an optional PROFIBUS DP Slave interface via software switching.

► **Software**

- **2:** Software options not enabled
- **3, 5, 7:** Dynamic curve calculation enabled  
The dynamic curve calculation is a calculation program for allocation tables.
- **4-7:** IEC 61231-3 programming enabled  
The PLC functionality is programmed with CODESYS.
- **6, 7:** Path interpolation enabled  
PLC functionality and path interpolation

## 2.4 Type label

The type label is positioned on the side of the motion controller.

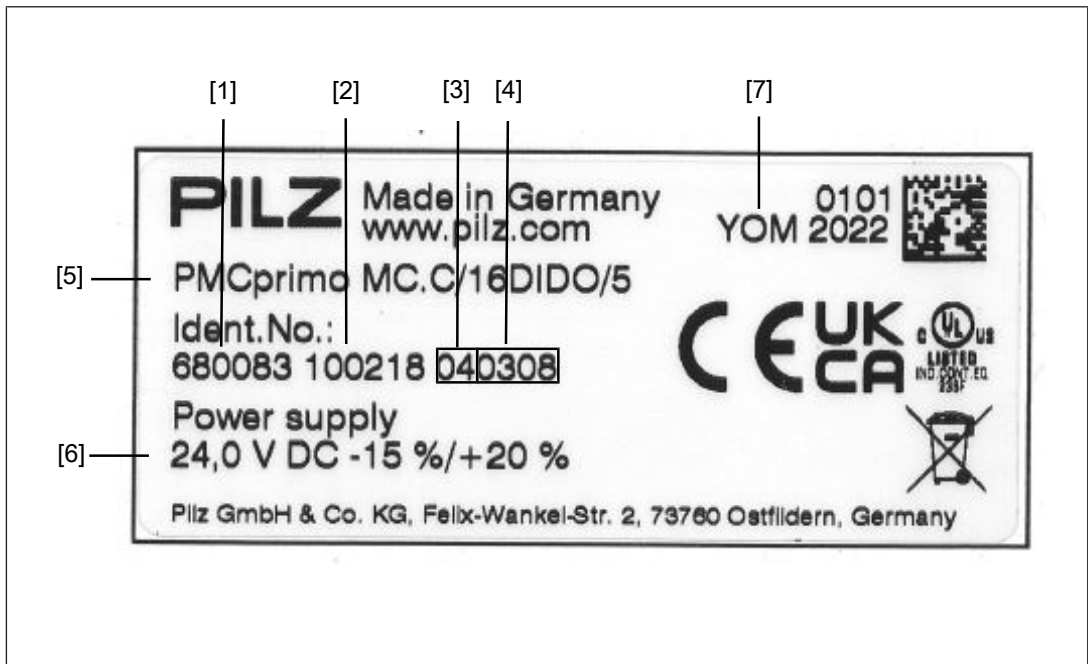

Fig.: Type label PMcprimo MC

### Legend

- [1] Order number
- [2] Serial number
- [3] Hardware version
- [4] Firmware version
- [5] [Type code](#)
- [6] Supply voltage, voltage tolerance
- [7] Year of manufacture

## 2.5 Scope

Order reference	Description	Order number
PMcprimo MC	Motion controller (for function range see "Type code")	See "Type code"

## 3 Safety

### 3.1 Intended use

The motion controller is suitable for use in logic and motion control applications.

Examples of typical application areas for the product are

- ▶ Clocked production machinery
- ▶ Continuous manufacturing processes (winding, flying saw, cross cutter)
- ▶ Machine tools
- ▶ Packaging machines
- ▶ Pick and place applications

#### Improper use

The following is deemed improper use in particular

- ▶ Any component, technical or electrical modification to the product,
- ▶ Use of the product outside the areas described in this operating manual,
- ▶ Use of the product outside the technical details (see Technical details).



#### NOTICE

##### EMC-compliant electrical installation

The product is designed for use in an industrial environment. The product may cause interference if installed in other environments. If installed in other environments, measures should be taken to comply with the applicable standards and directives for the respective installation site with regard to interference.

### 3.2 Safety regulations

#### 3.2.1 Use of qualified personnel

The products may only be assembled, installed, programmed, commissioned, operated, maintained and decommissioned by persons who are competent to do so.

A competent person is a qualified and knowledgeable person who, because of their training, experience and current professional activity, has the specialist knowledge required. To be able to inspect, assess and operate devices, systems and machines, the person has to be informed of the state of the art and the applicable national, European and international laws, directives and standards.

It is the company's responsibility only to employ personnel who

- ▶ Are familiar with the basic regulations concerning health and safety / accident prevention,
- ▶ Have read and understood the information provided in the section entitled Safety
- ▶ Have a good knowledge of the generic and specialist standards applicable to the specific application.

### 3.2.2 **Warranty and liability**

All claims to warranty and liability will be rendered invalid if

- ▶ The product was used contrary to the purpose for which it is intended,
- ▶ Damage can be attributed to not having followed the guidelines in the manual,
- ▶ Operating personnel are not suitably qualified,
- ▶ Any type of modification has been made (e.g. exchanging components on the PCB boards, soldering work etc.).

### 3.2.3 **Disposal**

- ▶ When decommissioning, please comply with local regulations regarding the disposal of electronic devices (e.g. Electrical and Electronic Equipment Act).

## 3.3 **Standards**

To use the device correctly you will need to have a good knowledge of the relevant standards and directives. The following standards are relevant:

- ▶ EN 61131-1: Programmable controllers – Part 1: General information
- ▶ EN 61131-2: Programmable controllers – Part 2: Equipment requirements and tests
- ▶ EN 61131-3: Programmable controllers – Part 3: Programming languages

Please note this is not an exhaustive list of safety standards and directives.

Where standards are undated, the 2015-05 latest editions shall apply.

## 4 Security

To secure plants, systems, machines and networks against cyberthreats it is necessary to implement (and continuously maintain) an overall industrial security concept that is state of the art.

Perform a risk assessment in accordance with VDI/VDE 2182 or IEC 62443-3-2 and plan the security measures with care. If necessary, seek advice from Pilz Customer Support.

### 4.1 Required security measures

- ▶ The product is not protected from physical manipulation or from reading of memory contents during physical access. Use appropriate measures to ensure that there is no physical access by unauthorised persons. You should also use security seals so that you can detect any manipulation of the product or interfaces. Installation inside a lockable control cabinet is recommended as a minimum measure.
- ▶ The configuration computer that accesses the product has to be protected from attacks by a firewall or other suitable measures. We recommend that a virus scanner is used on this configuration computer and updated regularly.
- ▶ If necessary, protect the configuration computer and the product from unauthorised use by assigning passwords and taking further measures if required. We also recommend that the user logged on to this configuration computer does not have administrator rights.
- ▶ Ensure that the product is separated by a router (layer 3 switch or firewall) from the company network.
- ▶ Assign only safe passwords. When assigning passwords, please note:
  - The password should have at least 8 characters.
  - The password should contain upper and lower case characters, as well as special characters and numbers.
  - If possible, the password should not be available in dictionaries.
  - The password should not be made up of standard variants and repetitions or keyboard patterns (so not: 1234abcd).
  - Use a password manager for optimum management of complex passwords.
  - Language-independent characters are not available in every keyboard language.
  - Make sure you regularly change the passwords of the user accounts on the system and/or ask the users to change their passwords themselves.
  - Make the users aware of the responsible use of their access data.
- ▶ Modbus/TCP has no security mechanisms. Use a firewall to protect the product from unauthorised access.
- ▶ As soon as possible, install firmware updates that Pilz provides for the product.
- ▶ The product permits firmware downgrades. Before you downgrade, you should check what firmware version you install to prevent re-opening up safety gaps that are already known and that were closed by a firmware update.
- ▶ Check the log of the product for security-relevant entries on a regular basis.
- ▶ Log data may contain personal data. Only store exported logs on a storage medium that is adequately protected.

- ▶ Use only one USB memory from a secure source. A manipulated USB memory could compromise the system.
- ▶ Before disposal, the product must be safely decommissioned. To do this, all the data must be deleted from the device.
  - Set the configuration back to its default settings or delete the configuration.
  - Switch off the product.
  - If the product includes a removable data medium, remove it and format it at the computer. Do not carry out a quick formatting. Alternatively, you can use a program to securely delete data or destroy the memory mechanically.

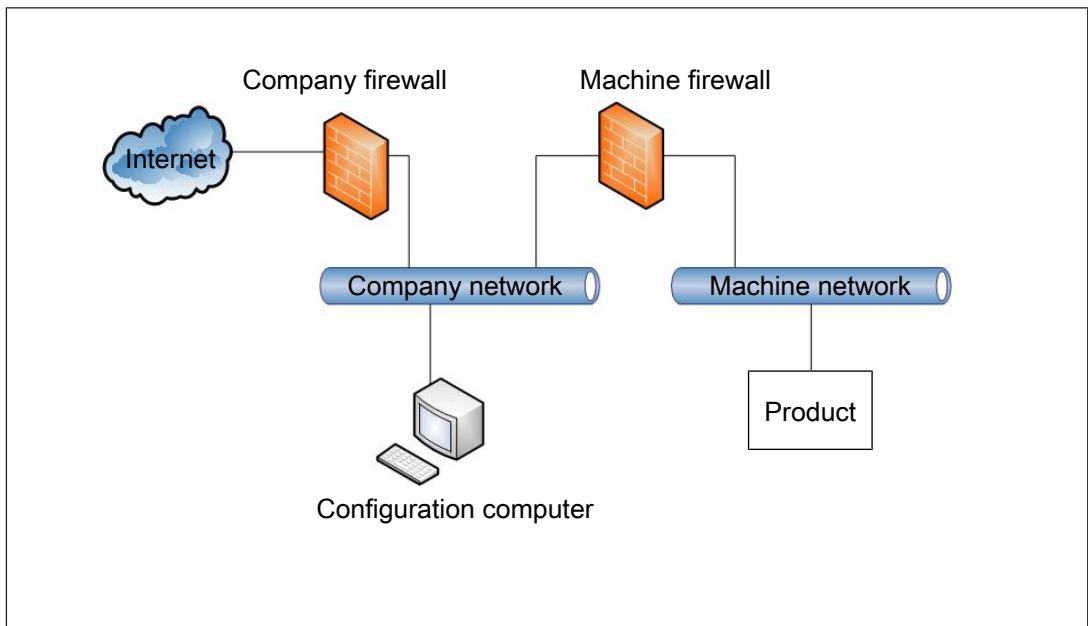

Fig.: Example network topology

- ▶ Protect the configuration and log data from unauthorised changes. Configure the display device so as to prevent unauthorised access to the file system.

## 5 Function description

### 5.1 Device properties

#### 5.1.1 Controller

The PMCprimo MC is a programmable logic controller with motion control functionalities. The controller has volatile and non-volatile memory for the operating system, the data and the device project with the user program.

It can be used for logic and motion control of intelligent drives.

User programs can be programmed in the main IEC 61131-3 languages. The software CODESYS is used to program the PLC functionality.

The motion controller has 16 digital inputs and 16 single-pole digital outputs. The inputs and outputs are read cyclically. The cycle time is  $\leq 1$  ms. It can also access inputs and outputs on networked servo amplifiers from the PMC product area.

The motion controller has fieldbus interfaces for communication with the periphery (EtherCAT: from Hardware Version 04 [Type label \[11\]](#)).

3 encoders can be connected (incremental encoder with TTL signal or absolute encoder with SSI interface).

Two LEDs provide information on the operating states of the controller and indicate any errors.

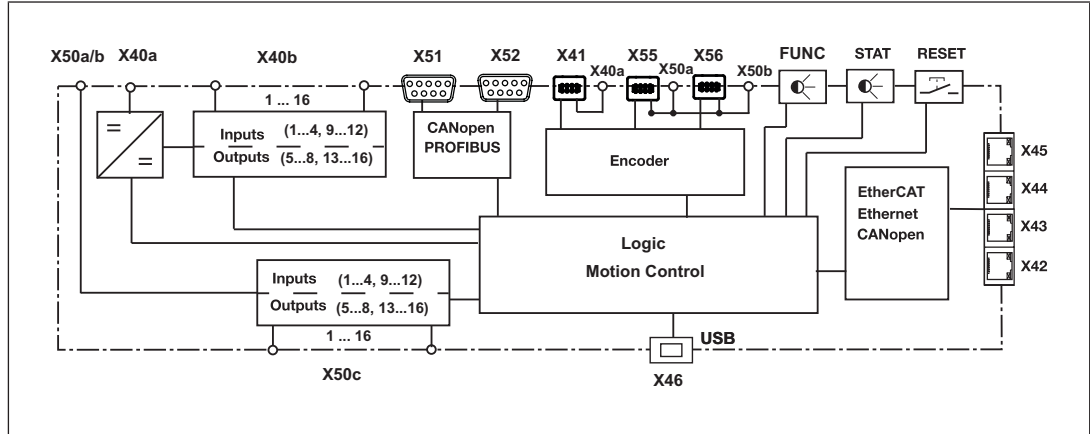

Fig.: Block diagram PMCprimo MC

### 5.1.1.1 Networking with servo amplifier

PMCprimo MC has the following options for networking with servo amplifiers:

#### Networking of PMCprimo MC (1) with the servo amplifier PMCprotego D (3)

- ▶ Via the communication protocol CANopen
- ▶ Via the interface X52 (9-pin D-Sub).

To create a connection, a fieldbus distributor PMCprotego D.CAN-Adapter (2) is required with the servo amplifier PMCprotego D.

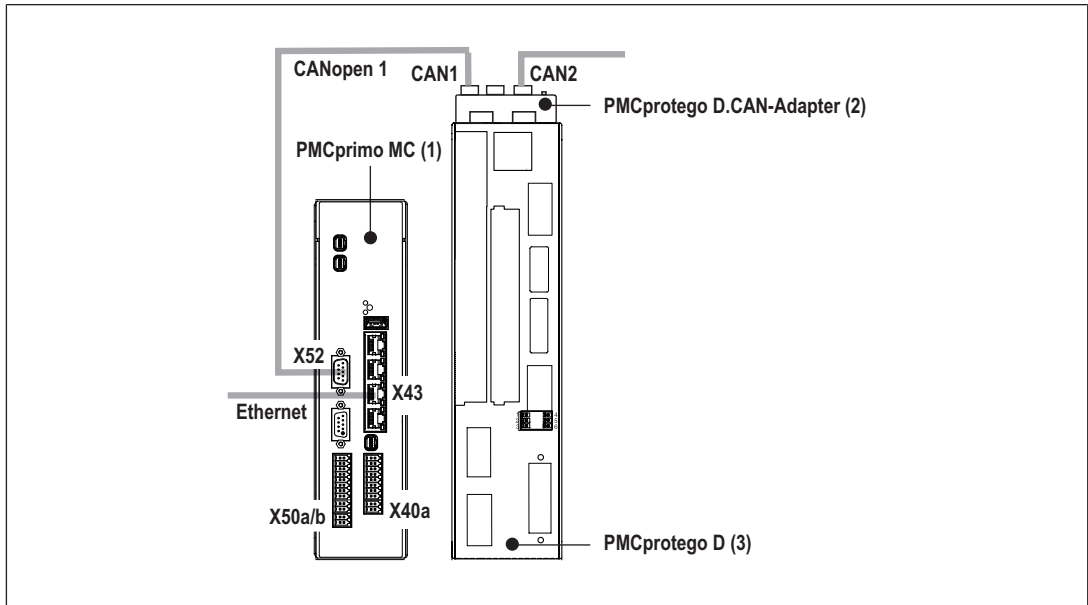

Fig.: Motion controller with servo amplifier, networking via CANopen

#### Networking of PMCprimo MC (1) with the servo amplifier PMCprotego D (3)

- ▶ Via the communication protocol CANopen
- ▶ Via the interface X42 (RJ45).

To create a connection, a fieldbus distributor PMCprimo DriveP.CAN-CAN-Adapter (2) is required with the servo amplifier PMCprotego D.

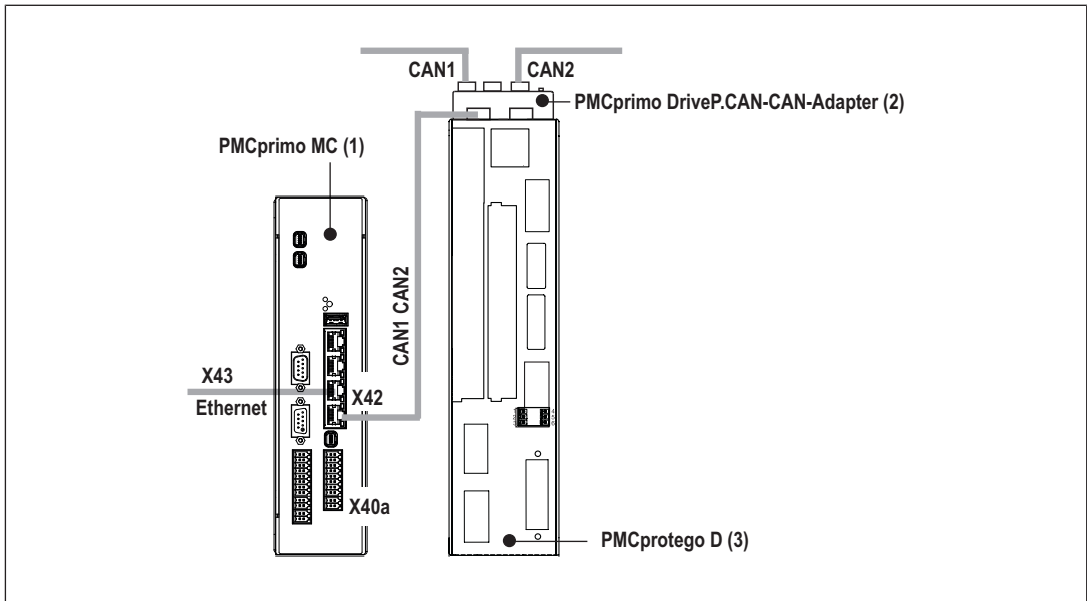

Fig.: Motion controller with servo amplifier, networking via CANopen

#### Networking of PMCprimo MC (1) with the servo amplifier PMCprotego D (3)

- ▶ Via the communication protocol EtherCAT (from Hardware Version 04, see [Type label \[ 11\]](#))
- ▶ Via the interface X44 (RJ45).

No adapter is required.

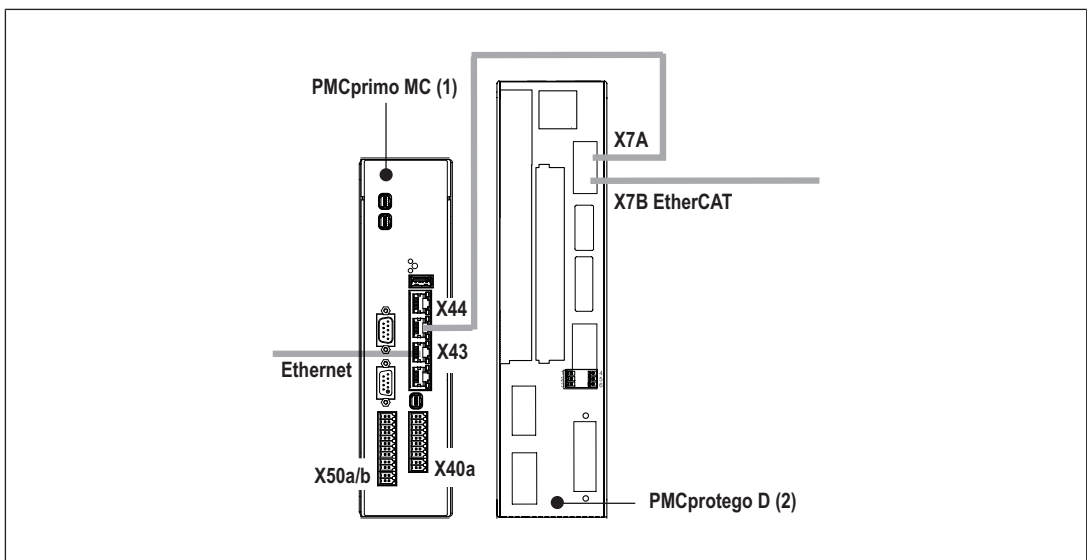

Fig.: Motion controller with servo amplifier, networking via EtherCAT



**INFORMATION**

Networking with PROFIBUS between servo amplifier and motion controller is not possible because both devices operate as slaves.

## 5.1.2 Connecting the supply voltage

Connect the following supply voltages to the device:

### Supply voltage for the device, the digital outputs and interfaces

▶ X40a/Pin 1 and Pin 3

Supply voltage for the device, the digital outputs X40b (24 VDC), the interfaces X42 to X45 and the interfaces X51 and X52

▶ X50a/Pin 1 and Pin 3 and X50b/Pin 1 and Pin 3

Supply voltage for the digital outputs X50c (24 V DC).

The following terminals are linked internally:

- X50a/Pin 1 and X50b/Pin 1 (24 V)
- X50a/Pin 3 and X50b/Pin 3 (0 V)
- X50a/Pin 2 and X50b/Pin 2
- X50a/Pin 4 and X50b/Pin 4

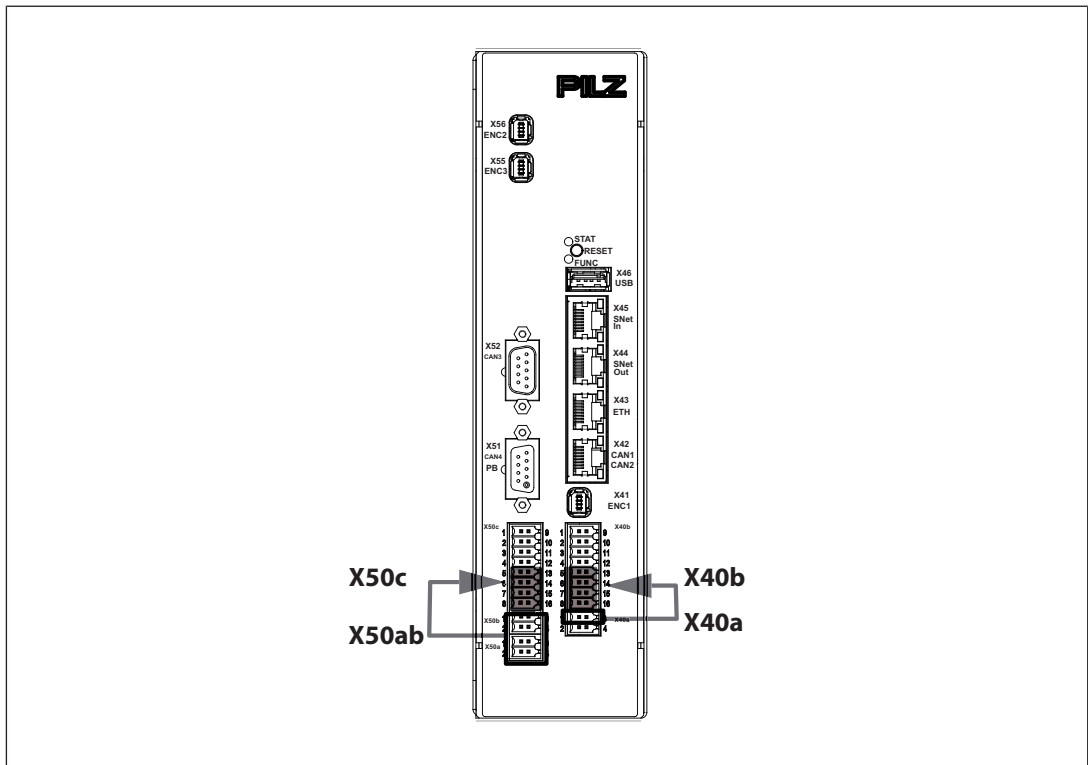

Fig.: Connecting the supply voltage for device, digital outputs and interfaces

### Connect the following supply voltages for the encoders:

▶ X40a/Pin 2 and Pin 4

Supply voltage for the encoder X41 (5 V, 10-30 VDC).

The voltage is wired directly to the Mini-I/O socket X41/Pin 1 and Pin 2.

▶ X50a/Pin 1 and Pin 3 and X50b/Pin 1 and Pin 3

Supply voltage for the two encoders X55 and X56 (5 V, 10-30 V DC).

The following terminals are linked internally:

- X50a/Pin 1 and X50b/Pin 1 (24 V)
- X50a/Pin 3 and X50b/Pin 3 (0 V)

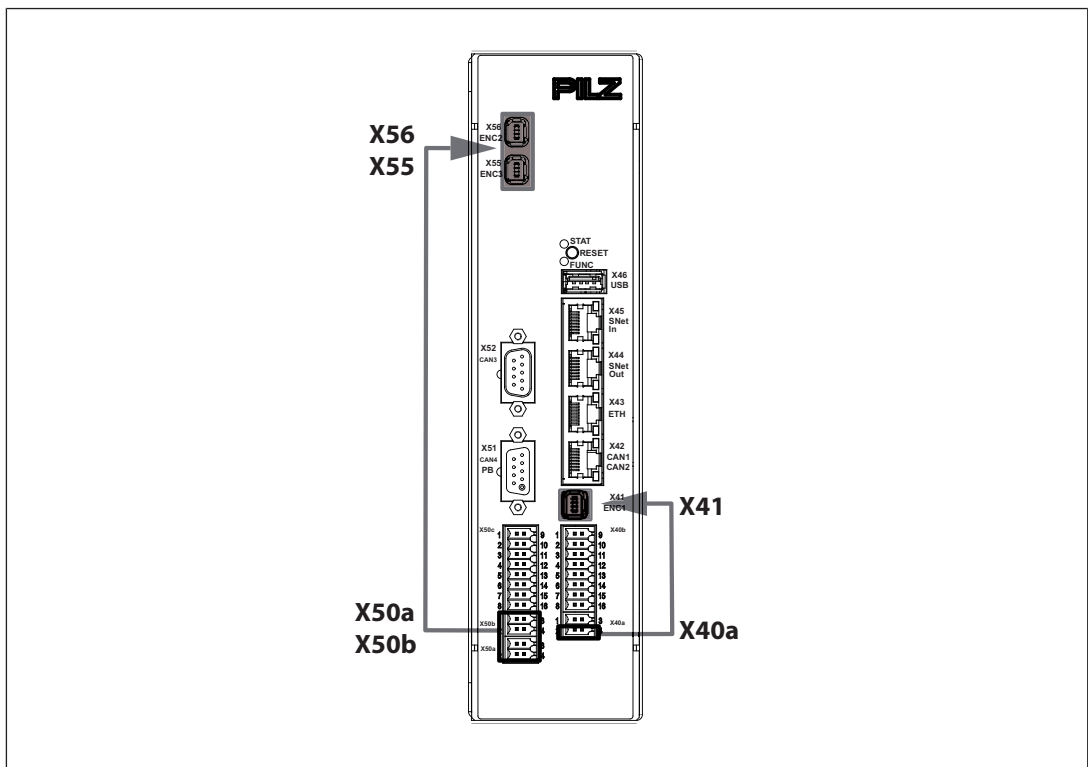

Fig.: Connecting the supply voltage for encoder



**CAUTION!**

**Risk of material damage by applying the supply voltage**

Do not connect the supply voltage for the encoder when the encoder input is used in emulation mode (as an output).

Further information on the emulation mode is available at: [Encoder emulation](#) [27].

### 5.1.3 Digital inputs

The device has 16 digital inputs (X40b: Pin 1 ... 4 and Pin 9 ... 12, X50c: Pin 1 ... 4 and Pin 9 ... 12).

The inputs are compatible with EN 61131-2, Type 1.

The time behaviour of the digital inputs depends on the method of use:

- ▶ With normal use, the inputs have a filter time of  $\leq 600 \mu\text{s}$ .
- ▶ If the inputs are used as reference inputs, the reaction time to 0/1 or 1/0 pulse edges is  $< 5 \mu\text{s}$ .
- ▶ The inputs can be used as reference inputs, to poll the position of the encoder for example.

## 5.1.4 Digital outputs

The device has 16 single-pole digital outputs (X40b: Pin 5 ... 8 and Pin 13 ... 16, X50c: Pin 5 ... 8 and Pin 13 ... 16).

Signals at the output

- ▶ "0" signal (0 V) at the output:
  - Output is high impedance
  - No current to the load
- ▶ "1" signal (+24 V) at the output:
  - Output is low impedance
  - Current is supplied to the load
  - The maximum current strength per output is 0.5 A.

All digital outputs are protected against short circuit and overload.

The outputs can be used to connect relays, valves or inputs from another controller, for example.

## 5.1.5 Interfaces

### 5.1.5.1 Overview

The motion controller PMCprimo MC has various fieldbuses for communication with the periphery. These are available on RJ45 sockets on the front of the device or 9-pin D-Sub connections. The interfaces are suitable for the following applications:

#### ▶ CANopen

- Real-time capable networking between CAN devices and the motion controller
- Suitable for applications
  - with  $\leq 49$  subscribers
  - with cycle time of  $\geq 1$  ms
  - in existing networks (e.g. with PM Ctendo DD5).
- Connection to the servo amplifier PMCprotego D via the fieldbus junction box PMCprotego D.CAN-CANbus Adapter (fieldbus junction box, can be ordered as an option)

#### ▶ PROFIBUS DP Slave

- Hardware switching via software command, from CANopen to PROFIBUS DP.
- Networking between the motion controller and a PROFIBUS Master.
- Suitable for data exchange with a third party controller.

#### ▶ Ethernet

##### – Ethernet TCP/IP

- Communication between the programming device and the motion controller
- Suitable for configuration, programming, commissioning

##### – Modbus TCP/IP

- Communications protocol based on Industrial Ethernet (TCP/IP over Ethernet).

- Suitable for networking between the motion controller and a visualisation device or a PSS 4000, for example.

▶ **EtherCAT as drive bus**

**The EtherCAT interface is available from Hardware Version 04, see [Type label](#) [ 11].**

- EtherCAT is an Ethernet-based master bus system suitable for industrial use. It is suitable for real-time capable networking between the motion controller PMCprimo MC and the servo amplifier PMCprotego D.
- The PMCprimo MC acts as Master
- Suitable for applications
  - with  $\leq 32$  subscribers
  - with cycle time of 1 ms

▶ **USB**

- For data exchange, see section entitled [USB](#) [ 25]

### 5.1.5.2

#### **CANopen**

The CAN network is designed as a linear structure. The CANopen communication protocol is based on CAN.

- ▶ CAN networking with the motion controller is suitable for applications with a maximum subscriber number of  $\leq 49$  and a cycle time  $\geq 1$  ms.
- ▶ Only CAN devices that are known to the controller or support a corresponding device profile can be operated in the motion controller's CAN network.
- ▶ CAN devices detected by the motion controller are ready for operation immediately after the initial network run-up. No complex configuration of the CAN devices is required.
- ▶ The overall line length and the length of the stub lines depend on the transmission rate, see section entitled [Wiring guidelines for the CANopen interfaces](#) [ 41].
- ▶ Process data objects (PDO) are defined for each CAN device type and cannot be customised by the user.
- ▶ For servo amplifiers, the "FS" command can be used to set which process data is to be exchanged between the motion controller and the servo amplifier (see "PMCprimo Programming Manual").
- ▶ The signal lines must be terminated with resistors (120 Ohm) on the first and last subscriber.
  - **Interface X42 (RJ45)**  
For a PMCprimo MC, a terminating resistor can be activated in the fieldbus junction box PMCprotego D.CAN-CANbus Adapter or PMCprotego D.CAN-PROFIBUS Adapter. The resistors are generally integrated within the connected devices and must not be activated there.
  - **Interface X51, X52 (9-pin D-Sub connector)**  
A terminating resistor is permanently installed between Pin 2 and Pin 7. The resistors are generally integrated within the connected devices and must not be activated there.

### 5.1.5.3 PROFIBUS DP

PROFIBUS is an open fieldbus standard. Communication is defined in IEC 61158 and IEC 61784. Further provisions have been defined in specifications published by the PROFIBUS User Group. These specifications are available from PROFIBUS International.

On a certain unit type, the PROFIBUS DP interface is available together with a CANopen interface on a 9-pin female D-Sub connector (X51).

Properties:

- ▶ The PROFIBUS is configured using the CD command: Slave address, address range, see "PMCprimo Programming Manual".
- ▶ PROFIBUS DP with CODESYS
  - Ignores configuration with CD command
  - 1000 16 Bit signed variables available they start from address 1000
- ▶ A total of up to 108 bus variables can be read and written in command language (see "PMCprimo Programming Manual"):
  - Address space of bus variables: \$B1 to \$Bx108 (can be set using the CD command).
  - Data width: 16 Bit including sign
  - Value range: -32768 to 32767 (Hex: 0x0000 bis 0x7FFF).



#### INFORMATION

The GSD file is available on the Pilz homepage. The name of the description file can be found in [Technical details](#) [ 69].



#### INFORMATION

Please also refer to the installation guidelines published by the PROFIBUS User Group.

### 5.1.5.4 Ethernet

The Gigabit Ethernet interface (X43) connects the PMCprimo MC to a programming device for configuration, programming and commissioning. The interface can also be used to connect a visualisation device.

The Gigabit Ethernet interface is compatible with 1000Base-T (Standard Gigabit Ethernet). Data exchange is possible via Modbus/TCP.

### 5.1.5.5 EtherCAT

The EtherCAT interface is available from Hardware Version 04, see [Type label](#) [ 11].

EtherCAT uses the Ethernet Standard (IEEE 802.3) without modifications.

The PMCprimo MC does not require a setting (CD command) to use the EtherCAT master as a drive bus.

To do this, however, a CODESYS V3 project must be active (Boot project), where all the EtherCAT devices are configured.

Before the CODESYS project starts, all the devices must be operational so that they are detected by the EtherCAT master.

The address assignment of the network subscribers is performed automatically in the sequence of the physical arrangement. The sequence of the inserted devices in the device tree must match the physical arrangement.

Please note the following during operation:

- ▶ The device sequence may no longer be modified.
- ▶ It is not permitted to add or remove devices.

The PMCprimo MC is an EtherCAT master, which is the only subscriber in the segment that can actively send an EtherCAT frame; all the other subscribers only forward the frames. This prevents unforeseeable delays and it guarantees real-time capability.

Bit errors in the transmission are reliably detected in the evaluation of CRC check sums. Rare interferences can be detected and localised with EtherCAT even if the interference does not influence the functionality of the machine.

#### 5.1.5.6

#### USB



#### INFORMATION

Use a USB stick with FAT32 formatting.

- ▶ The USB port is used to transfer data for a device exchange.
- ▶ The data can contain a new firmware with a complete project.
- ▶ **Save data from a controller to a USB stick:**
  - The data is saved on a USB stick in the following directory: "\\PILZ\primoBACKUP\"

**The following options are available for saving data from the PMCprimo on a USB stick:**

- ▶ Save via the command SP11
- ▶ Save via the reset button

#### Save via the command SP11

To enter the command SP11, the PMCprimo must be connected to the terminal program on PASmotion.

#### Save via the reset button

- ▶ Make sure that the "\\PILZ\" directory does not exist on the USB stick (avoid overwriting unintentionally).

- ▶ Insert USB stick
- ▶ Press the reset button during the boot process until the LEDs flash blue.  
The LEDs remain off during the save process and this may take a few minutes.  
When the LEDs are a constant blue, the save process is complete and the PMCprimo can be switched off again.

**The following options are available for reading data from the USB stick to the PMCprimo:**

- ▶ Read via the command RD11
- ▶ Read via the reset button

#### **Read via the command RD11**

To enter the command RD11, the PMCprimo must be connected to the terminal program on PASmotion.

#### **Read via the reset button**

- ▶ Insert USB stick
- ▶ In the ON state, press the reset button until the LEDs flash blue.  
The device will restart automatically once the data has been read in.

Further information on the reset button is available under [Functions of the reset button](#)  65].

## **5.1.6**

### **Encoder**

Depending on the configuration, the device has

- ▶ 3 encoder connections X41, X55 and X56 (Mini I/O sockets)
- ▶ 2 encoder connections X55 and X56 (Mini I/O sockets) and 1 encoder connection X41 for [Encoder emulation](#)  27]

The following encoders are supported:

- ▶ Incremental encoder with TTL signal
- ▶ Absolute encoder with SSI interface

The supply voltages of the encoders are connected to separate terminals of the device

- ▶ X40a/Pin 2 and Pin 4 for encoder at X41
- ▶ X50a/X50b/Pin 2 and Pin 4 combined for encoders at X55 and X56

The size of the voltage depends on the encoder (e.g. 5 V, 10 - 30 VDC).



#### **INFORMATION**

For details of how to connect the supply voltage see [Supply voltage](#)  33].

### Encoder emulation

The encoder connection X41 can be used as an output, see [Encoder emulation \[27\]](#).



#### CAUTION!

##### Risk of material damage by applying the supply voltage

Do not connect the supply voltage for the encoder when the encoder input is used in emulation mode (as an output).

## 5.1.7

### Encoder emulation

Prerequisite: Motion Controller from Firmware version 0305 (see [Type label \[11\]](#))

To interconnect motion controllers and to be able to synchronise the position, the **encoder input X41** can be used as an output. The output emulates the behaviour of a relative incremental encoder and it works as a virtual axis.

For each increment, the virtual axis moves and the A/B signal changes. So the relative position of a motion controller (master) to another motion controller (slave) can be communicated.

Further information on the encoder emulation can be found in the chapter [Technical details. \[69\]](#)



#### CAUTION!

##### Risk of material damage by applying the supply voltage

Do not connect the supply voltage for the encoder when the encoder input is used in emulation mode (as an output).

**Software settings are required (see PMCprimo programming manual) to activate this function:**

- ▶ Using the software tool CODESYS: In the function block "SetFeedbackEncoder"
- ▶ Using the software tool PASmotion with command language: FS 37



#### NOTICE

The maximum output frequency of the encoder emulation is 250 kHz (250000 incr./s). When the output frequency is exceeded, no further signals are output at the output.



**INFORMATION**

Only one device must be operated at the output (X41) of the encoder emulation. To connect several devices to the encoder interfaces, you require a splitter that amplifies the signals.

**5.1.8**

**Reset button**

The "RESET" button is mounted in a recess on the front of the unit. It can only be accessed using an appropriate tool (e.g. a pin).

The following actions can be triggered by pressing the "RESET" pushbutton:

- ▶ Change from "Startup" operating status to "Boot Menu"
- ▶ Hardware reset (cold start): Change from operating states "RUN" or "STOP" to "Startup" (if a USB stick is inserted, any device data present will be copied, see [Functions of the reset button](#)  65.)
- ▶ Change from "RUN" operating status to "STOP"
- ▶ Change from "STOP" operating status to "RUN"



**INFORMATION**

For further information on the reset button see the chapter entitled [Operation](#)  59].

## 5.2 Software

Various tools are available for planning, configuration, programming and commissioning. They are used to create a project:

▶ PASMotion

PASMotion is used to parameterise and commission the motion controller and the servo amplifier PMCprotego D.

- Terminal program: The terminal can be used to transfer commands directly to the hardware. It can also be used for firmware updates and for basic configuration of the motion controller.
- Oscilloscope function: PScope is a PC-based oscilloscope with up to 4 channels. It can be used to record and visualise signals from controllers and servo amplifiers.
- Elliptical curve tool: PMotion is a tool for constructing elliptical curves.

▶ Development environment in accordance with IEC 61131-3

CODESYS is a development environment for programming controllers in accordance with IEC 61131-3. Additional commands for motion sequences have been added. In addition to the core CODESYS packages the "PMC Programming Tool" also contains the target support packages and the PMCprimo base project.

The software tools are available on the Internet at [www.pilz.com](http://www.pilz.com).

## 6 Installation

### 6.1 General requirements



**NOTICE**

**Damage due to electrostatic discharge!**

Electrostatic discharge can damage components. Ensure against discharge before touching the product, e.g. by touching an earthed, conductive surface or by wearing an earthed armband.

### 6.2 Dimensions

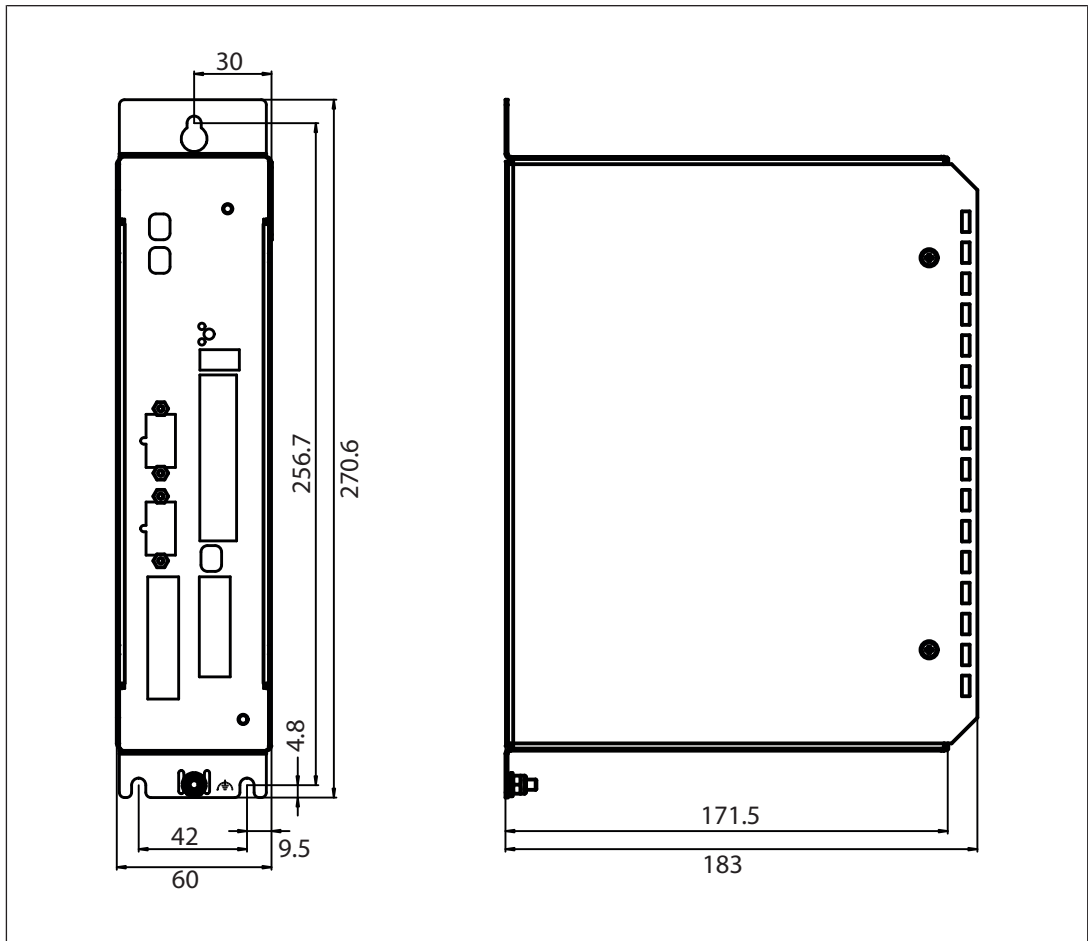

Fig.: Dimensions, stated in mm

### 6.3 Installing the unit

- ▶ Installation materials: 3 hexagon socket cylinder head screws DIN 912, M5
- ▶ Required tool: Hexagonal wrench 4 mm

Follow the instructions below:

- ▶ Drill M5 holes in the control cabinet's mounting plate, as shown in the illustrations.

Attach the device to the control cabinet's mounting plate with a minimum distance of >5 mm to the adjacent servo amplifier.

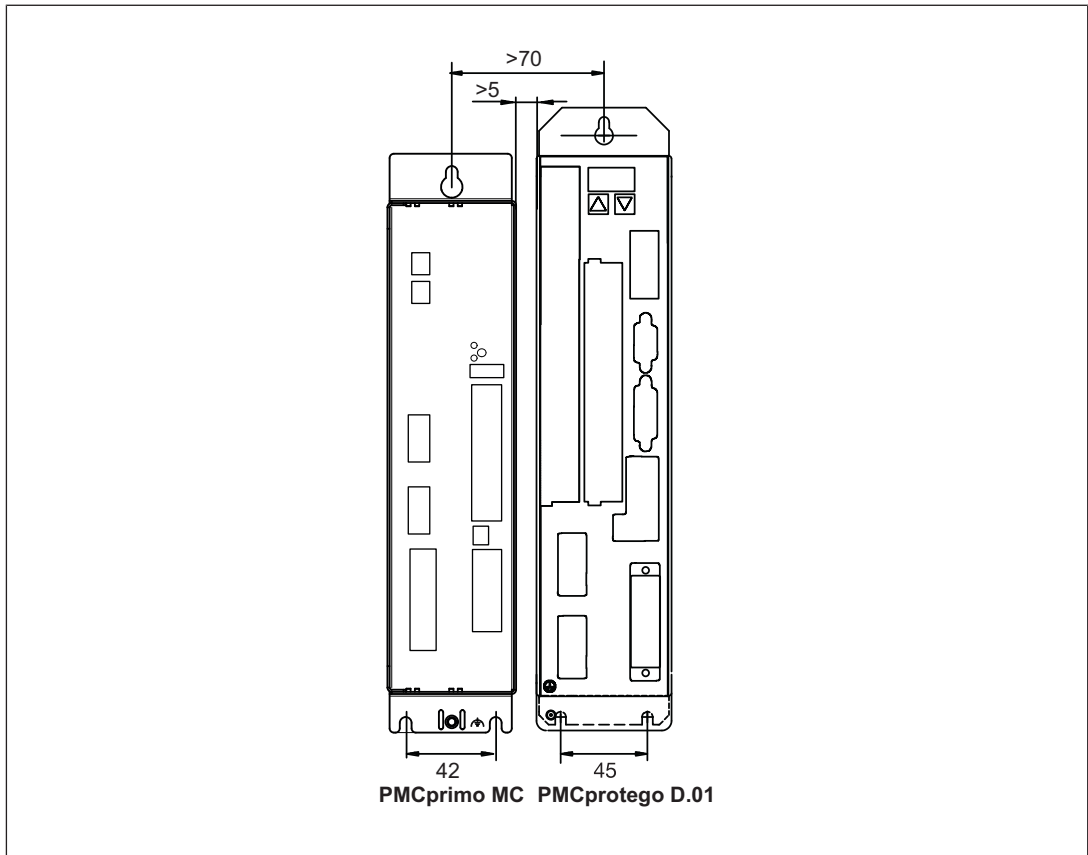

Fig.: Installing the motion control system next to a servo amplifier

## 6.4 Installing the fieldbus junction box

To network a PMCprimo MC via CANopen, PROFIBUS DP you need a fieldbus junction box. This is available as an accessory. The fieldbus junction box is plugged into the servo amplifier.



### INFORMATION

Pin assignment, wiring and assembly are described in the operating manual for the fieldbus junction box.

To install the fieldbus junction box, follow the instructions below:

- ▶ Switch off the mains voltages and 24 V supply.
- ▶ Connect the 9-pin female D-Sub connector X6D to the male connector X6 on the servo amplifier.
- ▶ Turn the screws into the thread on the housing.

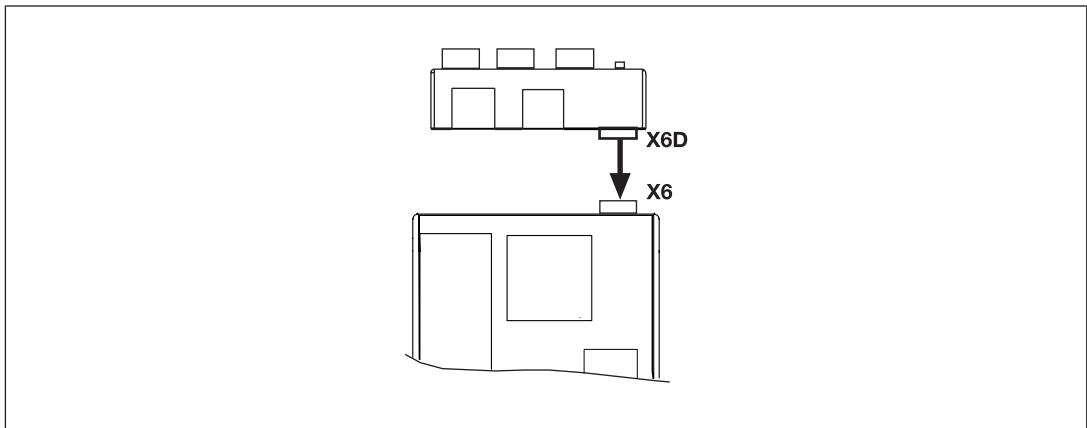

Fig.: Installing the fieldbus junction box on a servo amplifier

## 7 Wiring

### 7.1 Wiring guidelines

Please note:

- ▶ Cable cross sections for field connection terminals in mm<sup>2</sup>:
  - Digital inputs/outputs, supply voltage: 0.5 (AWG20) ... 1.0 (AWG18), crimp connectors with plastic collar
  - 0.75 mm<sup>2</sup> [H 0.75/16D] metrical. Ferrule length 12 mm, stripping length 14 mm
  - 0.5 mm<sup>2</sup> [H 0.5/16D] metrical. Ferrule length 10 mm, stripping length 12 mm

Inputs

- ▶ Appropriate wiring must be used to exclude short circuits between the inputs or to a supply line.
- ▶ Cables must be shielded if the signals are used as reference inputs. Other signal lines do not need to be shielded.

Outputs

- ▶ If short circuits occur between the cable from the output to the load and a supply line, it will no longer be possible to switch off the load.  
Possible remedy: Use separate multicore cable for supply voltages.
- ▶ Use appropriate wiring to exclude short circuits between the outputs.
- ▶ The actuators may be connected using unshielded cables.
- ▶ The outputs do not need suppression for inductive loads.

Cable material

- ▶ Use copper wiring.

### 7.2 Supply voltage

The digital outputs and the unit need a 24 VDC supply.

- ▶ When selecting the power supply, please refer to the requirements stated under “Technical Details”.
- ▶ The power supply must be able to bridge a power outage of 20 ms.





**WARNING!**  
**Electric shock!**

Safe electrical isolation must be ensured for the external power supply that generates the supply voltage. Failure to do so could result in electric shock. The power supplies must comply with EN 62368-1, EN 61558-2-6, 08:2009.

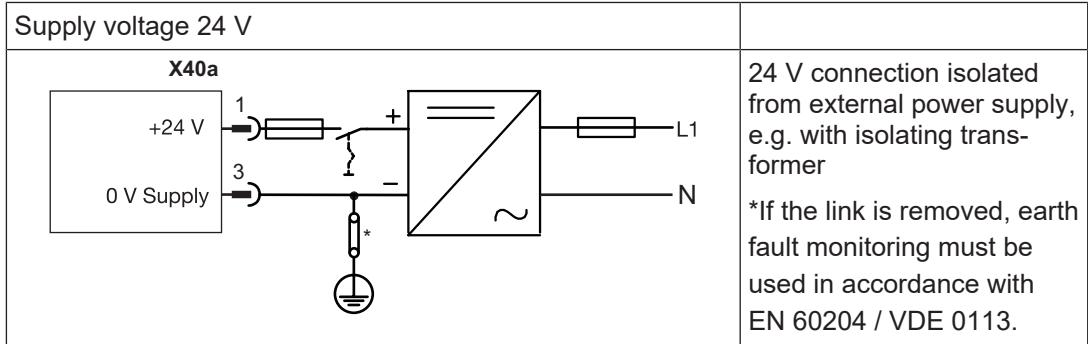
Connector X40a	Pin	Designation	Description
	1	+24 V	Supply voltage +24 VDC
	3	0 V supply	Earth for supply voltage
Supply voltage for: the device, digital outputs X40b, interfaces X42 to X45 and interfaces X51 and X52			

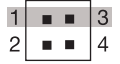

Connector X50a/ X50b	Pin	Designation	Description
 	1	+24 V	Supply voltage +24 VDC
	3	0 V supply	Reference earth for digital inputs X50c
Supply voltage for the two encoders X55 and X56 the digital outputs X50c			

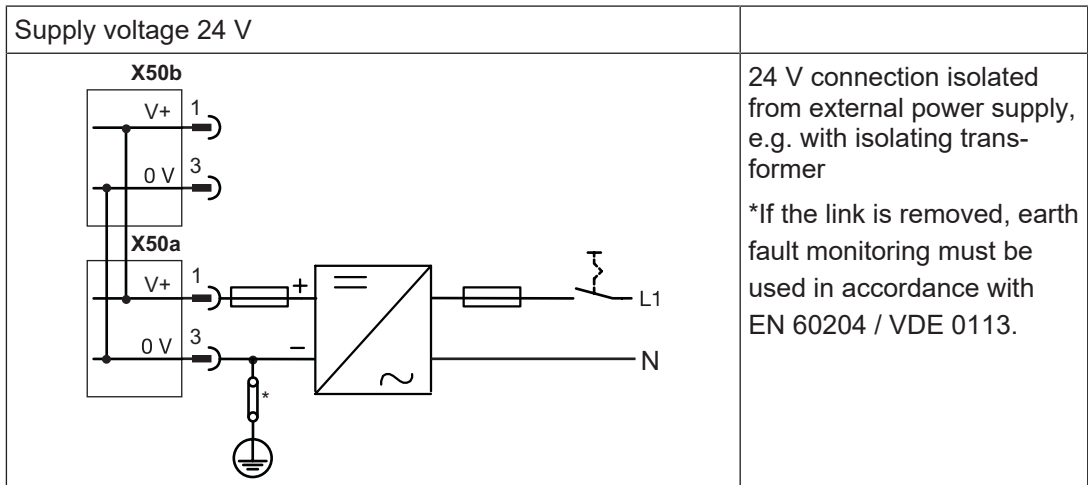

### 7.3 Digital inputs

Connector X40a, X40b	Pin	Designation	Description
	<b>X40b</b>		
	1	I1:1	Digital, fast input 1
	2	I1:2	Digital, fast input 2
	3	I1:3	Digital, fast input 3
	4	I1:4	Digital, fast input 4
	9	I1:5	Digital, fast input 5
	10	I1:6	Digital, fast input 6
	11	I1:7	Digital input 7
	12	I1:8	Digital input 8
	<b>X40a</b>		
	3	0 V	Reference earth for digital inputs

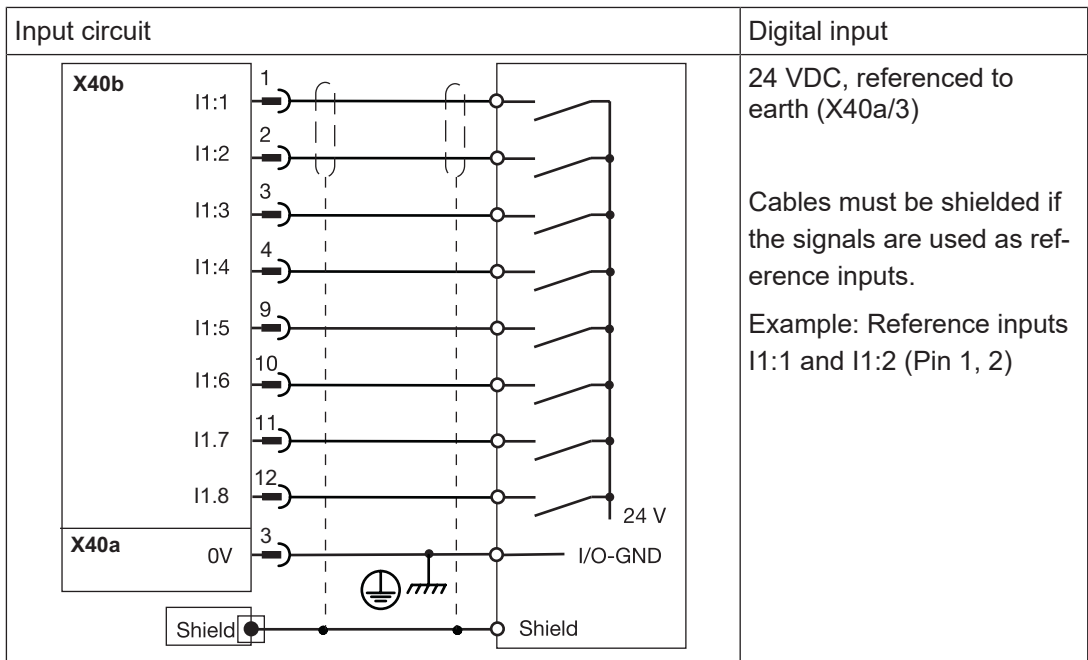

Connector X50a, X50b, X50c	Pin	Designation	Description
<b>X50c</b> 1 ■ ■ 9 2 ■ ■ 10 3 ■ ■ 11 4 ■ ■ 12 5 ■ ■ 13 6 ■ ■ 14 7 ■ ■ 15 8 ■ ■ 16  <b>X50b</b> 1 ■ ■ 3 2 ■ ■ 4  <b>X50a</b> 1 ■ ■ 3 2 ■ ■ 4	<b>X50c</b>		
	1	I2:1	Digital input 1
	2	I2:2	Digital input 2
	3	I2:3	Digital input 3
	4	I2:4	Digital input 4
	9	I2:5	Digital input 5
	10	I2:6	Digital input 6
	11	I2:7	Digital input 7
12	I2:8	Digital input 8	
	<b>X50b</b>		
	3	0 V	Reference earth for digital inputs
	<b>X50a</b>		
	3	0 V	Reference earth for digital inputs

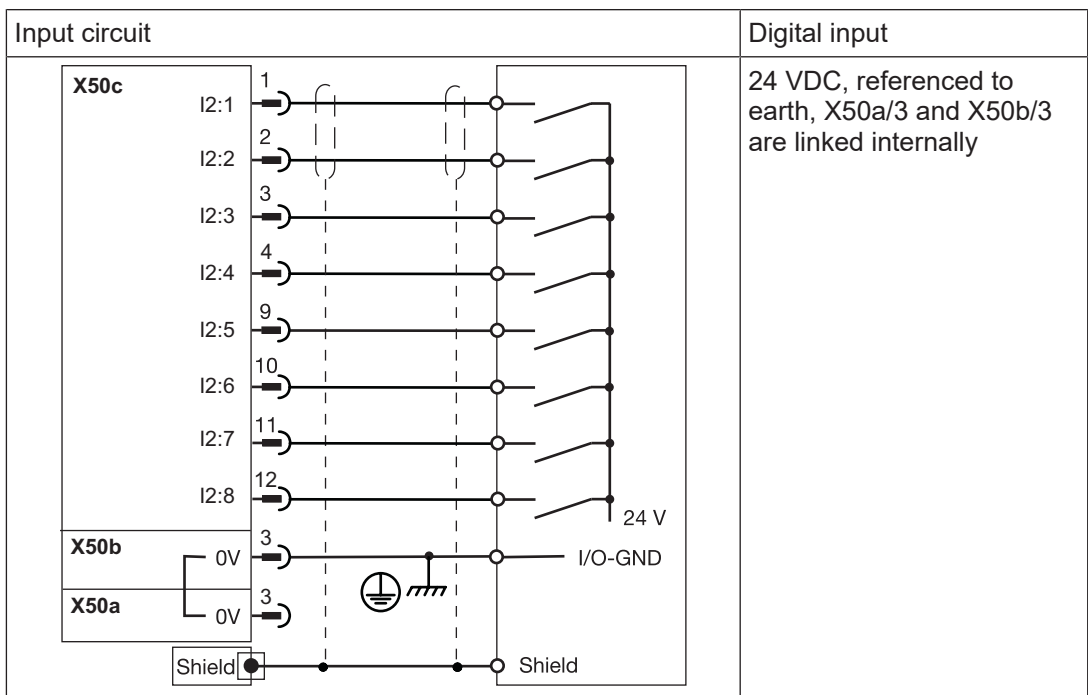

## 7.4 Digital outputs

Connector X40a, X40b	Pin	Designation	Description
	<b>X40b</b>		
	5	O1:1	Digital output 1
	6	O1:2	Digital output 2
	7	O1:3	Digital output 3
	8	O1:4	Digital output 4
	13	O1:5	Digital output 5
	14	O1:6	Digital output 6
	15	O1:7	Digital output 7
	16	O1:8	Digital output 8
	<b>X40a</b>		
	1	+24 V	Supply voltage for digital outputs
	3	0 V supply	Reference earth for digital outputs

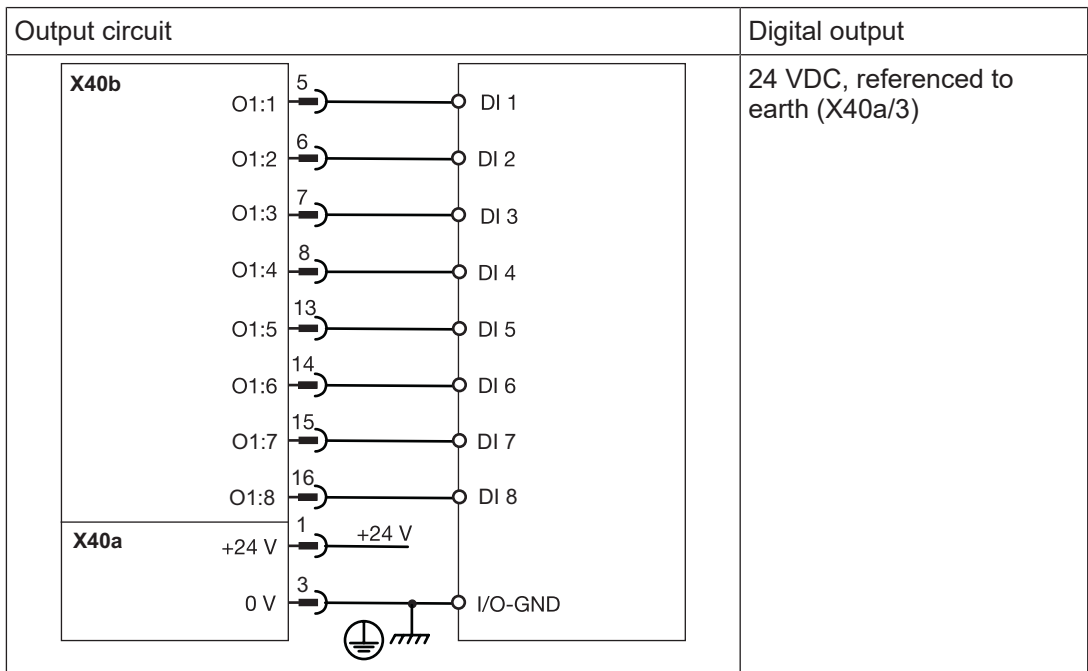

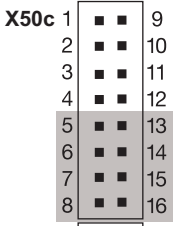
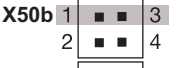
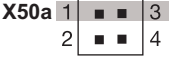
Connector X50a, X50b, X50c	Pin	Designation	Description	
 <p>X50c 1 9 2 10 3 11 4 12 5 13 6 14 7 15 8 16</p>	<b>X50c</b>			
	5	O2:1	Digital output 1	
	6	O2:2	Digital output 2	
	7	O2:3	Digital output 3	
	8	O2:4	Digital output 4	
	 <p>X50b 1 3 2 4</p>	13	O2:5	Digital output 5
		14	O2:6	Digital output 6
	 <p>X50a 1 3 2 4</p>	15	O2:7	Digital output 7
16		O2:8	Digital output 8	
	<b>X50a</b>			
	<b>X50b</b>			
	1	+24 V	Supply voltage for digital outputs	
	3	0 V supply	Reference earth for digital outputs	

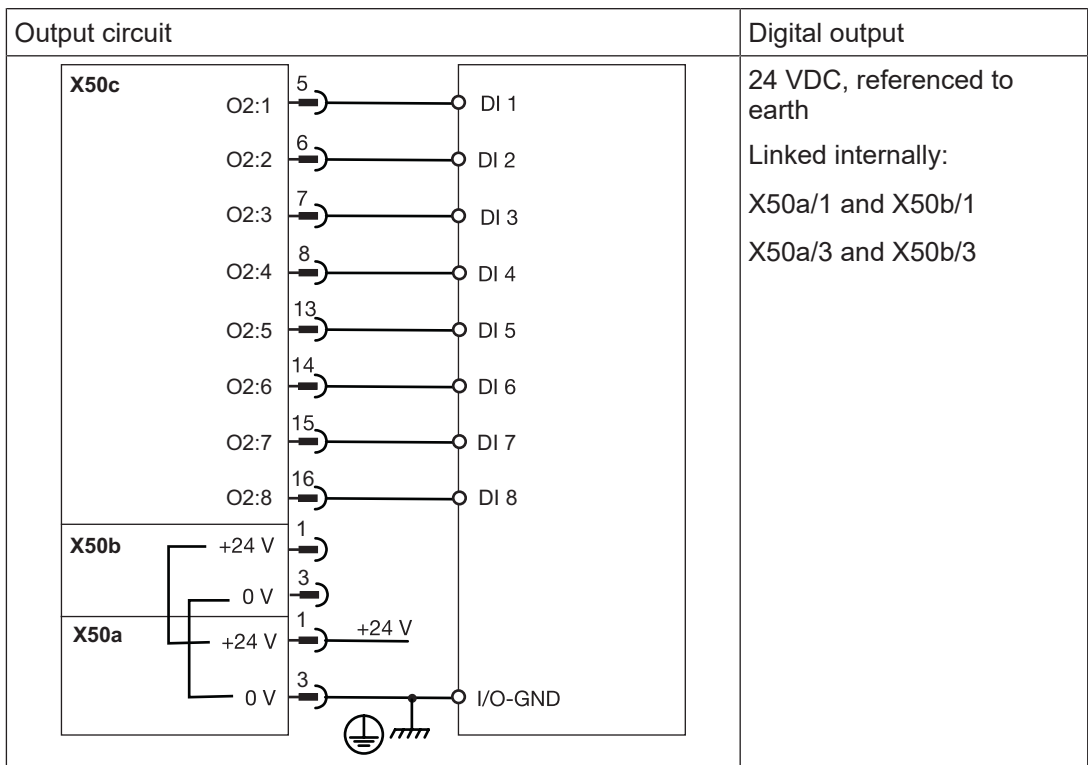

## 7.5 Interfaces

### 7.5.1 CANopen X42

There are two CANopen interfaces on the same socket. The two CANopen interfaces use the same operating earth (GND).

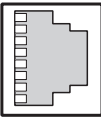
Socket X42	Pin	Designation	Description
	1	n. c.	
	2	n. c.	
	3	GND	Ground
	4	CAN2_H	CAN2 high signal
	5	CAN2_L	CAN2 low signal
	6	GND	Ground
	7	CAN_H	CAN1 high signal
	8	CAN_L	CAN1 low signal
n.c. = not connected			
Device type: 2 CANopen interfaces Connection via fieldbus junction box on the servo amplifier PMC-protego D			

### 7.5.2 Ethernet X43

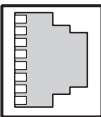
Socket X43	Pin	Designation	Description
	1	D1+	TX D1+
	2	D1-	TX D1-
	3	D2+	RX D2+
	4	D3+	BI D3+
	5	D3-	BI D3-
	6	D2-	RX D2-
	7	D4+	BI D4+
	8	D4-	BI D4-

The Ethernet interface is compatible with 1000Base-T (Standard Gigabit Ethernet)

Recommended cable: Cat5e SF/UTP

### 7.5.3 EtherCAT X44

The EtherCAT interface is available from Hardware Version 04, see [Type label](#) [11].

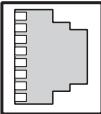
Socket X44	Pin	Designation	Description
	1	TD+	Transmit +
	2	TD-	Transmit -
	3	RD+	Receive +
	4	n. c.	
	5	n. c.	
	6	RD-	Receive -
	7	n. c.	
	8	n. c.	
n. c. = not connected			

Recommended cable: Cat5e SF/UTP

### 7.5.4 CANopen, PROFIBUS X51



**INFORMATION**

Use a straight design with axial cable routing as the PROFIBUS connector/ CANopen connector.

The PROFIBUS DP and CANopen interface are on the same socket. The PROFIBUS DP and CANopen interface use the same operating earth (GND). The PROFIBUS DP interface is implemented in accordance with the PROFIBUS-DP specification.

**CANopen interface**

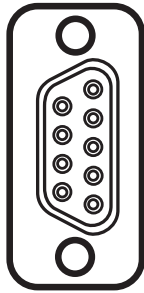
Socket X51	Pin	Designation	Description
	1	n. c.	n. c.
	2	CAN_L	CAN low signal
	3	GND	Ground
	4	n. c.	n. c.
	5	n. c.	n. c.
	6	n. c.	n. c.
	7	CAN_H	CAN high signal
	8	n. c.	n. c.
n. c. = not connected			

**PROFIBUS DP interface**

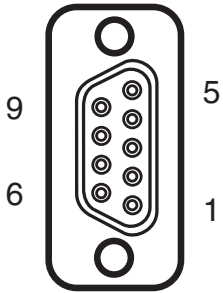
Socket X51	Pin	Designation	Description
	1	n. c.	n. c.
	2	n. c.	n. c.
	3	RxD/TxD-P	PROFIBUS B cable
	4	n. c.	n. c.
	5	GND	Ground
	6	+5 VDC / 50mA	Supply voltage for terminating resistors
	7	n. c.	n. c.
	8	RxD/TxD-N	PROFIBUS A cable
	n. c. = not connected		

**7.5.4.1**

**Wiring guidelines for the CANopen interfaces**

The CAN network is designed in a linear structure.

- ▶ The overall line length and the length of the stub lines depend on the transmission rate and on the cable properties (cable resistance and cable capacitance).
- ▶ The signal lines must be terminated with resistors on the first and last subscriber.
- ▶ A characteristic impedance of 120 Ohm is acceptable for bus lengths up to 40 m.
- ▶ A terminating resistor is permanently installed between Pin 2 and Pin 7.

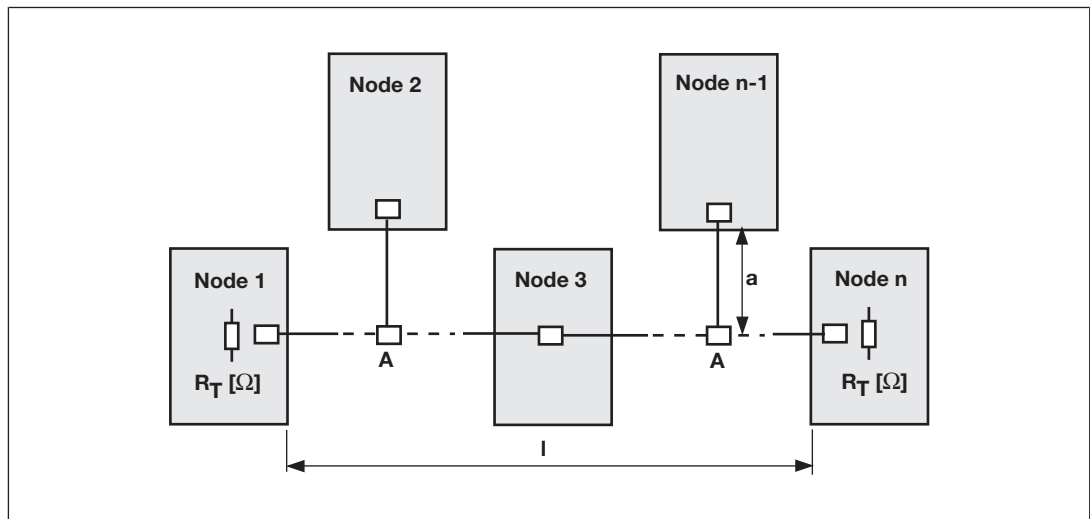

Fig.: Overall length and length of the stub lines on a CAN network.

Legend:

- ▶ Node: CANopen subscriber
- ▶ a: Length of stub line
- ▶ A: Branch
- ▶  $R_T$ : Terminating resistor

Relationship between transmission rate, bus length and length of stub lines:

Transmission rate [kBit/s]	Bus length l [m]	Length of stub line a [m]	Overall length of all stub lines [m]
1000	10	1.5	7.5
500	70	5.5	27.5
250	115	11	55

The following table provides an approximate overview of the size of the terminating resistor  $R_T$  with different cable lengths. In each specific case, details of the characteristic impedance can be found in the cable specification.

Bus length l [m]	Terminating resistor $R_T$ [Ohm]
0 - 40	120
40 - 300	150 - 300
300 - 500	150 - 300



**INFORMATION**

Please also refer to the installation guidelines published by the CANopen User Group.

**7.5.5**

**CANopen X52**

Connector X52	Pin	Designation	Description
	1	n. c.	n. c.
	2	CAN_L	CAN low signal
	3	GND	Ground
	4	n. c.	n. c.
	5	n. c.	n. c.
	6	n. c.	n. c.
	7	CAN_H	CAN high signal
	8	n. c.	n. c.
n. c. = not connected			

## 7.6 Encoder

Connection cable for external encoder

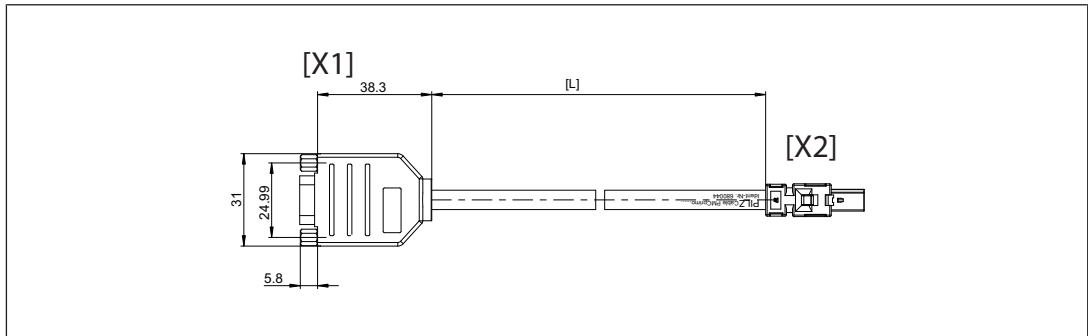

Fig.: Cable PMCprimo mini-IO enc SubD9, order number 680044 (see accessories)

### Legend

- [X1] SubD 9-pin female connector
- [X2] Mini I/O connector
- L Length 0.75 m

### 7.6.1 Supply voltage



#### WARNING!

##### Electric shock!

Safe electrical isolation must be ensured for the external power supply that generates the supply voltage. Failure to do so could result in electric shock. The power supplies must comply with EN 62368-1, EN 61558-2-6, 08:2009.



#### CAUTION!

##### Risk of material damage by applying the supply voltage

Do not connect the supply voltage for the encoder when the encoder input is used in emulation mode (as an output).

See information on [encoder emulation](#) [ 27].

Connector X40a	Pin	Designation	Description
	2	Encoder Supply	Supply voltage for external encoder
	4	0 V Encoder Supply	Supply voltage for external encoder (0 V)
	Supply voltage for encoder at X41		

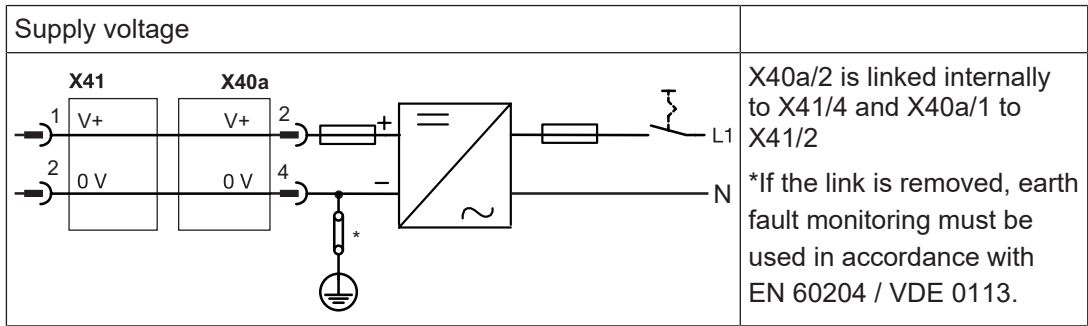

Connector X50a, X50b	Pin	Designation	Description
	2	Encoder Supply	Supply voltage for external encoder
	4	0 V Encoder Supply	Supply voltage for external encoder (0 V)
Supply voltage for encoder at X55 and X56			

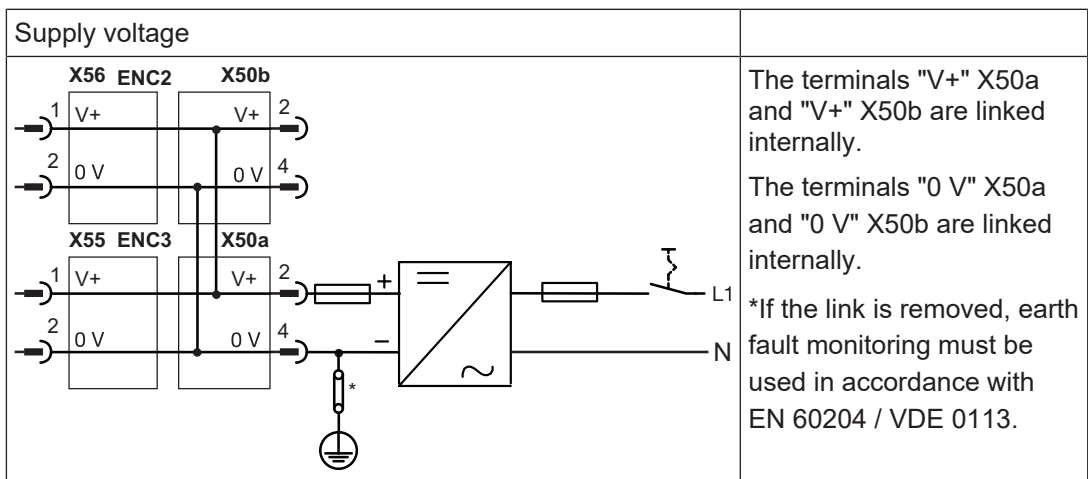

### 7.6.2 Incremental encoder with TTL signal

If the cable length is > 50 m, please speak to our Customer Support.

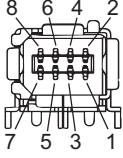
Mini-I/O socket X41, X55, X56	Pin	Designation	Description
	1	V+	Supply voltage
	2	0 V	Supply voltage 0 V
	3	T	Reference pulse Z
	4	A	Channel A
	5	A\	Channel A inverted
	6	Z\	Reference pulse Z inverted
	7	B	Channel B
	8	B\	Channel B inverted
	---	Shield	Shield
	n. c. = not connected		

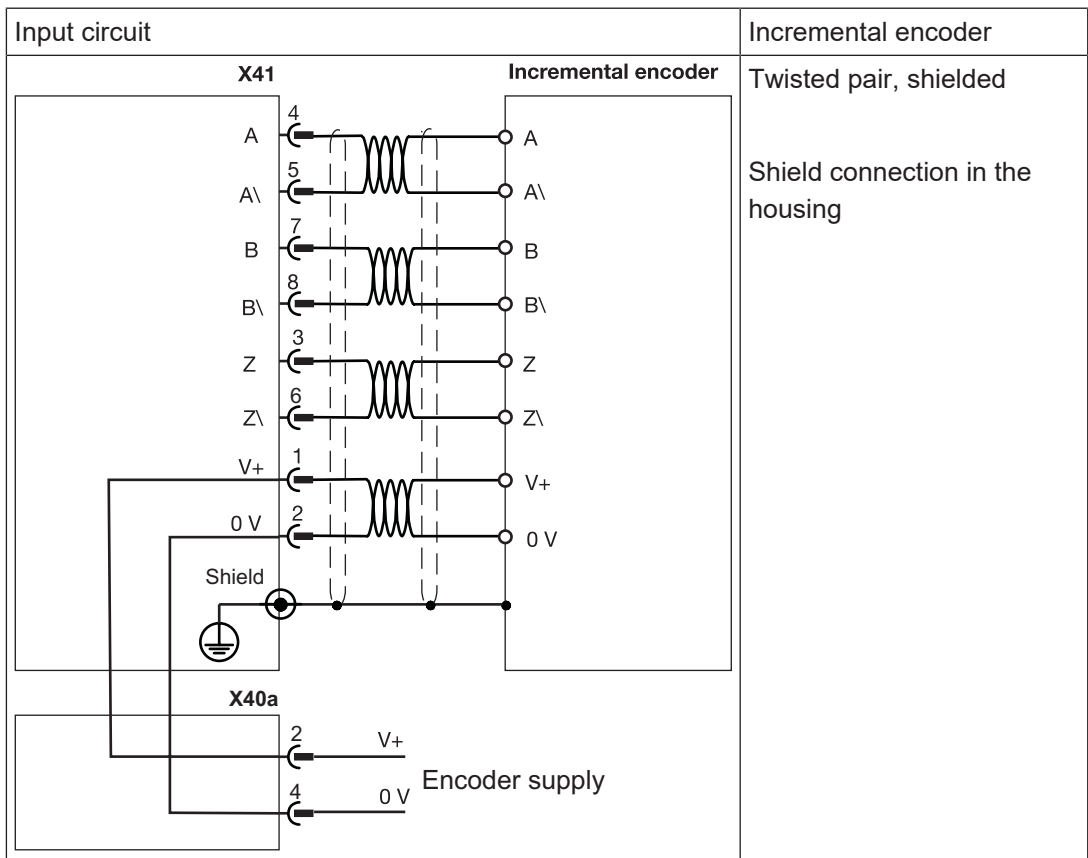

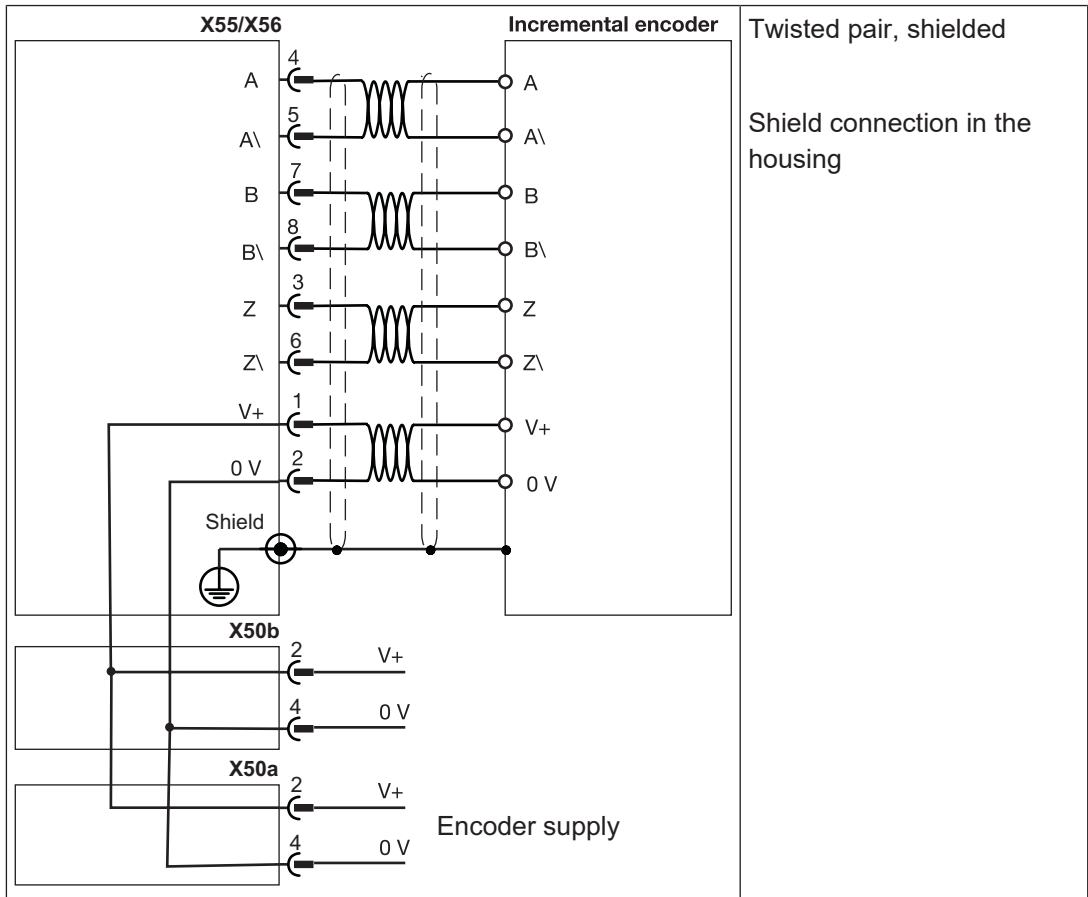

### 7.6.3 Absolute encoder with SSI interface

If the cable length is > 50 m, please speak to our Customer Support.

Mini-I/O socket X41, X55, X56	Pin	Designation	Description
	1	V+	Supply voltage
	2	0 V	Supply voltage 0 V
	3	n. c.	---
	4	CLOCK	Pulse signal
	5	CLOCK\	Pulse signal inverted
	6	n. c.	---
	7	DATA	Data
	8	DATA\	Data inverted
	---	Shield	Shield
n. c. = not connected			

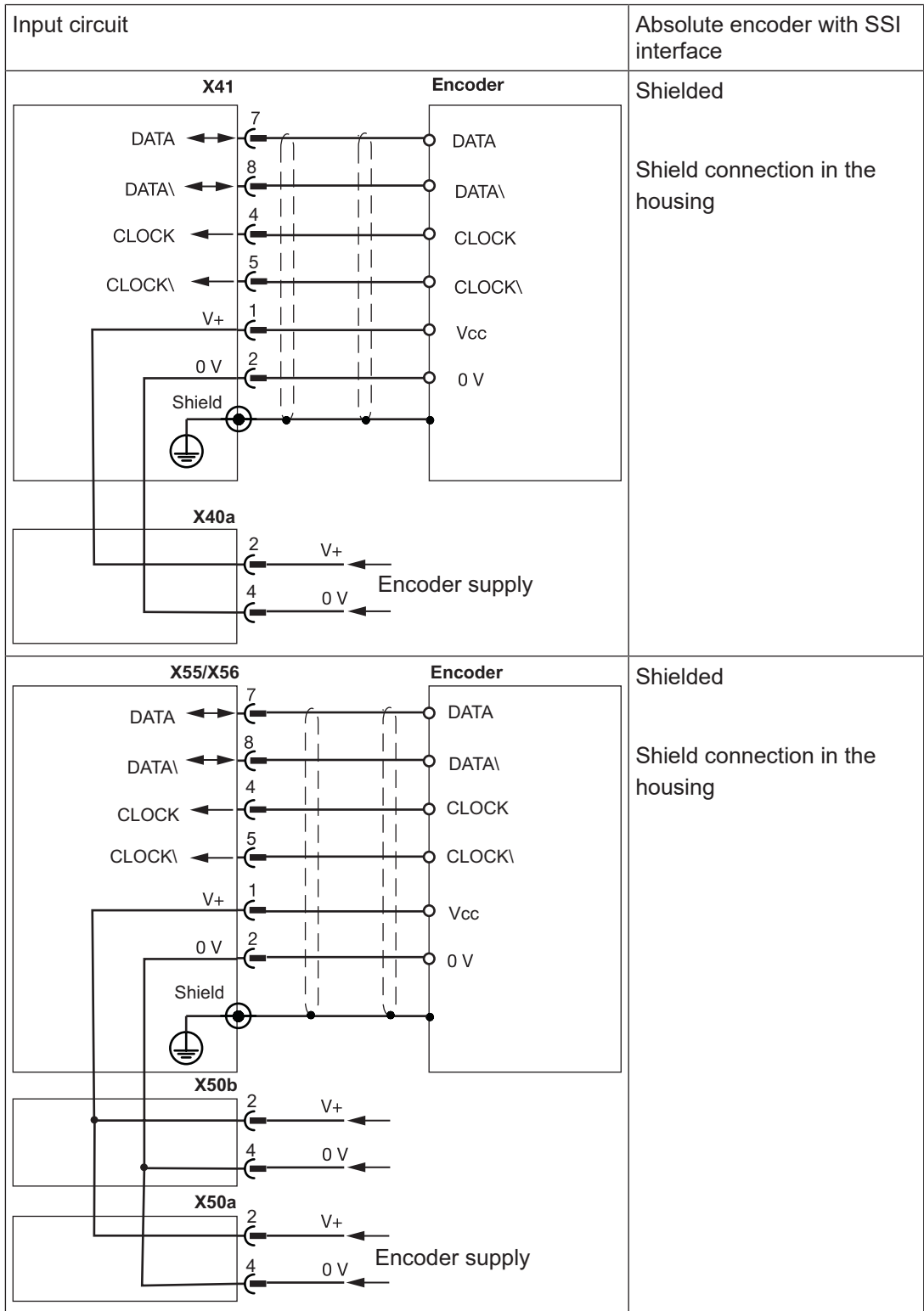

## 8 Commissioning

### 8.1 Safety guidelines

This chapter describes the communication between a PMCprimo MC and a servo amplifier PMCprotego D during initial commissioning.

Further information on commissioning the servo amplifier can be found in the operating manual.

Please note the following safety guidelines during commissioning:

- ▶ When commissioning, you must ensure that the control systems do not present a risk to persons, plant or machinery. Appropriate protection and precautionary measures must be put in place.
- ▶ To avoid personal injury and material damage, only qualified, trained personnel should work on the devices. Qualified technical staff are those who are familiar with the transport, installation, commissioning, maintenance and operation of the device. They will be familiar with the relevant standards and regulations.
- ▶ Prior to commissioning the machine manufacturer must produce a hazard analysis for the machine and take appropriate measures to ensure that unexpected movements do not cause injury to people or damage to equipment.
- ▶ Only specialist staff with extensive knowledge of drive technology and control engineering should be permitted to program a running drive online.
- ▶ Data stored on data media is not protected from unintended changes by third parties. Data must be checked for accuracy before it is downloaded to the control system.
- ▶ Prior to installation and commissioning, information in this operating manual, and in particular the safety guidelines, must be carefully read and considered (see Chapter entitled "Safety"). Personal injury and material damage may result if devices are handled incorrectly.
- ▶ It is essential to comply with the technical details and specifications (type label and documentation).

## 8.2 Commissioning the PMCprimo MC

### 8.2.1 Preparing for commissioning PASmotion

Install the commissioning software PASmotion. The software is available on [www.pilz.com](http://www.pilz.com).

#### Example 1 via CANopen interface: Connect PMCprimo MC and PMCprotego D

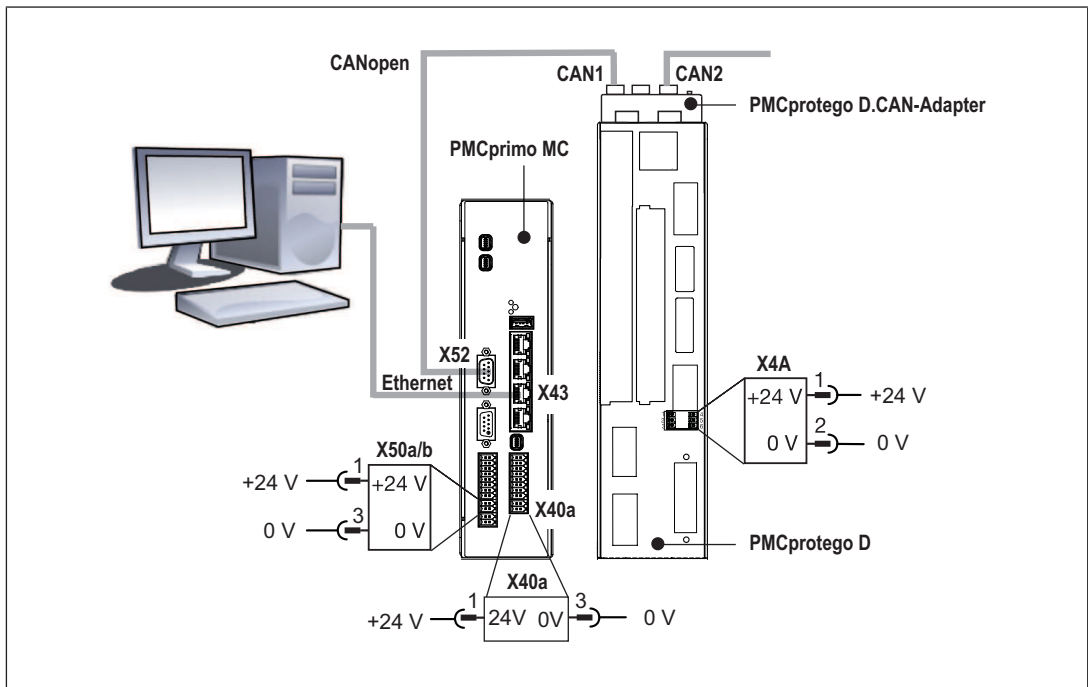

Fig.: Connect PMCprimo MC and PMCprotego D, example 1 via CANopen interface

Prerequisites:

- ▶ A fieldbus junction box PMCprotego D.CAN Adapter is inserted.

Establish the following connections:

- ▶ Connect X52 on the motion controller to X6B on the fieldbus junction box.
- ▶ Connect the Ethernet interface X43 on the motion controller to the PC.

### Example 2 EtherCAT interface: Connect PMCprimo MC and PMCprotego D

The EtherCAT interface is available from Hardware Version 04, see [Type label](#) [11].

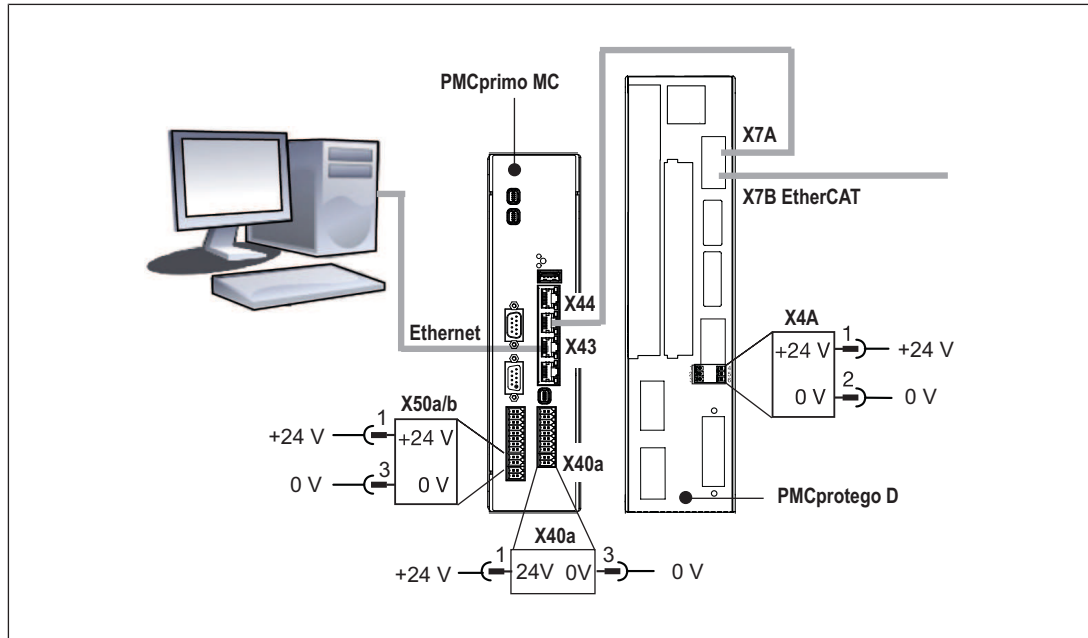

Fig.: Connect PMCprimo MC and PMCprotego D, example 2 via EtherCAT interface

### Connect PMCprimo MC and PMCprotego D

Establish the following connections:

- ▶ Connect X44 on the motion controller to X7A on the PMCprotego Ds.
- ▶ Connect the Ethernet interface X43 on the motion controller to the PC.

### Connect the supply voltages

- ▶ Servo amplifier:
  - PMCprotego D.01 ... D.24
    - X4A/1: 24 V,
    - X4A/2: 0 V,
  - PMCprotego D.48 or PMCprotego D.72
    - X4/1: 24 V,
    - X4/3: 0 V,
- ▶ PMCprimo MC:
  - X40a/1: 24 V,
  - X40a/3: 0 V,

### Apply the supply voltages

- ▶ Switch on the supply voltages for the motion controller and the servo amplifier's control element.

The devices start. The motion controller PMCprimo MC scans the network for subscribers. Logical axes are automatically assigned to the servo amplifiers in the motion controller if

- ▶ No configuration is stored on the motion controller

- ▶ New servo amplifiers are detected in the existing configuration

## 8.2.2 Establish communication between PMCprimo MC and PC

The following steps describe how to establish a connection between the PC and motion controller via the Ethernet interface.

Prerequisite:

- ▶ The commissioning software PASmotion is installed on the PC.
- ▶ The supply voltages (24 VDC) must be present on the servo amplifier and PMCprimo MC.
- ▶ The configuration PC must be connected to the Ethernet interface X43 on the PM-Cprimo MC.

### Establish connection

1. Start the commissioning software PASmotion.
2. Select the **Terminal** window.

3. Click on the  icon - **Create New Connection**.

The **Connection Settings** window opens.

You can now connect to a known network subscriber. If you do not know the IP address, you can browse the network for subscribers.

#### Alternative 1: The IP settings are known

- ▶ Prerequisite: The PMCprimo MC and PC must be in the same network or be accessible via a Router.

1. Select **Ethernet**.

The **New Connection** window opens.

2. Enter the **IP address** in the connection settings and select **Finish**.

The connection to the PMCprimo MC is established.

#### Alternative 2: The IP settings are unknown

- ▶ Prerequisite: The PMCprimo MC and the PC are in the same broadcast domain.

1. Select **Ethernet**.

2. From the list, select the subscriber to which you wish to connect.

Reference: Click on **Ping** to identify the device's hardware.

3. Select **Configuration...** The **Device Configuration** window opens.

4. Enter the IP settings and then select **Use this IP address**. The **Connection Wizard** window opens.

5. Select **Finish**.

The network subscriber is connected.

The motion controller reports on the configuration, once the Ethernet connection has been established.

### S T A R T

#### SOFTWARE

Firmware: 03.05.01, Oct 15 2018, 09:01:35  
Motion: INSTALLED  
IEC PLC: INSTALLED  
Interpolation: INSTALLED

#### ETHERNET

IP address: 192.168.0.11  
Netmask: 255.255.255.0  
Gateway: 192.168.0.1

#### CHANNEL

Number: 1...32

#### HARDWARE

Type: PMCprimo MC 1300MHz 4xCAN  
Item No.: 680080  
Ser. No.: 100033  
Pr. Ver.: 1.0  
Encoder: 3  
Inputs: 16  
Outputs: 16  
Virtual inputs: 56  
Virtual outputs: 56  
Analogue inputs: 0  
Analogue Outputs: 0

#### DEVICES in CAN Network:

PMctendo DD4 (SD01) at CAN4 ADDR 6 found (DS402)

Inputs: 2  
Outputs: 0

The motion controller is ready for operation. It reports with the command prompt 0.1: Key:

Character	Meaning	Details	
0	Address of the controller (always 0 on PM-Cprimo MC)		
.	Decimal point		
1	Number of current axis		
:	Status indicator of current axis	>	Control loop closed
		:	Control loop open
		A	Axis executes alignment movement
		C	Axis executes coupling process
		I	Initialisation running
		M	Axis executes positioning
		S	Axis executes stop command
		V	Axis is in speed control
		W	Axis is in standby
		X	Position assignment is active on the axis

### 8.2.3 Adapt basic configuration

The commissioning software PAS motion in the terminal program can be used to change the basic configuration of the motion controller using the "CD" command.



**INFORMATION**

The encoder interface ENC1 can be assigned an axis number via the basic configuration of the PMCprimo MC. (PTERM, command CD:27). For example, if the ENC1 is assigned the axis number 3, ENC2 and ENC3 are automatically assigned the subsequent axis numbers (axis number 4 and 5). As a result, interfaces ENC2 and ENC3 cannot be freely assigned. Examples in the following table: "(27) Channel for encoder": 1 → ENC1 is assigned to axis number 1.

0.1: cd

0.1:

A C T U A L C O N F I G U R A T I O N :

Operate Mode	Standalone
(24) Cycle Time:	1000 µs
( 4) Actual IP address:	192.168.0.11
( 4) Actual Netmask:	255.255.255.0
( 4) Actual Gateway:	192.168.0.1
(12) Number of Channels:	32
(27) Channel for encoder:	1
( 9) CAN node address	50
( 3) CAN1 baudrate:	1000 KBit
( 8) CAN1 cycle time:	4 ms
(21) CAN2 baudrate:	1000 KBit (equal CAN1)
(23) CAN2 cycle time:	4ms (equal CAN1)
(30) CAN3 cycle time:	4ms (equal CAN1)
(31) CAN3 baudrate:	1000 KBit (equal CAN1)
(32) CAN4 cycle time:	4ms (equal CAN1)
(33) CAN4 baudrate:	1000 KBit (equal CAN1)
(22) CAN-mode: CAN1:	Master CAN2: Master
(26) PMCprotego with SD-Card:	automatic
(34) PROFIBUS/CAN:	CAN
(28) Modbus Client:	Not active

Operate Mode	Standalone

\*\*\*\*\*

```

0: Exit menu
2: Delete application data
3: Change CAN1 baudrate
4: Change Ethernet
8: Set CAN1 Cycle time
9: Set CAN address
12: Change number of channels
21: Change CAN2 baudrate
22: Enable slave mode for CAN1/2
23: Set CAN2 cycle time
24: Change cycle time of system
26: Set address for PMCprotego with SD-Card
27: Change channel for encoder
28: Set number of ModbusClient
29: Change ModbusClient Parameter
30: Set CAN3 cycle time
31: Change CAN3 baudrate
32: Set CAN4 cycle time
33: Change CAN4 baudrate
34: Activate PROFIBUS/CAN
Choice [Return; ESC exits menu]:
    
```

Once you exit the menu the basic configuration is active and saved, if changes have been made. You may be prompted to restart for the changes to take effect.

### 8.2.4 Configure servo amplifier

Parameters for the servo amplifiers available in the network can be set using the commissioning software PASmotion.

Please note the following prerequisites:

- ▶ The servo amplifier must not be enabled (ENABLE = 0).
- ▶ The mains voltage for the servo amplifier's power element must be switched off.
- ▶ The 24 VDC supply voltage for the servo amplifier's control element must be present.
- ▶ The CANopen network must be configured for the motion control system and servo amplifier

Further information is available in the operating instructions for the servo amplifier.

## 8.2.5 Operate PMCprimo MC HW1 - Show Hardware

You can operate the motion controller in the commissioning software terminal by issuing commands in the command language.

### HW1 - Show Hardware

```
0.1: hw1
0.1:
SOFTWARE
    Firmware:      03.05.01, Oct 15 2018, 09:01:35
    Motion:        INSTALLED
    IEC PLC:       INSTALLED
    Interpolation: INSTALLED

ETHERNET
    IP address     192.168.0.11
    Netmask        255.255.255.0
    Gateway        192.168.0.1

CHANNELS
    Number         1...32

HARDWARE
    Type:          PMCprimo MC 1300MHz 4xCAN
    Item No.:      680080
    Ser. No.:      100033
    Pr. Ver.:      1.0
    Encoder:       3
    Inputs:        16
    Outputs:       16
    Virtual in-   56
    puts:
    Virtual out-  56
    puts:
    Analogue in-  0
    puts:
    Analogue Out- 0
    puts:

DEVICES in CAN Network:

    PM Ctendo DD4 (SD01) at CAN4 ADDR 6 found (DS402)
    Inputs:       2
```

Outputs: 0

DEVICES in EtherCAT Network:

PMCprotego D (S706) at EtherCAT ADDR 51 found (DS402)

Inputs: 5

Outputs: 1

Virtual in- 17

puts:

Virtual out- 19

puts:

Analogue in- 2 inputs linked to channel from 0.1 to 0.2

puts:

## 8.2.6 Operate PMCprimo MC HW2 - Show hardware HW2 - Show Hardware State

0.1: HW2

0.1:

STATE OF DEVICES:

Device	Network	Addr	CH	FS	VN	State
PMCprimo MC	---	---	---	---	03.05.00	ACTIVE
PM Ctendo DD4	CAN4	6	---	---	5.180	FAULT
PMCprotego D	ECAT	51	---	---	6.22	ACTIVE

## 8.3 Install CODESYS

The development environment for programming in accordance with IEC 61131-3 CODESYS can be found in the software package "PMC Programming Tool". The software package is available on the Internet at [www.pilz.de](http://www.pilz.de).

After downloading

- ⇒ Unpack the Zip file,
- ⇒ Start the installation program.

The PMCprimo Target Package is installed.

## 9 Operation

### 9.1 Operating states and changes in operating status

#### 9.1.1 Status graph

The following status graph shows the operating states and changes in operating status. The priority of a transition is indicated by a number in a small square in the middle of the transition arrow. The operating states and changes in operating status are described in detail below.

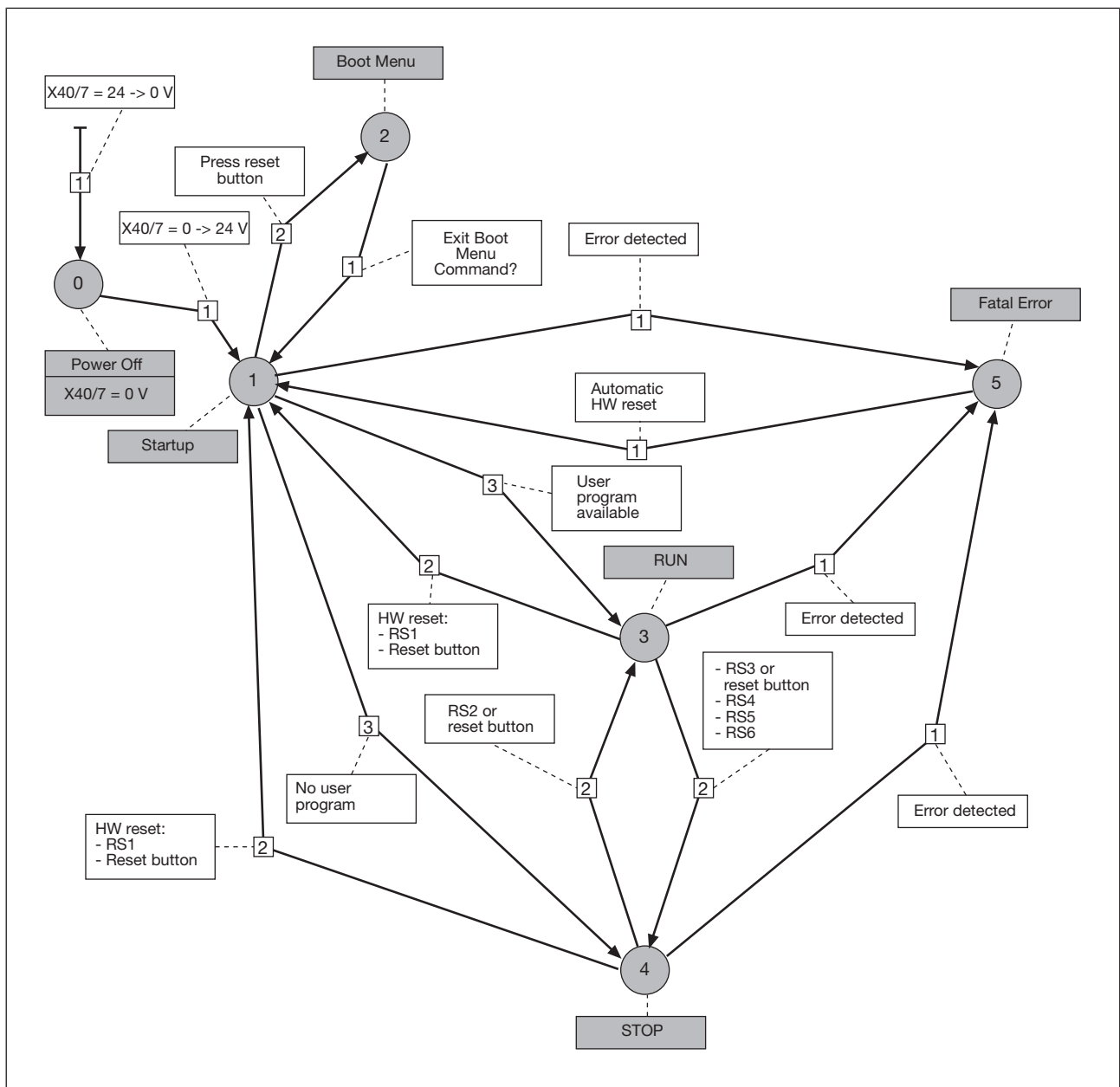

Fig.: Operating states and changes in operating status of the motion controller

## 9.1.2 Operating states

### 9.1.2.1 "Power Off" operating status

In the "Power Off" operating status, the motion controller is voltage-free. By switching on the supply voltage, the system changes to the "Startup" operating status.

### 9.1.2.2 "Startup" operating status

The following steps are performed in the "Startup" operating status:

- ▶ Initialise hardware
- ▶ Initialise fieldbus interfaces
- ▶ Load operating system
- ▶ Load user program

If no errors are detected during "Startup", the controller changes to

- ▶ "RUN" status, if a user program has been loaded.
- ▶ "STOP" status, if **no** user program has been loaded.

Status of LEDs:

- ▶ "STAT" LED flashes yellow, "FUNC" LED off: "Startup" operating status active
- ▶ "STAT" LED flashes green for 4 s when startup has been run. During this time it's possible to change to "Boot Menu" operating status.

Change to "Boot Menu":

- ▶ Press the reset button while the "STAT" LED flashes green.

### 9.1.2.3 "Boot Menu" operating status

In the "Boot Menu" operating status, the operating parameters for the motion controller can be configured in the command language in the terminal program using the CD command, e.g.

- ▶ Configuration of the interfaces
- ▶ Deletion of the user program

Prerequisite:

- ▶ The PC and motion controller must be connected via the Ethernet interface.

Status of LEDs:

- ▶ "STAT" LED: Flashes green
- ▶ "FUNC" LED: Lights up yellow

### 9.1.2.4 "RUN" operating status

In "RUN" operating status

- ▶ All system sections are in a RUN condition and are operating without error.
- ▶ A PLC user program is run as part of each cycle.
- ▶ It is possible to communicate with the motion controller in the terminal program via the command language.

Status of LEDs:

- ▶ The "STAT" and "FUNC" LEDs light up green.

### 9.1.2.5 "STOP" operating status

In "STOP" operating status

- ▶ No PLC user program is run.
- ▶ The system is operating without error.
- ▶ It is possible to communicate with the motion controller in the terminal program via the command language.

Status of LEDs:

- ▶ "STAT" LED: Lights up green
- ▶ "FUNC" LED: Off

### 9.1.2.6 "Fatal Error" operating status

"Fatal Error" operating status is reached when an error occurs.

- ▶ The function is disrupted long-term.
- ▶ The error is entered in the error stack.

Status of LEDs:

- ▶ The "STAT" and "FUNC" LEDs light up red.

## 9.1.3 Change in operating status

-->  **All operating states change to "Power Off"**

The system changes to "Power Off" operating status when the 24 VDC supply voltage has been switched off.

 -->  **Change from "Power Off" to "Startup"**

The system changes to "Startup" operating status when the 24 VDC supply voltage has been switched on.

 -->  **Change from "Startup" to "Boot Menu"**

The "STAT" LED flashes green for 4 s, if the "Startup" operating status has been run without error.

- ▶ Press the reset pushbutton during this time to change to "Boot Menu" operating status.

 -->  **Change from "Startup" to "RUN"**

"Startup" operating status has been run without error. The system changes to "RUN" status if a user program was loaded in "Startup" status.

 -->  **Change from "Startup" to "STOP"**

"Startup" operating status has been run without error. The system changes to "STOP" status if **no** user program was loaded in "Startup" status.

1 --> 5 **Change from "Startup" to "Fatal Error"**

The system changes to "Fatal Error" status if an error occurred in "Startup" status.

2 --> 1 **Change from "Boot Menu" to "Startup"**

The system changes to "Startup" status if the "Boot Menu" in the terminal program is exited using the command O or ESC.

3 --> 1 **Change from "RUN" to "Startup"**

The system performs a hardware reset after

- ▶ Running the command RS1 in the terminal program (cold start).
- ▶ Holding down the reset pushbutton for a long period (> 4 s) (alternative to RS1 command).

3 --> 4 **Change from "RUN" to "STOP"**

The system performs this status change after

- ▶ Running the following commands in the terminal program:
  - RS3 (change to "STOP")
  - RS4 (warm reset), stops the user program
  - RS5 (cold reset), stops the user program
  - RS6 (original reset), deletes the user program
- ▶ Running commands in the IEC 61131 development environment.
- ▶ Holding down the reset pushbutton for a short period (< 4 s) (alternative to RS3 command, change to "STOP").

3 --> 5 **Change from "RUN" to "Fatal Error"**

The system changes to "Fatal Error" operating status if an error occurred in "RUN" status.

Remedy

- ▶ Perform hardware reset (cold start)
- ▶ Contact Pilz.

4 --> 1 **Change from "STOP" to "Startup"**

The system performs a hardware reset after

- ▶ Running the command RS1 in the terminal program (cold start).
- ▶ Holding down the reset pushbutton for a long period (> 4 s) (alternative to RS1 command (cold start)).

4 --> 3 **Change from "STOP" to "RUN"**

The system performs this status change after

- ▶ Running the command RS2 in the terminal program (change to "RUN").
- ▶ Running commands in the IEC 61131 development environment:

- ▶ Holding down the reset pushbutton for a short period (< 4 s) (alternative to RS2 command (change to "RUN")).

**4 --> 5 Change from "STOP" to "Fatal Error"**

The system changes to "Fatal Error" operating status if an error occurred in "STOP" status.

Remedy

- ▶ Perform hardware reset (cold start)
- ▶ Contact Pilz.

## 9.2 Reset, restart, start and stop options

### 9.2.1 Overview

Various options are available to specifically stop or start the motion controller, for operation or commissioning for example. The implications of intervening depend on the specific command that is used.

Options	Action	Command language	IEC 61131 programming
Cold start motion controller	Cold start (HW reset)	RS1 (alternative: Hold down reset pushbutton for long period (> 4 s))	
Stop user program	Stop	RS3 (alternative: Hold down reset pushbutton for short period (< 4 s))	Online --> Stop
Start user program	Start	RS2 (alternative: Hold down reset pushbutton for short period (< 4 s))	Online --> Start
Reset motion controller	Cold reset	RS5	Online --> Reset (cold)
	Warm reset	RS4	Online --> Reset
	Original reset	RS6	Online --> Reset (original)

The following table provides an overview of the impact of a reset, start or stop on a variable.

Action	Variable with attribute RETAIN	Variable with attribute PERSISTENT	Variable with attribute RETAIN PERSISTENT
Warm reset	x	-	x
Cold reset	-	-	-
Original reset	-	-	-

x = Value is retained, - = Value is re-initialised

## 9.2.2 Cold start, "Startup"

A reset via the "Power Off" operating status performs a system cold start with "Startup".

- ▶ Switch the 24 VDC supply voltage to the motion controller off and then on again.
- ▶ The motion controller changes to "Startup" operating status.

## 9.2.3 Reset commands

### 9.2.3.1 Warm reset

This command

- ▶ Stops the user program.
- ▶ Resets all variables to the value with which they were initialised (exception: variable with attribute RETAIN).
- ▶ Resets all variables that have not been explicitly initialised to a default initialisation value.

Commands:

- ▶ Command language: RS4
- ▶ IEC 61131 programming: Menu **Online -> Reset**

### 9.2.3.2 Cold reset

This command

- ▶ Stops the user program.
- ▶ Resets all variables to the value with which they were initialised.

Commands:

- ▶ Command language: RS5
- ▶ IEC 61131 programming: Menu **Online -> Reset (cold)**

### 9.2.3.3 Original reset

This command

- ▶ Deletes the user program.
- ▶ Resets all variables to the value with which they were initialised (including remanent variables with attribute RETAIN and PERSISTENT).
- ▶ Resets the motion controller to its original condition (factory default settings).

Commands:

- ▶ Command language: RS6
- ▶ IEC 61131 programming: Menu *Online* -> *Reset (original)*

## 9.3 Functions of the reset button

The "RESET" button is mounted in a recess on the front of the unit. It can only be accessed using an appropriate tool (e.g. a pin).

The following actions can be triggered by pressing the "RESET" pushbutton:

- ▶ Change from "Startup" operating status to "Boot Menu"
- ▶ Hardware reset (cold start): Change from "RUN" or "STOP" operating status to "Startup"
- ▶ Change from "RUN" operating status to "STOP"
- ▶ Change from "STOP" operating status to "RUN"
- ▶ A USB stick must be inserted: the data stored on the USB stick is copied to the controller. The data can contain a new firmware with a complete project.

### Change from "Startup" operating status to "Boot Menu"

After cold starting the motion controller you can change to the "Boot Menu" in order to set the operating parameters.

Follow the instructions below:

- ▶ The controller is in "Startup" operating status. LED flashes rapidly.
- ▶ The LED lights for 4 s continuously after "Startup" operating status has been run. During this time it's possible to change to "Boot Menu" operating status.
- ▶ Press the reset pushbutton while the LED is lit continuously.
- ▶ The controller changes to "Boot Menu".

### Hardware reset (cold start)

A hardware reset can be triggered in "RUN" or "STOP" operating status. The controller changes to "Startup" operating status.

Follow the instructions below:

- ▶ The controller is in "STOP" or "RUN" operating status.
- ▶ Hold the reset pushbutton down for at least 4 s.
- ▶ The controller changes to "Startup".

### Changing between the operating states "RUN" and "STOP"

You can change between the operating states "RUN" and "STOP".

- ▶ Briefly press the reset pushbutton to change from "RUN" to "STOP" or from "STOP" to "RUN".

## 9.4 Messages

The motion controller provides many options for diagnostics, fault detection and communication with other controllers.

Diagnostics can be performed via

- ▶ The LEDs on the front of the device.
- ▶ The error stack.
- ▶ PVIS expanded diagnostics.
- ▶ Display commands.
- ▶ Recording of process data.

### LEDs

LEDs on the front of the device provide information on the operating status (see section on "Display elements" in this chapter).

### Error stack

The error stack contains the last 100 error messages. It can be read in the operating status "RUN" and "STOP".

- ▶ Select the LE1 command in the terminal program.

### PVIS

Errors, messages and the corresponding remedies are displayed in the expanded diagnostics system PVIS.

### Display commands

Display commands for recording process data are axis-related. They are used to display motion control data, e.g. position, speed, tracking distance. Display commands can be executed in the operating status "RUN" and "STOP".

- ▶ To start display mode, select the DM command in the terminal program.
- ▶ To end display mode, select the DO command in the terminal program.





















### Process data

Process data can be recorded in the operating status "RUN" and "STOP" via the



- ▶ Motion controller.
- ▶ Terminal program.
- ▶ Oscilloscope function PScope.







## 9.5 Display elements



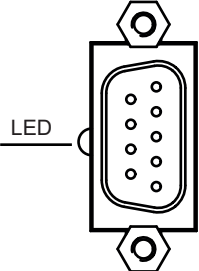

The motion controller has two multi-coloured "STAT" and "FUNC" LEDs for displaying the operating status.



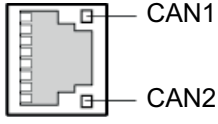

STAT	FUNC	Description
 Yellow	 Yellow	Firmware update is running
 Yellow		"Startup" operating status active
 Green		Reset button can be pressed in order to perform an action (4 s duration)
 Green	 Yellow	Controller is in "Boot Menu" status
 Green	 Green	Controller is in "Startup" status
 Red	 Red	Fatal error, "Fatal Error" status
 Green	 Green	Controller is in "RUN" status
 Green		System is in "STOP" status
 Green	 Blue	Identification (Ping)
 Blue	 Blue	Data storage for device exchange (see <a href="#">USB [25]</a> )

► Legend

	LED on
	LED off
	LED flashes

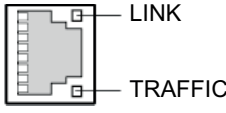
LED	Meaning				
 <p>X51, X52</p>	<table border="1"> <tr> <td> Green</td> <td>Network connection</td> </tr> <tr> <td></td> <td>No network connection</td> </tr> </table>	 Green	Network connection		No network connection
	 Green	Network connection			
	No network connection				
<p>CAN3 CAN4</p>					

LED		Meaning	
 <p>X42</p>	CAN1	 Green	Network connection
			No network connection
	CAN2	 Yellow	Network connection
			No network connection

LED		Meaning	
 <p>X43, X44, X45</p>	LINK	 Green	Network connection
			No network connection
	TRAFFIC	 Yellow	Data traffic
			No data traffic

## 10 Technical details

<b>General</b>	
Certifications	<b>CE, UKCA, cULus Listed</b>
<b>Electrical data</b>	
Supply voltage	
for	<b>Supply</b>
Voltage	<b>24 V</b>
Kind	<b>DC</b>
Voltage tolerance	<b>-15 %/+20 %</b>
Output of external power supply (DC) at no load	<b>14,4 W</b>
Max. power dissipation of module	<b>20 W</b>
<b>CPU</b>	
Memory for applications	<b>256 MB</b>
Processor clock speed	<b>1,3 GHz</b>
Typ. processing time/1000 instructions	<b>2 µs</b>
Working memory (RAM)	<b>512 MB</b>
Non-volatile ST memory	<b>32 KB</b>
<b>Absolute encoder input</b>	
Number of counter inputs	<b>3</b>
Type of counter inputs	<b>SSI encoder</b>
Connection type	<b>Mini-IO female connector, 8-pin</b>
Supply voltage for absolute encoder	<b>10 ... 30 VDC</b>
Output signal (clock)	<b>Differential signal (RS-422/TTL)</b>
Max. number of bits on the counter input	<b>12 - 32 Bit</b>
Transmission rate	<b>300 kHz</b>
Coding of the input signal	<b>Binary, Gray</b>
Signal at the data input	<b>Differential signal (RS-422/TTL)</b>
Potential isolation	<b>yes</b>
<b>Incremental encoder input</b>	
Number of inputs	<b>2 - 3</b>
Connection type	<b>Mini-IO female connector, 8-pin</b>
Supply voltage for incremental encoders	<b>10 ... 30 VDC, 4,75 ... 5,25 VDC</b>
Phase position for the differential signals A, /A and B, /B	<b>90° ±30°</b>
Maximum cutoff frequency	<b>0,5 MHz</b>
<b>Encoder emulation</b>	
Max. output frequency	<b>250 kHz</b>
Max. output current	<b>10 mA</b>
Max. jitter	<b>1000 incr./s</b>
<b>Inputs</b>	
Number	<b>16</b>
Input filter depending on parameter settings	<b>5 µs, 600 µs</b>
Signal level at "0"	<b>-3 - +5 V DC</b>

<b>Inputs</b>	
Signal level at "1"	<b>15 - 30 V DC</b>
Input voltage in accordance with EN 61131-2 Type 1	<b>24 V DC</b>
Input current range	<b>3,5 - 10,8 mA</b>
Potential isolation	<b>yes</b>
<b>Semiconductor outputs</b>	
Number of positive-switching single-pole semiconductor outputs	<b>16</b>
External supply voltage	<b>24 V</b>
Voltage tolerance	<b>-15 %/+20 %</b>
Typ. output current at "1" signal and rated voltage of semiconductor output	<b>0,5 A</b>
Permitted current range	<b>0,5 A</b>
Potential isolation	<b>yes</b>
Short circuit-proof	<b>yes</b>
Permitted loads	<b>inductive, capacitive, resistive</b>
<b>PROFIBUS-DP interface</b>	
Number	<b>1</b>
Device type	<b>Slave</b>
Station address	<b>0 ... 126d</b>
Station address selectable via	<b>Software</b>
Maximum data length of PROFIBUS interface	
Input device	<b>244 Byte</b>
Output	<b>244 Byte</b>
Diagnostics	<b>80 Byte</b>
Connection	<b>9-pin D-Sub female connector</b>
Log	<b>DPV0</b>
Operating modes	<b>AutoBaud</b>
Description file	<b>Pilz0DCC.gsd</b>
Manufacturer's ID	<b>0DCCh</b>
<b>CANopen interface</b>	
Number	<b>3, 4</b>
Connection type	<b>9-pin D-Sub female connector, RJ45</b>
Device type	<b>Master, Slave</b>
Cycle times	<b>–</b>
Transmission rates	<b>1000 kBit/s, 250 kBit/s, 500 kBit/s</b>
Potential isolation	<b>yes</b>
<b>Ethernet interface</b>	
Number	<b>1</b>
IP address, factory setting	<b>192.168.0.11</b>
Connection type	<b>RJ45</b>
Transmission rate	<b>1 Gbit/s</b>
Potential isolation	<b>yes</b>
<b>EtherCAT interface</b>	
Quantity	<b>1</b>

<b>EtherCAT interface</b>	
Connection	<b>RJ45</b>
Transmission rates	<b>100 MBit/s</b>
Potential isolation	<b>yes</b>
<b>Environmental data</b>	
Climatic suitability	<b>EN 60068-2-1, EN 60068-2-14, EN 60068-2-2, EN 60068-2-78</b>
Ambient temperature	
In accordance with the standard	<b>EN 60068-2-14</b>
Temperature range	<b>0 - 40 °C</b>
Storage temperature	
In accordance with the standard	<b>EN 60068-2-1/-2</b>
Temperature range	<b>-40 - 70 °C</b>
Climatic suitability	
In accordance with the standard	<b>EN 60068-2-78</b>
Humidity	<b>93 % r. h. at 40 °C</b>
Condensation during operation	<b>Not permitted</b>
Max. operating height above sea level	<b>2000 m</b>
EMC	<b>EN 61131-2</b>
Vibration	
In accordance with the standard	<b>EN 60068-2-6</b>
Frequency	<b>5 - 8,4 Hz</b>
Amplitude	<b>3,5 mm</b>
Acceleration	<b>10 m/s<sup>2</sup></b>
Shock stress	
In accordance with the standard	<b>EN 60068-2-27</b>
Acceleration	<b>150 m/s<sup>2</sup></b>
Duration	<b>11 ms</b>
Cooling	<b>Built-in fan</b>
Airgap creepage	
In accordance with the standard	<b>EN 61131-2</b>
Overvoltage category	<b>II</b>
Pollution degree	<b>2</b>
Protection type	
In accordance with the standard	<b>EN 60529</b>
Housing	<b>IP20</b>
Terminals	<b>IP20</b>
Mounting area (e.g. control cabinet)	<b>IP54</b>
<b>Potential isolation</b>	
Potential isolation between	<b>Encoder and system voltage</b>
Type of potential isolation	<b>Basic insulation</b>
Rated surge voltage	<b>500 V</b>
Potential isolation between	<b>Ethernet and system voltage</b>
Type of potential isolation	<b>Basic insulation</b>
Rated surge voltage	<b>500 V</b>
Potential isolation between	<b>EtherCAT and system voltage</b>

<b>Potential isolation</b>	
Type of potential isolation	<b>Basic insulation</b>
Rated surge voltage	<b>500 V</b>
Potential isolation between	<b>SC output and system voltage</b>
Type of potential isolation	<b>Basic insulation</b>
Rated surge voltage	<b>500 V</b>
Potential isolation between	<b>Input and system voltage</b>
Type of potential isolation	<b>Basic insulation</b>
Rated surge voltage	<b>500 V</b>
Potential isolation between	<b>CANopen and system voltage</b>
Type of potential isolation	<b>Basic insulation</b>
Rated surge voltage	<b>500 V</b>
<b>Mechanical data</b>	
Material	
Housing	<b>Hot dip galvanised metal</b>
Front	<b>Hot dip galvanised metal</b>
Top	<b>Polyester film</b>
Mounting type	<b>plug-in</b>
Conductor cross section with screw terminals	
Rigid single-core, flexible multi-core or multi-core with crimp connector	<b>0,75 mm<sup>2</sup></b>
Dimensions	
Height	<b>270,6 mm</b>
Width	<b>60 mm</b>
Depth	<b>183 mm</b>
Weight	<b>1.360 g</b>

Where standards are undated, the 2015-05 latest editions shall apply.

## 11 **EC declaration of conformity**

This product/these products meet the requirements of the directive 2006/42/EC for machinery of the European Parliament and of the Council. The complete EC Declaration of Conformity is available on the Internet at [www.pilz.com/downloads](http://www.pilz.com/downloads).

Authorised representative: Norbert Fröhlich, Pilz GmbH & Co. KG, Felix-Wankel-Str. 2, 73760 Ostfildern, Germany

## 12 UKCA-Declaration of Conformity

This product(s) complies with following UK legislation: Supply of Machinery (Safety) Regulation 2008.

The complete UKCA Declaration of Conformity is available on the Internet at [www.pilz.com/support/downloads](http://www.pilz.com/support/downloads).

Representative: Pilz Automation Technology, Pilz House, Little Colliers Field, Corby, Northamptonshire, NN18 8TJ United Kingdom, eMail: [mail@pilz.co.uk](mailto:mail@pilz.co.uk)

## 13 Order reference

### 13.1 Product

Only the basic versions are listed. Please refer to the Type code for expansion details.

Product type	Features	Order no.
PMCprimo MC.C/16DIDO/2/000	Motion controller with CANopen/CANopen interface	680080

### 13.2 Accessories

Product type	Features	Order no.
PMCprotego D.CAN-Adapter 01-24A	Fieldbus junction box for PMCprotego D.01 ... D.24 Two CANopen interfaces: CAN-in, CAN-out, RS232 with termination and monitoring voltage switch	8176300
PMCprotego D.CAN-Adapter 48-72A	Fieldbus junction box for PMCprotego D.48/D.72 Two CANopen interfaces: CAN-in, CAN-out, RS232 with termination and monitoring voltage switch	8176470
PMCprimo DriveP.CAN-CAN Adapter 01-24 (for X42)	Fieldbus junction box for PMCprimo DriveP (Drive: PMCprotego D.01 ... D.24) Two CANopen interfaces: CAN1, RS232 and CAN2 with termination switch and RJ45 cable for connecting the fieldbus junction box to PMCprimo	680040
PMCprimo DriveP.CAN-CAN Adapter 48-72 (for X42)	Fieldbus junction box for PMCprimo DriveP (Drive: PMCprotego D.48 ... D.72) Two CANopen interfaces: CAN1, RS232 and CAN2 with termination switch and RJ45 cable for connecting the fieldbus junction box to PMCprimo	680042

Product type	Features	Order no.
Cable PMCprimo mini-I/O >enc. SubD9 0.75m	Adapter cable 0.75 m Mini-I/O connector - Sub-D socket, 9-pin (for encoder)	680044

<b>Product type</b>	<b>Features</b>	<b>Order no.</b>
MM A MINI-IO CABB99 1.5m	Adapter cable 1.5 m 8-pin Mini-I/O male connector – Stranded wires with fer- rules	772200
MM A MINI-IO CABB99 2.5m	Adapter cable 2.5 m 8-pin Mini-I/O male connector – Stranded wires with fer- rules	772201
MM A MINI-IO CABB99 5.0m	Adapter cable 5 m 8-pin Mini-I/O male connector – Stranded wires with fer- rules	772202

# ► Support

Technical support is available from Pilz round the clock.

## Americas

### Brazil

+55 11 97569-2804

### Canada

+1 888 315 7459

### Mexico

+52 55 5572 1300

### USA (toll-free)

+1 877-PILZUSA (745-9872)

## Asia

### China

+86 21 60880878-216

### Japan

+81 45 471-2281

### South Korea

+82 31 778 3300

## Australia and Oceania

### Australia

+61 3 95600621

### New Zealand

+64 9 6345350

## Europe

### Austria

+43 1 7986263-0

### Belgium, Luxembourg

+32 9 3217570

### France

+33 3 88104003

### Germany

+49 711 3409-444

### Ireland

+353 21 4804983

### Italy, Malta

+39 0362 1826711

## Scandinavia

+45 74436332

## Spain

+34 938497433

## Switzerland

+41 62 88979-32

## The Netherlands

+31 347 320477

## Turkey

+90 216 5775552

## United Kingdom

+44 1536 462203

## You can reach our international hotline on:

+49 711 3409-222

support@pilz.com

Pilz develops environmentally-friendly products using ecological materials and energy-saving technologies. Offices and production facilities are ecologically designed, environmentally-aware and energy-saving. So Pilz offers sustainability, plus the security of using energy-efficient products and environmentally-friendly solutions.



We are represented internationally. Please refer to our homepage [www.pilz.com](http://www.pilz.com) for further details or contact our headquarters.

Headquarters: Pilz GmbH & Co. KG, Felix-Wankel-Straße 2, 73760 Ostfildern, Germany  
Telephone: +49 711 3409-0, Telefax: +49 711 3409-133, E-Mail: [info@pilz.com](mailto:info@pilz.com), Internet: [www.pilz.com](http://www.pilz.com)

**PILZ**  
THE SPIRIT OF SAFETY

1003813-EN-05, 2022-07 Printed in Germany  
© Pilz GmbH & Co. KG, 2019

CECE®, CHRE®, CMSE®, InduraNET p®, Leansafe®, Master of Safety®, Master of Security®, PAS4000®, PAScall®, PASconfig®, Pilz®, PTT®, PLID®, PMCPirimo®, PMCPiritego®, PMCTendo®, PMD®, PMJ®, PNOZ®, PRCM®, PRM®, PRM®, PRM®, PRTM®, PSEN®, PSS®, PVS®, SafetyBUS p®, SafetyEYE®, SafetyNET p®, THE SPIRIT OF SAFETY® are registered and protected trademarks of Pilz GmbH & Co. KG in some countries. We would point out that product features may vary from the details stated in this document, depending on the status at the time of publication and the scope of the equipment. We accept no responsibility for the validity, accuracy and entirety of the text and graphics presented in this information. Please contact our Technical Support if you have any questions.