

Visualisation; Diagnostics

Easy to Configure

Programming IEC 61131-3

Rapid Installation

PROFINET for PM Ctendo DD5 and PM Cprotego D

PILZ
THE SPIRIT OF SAFETY

► Servo amplifiers

This document is a translation of the original document.

All rights to this documentation are reserved by Pilz GmbH & Co. KG. Copies may be made for internal purposes. Suggestions and comments for improving this documentation will be gratefully received.

Source code from third-party manufacturers or open source software has been used for some components. The relevant licence information is available on the Internet on the Pilz homepage.

Pilz®, PIT®, PMI®, PNOZ®, Primo®, PSEN®, PSS®, PVIS®, SafetyBUS p®, SafetyEYE®, SafetyNET p®, the spirit of safety® are registered and protected trademarks of Pilz GmbH & Co. KG in some countries.



SD means Secure Digital

Section 1	Introduction	6	
	1.1	Validity of documentation	6
	1.1.1	Retaining the documentation	6
	1.2	Definition of symbols	6
Section 2	Overview	8	
	2.1	Unit features	8
Section 3	Safety	9	
	3.1	Intended use	9
	3.1.1	Hazard analysis	9
	3.1.2	Electrical data	9
	3.2	Safety during operation	9
	3.3	Safety regulations	9
	3.3.1	Additional documents that apply	9
	3.3.2	Use of qualified personnel	10
	3.3.3	Warranty and liability	10
	3.3.4	Disposal	10
Section 4	Function description	11	
	4.1	Front view	11
	4.2	Device master file	12
	4.3	Interface assignment	13
	4.4	Connection examples	13
	4.4.1	Connection example PROFINET RT	13
	4.4.2	Connection example PROFINET IRT / RT	14
	4.4.3	Connection example IRT <Switch> RT	15
Section 5	Assembly	16	
	5.1	Installing the expansion card in the servo amplifier PM Ctendo DD5	16
	5.2	Installing the expansion card in the servo amplifier PMCprotego	18
Section 6	Wiring	20	
	6.1	Connection technology	20
Section 7	Commissioning	21	
	7.1	Guide to commissioning	21
	7.2	Important configuration parameters	22
	7.3	Commissioning software PASmotion	27
	7.3.1	PROFINET window	27
	7.3.2	PASmotion PROFINET "Settings" tab	27
	7.3.3	PASmotion PROFINET "Device Control" tab	29
	7.4	Setting the device name on PROFINET	29
Section 8	Device profile	30	
	8.1	General	30
	8.2	Parameter channel	31

8.2.1	Parameter identifier PKE	31
8.2.1.1	Meaning of response identifiers	32
8.2.1.2	Profile-specific error numbers with response identifier 7	33
8.2.2	Index IND	34
8.2.3	Parameter value PWE	34
8.3	Process data channel	35
Section 9	Parameter channel	36
9.1	Writing/reading an amplifier parameter	36
9.2	Composition of parameter numbers	36
9.2.1	List of selected parameter numbers	37
9.2.2	Profile parameters	42
9.2.2.1	PNU 970: Default parameter	42
9.2.2.2	PNU 971: Save parameters in non-volatile memory	42
9.2.2.3	PNU 930: Selector switch for operating modes	42
9.2.3	Manufacturer-specific parameters	44
9.2.3.1	PNU 1000: Device ID	44
9.2.3.2	PNU 1001: Manufacturer-specific error register	44
9.2.3.3	PNU 1002: Manufacturer-specific status register	46
9.2.4	Position control parameters	48
9.2.4.1	PNU 1894: Speed multiplier	48
9.2.4.2	PNU 1807: Axis type	48
9.2.5	Positioning data for position controller mode	49
9.2.5.1	PNU 1790: Position	49
9.2.5.2	PNU 1791: Speed	49
9.2.5.3	PNU 1785: Motion task type	49
9.2.5.4	PNU 1783: Acceleration time	51
9.2.5.5	PNU 1786: Delay time	51
9.2.5.6	PNU 1788: Subsequent motion task	51
9.2.5.7	PNU 1789: Start delay	51
9.2.5.8	PNU 1310: Copy motion task	51
9.2.6	Setup mode, position	51
9.2.6.1	PNU 1773 Reference run type	51
9.2.6.2	PNU 1644 Reference run direction	52
9.2.7	Actual values	52
9.2.7.1	PNU 1800: SI position value	52
9.2.8	Digital I/O configuration	52
9.2.8.1	PNUs 1698/1701/1704/1707 Function of the digital inputs	52
9.2.8.2	PNUs 1775/1778 Function of the digital outputs	52
9.2.9	Analogue configuration	52
9.2.9.1	PNU 1607: Configuration of the analogue input functions	52
9.2.10	Manufacturer-specific object channel (from PNU 1600)	52
Section 10	Process data channel	56
10.1	Device control	57
10.1.1	Control word (STW)	59
10.1.2	Status word (ZSW)	62
10.2	Operating modes (Opmodes)	63

10.2.1	Positioning (Opmode 2)	63
10.2.2	Digital speed (Opmode 1)	65
10.2.3	Analogue speed (Opmode -1)	66
10.2.4	Digital torque (Opmode -2)	66
10.2.5	Analogue torque (Opmode -3)	66
10.2.6	Electronic gearing (Opmode -4)	67
10.2.7	Trajectory (Opmode -5)	67
10.2.8	ASCII channel (Opmode -16)	68
10.2.9	Operating mode after power up (Opmode -126)	69
Section 11	Technical details	70
Section 12	Order reference	71
Section 13	Appendix	72
13.1	Setup examples	72
13.1.1	Zero telegram (for initialisation)	72
13.1.2	Setting the operating mode	72
13.1.3	Enabling the servo amplifier	73
13.1.4	Starting jog mode	73
13.1.5	Setting the reference point	73
13.1.6	Starting the reference run	74
13.1.7	Starting a motion task	76
13.1.8	Starting a direct motion task	76
13.1.9	Polling a warning or error message	77
13.1.10	Writing a parameter	77
13.1.11	Reading actual values	77
13.1.12	Writing a parameter via the ASCII channel	77

1 Introduction

1.1 Validity of documentation

This operating manual explains the function and operation, describes the installation and provides guidelines on how to connect the product Erweiterungskarte PROFINET .

This documentation is valid for the products Erweiterungskarte PROFINET . It is valid until new documentation is published.

1.1.1 Retaining the documentation

This documentation is intended for instruction and should be retained for future reference.

1.2 Definition of symbols

Information that is particularly important is identified as follows:



DANGER!

This warning must be heeded! It warns of a hazardous situation that poses an immediate threat of serious injury and death and indicates preventive measures that can be taken.



WARNING!

This warning must be heeded! It warns of a hazardous situation that could lead to serious injury and death and indicates preventive measures that can be taken.



CAUTION!

This refers to a hazard that can lead to a less serious or minor injury plus material damage, and also provides information on preventive measures that can be taken.



NOTICE

This describes a situation in which the product or devices could be damaged and also provides information on preventive measures that can be taken. It also highlights areas within the text that are of particular importance.

**INFORMATION**

This gives advice on applications and provides information on special features.

Abbreviation	Meaning
P1	Port 1
P2	Port 2
BTB/RTO	Ready for operation
EEPROM	Electrically erasable programmable read-only memory
EN	European standard
IEC	International Electrotechnical Commission
LED	Light-emitting diode
MB	Megabyte
NSTOP	Limit switch input, left-hand direction of rotation
PNO	PROFIBUS User Organisation
PSTOP	Limit switch input, right-hand direction of rotation
PZD	Process data
RAM	Volatile memory
PLC	Programmable logic controller
SSI	Synchronous serial interface
VAC	AC voltage
VDC	DC voltage

2 Overview

2.1 Unit features

The PROFINET expansion card provides a PROFINET interface for the servo amplifier PMCprotego D / PMCtendo DD5.

PROFINET is an open fieldbus standard based on Industrial Ethernet. PROFINET communication is defined in the international standards IEC 61158, IEC 61158-5-10 (Application Layer Service Definition), IEC 61158-6-10 (Application Layer Protocol Specification), IEC 61784-1 Type 10 (Communication Profiles) and IEC 61784-2 (PROFINET IO). Further provisions have been defined in specifications published by the user organisation PROFIBUS & PROFINET International (PI).

The PROFINET expansion card

- ▶ is available as an option.
- ▶ has a PROFINET interface.
- ▶ can be configured using the commissioning software "PASmotion"
- ▶ operates with a transmission rate of 100 MBit/s (100Base TX), full and half duplex.
- ▶ displays the status and fault indicators for communication with PROFINET.
- ▶ complies with the PROFINET-IO-Device (V2.31) functions in accordance with Conformance Class A/B.

The servo amplifier supplies the voltage to the expansion card.

The input and output buffer can be monitored in the PASmotion tool.

The PROFINET expansion card supports the following functions:

- ▶ RT
- ▶ Mixed operation (RT, IRT) possible, see [Connection example IRT <Switch> RT](#) [15].
- ▶ LLDP
- ▶ I&M 0
- ▶ I&M 1-4

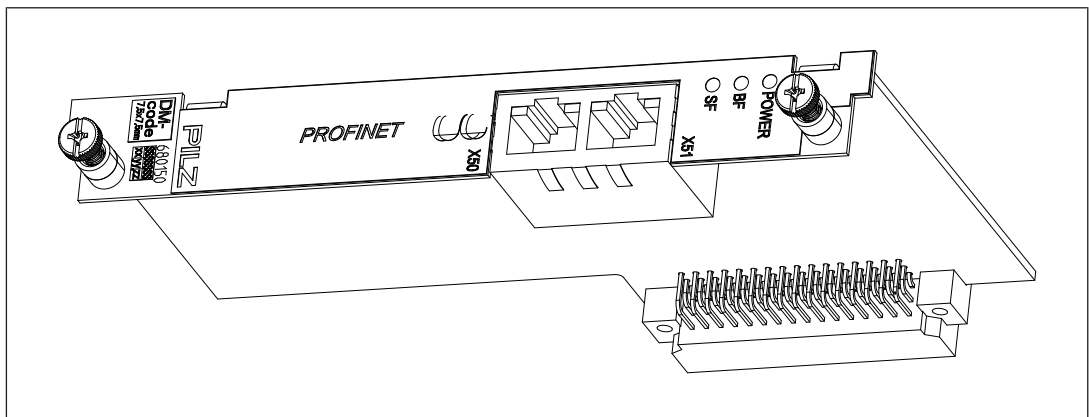

Fig.: PROFINET expansion card

3 Safety

3.1 Intended use

The PROFINET expansion card is used exclusively to connect the servo amplifier to a PROFINET controller. The servo amplifiers are installed as components in electrical apparatus or machinery and can only be commissioned as integrated plant components.

The following is deemed improper use

- ▶ Any component, technical or electrical modification to the servo amplifier.
- ▶ Use of the servo amplifier outside the areas described in this manual.
- ▶ Use of the servo amplifier outside the documented technical details (see chapter entitled "Technical Details")

Intended use includes making the installation and wiring EMC-compliant.

3.1.1 Hazard analysis

The machine manufacturer must produce a hazard analysis for the machine. He must take appropriate measures to ensure that unexpected movements do not lead to hazardous situations for either people or equipment.

3.1.2 Electrical data

Please note the electrical requirements stated in the chapters entitled "Technical Details", "Wiring" and "Function Description".

3.2 Safety during operation



INFORMATION

Please ensure you refer to the safety guidelines contained in the operating manuals for the respective servo amplifiers.

3.3 Safety regulations

3.3.1 Additional documents that apply

Please read and take note of the following documents:

- ▶ The servo amplifier PM Ctendo DD5 is described in the "Operating Manual PM Ctendo DD5".
- ▶ The servo amplifier PM Cprotego D is described in the "Operating Manual PM Cprotego D".
- ▶ Details of how to set the parameters for the servo amplifier are described in the online help for the commissioning software "PASmotion".

You will need to be conversant with the information in these documents in order to fully understand this manual.

**INFORMATION**

When the PROFINET expansion card is used in a PMCprotego D / PMCtendo DD5, the approvals of the relevant servo amplifier shall apply (see Technical Details in the operating manual of the servo amplifiers).

3.3.2 Use of qualified personnel

The products may only be assembled, installed, programmed, commissioned, operated, maintained and decommissioned by competent persons.

A competent person is someone who, because of their training, experience and current professional activity, has the specialist knowledge required to test, assess and operate the work equipment, devices, systems, plant and machinery in accordance with the general standards and guidelines for safety technology.

It is the company's responsibility only to employ personnel who:

- ▶ Are familiar with the basic regulations concerning health and safety / accident prevention
- ▶ Have read and understood the information provided in this description under "Safety"
- ▶ And have a good knowledge of the generic and specialist standards applicable to the specific application.

3.3.3 Warranty and liability

All claims to warranty and liability will be rendered invalid if

- ▶ The product was used contrary to the purpose for which it is intended
- ▶ Damage can be attributed to not having followed the guidelines in the manual
- ▶ Operating personnel are not suitably qualified
- ▶ Any type of modification has been made (e.g. exchanging components on the PCB boards, soldering work etc.).

3.3.4 Disposal

- ▶ When decommissioning, please comply with local regulations regarding the disposal of electronic devices (e.g. Electrical and Electronic Equipment Act).

4 Function description

4.1 Front view

The PROFINET expansion card provides a PROFINET interface for the servo amplifier PM-Cprotego D / PMctendo DD5.

The expansion card has a dual RJ45 PROFINET interface.

PROFINET networks of conformance class A/B are supported in accordance with IEC 61158 and IEC 61784.

The servo amplifier supplies the voltage to the expansion card.

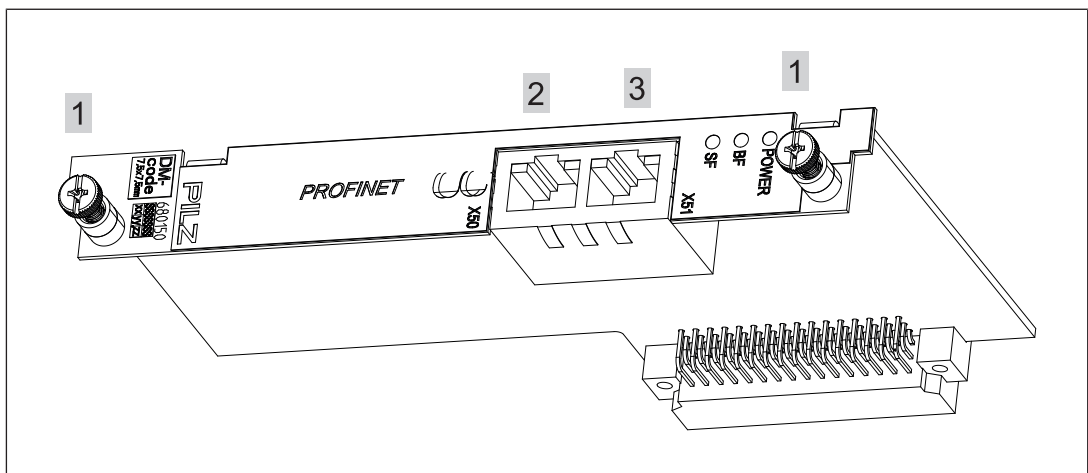

Fig.: PROFINET expansion card

Legende

- [1] Screw for attachment to the servo amplifier
- [2] PROFINET interface X50, P1
- [3] PROFINET interface X51, P2

LED indicator, front

POWER LED	Colour	Meaning	Further information
●	green	No supply voltage	
☀	green	Supply voltage is present	

SF LED	Colour	Meaning	Further information
●	red	No error	
☀	red	System error	
☾	red 2 Hz, 3 sec	DCP signal service is initiated via the bus	

BF LED	Col-our	Meaning	Further information
●	red	No error	
☀	red	Bus error	No configuration, physical connection is slow or non-existent
◐	red 2 Hz, 3 sec.	No data is being exchanged	

LED indicator, RJ45

LINK LED	Col-our	Meaning	Further information
●	green	No connection to Ethernet	
☀	green	Connection to Ethernet	

RX/TX LED	Col-our	Meaning	Further information
◐	yellow	Sends / receives Ethernet frames	

Legend

- ☀ LED on
- ◐ LED flashes
- LED off

4.2

Device master file

**INFORMATION**

The GSDML file is available on the Internet at www.pilz.de.

4.3 Interface assignment

PROFINET expansion card interfaces X50 P1, X51 P2

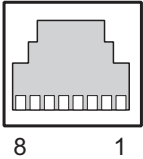
RJ45 socket 8-pin	PIN	Standard
	1	TD+ (Transmit+)
	2	TD- (Transmit-)
	3	RD+ (Receive+)
	4	n.c.
	5	n.c.
	6	RD- (Receive-)
	7	n.c.
	8	n.c.

n.c.: Not connected

4.4 Connection examples

4.4.1 Connection example PROFINET RT

Connection example in the RT network

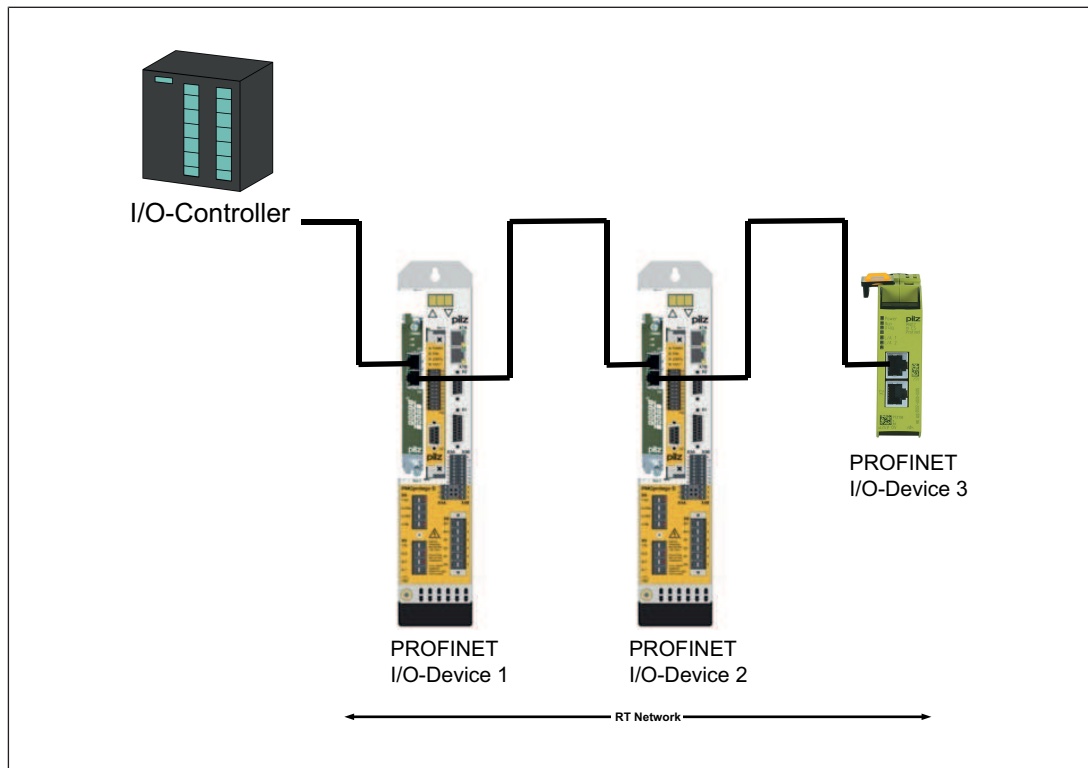

Fig.: Connection example PROFINET RT

4.4.2 Connection example PROFINET IRT / RT

Connection example in the IRT network / RT network

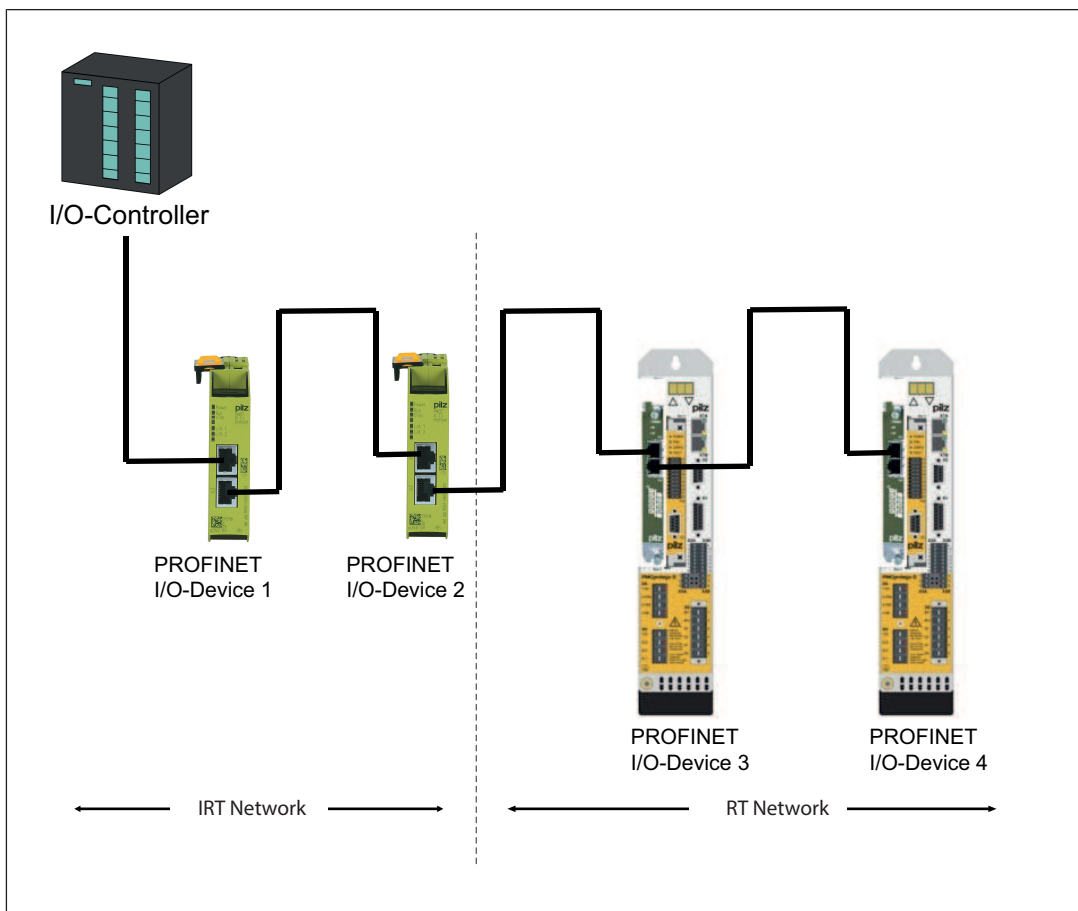

Fig.: Connection example PROFINET IRT / RT

4.4.3 Connection example IRT <Switch> RT

Connection example IRT network – Switch – RT network

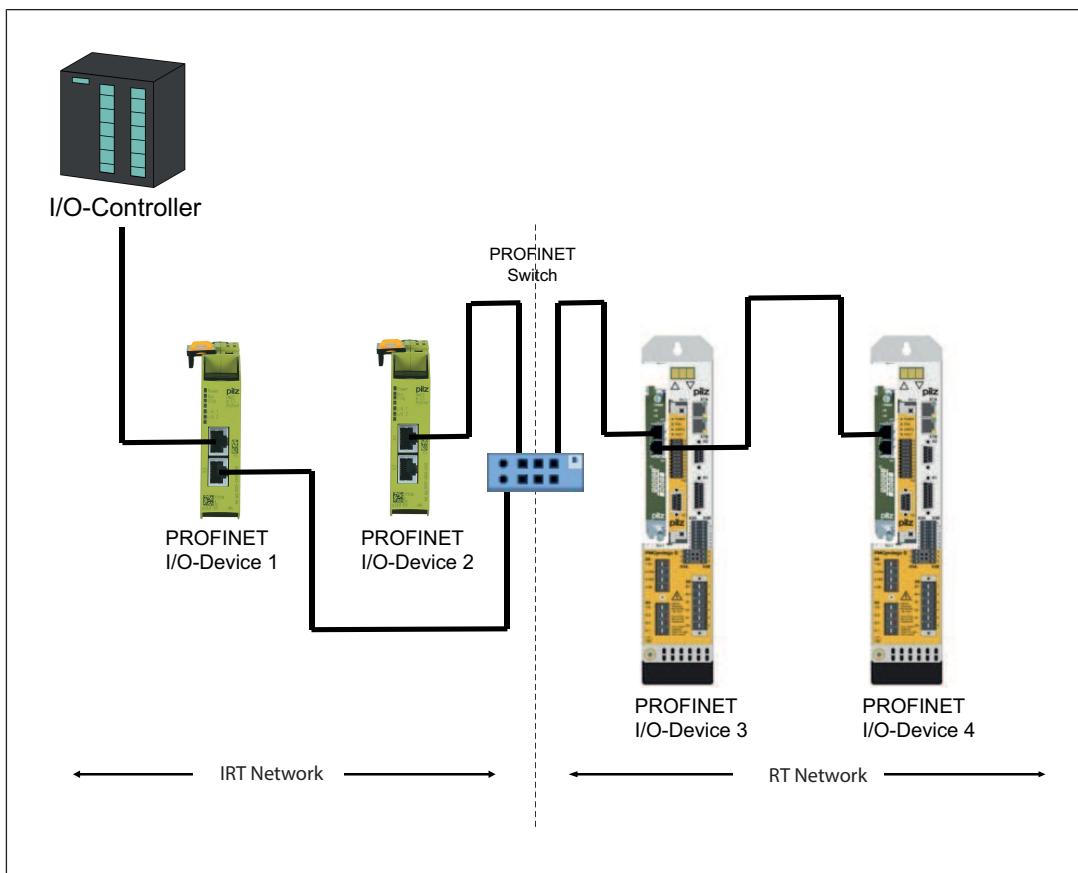

Fig.: Connection example PROFINET IRT <Switch> RT

5 Assembly



INFORMATION

Please note: Do not twist the expansion card as you insert it or damage any components.

5.1 Installing the expansion card in the servo amplifier PMCtendo DD5

The top of the servo amplifier contains a slot for holding expansion cards.





	<p>Lever the cover off using a suitable screwdriver.</p> <p>Make sure that no foreign bodies fall into the open slot.</p>
	<p>Remove the small cover grille.</p> <p>Press the small cover grille back on to the small part of the slot.</p>
	<p>Push the expansion card into the guide rails.</p> <p>Do not twist the expansion card as you insert it!</p> <p>The expansion card is inserted correctly when the front rests on the servo amplifier's mounting lugs.</p> <p>Fix the screws in place.</p>

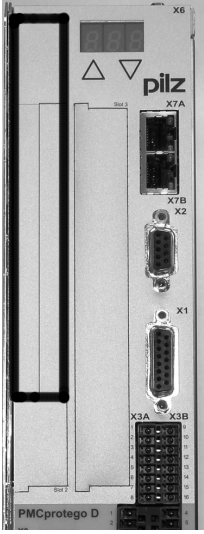

Fig.: PROFINET expansion card installed in PMctendo DD5

5.2 Installing the expansion card in the servo amplifier PMCprotego

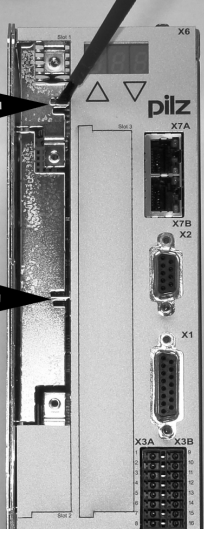
The PROFINET expansion card is installed in slot 1

		
<p>Set the boundary for slot 1</p>	<p>Remove the film (perforation)</p>	<p>Tear off the film as far as the marker</p>
		
<p>Break the top and bottom link</p>	<p>Break out the top and bottom plate</p>	<p>Insert the expansion card</p>

		
<p>Tighten up the screws</p>		



Fig.: PROFINET expansion card installed in PMCprotego D

6 Wiring

6.1 Connection technology



INFORMATION

The PROFIBUS User Organisation PNO describes the cable selection, cable routing, shielding, bus connectors, bus termination and runtimes.

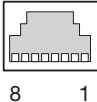
Connector X50, X51	Pin	Colour	Standard
	1	Yellow	TD+ (Transmit+)
	2	orange	TD- (Transmit-)
	3	white	RD+ (Receive+)
	4		n.c.
	5		n.c.
	6	blue	RD- (Receive-)
	7		n.c.
	8		n.c.
n.c.: Not connected			

Connector pin assignment

Please note the following when making the PROFINET connection

- ▶ The following minimum requirements of the connection cable and connector must be met:
 - Only use standard industrial Ethernet cable and connectors.
 - Only use double-shielded twisted pair cable and shielded RJ45 connectors (industrial connectors).
 - 100BaseTX cable in accordance with the Ethernet standard (min. Category 5)
- ▶ Measures to protect against interference:

Ensure the requirements for the industrial use of PROFINET are met, as stated in the Installation Manual published by the User Organisation.

7 Commissioning

7.1 Guide to commissioning

	<p>CAUTION!</p> <p>Less serious or minor injury, material damage</p> <p>The servo amplifier may only be commissioned by qualified personnel with sound knowledge of control and drive technology.</p>
---	--

<p>Check assembly / installation</p>	<p>Check that all the safety guidelines in this manual and in the operating manual for the servo amplifier are respected and implemented.</p>
--------------------------------------	---

<p>Connect PC, start commissioning software</p>	<p>Use the commissioning software to set the parameters for the servo amplifier.</p>
---	--

<p>DANGER, WARNING</p>	<p>Ensure that no hazard can result for personnel or machinery, even if the drive should move unintentionally.</p>
-------------------------------	---

<p>Commissioning the basic function</p>	<p>Commission the basic functions of the servo amplifier and optimise the current and speed controller. This part of the commissioning process is described in more detail in the commissioning software's online help.</p>
---	---

<p>Save parameters</p>	<p>Once the parameters have been optimised they should be saved in the servo amplifier.</p>
------------------------	---

Check the bus connection	<p>Remove the enable signal (terminal X3) and switch off the power supply to the servo amplifier. The 24 VDC auxiliary voltage remains switched on.</p> <p>Check the installation of the PROFINET connection and the interface of the PROFINET Master.</p> <p>Check the PROFINET parameter settings and station configuration.</p> <p>Check the parameter settings for the PROFINET interface module.</p> <p>Check the user PLC program and the function block's parameter settings.</p>
--------------------------	--

7.2 Important configuration parameters

The following parameters configure the servo amplifier for **PROFINET**. They can be set using the commissioning software (PASmotion) for the servo amplifier.

Connection monitoring

EXTWD (PNU1658) reaction monitoring time (Watch Dog)
(PASmotion: PN-PZD-Timeout)

Behaviour of the outputs when IOPS = Bad

Parameters	Value	Description
Slot	1	PROFINET IO Slot
IOPS Input Status Amplifier	0x00	Bad → Input data invalid → Input data become = 0x00
	0x80	Good → Input data valid → Input data

Behaviour of the outputs when connection is lost

To prevent the drive from responding in an unwanted way when the PROFINET connection is interrupted (an open circuit, for example), you should monitor the arrival of cyclical process data.

The parameter EXTWD can be used to define the reaction monitoring time (Watchdog) for the fieldbus/slot communication.

Monitoring is only active if the parameter EXTWD has a value greater than zero (EXTWD = 0, monitoring switched off) and the output stage is enabled.

If the set time has elapsed and the watchdog timer has not been retriggered by the arrival of a telegram, warning "n04" reaction monitoring is generated and the drive is stopped.

The amplifier remains ready for operation and the output stage is enabled.

This warning "n04" must be cleared (CLRFAULT function or INxMODE = 14) before a new motion command (setpoint value) is accepted.

When you activate the timeout (EXTWD), the amplifier behaves as follows in the case of an error:

The motor then does not start up automatically. A zero telegram has to be sent again, or PROFINET has to be re-initialised.

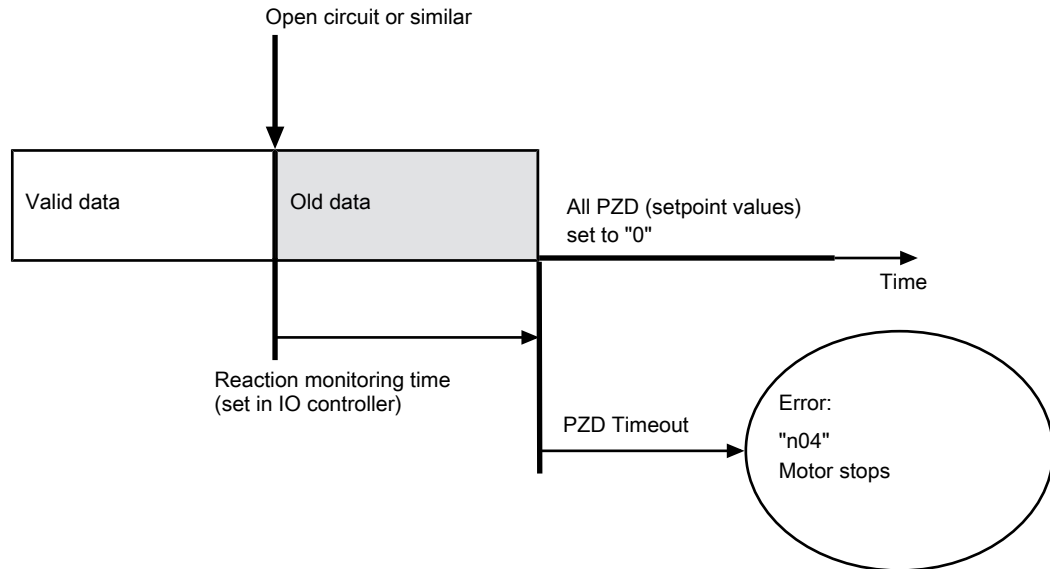

DANGER!

Risk of injury if the motor starts up

Depending on the application, serious injury including death may result.

When the reaction monitoring time parameter (Watchdog) EXTWD is set to "0", the motor stops when connection to PROFINET is lost. The motor continues to run after the connection has been established again.

Set the parameter EXTWD to greater than "0".

Behaviour of the outputs after power on

Operating mode -126 (safe state) is always set when the servo amplifier is switched on. The outputs are also set to "0".

AENA (PNU 1606)

This can be used to define the state of the software enable when the servo amplifier is switched on. The software enable allows an external control system to enable or disable the output stage through the software. Where devices operate with an analogue setpoint value (OPMODE = 1,3), the software enable is set automatically when the servo amplifier is switched on, so that these devices are ready for operation immediately (provided the hardware enable is present). With all other devices, the software enable is set to the value of AENA when switching on. The AENA variable also has a function when resetting the servo

amplifier after an error (via digital input 1 or with the ASCII command CLRFAULT). Where errors can be reset through the software, once the error has been cleared, the software enable is set to the status of AENA. In this way, the behaviour of the amplifier during a software reset is similar to that of the switch-on behaviour.

INPT, INPT0 (PNU 1904)

The INPT0 command defines a delay time for the in-position message. When a motion task is started, the in-position message is cleared and monitoring of the in-position window is activated once the set time has elapsed. This function is particularly important for positioning procedures within the in-position window. In this case it is guaranteed that the in-position message is cleared for a defined time.

PNSTNAME

The PNSTNAME command is used to define the amplifier's fieldbus device name. This name must be newly assigned for each individual amplifier. (It replaces the known bus address from PROFIBUS DP.)



INFORMATION

Each device name in the PROFINET network may be assigned once only.

Please note the following when assigning the device name:

- ▶ The device name is limited to 127 characters in total.
- ▶ A name component within the device name may be a max. 63 characters in length. (One character string between two points.)
- ▶ Permitted characters: Letters "a" ... "z", digits "0" ... "9", hyphen or dot.
- ▶ Upper case characters may not be used in the device name.
- ▶ The device name may not start or end with the following characters: "-" and "."
- ▶ The device name may not start with digits.
- ▶ The device name may not have the format n.n.n. (n = 0 ... 999)
- ▶ The device name may not start with the character string "port-xyz-" (xyz = 0 ... 9)
- ▶ Device names are assigned to the PROFINET IO devices in the commissioning phase.

Assigning the number of the PROFINET device name at the servo amplifier

The **number** of the PROFINET device name can also be assigned via the arrow keys at the servo amplifier. (e.g. pilz-inverter-**10**)

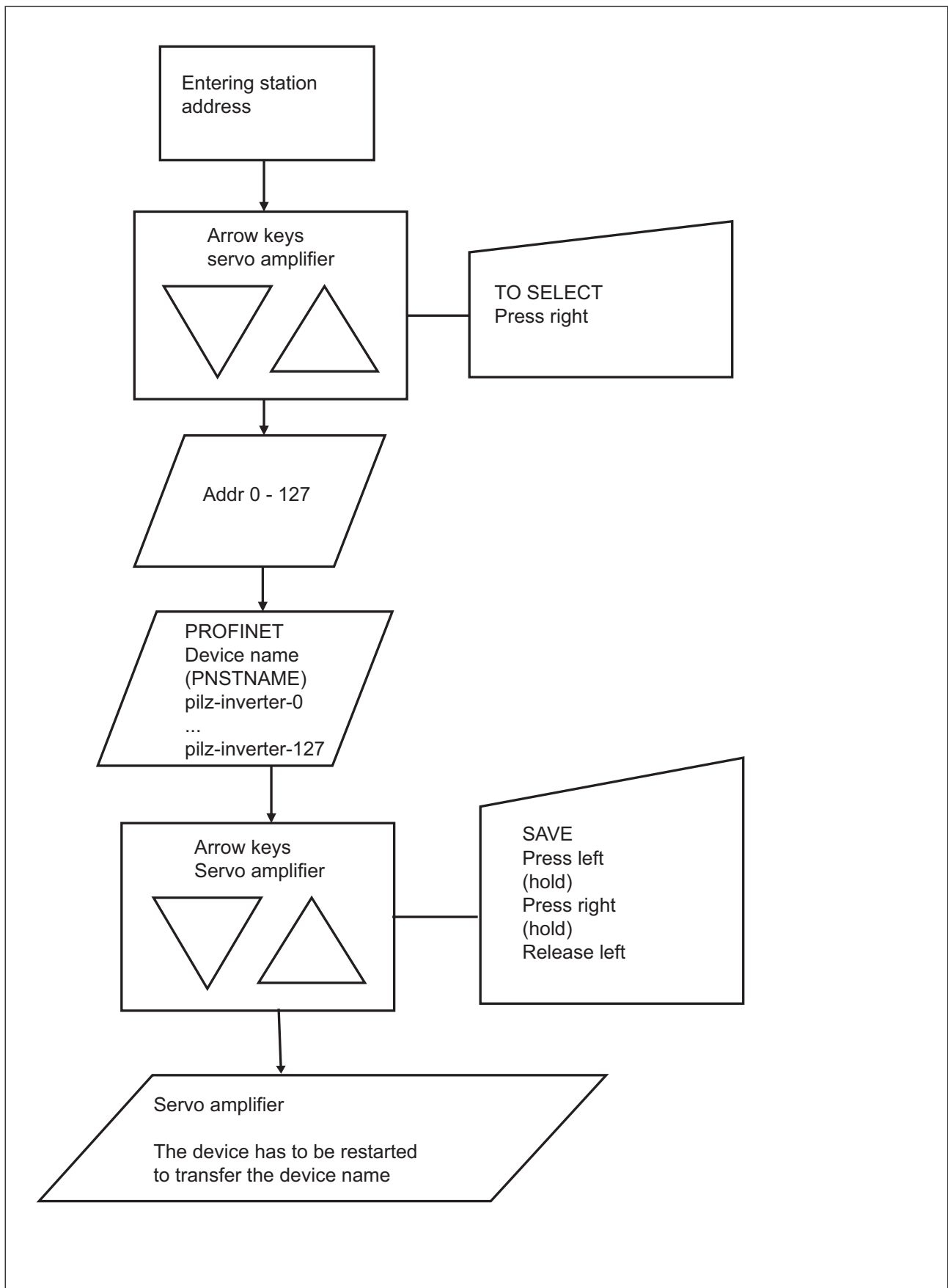

Fig.: Flowchart Assigning the number of the PROFINET device name at the servo amplifier

**INFORMATION**

The **"RSTVAR" command** (parameters are set to default values) is used to reset the PROFINET device name to the set ADDR "pilz-inverter-0 bis pilz-inverter-127". When no "ADDR" is set at the amplifier, the amplifier is given the device name "pilz-inverter-0".

PNIP

The PNIP command is used to define the amplifier's fieldbus IP address. The assignment is normally made automatically through the controller (S7, TIA). However, in some cases the PROFINET IO devices may also be assigned a manual IP address. This is stored in the amplifier in remanent memory.

**INFORMATION**

The network mask should be stated in the correct format.

PNGWAY

The PNGWAY command is used to define the amplifier's fieldbus gateway. The assignment is normally made automatically through the controller (S7, TIA). However, in some cases the PROFINET IO devices may also be assigned a manual gateway. This is stored in the amplifier in remanent memory.

**INFORMATION**

The gateway address should be stated in the correct format.

PNMS

The ASCII command PNMS can be used to set the PROFINET cycle time on the amplifier. It is possible to set the bus cycle time to 1 ms or 4 ms. The default value of PNMS is set to 4 ms.

**INFORMATION**

Under the following conditions the cycle time is set to 4 ms automatically:
In the servo amplifier a safety card with the Encoder types (FBTYPE 12, 16, 17, 27) is built in, and the bus cycle time has been changed from 4 ms to 1 ms.

7.3 Commissioning software PASmotion

7.3.1 PROFINET window

The window only appears if the PROFINET hardware is installed in the servo amplifier. It displays PROFINET-specific parameters, the bus status and the data words in the send and receive direction, viewed from the bus master.

This page is helpful when troubleshooting and when commissioning the bus communication.

7.3.2 PASmotion PROFINET "Settings" tab



Fig.: PASmotion settings

PN device name [current]:

Shows the device name currently used by the amplifier. A new device name may be entered in this field and assigned to the amplifier. Please note that the new device name will not be active until the amplifier is restarted.

PN device name:

PN-PZD timeout:

This parameter corresponds to the EXTWD command, see [Important configuration parameters](#) [22]

Manual configuration of IP data:	The checkbox is unticked as the default setting. The settings for IP address, network mask and gateway can be shown by ticking the box.
PN-IP address [current]:	Shows the value currently set for the IP address. This value is normally assigned by the controller (S7, TIA).
PN-IP address	A new, manually assigned IP address can be assigned to the amplifier in this field. Please note that the new IP address will not be active until it has been saved and the amplifier restarted.
PN network mask [current]:	Shows the value currently set for the network mask. This value is normally assigned by the controller (S7, TIA).
PN network mask:	A new, manually assigned network mask can be assigned to the amplifier in this field. Please note that the new network mask will not be active until it has been saved and the amplifier restarted.
PN gateway [current]:	Shows the value currently set for the gateway. This value is normally assigned by the controller (S7, TIA).
PN gateway:	A new, manually assigned gateway address can be assigned to the amplifier in this field. Please note that the new gateway address will not be active until it has been saved and the amplifier restarted.
PROFINET diagnostic information:	Shows the current status of bus communication. Data can only be transferred via the PROFINET bus when the Communication OK message appears in green.
Device information:	Shows the serial number, hardware version and firmware version of the PROFINET expansion card, as assigned by Pilz.
Input:	The last bus object received by the master.
Output:	The last bus object transmitted by the master.

**INFORMATION**

Data for input/output is only transmitted if reaction monitoring for the servo amplifier has been activated in the hardware configuration on the master.

7.3.3 PASmotion PROFINET "Device Control" tab

This window shows the bit states of the control word (STW) and status word (ZSW). The device state that results from the status word is visualised in the state machine. The current state is shown in black, all other states in grey. The previous state is also visualised by highlighting the number of the corresponding arrow.

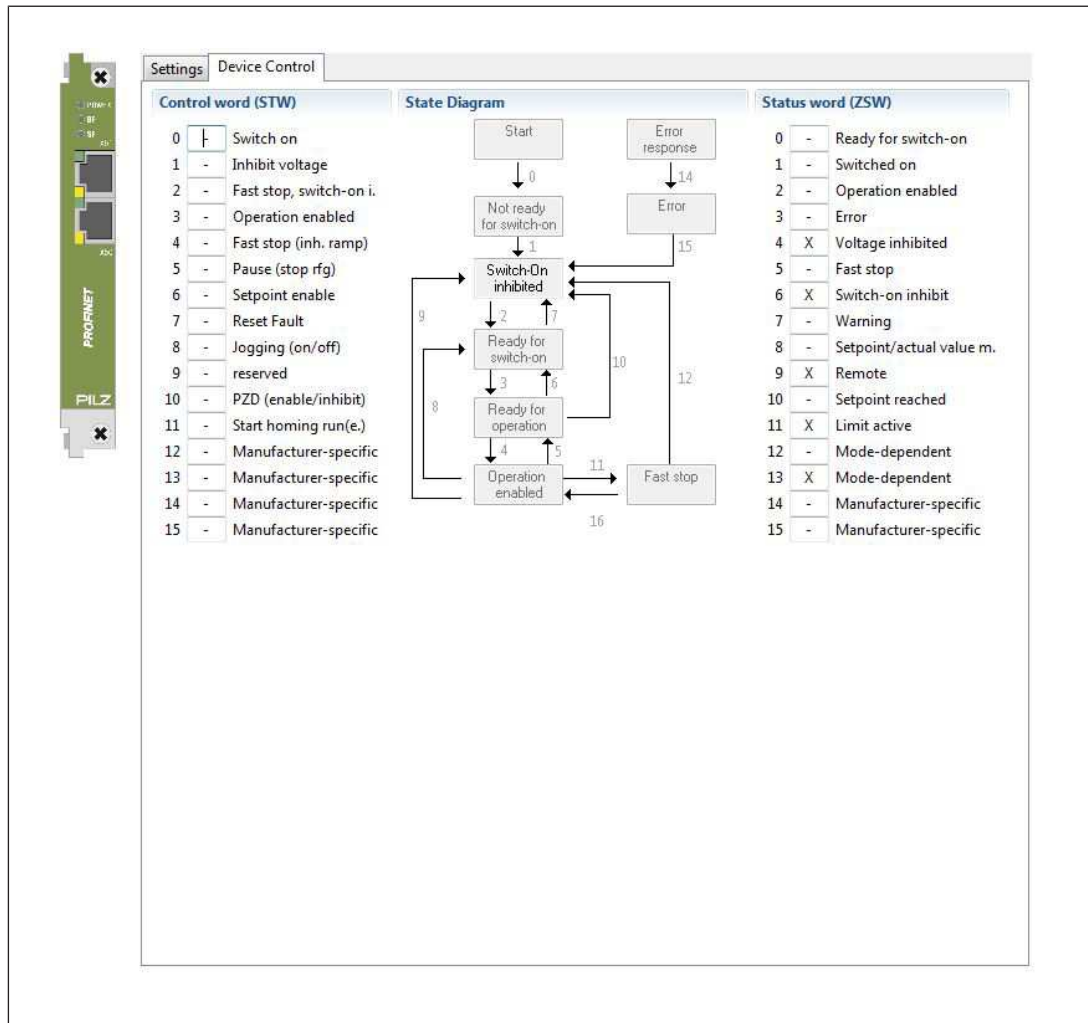

Fig.: PASmotion PROFINET device control

7.4 Setting the device name on PROFINET

Setting options:

- ▶ Using the commissioning software PASmotion (see online help)
- ▶ Via the serial interface, with the sequence of ASCII commands
-> PILZ-INVERTER-PNSTNAME > SAVE >COLDSTART

8 Device profile

8.1 General

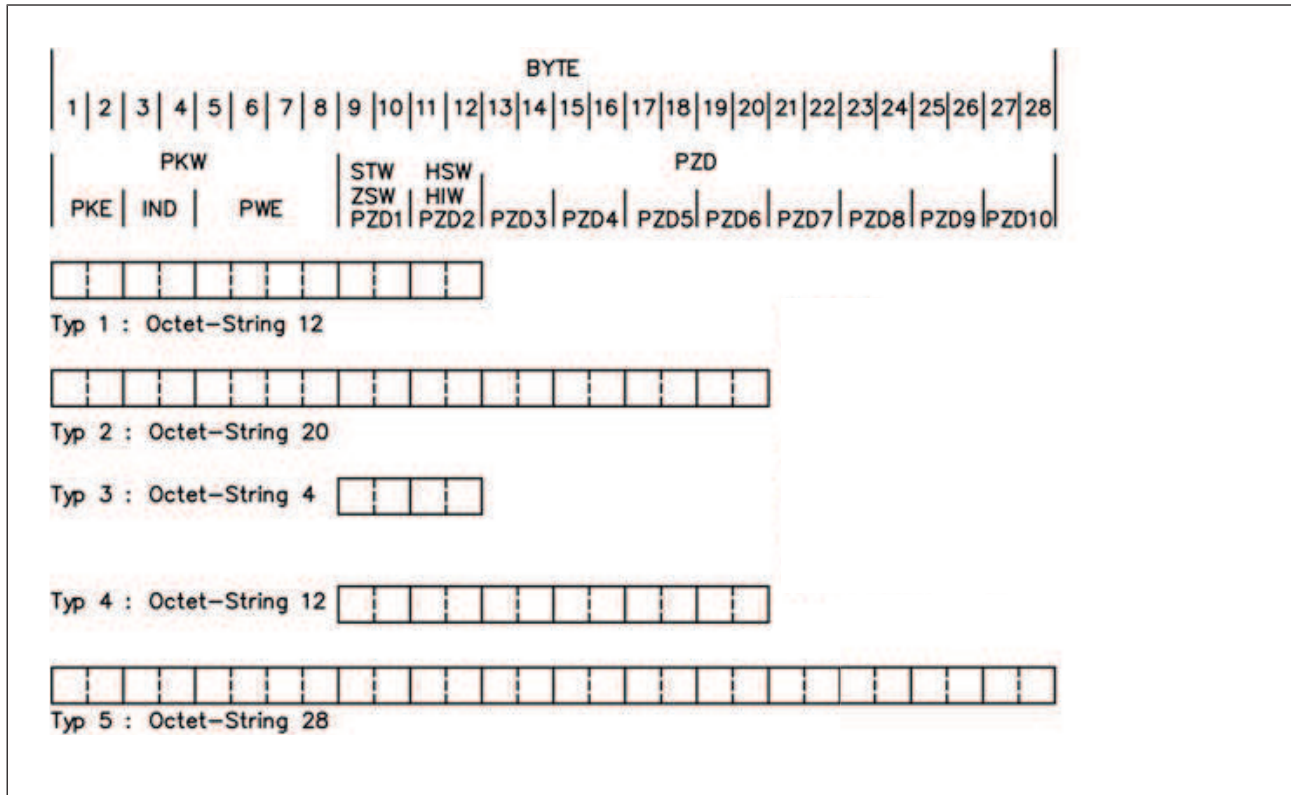

Fig.: Parameter process data objects

Legende

[PKW]	Parameter identifier value
[PZD]	Process data
[PKE]	Parameter identifier (1st & 2nd octet)
[IND]	Subindex (3rd octet), 4th octet reserved
[PWE]	Parameter value (5th to 8th octet)
[STW]	Control word
[ZSW]	Status word
[HSW]	Main setpoint value
[HIW]	Main actual value

A device profile based on the PROFIDRIVE profile is implemented. The PROFIDRIVE profile uses parameter process data objects (PPO). Profile number 3, Version 2 is used.

The servo amplifier only uses the PPO type 2 with 4 words in the PKW section and 6 words in the PZD section. The PKW section is primarily used to transfer servo amplifier parameters; the PZD section is primarily used to manage motion functions.

The telegram can be divided into two sections / data channels:

- ▶ PKW section (4 words)
- ▶ PZD section (6 words)

The PKW data channel is also called the service channel. The service channel only uses confirmed communication services and is used on the servo amplifier as a parameter channel.

The PKW channel does not have real-time capability.

The PZD data channel is also called the process data channel. The process data channel uses unconfirmed communication services. The response of the servo amplifier to an unconfirmed service can only be seen from the device reaction. (status word, actual values).

The PZD channel has real-time capability.

8.2 Parameter channel

8.2.1 Parameter identifier PKE

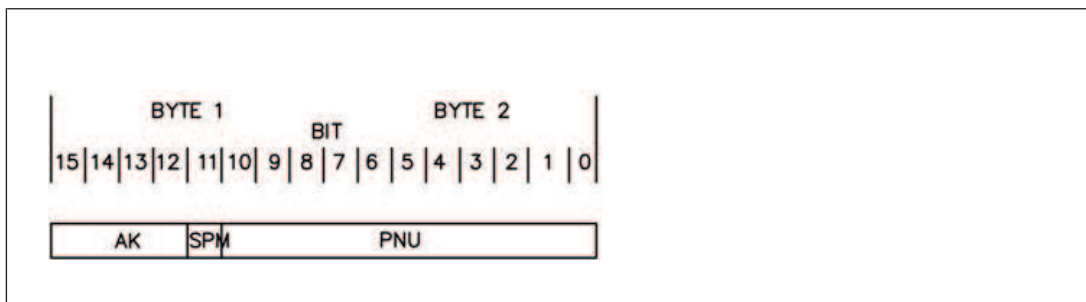

Fig.: Parameter identifier PKE

Legende

[AK]	Order / response identifier
[SPM]	Toggle bit for spontaneous message (currently not implemented)
[PNU]	Parameter number

Lines in the table that are marked in bold are valid for servo amplifiers.

Master → Slave		Slave → Master	
Task ID	Function	Response identifier positive	Response identifier negative
0	No task	0	0
1	Request parameter value	1.2	7
2	Change parameter value [W]	1	7/8

3	Change parameter value [DW]	2	7/8
4	Request description element	3	7
5	Change description element	3	7/8
6	Request parameter value [A]	4.5	7
7	Change parameter value [A/W]	4	7/8
8	Change parameter value	5	7/8
9	Request number of array elements	6	7
10 -15	Reserved		

8.2.1.1 Meaning of response identifiers

Lines in the table that are marked in bold are valid for servo amplifiers.

Response identifier	Meaning
0	No task
1	Transmit parameter value
2	Transmit parameter value
3	Transmit description element
4	Transmit parameter value
5	Transmit parameter value
6	Transmit number of array elements
7	Task cannot be executed (with error number)
8	No control authority for PKW interface
9	Spontaneous message [W]
10	Spontaneous message [DW]
11	Spontaneous message [A/W]
12	Spontaneous message [A/DW]

Legend

[A]

Array

[DW]

Double word

[W]

Word

8.2.1.2 Profile-specific error numbers with response identifier 7

Error number	Description
0	Invalid PNU
1	Parameter value cannot be changed
2	Lower or upper value limit exceeded
3	Faulty index
4	No array
5	Incorrect data type
6	Setting not permitted (can only be reset)
7	Description element cannot be changed
8	PPO-Write requested in IR not available
9	Description data not available
10	Access group
11	No control authority
12	Keyword missing
13	Text in cyclical traffic unreadable
14	Name in cyclical traffic unreadable
15	No text array available
16	PPO-Write is missing
17	Cannot switch operating mode when STW Bit 10 = 1 (PZD enable)
18	Other errors
19 -100	Reserved
101	Faulty task identifier
102	Software error (command table)
103	Only possible in disabled state
104	Only possible in enabled state
105	BCC error in the EEPROM data
106	Only possible after motion task is stopped
107	Incorrect value [16.20]
108	Incorrect parameter (OCOPY x [- y] z)
109	Incorrect motion block number (0.1 ... 180.192...255)
110	Incorrect parameter (PTEACH x [y])
111	EEPROM write error
112	Incorrect value
113	BCC error in motion block
114	Only read access or write access possible

Error number	Description
115	Not possible due to operating state (e.g. output stage enabled)
>115	Reserved

8.2.2 Index IND

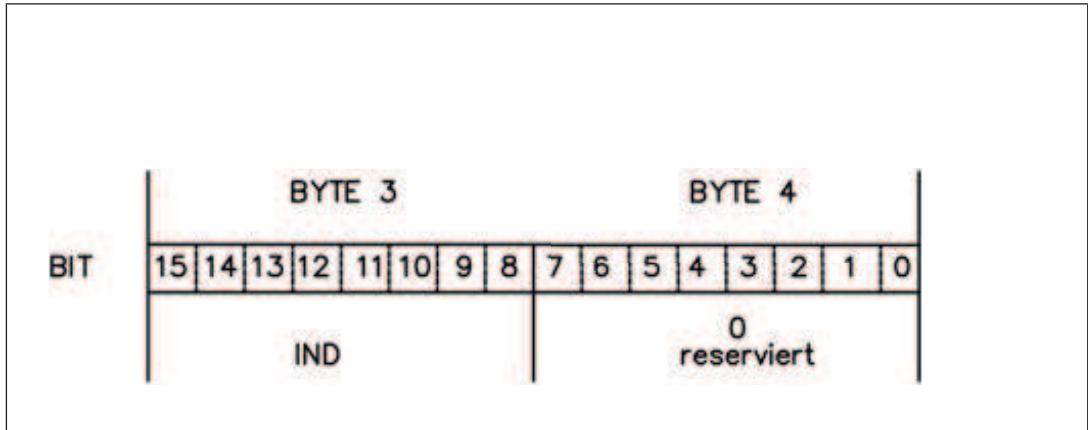

Fig.: Index IND



INFORMATION

Reading and writing PNUs > 1600:

Use the index in accordance with the description [Manufacturer-specific object channel \(from PNU 1600\)](#) [52].

8.2.3 Parameter value PWE

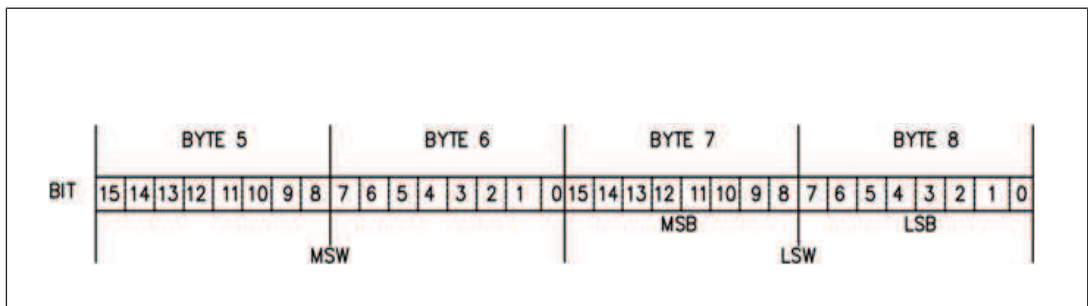



Fig.: Parameter value PWE

The data for the PNU variable can be found in the PWE and is right-justified:

4-Byte data (double word)	PWE 5 – 8 (PWE 8 LSB)
---------------------------	-----------------------

Commands are transmitted with task identifier 3. If a command cannot be executed, the error is signalled with response identifier AK = 7 and an error number is issued. For details of error numbers see [Profile-specific error numbers with response identifier 7](#)  33].

8.3 Process data channel

Cyclical data is exchanged via the process data section of the 20-Byte telegram. Each cycle triggers an interrupt in the servo amplifier; as a result, new process data is exchanged and processed. The meaning of this process data depends on the set operating mode. The operating mode is set via a PROFINET parameter (PNU 930, see section entitled [PNU 930: Selector switch for operating modes](#)  42]).

In all operating modes, data word 1 of the process data (PZD1) is used for device control in the controller -> servo amplifier direction; in the servo amplifier -> controller direction it has the function of a status indicator for the drive.

The meaning of the process data PZD2 – PZD6 changes depending on the set operating mode, see [Operating modes \(Opmodes\)](#)  63].



INFORMATION

Operating mode -126 (safe state) is always set when the servo amplifier is switched on. Bit 10 of the control word STW must always be set to 0 before switching operating modes. The new operating mode does not become active until control word bit 10 is set to 1. (see [PNU 930: Selector switch for operating modes](#)  42]).

9 Parameter channel



The digital servo amplifiers must be adapted to the machine's conditions. Parameters for the servo amplifiers are set via the commissioning software or via PROFINET.

9.1 Writing/reading an amplifier parameter

Write (AK = 3) or read (AK = 1) amplifier parameter

Writes or reads an amplifier parameter, which is identified by the parameter number (PNU), to the servo amplifier's volatile memory. The parameters stored in the servo amplifier can be transferred to non-volatile memory using the command "Save in non-volatile memory" (PNU 971).

Telegram structure:

	Request	Response
PKE/AK	1 (read) / 3 (write)	2 (ok) / 7 (error)
PKE/PNU	See Composition of parameter numbers [ 36]	As transmitted
PWE	When AK = 3, see Composition of parameter numbers [ 36] for data type When AK = 1, data type is insignificant	When AK = 3, PWE of request is mirrored When AK = 1, see Composition of parameter numbers [ 36] for data type

9.2 Composition of parameter numbers

The table on the following pages lists the most important amplifier parameter numbers in numerical order, with a short description. The parameter numbers in the range 900 – 999 are PROFINET-specific parameters. Parameter numbers > 999 are manufacturer-specific.

For a better understanding of what the parameters mean, you can look up the ASCII commands shown in the "ASCII command" column in the online help for the commissioning software. You'll find a description of all the parameters in the respective ASCII command list.



INFORMATION

Parameter numbers over 1600 use the object channel. For details see [Manufacturer-specific object channel \(from PNU 1600\)](#) [ 52]

9.2.1 List of selected parameter numbers

PNU	Data type	Access	Brief description	ASCII command
Profile parameters				
904	UINT32	ro	Number of the supported PPO-Write, always 2	
911	UINT32	ro	Number of the supported PPO-Read, always 2	
930	UINT32	r/w	Selector switch for operating mode	
965	Octet-String2	ro	Number of PROFIDRIVE profile (0302H)	
970	UINT32	wo	Load default parameter set	RSTVAR
971	UINT32	wo	Save parameters in non-volatile memory	SAVE
Manufacturer-specific parameters				
General parameters				
1000	Visible String4	ro	Device ID	
1001	UINT32	ro	Manufacturer-specific error register	ERRCODE
1002	UINT32	ro	Manufacturer-specific status register	
Speed controller parameters				
1672	UINT32	r/w	Kp – gain factor of speed controller	GV
1677	UINT32	r/w	Tn – reset time of speed controller	GVTN
1601	UINT32	r/w	Setpoint value ramp+, speed controller	ACC
1634	UINT32	r/w	Setpoint value ramp-, speed controller	DEC
1637	UINT32	r/w	Emergency ramp, speed controller	DECSTOP

PNU	Data type	Access	Brief description	ASCII command
1890 1891	UINT32	r/w	Maximum speed	VLIM VLIMN
1895	UINT32	r/w	Overspeed	VOSPD
1642	UINT32	r/w	Count direction	DIR
Position control parameters				
1894	UINT32	r/w	Multiplier for jogging/ref. speeds	VMUL
1807	UINT32	r/w	Axis type	POSCNFG
1798	INTEGER32	r/w	In-Position window	PEINPOS
1799	INTEGER32	r/w	Position error window	PEMAX
1860	INTEGER32	r/w	Position register 1	SWE1
1862	INTEGER32	r/w	Position register 2	SWE2
1803	UINT32	r/w	Denominator resolution	PGEARO
1802	UINT32	r/w	Counter resolution	PGEARI
1814	UINT32	r/w	Minimum acceleration/braking time	PTMIN
1669	UINT32	r/w	Feed forward factor for position controller	GPFFV
1666	UINT32	r/w	KV – factor for position controller	GP
1816	UINT32	r/w	Maximum speed for positioning mode	PVMAX
1856	UINT32	r/w	Configuration variable for software switch	SWCNFG
Positioning data for position controller mode				
1790	INTEGER32	r/w	Position	O_P
1791	INTEGER16	r/w	Speed	O_V
1785	UINT32	r/w	Motion task type	O_C
1783	INTEGER16	r/w	Start-up time (acceleration)	O_ACC
1786	INTEGER16	r/w	Braking time (delay)	O_DEC

PNU	Data type	Access	Brief description	ASCII command
1788	UINT32	r/w	Number of next motion task	O_FN
1789	UINT32	r/w	Start delay for next motion task	O_FT
1310	2 * UINT16	wo	Copying a motion task	OCOPY
Setup mode, position				
1773	UINT32	r/w	Reference run type	NREF
1644	UINT32	r/w	Reference run direction	DREF
1602	UINT32	r/w	Acceleration ramp (jogging/referencing)	ACCR
1636	UINT32	r/w	Braking Ramp	DECR
1831	UINT32	r/w	Reference offset	ROFFS
1896	UINT32	ro	Reference run speed	VREF
1889	UINT32	r/w	Jog speed	VJOG
Actual values				
1810	INTEGER32	ro	Actual position 20 bits / revolution	PRD
1800	INTEGER32	ro	SI – Actual position value	PFB
1815	INTEGER32	ro	SI – Actual speed value	PV
1797	INTEGER32	ro	SI - Position error	PE
1688	INTEGER32	ro	Effective current	I
1880	INTEGER32	ro	SI - Actual speed value	V
1873	INTEGER32	ro	Heat sink temperature	TEMPH
1872	INTEGER32	ro	Internal temperature	TEMPE
1882	INTEGER32	ro	Intermediate circuit voltage	VBUS
1792	INTEGER32	ro	Braking power (previously ballast power)	PBAL
1764	INTEGER32	ro	MI2T - load	MI2T
1876	INTEGER32	ro	Operating time	TRUN

PNU	Data type	Access	Brief description	ASCII command
Digital I/O configuration				
1698	UINT32	r/w	Function of digital input 1	IN1MODE
1701	UINT32	r/w	Function of digital input 2	IN2MODE
1704	UINT32	r/w	Function of digital input 3	IN3MODE
1707	UINT32	r/w	Function of digital input 4	IN4MODE
1699	INTEGER32	r/w	Auxiliary variable for digital input 1	IN1TRIG
1702	INTEGER32	r/w	Auxiliary variable for digital input 2	IN2TRIG
1705	INTEGER32	r/w	Auxiliary variable for digital input 3	IN3TRIG
1708	INTEGER32	r/w	Auxiliary variable for digital input 4	IN4TRIG
1775	INTEGER32	r/w	Function of digital output 1	O1MODE
1778	INTEGER32	r/w	Function of digital output 2	O2MODE
1776	UINT32	r/w	Auxiliary variable for digital output 1	O1TRIG
1779	UINT32	r/w	Auxiliary variable for digital output 2	O2TRIG
1852	UINT32	r/w	State of 4 digital inputs, enable, 2 digital outputs	STATIO
Analogue configuration				
1607	UINT32	r/w	Configuration of analogue input functions	ANCNFG
1611	UINT32	r/w	Offset voltage for analogue input 1	ANOFF1
1617	UINT32	r/w	Filter time constant for analogue input 1	AVZ1

PNU	Data type	Access	Brief description	ASCII command
1897	UINT32	r/w	Scaling factor for speed, analogue input 1	VSCALE1
1713	UINT32	r/w	Scaling factor for current, analogue input 1	ISCALE1
1612	UINT32	r/w	Offset voltage for analogue input 2	ANOFF2
1898	UINT32	r/w	Scaling factor for speed, analogue input 2	VSCALE2
1714	UINT32	r/w	Scaling factor for current, analogue input 2	ISCALE2
Motor parameters				
1735	UINT32	r/w	Brake configuration	MBRAKE
1753	UINT32	r/w	Motor number from motor database	MNUMBER
Status of expansion card PMCprotego S				
1712	UINT32	ro	General status	CSSTAT
1713	UINT32	ro	I/O status	CSIOSTAT
1714	UINT32	ro	Error status	CSERR
Manufacturer-specific object channel				
1600	See Manufacturer-specific object channel (from PNU 1600) [52] and description of the ASCII commands in the online help			

Abbreviations in the "Access" column

[wo]

"write only" access

[ro]

"read only" access

[r/w]

"Read/write" access

9.2.2 Profile parameters

9.2.2.1 PNU 970: Default parameter

With this parameter you can reject all the set parameters and load the manufacturer's default values.

9.2.2.2 PNU 971: Save parameters in non-volatile memory

With this parameter you can save all the parameter settings in non-volatile EEPROM memory. To do this, the parameter must have the value PWE = 1 when transferred.

9.2.2.3 PNU 930: Selector switch for operating modes

The "Selector switch for operating modes" is defined by the drive profile and maps the operating modes of the drive profile to the operating modes of the servo amplifier. The following table compares the operating modes:



INFORMATION

If process data is exchanged via PROFINET:

Select the operating modes of the drive profile with PNU 930.

Operating mode Drive profile	Operating mode Servo amplifier (ASCII command "OP- MODE")	Brief description
2	8	Positioning mode
1	0	Speed control, digital
0	-	Reserved
-1	1	Speed control, analogue set-point
-2	2	Torque control, digital set-point
-3	3	Torque control, analogue setpoint
-4	4	Position control, electronic gearing
-5	5	Position control, external trajectory
-6 to -15	-	Reserved
-16	-	ASCII channel for expanded parameter setting
-17 to -125	-	Reserved
-126	-	Default setting when device is switched on

The individual operating modes are described in [Operating modes \(Opmodes\)](#) [63]. An operating mode can only be changed in conjunction with the control word.

The operating mode must be changed in the following sequence:

▶ **Disable setpoints and process data**

Bit 10 in the control word is set to 0, so that the servo amplifier adopts no more setpoints and new control functions can be triggered. However, a new operating mode can be selected as a motion function is being executed. The control word is only disabled to the extent that the servo amplifier can always be switched to a safe state.

▶ **Select new operating mode with PNU 930**

With parameter 930, the new operating mode is selected via the parameter channel but is not yet adopted.

▶ **Set/receive setpoint and actual values**

Enter the corresponding setpoints in the process data's setpoint area. Note that the standardisation and data formats depend on the selected operating mode. The meaning of the actual values also changes. The user program must react accordingly.

▶ **Enable setpoints**

Bit 10 STW is set to 1. The setpoints are adopted and processed immediately. The new actual values with the appropriate standardisation and data format are issued.



CAUTION!

Motor drive starts up via the commissioning software, injuries, error messages

After power-up or a cold start, the servo amplifier is always in a "safe operating mode". In safe operating mode (-126), no motion functions can be triggered via PROFINET. However, it is possible to execute motion function using the commissioning software. If the operating mode is changed, motion functions can only be controlled via PROFINET. If the operating mode is changed via another communication channel, the drive is emergency braked and error F21 (handling error, expansion card) is signalled.

Results

Do not execute motion functions via the commissioning software, even in "safe mode".

9.2.3 Manufacturer-specific parameters

9.2.3.1 PNU 1000: Device ID

The device identifier consists of four ASCII characters.

9.2.3.2 PNU 1001: Manufacturer-specific error register

The following table shows the assignment of the error register and an explanation of the individual errors.

Bit	Description		Statement
0	Error F01:	Heat sink temperature	Heatsink temperature too high (default: 80°C)
1	Error F02:	Overvoltage	Overvoltage in the intermediate circuit. Limit value depends on the mains voltage
2	Error F03:	Position error	Message from the position controller
3	Error F04*:	Feedback	Open circuit, short circuit, earth fault
4	Error F05:	Undervoltage	Undervoltage in the intermediate circuit (default: 100 V)
5	Error F06*:	Motor temperature	Temperature sensor defective or motor temperature too high
6	Error F07*:	Internal voltage	Internal supply voltage faulty
7	Error F08:	Overspeed	Motor runs away, speed higher than permitted
8	Error F09*:	EEPROM	Check sum error
9	Error F10*:	Reserved	Reserved
10	Error F11*:	Motor Brake	Open circuit, short circuit, earth fault
11	Error F12*:	Motor phase	Motor phase missing (open circuit or similar)
12	Error F13:	Ambient temperature	Ambient temperature too high
13	Error F14*:	Output stage	Fault in the power output stage
14	Error F15:	I ² t max.	I ² t maximum value exceeded
15	Error F16:	Mains BTB	2 or 3 infeed phases missing

Bit	Description		Statement
16	Error F17*:	A/D converter	Error in the analogue/digital conversion, often caused by very strong electromagnetic interference
17	Error F18*:	Brake chopper	Brake circuit defective or incorrect setting
18	Error F19:	Intermediate circuit	Voltage drop in the intermediate circuit
19	Error F20*:	Expansion card error	Slot error, depends on the expansion card that's used, see ASCII command reference
20	Error F21*:	Handling error	Handling error on the expansion card
21	Error F22:	Reserved	Reserved
22	Error F23:	CAN Bus off	Major CAN Bus communication error
23	Error F24:	Warning	Warning indicator assessed as an error
24	Error F25:	Commutation error	Commutation error
25	Error F26:	Limit switch	Reference run error (hardware limit switch reached)
26	Error F27:	STO	Operational error with STO, STO-ENABLE and ENABLE inputs set simultaneously
27 - 30	Error F28 – F31*:	Reserved	Reserved
31	Error F32*:	System error	System software responds incorrectly

When the cause of the error has been rectified, the error state can be cleared by setting Bit 7 in the control word. The servo amplifier's reaction to a reset varies depending on the error:

For those errors marked with an asterisk (*), setting the reset bit causes the drive to cold start, during which PROFINET communication with this device is interrupted for several seconds. This break in communication must be handled separately in the PLC program. With the other error messages a reset leads to a warm start, whereby communication is not interrupted.

The operating manual for the servo amplifier contains a description of the individual errors and suggestions for how to rectify them.

9.2.3.3 PNU 1002: Manufacturer-specific status register

The table below shows the bit assignment for the status register:

Bit	Description
0	Warning 1: I ² t signal threshold exceeded
1	Warning 2: Set brake power has been reached
2	Warning 3: Set drag error window has been exceeded
3	Warning 4: Reaction monitoring (fieldbus) active
4	Warning 5: Input phase missing
5	Warning 6: Software end switch 1 exceeded
6	Warning 7: Software end switch 2 exceeded
7	Warning 8: An invalid motion task has been started
8	Warning 9: No reference point was set when the motion task was started
9	Warning 10: PSTOP end switch operated
10	Warning 11: NSTOP end switch operated
11	Warning 12: HIPERFACE® or EnDat®: Motor default values were loaded
12	Warning 13: Expansion card is not working properly
13	Warning 14: SinCos commutation not executed
14	Warning 15: Fault as per speed/current table INXMODE 35
15	Warning 16: Reserved
16	Motion task active (set as long as position control task is active – motion block, jog mode, reference run)
17	Reference point set (set after a reference run or when an absolute encoder is used (multiturn)); cleared when the amplifier is switched on or a reference run is started)
18	Current position = Home position (set as long as the reference switch is assigned)
19	In position (set as long as the distance between the target position of a motion task and the current actual position is less than PEINPOS. The in-position message is suppressed if a following motion task is started at the target position.)

Bit	Description
20	Position latch (positive edge) is set if a rising edge is detected at INPUT2 (IN2-MODE = 26), which is configured as a latch input. It is cleared if the INPUT2 position configured as the latch input is read out (LATCH16/LATCH32)
21	--
22	Position 1 reached (set if the condition configured for this message (SWCNFG, SWE1, SWE1N) is met. Depending on the configuration, this bit is set when SWE1 is exceeded, when the value of SWE1 is below the set value, when the position window SWE1 ... SWE1N is reached or when the position window SWE1 ... SWE1N is exited)
23	Position 2 reached (see above)
24	Position 3 reached (see above)
25	Position 4 reached (see above)
26	Initialisation complete (set when the internal initialisation of the amplifier is complete)
27	--
28	Speed = 0 (set as long as the motor speed is below the standstill threshold (VELO))
29	Safety relay has energised (set as long as the safety relay is open (AS))
30	Output stage enabled (set if the software and hardware enables are set)
31	Error is present (cleared when the amplifier is switched on or if the "Clear error" function is called)

Bits 16 to 31 of the manufacturer-specific status register are output in the process data.

Warnings 3 and 4 can be cleared via Bit 13 in the control word.

9.2.4 Position control parameters



INFORMATION

Due to the internal representation of the position control parameters, the position controller can only be operated if the final speed of the drive does not exceed the following values:

Rotary

Sinusoidal²-shaped acceleration: max. 7500 rpm

Trapezoidal acceleration: max. 12000 rpm

Linear

Sinusoidal²-shaped acceleration: max. 4 m/s

Trapezoidal acceleration: max. 6.25 m/s



INFORMATION

All the data regarding resolution, incremental value, positioning accuracy etc. refers to the arithmetic values. Non-linearities in the mechanics (backlash, elasticity etc.) are considered.

If the motor's end speed needs to be changed, all the position control and motion block parameters that were entered previously will need to be adapted.

9.2.4.1 PNU 1894: Speed multiplier

This parameter is used to enter a multiplier for the jog/referencing speed. When jog/referencing mode is started, the jog/referencing speed is stated via PZD2 in the control word. The actual jog speed is calculated using the following formula:

$$V_{\text{Jog,Overall}} (32\text{Bit}) = V_{\text{Jog,PZD2}} (16\text{Bit}) \times \text{Speed multiplier} (16\text{Bit})$$

The default value is 1.

9.2.4.2 PNU 1807: Axis type

This parameter is used to state the drive's axis type.

Value	Type
0	Linear axis
1	Module axis
2	Reserved

9.2.5 Positioning data for position controller mode

9.2.5.1 PNU 1790: Position

For all positioning operations, the servo amplifier calculates internally only on an incremental basis, so there are limitations in the usable value range for distances that are stated in SI units.

The range for the incremental position covers values from -2^{31} to $(2^{31}-1)$. The resolution defined by the parameter PGEARO (PNU1803 Ind. 1) and PGEARI (PNU 1802 Ind. 1) and the variable PRBASE determine the sensible, usable range for positioning operations.

The variable PRBASE determines the number of increments per motor revolution via the equation $n = 2^{PRBASE}$. The value PRBASE can only be 16 or 20. PGEARO contains the number of increments that are traversed when the distance to be covered is PGEARI. The default values for PGEARO correspond to one revolution. The figures for calculating the revolutions that can be recorded are given as follows:

$-2048 \dots +2047$ for PRBASE = 16 and $-32768 \dots +32767$ for PRBASE = 20

Usable position range:

$-2^{31} * PGEARI/PGEARO \dots (2^{31} - 1) * PGEARI/PGEARO$ for $PGEARI \leq PGEARO$ or
 $-2^{31} \dots (2^{31} - 1)$ for $PGEARI > PGEARO$

9.2.5.2 PNU 1791: Speed

The usable range for speed is limited by the maximum navigable speed n_{max} , which was specified by the speed parameter VLIM as the end speed for the motor.

Maximum speed:

$V_{SI,max} = n_{max} * PGEARI/PGEARO * 2^{PRBASE}$ with n_{max} in rps

Maximum speed incrementally:

$V_{incr,max} = n_{max} + 2^{PRBASE} + 250ms/1sek = n_{max}/4000 * 2^{PRBASE}$ with n_{max} in rps

9.2.5.3 PNU 1785: Motion task type

Bit	Value	Meaning
0	0	The stated position value is evaluated as the absolute position.
	1	The stated position value is evaluated as the relative travel distance; the two bits that follow determine the type of relative motion.
1	0	If Bit 1 and Bit 2 are 0 and Bit 0 is 1, the relative motion task is executed based on the "InPosition" bit.
	1	The new target position results from the old target position plus the travel distance. Bit 1 has priority over Bit 2.
2	0	If Bit 1 and Bit 2 are 0 and Bit 0 is 1, the relative motion task is executed based on the "InPosition" bit.
	1	The new target position results from the current actual position plus the travel distance.

Bit	Value	Meaning
3	0	There is no subsequent motion task.
	1	There is a subsequent task, which must be defined via the parameter O_FN, PNU 1788.
4	0	Switch to the subsequent task, with braking to 0 speed at the target position.
	1	Switch to the subsequent motion task, without standstill at the target position. The type of speed transition is set via Bit 8.
5	0	Switch to the subsequent task without evaluating the inputs.
	1	A subsequent motion task is started via an input that is configured accordingly.
6	0	Start the subsequent motion task via Input – Low state or if Bit 7 = 1, always after the delay time set via PNU 1789.
	1	Start the subsequent motion task via Input – High state or if Bit 7 = 1, always after the delay time set via PNU 1789.
7	0	The subsequent motion task is started immediately.
	1	The subsequent motion task is started after the waiting period set via PNU 1789 or if Bit 6 = 1, even earlier through a corresponding input signal.
8	0	Only with subsequent motion tasks and when Bit 4 = 1: from the target position of the preceding motion task, the speed is changed to the value of the subsequent task.
	1	The speed is switched in such a way that the speed in the target position of the preceding motion task reaches the value defined in the subsequent task.
9	---	Reserved
10		
11		
12	0	Accelerations are calculated using the start-up and braking times for the motion task.
	1	The acceleration and braking ramps are interpreted in mm/s ² .
13	0	The target position and target speed of a motion task are interpreted as increments.
	1	The target position and target speed are converted into increments before starting the motion task. The parameters PGEARI and PGEARO are used for this purpose.
14	0	The programmed speed is used as the motion task speed.
	1	The motion task speed is determined by the voltage present at analogue input 1 when the motion task is started.
15	---	Reserved
16	0	A trapezoidal motion block is started.
	1	A trapezoidal motion block (sinusoidal2 motion) is started. Bit 9 must be set to 0.

When direct motion blocks are used in "Positioning" operating mode, Bits 0 to 15 are transmitted in PZD6 as motion block type.

Bit 16 is not influenced by the motion block type transmitted with the process data in PZD 6 and so must be written in the parameter channel via PNU 1785.

9.2.5.4 PNU 1783: Acceleration time

This parameter is used to state the overall time it takes to go from 0 speed to the motion task's target speed.

9.2.5.5 PNU 1786: Delay time

This parameter is used to state the overall time it takes to bring the speed to the target position at 0.

9.2.5.6 PNU 1788: Subsequent motion task

The motion block number of the motion task to be started can be in the ranges 1 to 200 (EEPROM – motion tasks) or 201 to 300 (RAM motion tasks).

9.2.5.7 PNU 1789: Start delay

This parameter is used to set a delay time, with which to start a subsequent motion task.

9.2.5.8 PNU 1310: Copy motion task

This parameter can be used to copy motion tasks. The source motion task must be entered in PWE's high value (Byte 5 & 6) and the target motion task in PWE's low value (Byte 7 & 8).

9.2.6 Setup mode, position

9.2.6.1 PNU 1773 Reference run type

This parameter can be used to determine the type of reference run to use. The assignment can be taken from the following table:

PWE	Reference run type
0	Reference point at the current position
1	Initiator with resolver zero point
2	Hardware limit switch with resolver zero point
3	Initiator without resolver zero point
4	Hardware limit switch without resolver zero point
5	Zero point feedback unit
6	Reference point at actual position
7	Hardware stop with resolver zero point
8	Absolute SSI position
9	Up to stop without zero point search

9.2.6.2 PNU 1644 Reference run direction

This parameter can be used to determine the travel direction for reference runs. If 0 is transferred as the parameter value, the travel direction will be negative; with 1 it will be 1 positive and with 2, the direction in which the reference run starts depends on the distance to the reference point.

9.2.7 Actual values

9.2.7.1 PNU 1800: SI position value

The parameter value is the current SI position value.

9.2.8 Digital I/O configuration

All the settings for the digital inputs and outputs only take effect once they are saved in the EEPROM and the servo amplifier has been switched off / on or cold started. The meanings of these functions and potentially other functions are explained in the commissioning software's online help, in the integrated list of ASCII commands.

9.2.8.1 PNUs 1698/1701/1704/1707 Function of the digital inputs

This parameter can be used to configure digital inputs 1 to 4 of the servo amplifier individually. The "Activating edge" column describes the signal required at the digital input in order to trigger the corresponding function. The configurable functions depend on the amplifier you are using and are described in the ASCII object reference.

9.2.8.2 PNUs 1775/1778 Function of the digital outputs

This parameter can be used to configure the two digital outputs of the servo amplifier individually. Details of further functions can be found in the commissioning software's online help and in the list of ASCII commands. The configurable functions depend on the servo amplifier you are using and are described in the ASCII object reference.

9.2.9 Analogue configuration

All the settings for the analogue inputs and outputs only take effect once they are saved in the EEPROM and the servo amplifier has been switched off / on or cold started. The meanings of the functions are explained in the commissioning software's online help.

9.2.9.1 PNU 1607: Configuration of the analogue input functions

This parameter can be used to configure both analogue inputs together. The configurable functions depend on the amplifier you are using and are described in the ASCII object reference.

9.2.10 Manufacturer-specific object channel (from PNU 1600)

With PNUs > 1600, all ASCII parameters/commands on the servo amplifier are accessible. The PNU can be calculated from the object number (ASCII list: DPR) with an offset. All the PNUs described in this document can be addressed with Index = 1 (for specification see [In-](#)

dex IND [ 34]). You will find the PNU and corresponding index for each parameter in the ASCII command list. Additional functions of the object channel can be used with the indices described below.

The offset and the indices to be used depend on the object number:

Object number	Offset	PNUs	Index
0 ... 447	1600	1600 ... 2047	00h ... 08h (1 ... 8dec)
448 ... 847	1200	1648 ... 2047	10h ... 18h (16 ... 24dec)
847 ... 1047	800	1648 ... 2047	20h ... 28h (32 ... 40dec)

Index	0/10h/20h depending on the object number, see above
Brief description	Number of inputs
Device	---
Access	ro
Data type	UNSIGNED8
Value range	8
EEPROM	---

Index	1/11h/21h depending on the object number, see above
Brief description	Read/write a parameter
Device	See respective ASCII command
Access	See respective ASCII command
Data type	See respective ASCII command
Value range	See respective ASCII command
Default value	---
EEPROM	See respective ASCII command

Index	2/12h/22h depending on the object number, see above
Brief description	Read the lower limit value
Device	See respective ASCII command
Access	Read-only
Data type	See respective ASCII command
Value range	See respective ASCII command
Default value	---
EEPROM	---

Index	3/13h/23h depending on the object number, see above
Brief description	Read the upper limit value
Device	See respective ASCII command
Access	Read-only
Data type	See respective ASCII command
Value range	See respective ASCII command
Default value	---
EEPROM	---

Index	4/14h/24h depending on the object number, see above
Brief description	Read the default value
Device	See respective ASCII command
Access	Read-only
Data type	See respective ASCII command
Value range	See respective ASCII command
Default value	---
EERROM	---

Index	5/15h/25h depending on the object number, see above
Brief description	Read the default value
Device	---
Access	Read-only
Data type	See respective ASCII command
Value range	See respective ASCII command
Default value	---
EERROM	---

Description

The following object formats are possible:

- | | |
|---|--|
| 0 | Function (no parameters – only write access permitted) |
| 1 | Function (32 Bit parameter) |
| 2 | Function (32 Bit parameter with weighting 3) |
| 3 | 8 Bit integer |
| 4 | 8 Bit unsigned integer |
| 5 | 16 Bit integer |

6	16 Bit unsigned integer
7	32 Bit integer
8	32 Bit unsigned integer
9	32 Bit integer (weighting 3)

Index	6/16h/26h depending on the object number, see above
Brief description	Read object control data
Device	---
Access	Read-only
Data type	UNSIGNED32
Value range	0 ... $2^{32} - 1$
Default value	---
EEPROM	---

Description

0x00010000	When changed, the variable must be saved and the servo amplifier reset
0x00020000	Variable is saved in serial EEPROM.
0x00200000	Variable is read-only, may not be written via the bus.

Index	7/17h/27h and 8/18h/28h
Brief description	Reserved
Device	---
Access	Read-only
Data type	UNSIGNED32
Value range	0 ... $2^{32} - 1$
Default value	---
EEPROM	---



INFORMATION

Objects with object format 0 (Index 5) must not have read access (task identifier AK = 1).

10 Process data channel

The process data channel is used for real-time communication. This channel can be divided into two telegram sections:

- PZD1: **Control word (STW) status word (ZSW) – device control**
The control word and status word are used to control the device and monitor the device status.
- PZD2-6: **Setpoints/actual values based on the operating mode**
This is the section used to exchange setpoints and actual values such as position, speed and current.

The availability of a process data channel is established via the drive profile PROFIDRIVE. The meaning of the process data is defined in accordance with the operating mode. The process data that is used is determined in such a way as to optimise the real-time capability of this channel. In this case the "Selector switch for operating modes" parameter (see [Operating modes \(Opmodes\)](#)  63] is of key importance. It is used to select between individual operating modes. In the section that follows, the device control is explained first, followed by the meaning and functionality of the operating modes.

10.1 Device control

Device control is described using a state machine. The state machine is defined in the drive profile, via a flowchart for all operating modes. The diagram below shows the potential device states for the servo amplifier.

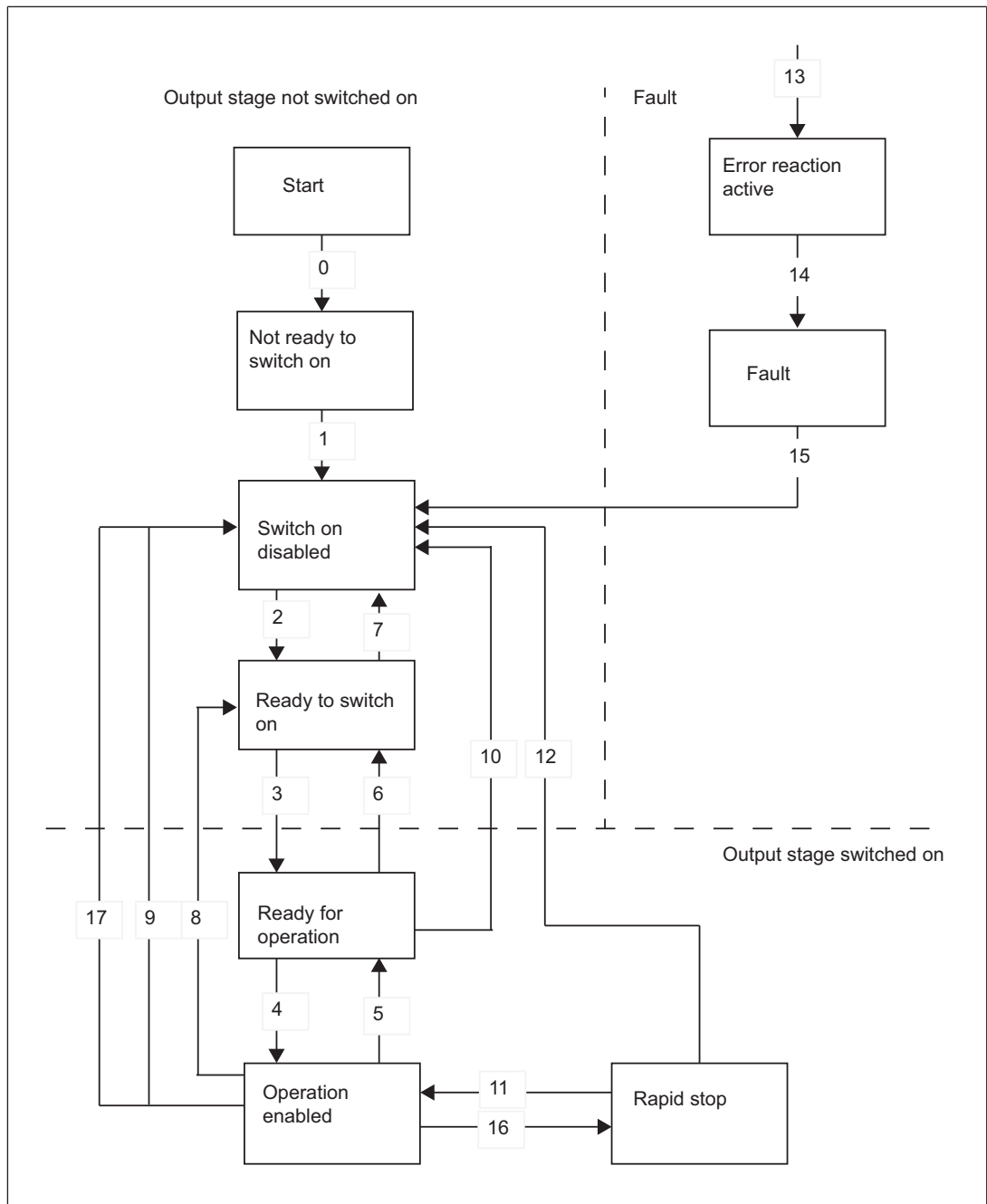

Fig.: Device control

The following tables describe the device states and transitions.

States of the state machine

State	Description
Not ready to switch on	Servo amplifier is not ready to switch on; the commissioning software has not signalled operational readiness (BTB).
Switch on disabled	Servo amplifier is ready to switch on, parameters can be transferred, intermediate circuit voltage can be switched on, motion functions cannot be executed yet.
Ready to switch on	Intermediate circuit voltage must be applied, parameters can be transferred, motion functions cannot be executed yet.
Ready for operation	Intermediate circuit voltage must be switched on, parameters can be transferred, motion functions cannot be executed yet, output stage is switched on.
Operation enabled	No error present, output stage is switched on, motion functions are enabled.
Rapid stop activated	Drive has been stopped with the emergency braking ramp, output stage is switched on (enabled), motion functions are enabled.
Error reaction active / error	Should a device error occur, the servo amplifier switches to the device state "Error reaction active". In this state the power element is switched off immediately. Once the error reaction has been executed, it switches to the "Error" state. This state can only be exited via the bit command "Error reset". To do this, the cause of the error must have been rectified (see ASCII command ERRCODE).

Transitions of the state machine

0	Event	Reset / 24 V operating voltage switched on.
	Action	Initialisation started.
1	Event	Initialisation completed successfully, servo amplifier switch on disabled.
	Action	None
2	Event	Bit 1 (disable voltage) and Bit 2 (rapid stop) set in the control word (command: shutdown). Intermediate circuit voltage is present.
	Action	None
3	Event	Bit 0 (switch on) is also set (command: switch on).
	Action	Output stage is switched on (enabled). Motor has torque.
4	Event	Bit 3 (operation enabled) is also set (command: operation enable).
	Action	Motion functions enabled, depending on the set operating mode.

5	Event	Bit 3 is cleared (command: disable).
	Action	Motion function is disabled. Motor is braked using the relevant ramp (depends on operating mode).
6	Event	Bit 0 is cleared (ready to switch on).
	Action	Output stage is switched off (disabled). Motor has no torque.
7	Event	Bit 1 or Bit 2 is cleared.
	Action	(Command: "Rapid stop" or "Disable voltage")
8	Event	Bit 0 is cleared (operation enabled → ready to switch on).
	Action	Output stage is switched off (disabled) – motor has no torque.
9	Event	Bit 1 is cleared (operation enabled → switch on disabled).
	Action	Output stage is switched off (disabled) – motor has no torque.
10	Event	Bit 1 or 2 is cleared (operation enabled → switch on disabled).
	Action	Output stage is switched off (disabled) – motor has no torque.
11	Event	Bit 4 is cleared (operation enabled → rapid stop).
	Action	Drive is stopped using the emergency braking ramp. The output stage remains "enabled". Setpoint values are cleared (e.g. motion block number, digital setpoint value).
12	Event	Bit 1 is cleared (rapid stop → switch on disabled).
	Action	Output stage is switched off (disabled) – motor has no torque.
13	Event	Error reaction is active.
	Action	Output stage is switched off (disabled) – motor has no torque.
14	Event	Error
	Action	None
15	Event	Bit 7 is set (error → switch on disabled).
	Action	Reset error (depending on the error – with / without reset).
16	Event	Bit 4 is set (rapid stop → enabled).
	Action	Motion function is re-enabled.
17	Event	Bit 2 is cleared.
	Action	Switch on disabled, output stage is disabled.

The state transitions are influenced by internal events (e.g. switching off the intermediate circuit voltage) and by the flags in the control word (Bit 0, 1, 2, 3, 7).

10.1.1 Control word (STW)

The control word is used to switch from one device state to another. The diagram of the state machine shows which device states can be achieved via which transitions. The current device state can be taken from the status word. It is possible to pass through several states in one telegram cycle, e.g. ready to switch on --- ready for operation --- operation enabled.

The bits in the control word may or may not be dependent on the operating mode.

The table below describes the bit assignment in the control word.

Bit	Name	Comment
0	Switching on	---
1	Disable voltage	---
2	Rapid stop, switch on disabled	1 → 0 drive brakes with emergency braking ramp, axis is disabled (see also ASCII commands STOPMODE and DECDIS).
3	Operation enabled	---
4	Rapid stop	1 → 0 drive brakes with emergency braking ramp.
5	Intermediate stop	Dependent on operating mode, 1 → 0 drive brakes.
6	Setpoint enable	Dependent on operating mode
7	Reset fault	Only effective in the event of errors.
8	Jog (on/off)	Dependent on operating mode
9	Reserved	---
10	PZD (enable / disable)	---
11	Start referencing (edge)	Dependent on operating mode
12	Manufacturer-specific	Position is reset.
13	Manufacturer-specific	Acknowledgement of warnings.
14	Manufacturer-specific	Only in position operating mode: Bit 14 = 1: PZD section is interpreted as a direct motion block (speed 32 Bit, position 32 Bit, motion block type 16 Bit, Bit 14 = 0: PZD section (HSW) is interpreted as a motion block number.
15	Manufacturer-specific	Dependent on operating mode, digital speed

A corresponding control command is defined, depending on the bit combination in the control word. The table below shows the bit combinations and at the same time determines the priorities of the individual bits, in case several bits in a telegram cycle are changed simultaneously.

Command	Bit 13	Bit 7	Bit 4	Bit 3	Bit 2	Bit 1	Bit 0	Transitions
Shutdown	X	X	X	X	1	1	0	2, 6, 8
Switching on	X	X	X	X	1	1	1	3
Disable voltage	X	X	X	X	X	0	X	7, 9,10,12
Rapid stop (disable)	X	X	X	X	0	1	X	11
Rapid stop (enable)	X	X	0	1	1	1	1	
Disable operation	X	X	X	0	1	1	1	5

Command	Bit 13	Bit 7	Bit 4	Bit 3	Bit 2	Bit 1	Bit 0	Transitions
Enable operation	X	X	1	1	1	1	1	4, 16
Reset error	X	1	X	X	X	X	X	15
Acknowledgement for warnings	1	X	X	X	X	X	X	--

Bits labelled with X are irrelevant.

Operating mode-dependent bits in the control word:

Operating mode	Bit 5	Bit 6	Bit 8	Bit 11
Position	Motion block: Uses the defined ramp from the motion block. Setup mode: Uses the ramp set as the parameter for the reference run and jogging.	Start a motion task with each pulse edge change (toggle bit).	Start jogging.	Start referencing.
Digital speed	Drive brakes with set speed ramps.	Setpoint enable	Reserved	Reserved
Digital current	Reserved	Setpoint enable	Reserved	Reserved
Analogue speed	Reserved	Reserved	Reserved	Reserved
Analogue current	Reserved	Reserved	Reserved	Reserved
Trajectory	Reserved	Reserved	Reserved	Reserved

Priority of Bits 6, 8, 11 in position controller mode: 6 (high), 11, 8 (low)

10.1.2 Status word (ZSW)

The status word is used to show the device state and verify the transmitted control word. If an unexpected state is registered as a result of a transmitted control word, all the boundary conditions for the expected device state must first be clarified (e.g. enable of output stage – Hardware and software, connection of intermediate circuit voltage).

The bits in the status word may or may not be dependent on the operating mode. The table below describes the bit assignment in the status word.

Bit	Name	Comment
0	Ready to switch on	---
1	Switched on	---
2	Operation enabled	---
3	Error	See ASCII command ERRCODE
4	Voltage disabled	---
5	Rapid stop	---
6	Switch on disabled	---
7	Warning	See ASCII command STATCODE
8	Monitoring of setpoint/actual value	Only in position operating mode: position error indicator
9	Remote	Not supported, fixed at 1
10	Setpoint achieved	Only in position operating mode: In position
11	Restriction active	Currently not supported.
12	Depends on operating mode	Used in ASCII mode
13	Depends on operating mode	Used in ASCII mode
14	Manufacturer-specific	Used in ASCII mode
15	Manufacturer-specific	Reserved

States of the state machine:

State	Bit 6	Bit 5	Bit 4	Bit 3	Bit 2	Bit 1	Bit 0
Not ready to switch on	0	X	X	0	0	0	0
Switch on disabled	1	X	X	0	0	0	0
Ready to switch on	0	1	X	0	0	0	1
Ready for operation	0	1	X	0	0	1	1
Operation enabled	0	1	X	0	1	1	1
Error	0	X	X	1	X	X	X
Error reaction	0	X	X	1	0	0	0

State	Bit 6	Bit 5	Bit 4	Bit 3	Bit 2	Bit 1	Bit 0
Rapid stop activated	0	0	X	0	1	1	1

10.2 Operating modes (Opmodes)

The selection of a new operating mode is described in detail in [PNU 930: Selector switch for operating modes](#) [42]. It is essential to follow and comply with this procedure.



CAUTION!

Motor drive starts up, material damage, less serious or minor injury
Avoid stating data formats incorrectly or standardising setpoints.

The section below describes the possible operating modes. Operating modes with positive numbers (1,2) are defined in the drive profile. Operating modes with negative numbers (-1, -2...) are labelled in the drive profile as manufacturer-specific operating modes.

10.2.1 Positioning (Opmode 2)

PZD 1	PZD 2	PZD 3	PZD 4	PZD 5	PZD 6
STW	Motion block number or Vset*	--	--	--	--
ZSW	n _{actual} (16 Bit)	Actual position (32 Bit)		Manufacturer-specific Status	--

* for jogging/referencing

Alternative assignment of the process data records when STW Bit 14 = 1:

PZD 1	PZD 2	PZD 3	PZD 4	PZD 5	PZD 6
STW	Direct motion task: Vset (32 Bit)	Setpoint position (32 Bit)		Motion block type	
ZSW	n _{actual} (16 Bit)	Actual position (32 Bit)		Manufacturer-specific Status	--

Motion block number

The motion block number of the motion task to be started can be in the ranges 1 to 200 (EEPROM motion tasks) or 201 to 300 (RAM motion tasks).

Setpoint speed (Vset)

Only for jog mode or reference run, PNU 1894 supplies the multiplier for this value, see [PNU 1894: Speed multiplier](#) [48].

Actual speed (16 Bit)

The presentation of the actual speed value is standardised to the parameter for overspeed VOSPD

$$n_{\text{actual}} = n_{\text{actual16}} / \text{VOSPD} / 2^{15}$$

Actual position (32 Bit)

The range for the incremental position covers values from -2^{31} to $(2^{31} - 1)$, where one revolution corresponds to 2^{PRBASE} increments.

Manufacturer-specific status

The upper 16 Bits of the manufacturer-specific status register (PNU 1002) are provided in the process data. Numbering starts again at 0. An explanation of the status register bits can be found in the table in [PNU 1002: Manufacturer-specific status register](#)  46].

Setpoint speed for direct motion task

The usable range for speed is not limited by the available data area. It is limited by the maximum navigable speed n_{max} , which was specified by the speed parameter VLIM as the end speed for the motor.

Maximum speed:

$$V_{\text{SI,max}} = n_{\text{max}} * \text{PGEARI} / \text{PGEARO} * 2^{\text{PRBASE}}$$

Maximum speed incrementally:

$$V_{\text{incr,max}} = n_{\text{max}} * 2^{\text{PRBASE}} * 250\text{ms} / 1 \text{ sec} = n_{\text{max}} / 4000 * 2^{\text{PRBASE}} \text{ in each case with } n_{\text{max}} \text{ in R/sec.}$$

Setpoint position for direct motion task

The servo amplifier calculates all position operations internally on an incremental basis only. For this reason there are limitations in the usable value range for distances stated in SI units. The range for the incremental position covers values from -2^{31} to $2^{31} - 1$. The resolution defined by the parameter 1803 (PGEARO) and 1802 (PGEARI) and the variable PRBASE determine the sensible usable range for positioning operations. The variable PRBASE determines the number of increments per motor revolution via the equation $n = 2^{\text{PRBASE}}$. The value PRBASE can only be 16 or 20. PGEARO contains the number of increments that are traversed when the distance to be covered is PGEARI. The default values for PGEARO are 1048576 (PRBASE = 20) or 65536 (PRBASE = 16) and correspond to one revolution. The following revolutions can be recorded for this setting:

-2048 ... +2047 for PRBASE = 20 or

-32768 ... +32767 for PRBASE = 16

The sensible, usable position range extends over the range:

$-2^{31} * \text{PGEARI} / \text{PGEARO}$ $(2^{31} - 1) * \text{PGEARI} / \text{PGEARO}$ for $\text{PGEARI} \leq \text{PGEARO}$ or

$-2^{31} .. (2^{31} - 1)$ for $\text{PGEARI} > \text{PGEARO}$

Motion block type

The various motion block types are described in [PNU 1785: Motion task type](#)  49].

10.2.2 Digital speed (Opmode 1)

PZD 1	PZD 2	PZD 3	PZD 4	PZD 5	PZD 6
STW	n_{set}	--	--		--
ZSW	n_{actual}	--	Incremental actual position 32 Bit		Manufacturer-specific Status

Alternative assignment of the process data records when STW Bit 14 = 1:

PZD 1	PZD 2	PZD 3	PZD 4	PZD 5	PZD 6
STW	n_{set} (32 Bit)		--		--
ZSW	n_{actual} (32 Bit)		Incremental actual position 32 Bit		Manufacturer-specific Status

Alternative assignment of the process data records when STW Bit 15 = 1:

PZD 1	PZD 2	PZD 3	PZD 4	PZD 5	PZD 6
STW	n_{set} (16 Bit)	--	--		--
ZSW	n_{actual} (16 Bit)	--	Position (20 Bit/rev. and 16 revolutions)		Manufacturer-specific Status

Actual speed (16 Bit)

The presentation of the actual speed value is standardised to the parameter for overspeed.

$$n_{\text{actual}} = (n_{\text{actual}16} * \text{VOSPD}) / 2^{15}$$

Actual position (32 Bit)

The range for the incremental position covers values from -2^{31} to $(2^{31} - 1)$, where one revolution corresponds to 2^{PRBASE} increments.

Speed setpoint value n_{set} (16 Bit)

The speed setpoint value is standardised to the parameter for overspeed VOSPD.

$$n_{\text{set}16} = n_{\text{set}} / \text{VOSPD} * 2^{15}$$

Position

The actual position value is an incremental actual position value with a resolution of 24 Bit. One revolution corresponds to 2^{PRBASE} increments. $2^{24 * \text{PRBASE}}$ revolutions can be represented.

Speed values n_{set} (32 Bit)

Digital speed values are converted into speed values with the unit revolution per minute.

$$n_{\text{set/actual}} (\text{min}^{-1}) = n_{\text{set/actual,dig}} * (60 * 4000) / (32 * 2^{\text{PRBASE}} * 128)$$

With 2^{PRBASE} = increments per motor revolution, 60s/min,

4000: Number of position control cycles / second

10.2.3 Analogue speed (Opmode -1)

In this operating mode, the control word (STW) can only be used to set the drive to enable/disable.

PZD 1	PZD 2	PZD 3	PZD 4	PZD 5	PZD 6
STW	--	--	--	--	--
ZSW	n_{actual}	--	Incremental actual position 32 Bit		Manufacturer-specific Status

10.2.4 Digital torque (Opmode -2)

In this operating mode, the control word (STW) can only be used to set the drive to enable/disable.

PZD 1	PZD 2	PZD 3	PZD 4	PZD 5	PZD 6
STW	I_{set}	--	--	--	--
ZSW	$I_{\text{actual}} = IQ$	Incremental actual position (32 Bit, value range 24 Bit)		Manufacturer-specific Status	--

Actual position (32 Bit)

The range for the incremental position covers values from -2^{31} to $(2^{31} - 1)$, where one revolution corresponds to 2^{PRBASE} increments.

Manufacturer-specific status

The upper 16 Bits of the manufacturer-specific status register (PNU 1002) are provided in the process data. Numbering starts again at 0. An explanation of the status register bits can be found in the table in [PNU 1002: Manufacturer-specific status register](#)  46].

Digital current values (16 Bit)

The digital current values are converted:

$$I_{(\text{set})} [\text{mA}] = \text{Digital current setpoint} / 3280 * \text{DIPEAK} [\text{mA}]$$

(DIPEAK = device peak current)

10.2.5 Analogue torque (Opmode -3)

In this operating mode, the control word (STW) can only be used to set the drive to enable/disable.

PZD 1	PZD 2	PZD 3	PZD 4	PZD 5	PZD 6
STW	--	--	--	--	--
ZSW	$n_{\text{actual}} = IQ$	Incremental actual position (32 Bit, value range 24 Bit)		Manufacturer-specific Status	--

10.2.6 Electronic gearing (Opmode -4)

PZD 1	PZD 2	PZD 3	PZD 4	PZD 5	PZD 6
STW	--	--	--	--	--
ZSW	n_{actual16}	Actual position (32 Bit)		Manufacturer status	--

Actual speed (16 Bit)

The presentation of the actual speed value is standardised to the parameter for overspeed VOSPD

$$n_{\text{actual}} = n_{\text{actual16}} / \text{VOSPD} * 2^{15}$$

Actual position (32 Bit)

The range for the incremental position covers values from -2^{31} to $(2^{31} - 1)$, where one revolution corresponds to 2^{PRBASE} increments.

Manufacturer-specific status

The upper 16 Bits of the manufacturer-specific status register (PNU 1002) are provided in the process data. Numbering starts again at 0. An explanation of the status register bits can be found in the table in [PNU 1002: Manufacturer-specific status register](#) [46].

10.2.7 Trajectory (Opmode -5)

In this operating mode, the control word (STW) can only be used to set the drive to enable/disable.

PZD 1	PZD 2	PZD 3	PZD 4	PZD 5	PZD 6
STW	--	--	--	--	--
ZSW	n_{actual}	Incremental actual position (32 Bit)		Manufacturer status	--

Actual speed (16 Bit)

The presentation of the actual speed value is standardised to the parameter for overspeed VOSPD

$$n_{\text{actual16}} = n_{\text{actual}} / \text{VOSPD} * 2^{15}$$

Actual position (32 Bit)

The range for the incremental position covers values from -2^{31} to $(2^{31} - 1)$, where one revolution corresponds to 2^{PRBASE} increments.

10.2.8 ASCII channel (Opmode -16)

PZD 1	PZD 2	PZD 3	PZD 4	PZD 5	PZD 6
STW	10 Bytes of ASCII data				
ZSW	10 Bytes of ASCII data				

The ASCII channel operating mode is used to set parameters for the servo amplifier.

So ASCII data can be exchanged with the servo amplifier using the RS232 interface, as via any terminal program. Communication is controlled via handshake bits in the control word and status word.

The assignment is as follows:

Bit 12: Control word

Any pulse edge change at this bit informs the servo amplifier that there is valid ASCII data in its input process data section, i.e. at this point the control system must have entered valid data in the PZP send area PZD 2 – PZD 6.

Status word

The servo amplifier uses a pulse edge change at this bit to confirm that it has accepted the ASCII data.

Bit 13: Status word

The servo amplifier uses a "1" in this bit to signal that the ASCII buffer now contains valid data. A pulse edge change at Bit 14 in the control word STW prompts the servo amplifier to write the buffer contents to the PZD receive area on the bus master.

Bit 14: Control word

Any pulse edge change at this bit prompts the servo amplifier to write the contents of its full ASCII buffer to the receive process data on the bus master.

Status word

The servo amplifier uses a pulse edge change at this bit to confirm that the buffer containing the ASCII data has been written to the process data.

Please note the following when transmitting ASCII data:

- ▶ Each ASCII command must be terminated with the character string "CR LF".
- ▶ If the ASCII command (incl. CR LF) is shorter than the 10 characters available, the telegram must be filled with bytes containing 0x00.
- ▶ If ASCII commands are longer than 10 characters, they will need to be divided over several telegrams. The response buffer should be read by the time a maximum of 30 characters have been sent.

Please note the following when evaluating the responses to the transmitted ASCII commands:

- ▶ The ASCII response is always terminated with an "End of Text" (EOT = 0x04) character.
- ▶ Response telegrams can also contain fewer than 10 Bytes of payload data, although the response is still complete. In this case the telegram is filled with bytes containing 0x00.
- ▶ Once the buffer has been read, Bit 13 of the status word is reset to "0" until the buffer is filled again. In each case, the end identifier for the ASCII response is "End of Text".

10.2.9 Operating mode after power up (Opmode -126)

Although the state machine can be controlled in this state, no motion functions can be initiated (see Profile parameters).

11 Technical details

General	
Approvals	CE
PROFINET interface	
Number	2
Input device	256 Byte
Output	256 Byte
Transmission rates	100 MBit/s
Certification	PNO
Manufacturer's ID	092Fh
Connection	RJ45
Device type	Slave
Environmental data	
Ambient temperature	
Temperature range	0 - 40 °C
Storage temperature	
Temperature range	-25 - 55 °C
Condensation during operation	Not permitted
Protection type	
Mounting area (e.g. control cabinet)	IP54
Housing	IP20
Terminals	IP20
Potential isolation	
Potential isolation between	PROFINET and system voltage
Type of potential isolation	Functional insulation
Rated surge voltage	500 V
Mechanical data	
Material	
Front	Steel 1.4016
Top	Polyester film
Dimensions	
Height	140,8 mm
Width	18,4 mm
Depth	101,8 mm
Weight	86 g

Where standards are undated, the 2013-08 latest editions shall apply.

12 Order reference

Product type	Features	Order No.
PMC PROFINET expansion card	PROFINET expansion card	680150

13 Appendix

13.1 Setup examples

All examples apply for all servo amplifier types.

13.1.1 Zero telegram (for initialisation)

A zero telegram should be sent when starting communication via the parameter channel and following communication errors:

Byte 1	2	3	4	5	6	7	8
0000 0000	0000 0000	0000 0000	0000 0000	0000 0000	0000 0000	0000 0000	0000 0000
PKE		IND		PWE			

The servo amplifier responds by also setting the first 8 Bytes of the telegram to zero.

13.1.2 Setting the operating mode

After power up or after a reset, the servo amplifier is in operating mode -126, in which it cannot execute motion functions. In order to execute positioning operations (motion tasks, jog, reference run), it must be brought into positioning mode. The procedure is as follows:

- ▶ 1.) Set control word bit 10 (PZD1, Bit 10) to 0. This invalidates the process data for the servo amplifier.

Byte 9	10	11	12
xxxx x0xx	xxxx xxxx	xxxx xxxx	xxxx xxxx
STW		HSW	

- ▶ 2.) Send parameter-setting telegram to set the operating mode.

Byte 1	2	3	4	5	6	7	8
0011 0011	1010 0010	xxxx xxxx	xxxx xxxx	0000 0000	0000 0000	0000 0000	0000 0010
PKE		IND		PWE			

The bits in the PKE section have the following meaning:

Bit 0 to 10: PNU 930, Bit 12 to 15: AK 3 (see also Meaning of response identifiers)

The servo amplifier sends a response telegram with AK = 2 and mirrored (identical) values for PNU and PWE.

- ▶ 3.) The new operating mode is switched on by setting control word bit 10 to 1, this validates the process data.

If point 1.) is ignored, the servo amplifier sends a negative response (PKE/AK = 7):

Byte 1	2	3	4	5	6	7	8
0111 0011	1010 0010	0000 0000	0000 0000	0000 0000	0000 0000	0000 0000	0001 0001
PKE		IND		PWE			

The number transferred in the PWE section represents the error number; you can look it up in the table in Profile-specific error numbers with response identifier 7. In this case, error no. 17 "Not possible due to operating state" is registered.

13.1.3 Enabling the servo amplifier

The hardware enable signal must be present for the servo amplifier to be enabled via PROFINET. The enable can be issued by setting the bit combination for the "Operation enabled" state in the control word.

Byte 9	10	11	12
xxx0 x1xx	0011 1111	xxxx xxxx	xxxx xxxx
STW		HSW	

The servo amplifier feeds back the corresponding state in its status word or displays a warning or error message.

Byte 9	10	11	12
xxxx xx1x	0010 0111	xxxx xxxx	xxxx xxxx
STW		HSW	

13.1.4 Starting jog mode

The way in which jog mode is started is very similar to that of referencing. First of all, Bit 8 STW must be set. The jog speed is the product of the 16 Bit main setpoint value in PZD2 and the multiplier set via PNU 1894. The sign of the main setpoint value determines the direction of movement.

The reference point does not need to be set for jog mode.

13.1.5 Setting the reference point



CAUTION!

Movement of the axis, minor injury, material damage

The axis could travel to the hardware limit switch or the mechanical stop.

The software limit switches set in the servo amplifier may not be effective.

Make sure that the position of the reference point permits the following positioning operations.

The control bit 12 = 1 is used to declare the current position as the reference point. The positioning functions are enabled. The zero point displacement (NI-Offset) is ineffective. Feedback for "Reference point set" is provided via Bit 17 in the manufacturer-specific status register (PNU 1002) or Bit 1 (manufacturer status of process data).

Prerequisite:

- ▶ PNU930 ≠ 16
- ▶ No motion function active
Manufacturer-specific status, process data word 5 Bit 0

13.1.6 Starting the reference run



CAUTION!

Movement of the axis, minor injury, material damage

If the reference point (machine zero point) is approached too quickly, with high mass moments of inertia for example, it may be overrun and, in unfavourable conditions, the axis can travel up to the hardware limit switch and mechanical stop. The software limit switches set in the servo amplifier may not be effective.

When the 24V auxiliary voltage is switched on, a reference run must be carried out first.

Make sure that the position of the reference point permits the following positioning operations.

The reference run is started through STW, Bit 11 = 1. The start of the reference run is detected at the rising edge on Bit 16 in the manufacturer-specific status register. If Bit 11 is set to 0 again before the reference point is reached, the reference run is cancelled. Bit 17 of the manufacturer-specific status register remains at 0 (reference point not set).

A set reference point is a prerequisite for all positioning functions of the linear axis. The reference point switch is connected to a digital input on the servo amplifier. Depending on the reference run type, you can freely move the zero crossing point of the motor shaft within one revolution, using the zero point offset parameter. You can also define the actual position value on the reference point via the reference offset.

After the reference run, the drive signals that it is "In position" and enables the position controller. The speed of the reference run is transmitted with the main setpoint value (PZD2) as a 16 Bit value. The 32 Bit speed is determined by multiplying this with the value of the PNU 1894. The sign is not evaluated.

Prerequisite:

- ▶ States of the state machine = "Operation enabled"
- ▶ No warning message (ZSW Bit7=0)

The diagram below uses the example of reference run 1 (negative travel direction, positive direction of rotation, start point in negative direction from reference switch) to describe the signal characteristic of the relevant bits in the manufacturer-specific status.

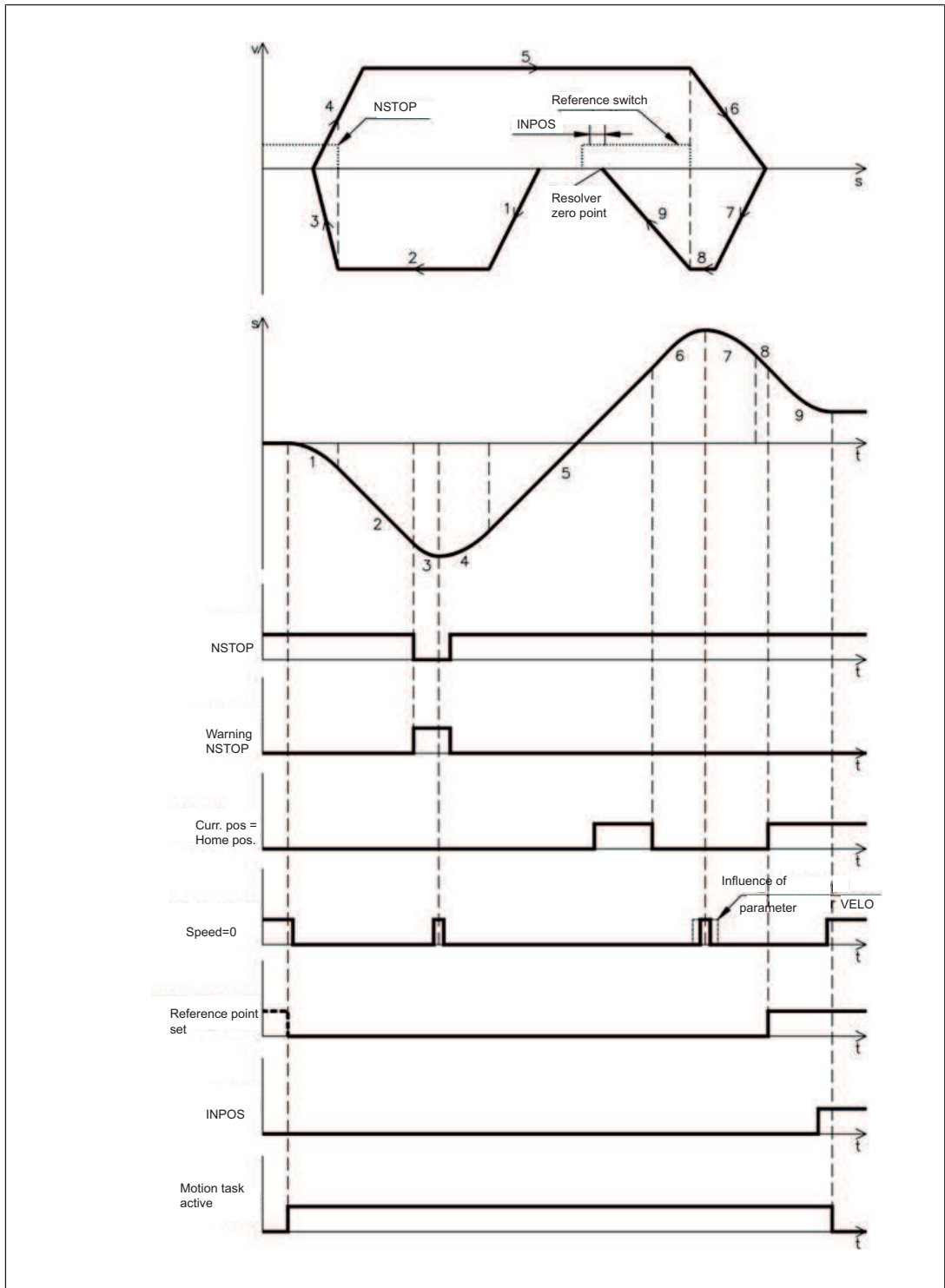

Once the reference run is completed, Bit 11 STW must be set back to 0. Alternatively the reference point can also be set at the actual position. This can be achieved by setting Bit 12 STW or by setting the reference run 0 with PNU1773 and then starting the reference run via Bit 11 STW.

13.1.7 Starting a motion task

Motion tasks can be started via an edge (rising or falling) at Bit 6 STW. Bit 12 STW is used to set whether a stored motion block or a direct motion task is to be started.

Prerequisites:

- ▶ Hardware enable is present
- ▶ Amplifier is in "Operation enabled" state. With linear axis: reference point has been set
- ▶ Intermediate circuit loaded

Example: Start the EEPROM motion task number 10:

Byte 9	10	11	12
0001 0000	0F*11 1111	0000 0000	0000 1010
STW		HSW	

*F stands for a pulse edge change, so the state of Bit 6 STW depends on the previous state.

By setting Bit 5 in the manufacturer-specific state, the amplifier indicates that it has accepted and executed the motion task.

13.1.8 Starting a direct motion task

If the motion block data is to be freely specified, a direct motion task must be used. In this case, the target position, speed and motion task type are transferred in the process data along with the motion task call. If necessary, additional parameters (e.g. ramps) for this direct motion task can be transferred beforehand via parameter tasks.

Target position	135000 μ m
Speed	20000 mm/s
Motion task type	<ul style="list-style-type: none"> ▶ Relative to the current actual position ▶ With subsequent motion task without intermediate stop ▶ Setpoint speed of the subsequent task should already have been reached at the target position (only makes sense if there is no change of direction) ▶ Use of SI units

Byte 1	2	3	4	5	6
0100 0100	0F*11 1111	0000 0000	0000 0000	0100 1110	0010 0000
PZ		PZD		PZ	
ST		v			

Byte 7	8	9	10	11	12
0000 0000	0000 0010	0000 1111	0101 1000	0010 0001	0001 1101
PZ		PZD		PZ	
L			Motion block		

*F stands for a pulse edge change, so the state of Bit 6 STW depends on the previous state.

13.1.9 Polling a warning or error message

If a warning or error message is present, parameter 1001 or 1002 can be used to poll the number of the warning / error.

13.1.10 Writing a parameter

Parameter v_max is used as an example to describe how control parameters are transferred from the master to the servo amplifier.

Parameter number **1816** 111 0001 1000
 Parameter value **350000** µm/s 0000 0000 0000 0101 0101 0111 0011 0000

Byte 1	2	3	4	5	6	7	8
0011 0111	0001 1000	0000 01000	0000 0000	0000 0000	0000 0101	0101 0111	0011 0000
PKE		IND		PWE			



INFORMATION

If an error occurs while transferring parameters (AK = 7), a "zero telegram" should be transmitted, i.e. the first 8 Bytes of the PLC send telegram should be kept at 0 until the servo amplifier has responded with a zero telegram.

13.1.11 Reading actual values

Cyclical request for actual value

This PKW task switches on reading of an actual value. The actual value will now be transmitted with each cyclical telegram – until a new PKW job is presented.

Telegram structure:

	Request	Response
PKE/AK	1	2
PKE/PNU	Parameter number of actual values	As transmitted
IND	0 = read	0
PWE	Irrelevant	Actual value

13.1.12 Writing a parameter via the ASCII channel

The KP value of the current controller should be set via the ASCII channel. The command is `MLGQ_1.985`. In this case the underscore represents a space. As each telegram only provides 10 positions for transferring ASCII characters, the termination of the line ("CR LF") must be transmitted in a second telegram.

Prerequisites:

- ▶ ASCII operating mode is switched on (PNU 930 = -16)
- ▶ Bit 13 STW = 0 (if necessary, toggle Bit 14 STW until Bit 13 ZSW = 0)

Procedure:

- ▶ Write data in PZD 2...6 and invert Bit 12 STW

Byte 1	2	3	4	5	6
0001 0000	0000 0000	0100 1101	0100 1100	0100 0111	0101 0001
PZD1		PZD2		PZD3	
STW		"M"	"L"	"G"	"Q"

Byte 7	8	9	10	11	12
0010 0000	0011 0001	0010 1110	0011 1001	0011 1000	0011 0101
PZD4		PZD5		PZD6	
"_"	"1"	":"	"9"	"8"	"5"

- ▶ Wait for pulse edge change at Bit 12 ZSW
- ▶ Continue to write data in PZD 2...6 and invert Bit 12 STW

Byte 1	2	3	4	5...12
0000 0000	0000 0000	0000 1101	0000 1010	0000 0000
PZD1		PZD2		PZD3 ...6
STW		"CR"	"LF"	

- ▶ Wait for pulse edge change at Bit 12 ZSW
- ▶ Wait until Bit 13 ZSW = 1
- ▶ Invert Bit 14 STW
- ▶ Wait until Bit 14 ZSW = 1
- ▶ The servo amplifier sends a response telegram

Byte 1	2	3	4	5	6
0110 0010	0000 0000	0100 1101	0100 1100	0100 0111	0101 0001
PZD1		PZD2		PZD3	
STW		"M"	"L"	"G"	"Q"

Byte 7	8	9	10	11	12
0010 0000	0011 0001	0010 1110	0011 1001	0011 1000	0011 0101
PZD4		PZD5		PZD6	
"_"	"1"	":"	"9"	"8"	"5"

- ▶ Repeat steps 5 to 8 until a response telegram signals "EOT".

**INFORMATION**

The sequence of response telegrams shown above is only one of many options (with an identical response from the servo amplifier). Depending on the transmission rate and internal synchronisation mechanisms, the situation may arise in which process data records remain empty and so the response is segmented. This may also change the number of response telegrams.

► Support

Technical support is available from Pilz round the clock.

Americas

Brazil
+55 11 97569-2804

Canada
+1 888-315-PILZ (315-7459)

Mexico
+52 55 5572 1300

USA (toll-free)
+1 877-PILZUSA (745-9872)

Asia

China
+86 21 60880878-216

Japan
+81 45 471-2281

South Korea
+82 31 450 0680

Australia

+61 3 95446300

Europe

Austria
+43 1 7986263-0

Belgium, Luxembourg
+32 9 3217575

France
+33 3 88104000

Germany
+49 711 3409-444

Ireland
+353 21 4804983

Italy
+39 0362 1826711

Scandinavia

+45 74436332

Spain

+34 938497433

Switzerland

+41 62 88979-30

The Netherlands

+31 347 320477

Turkey

+90 216 5775552

United Kingdom

+44 1536 462203

You can reach our international hotline on:

+49 711 3409-444
support@pilz.com

Pilz develops environmentally-friendly products using ecological materials and energy-saving technologies. Offices and production facilities are ecologically designed, environmentally-aware and energy-saving. So Pilz offers sustainability, plus the security of using energy-efficient products and environmentally-friendly solutions.



Pilz GmbH & Co. KG
Felix-Wankel-Straße 2
73760 Ostfildern, Germany
Tel.: +49 711 3409-0
Fax: +49 711 3409-133
info@pilz.com
www.pilz.com

