



▶ PST 4

PILZ

THE SPIRIT OF SAFETY

Operating Manual-18436-EN-10
- Safety relays



This document is the original document.

Where unavoidable, for reasons of readability, the masculine form has been selected when formulating this document. We do assure you that all persons are regarded without discrimination and on an equal basis.

All rights to this documentation are reserved by Pilz GmbH & Co. KG. Copies may be made for the user's internal purposes. Suggestions and comments for improving this documentation will be gratefully received.

CECE®, CHRE®, CMSE®, INDUSTRIAL PI®, Leansafe®, MYZEL®, PAS4000®, PAS-cal®, PASconfig®, Pilz®, PIT®, PMCprimo®, PMCprotego®, PM Ctendo®, PMD®, PMI®, PNOZ®, Primo®, PSEN®, PSS®, PVIS®, SafetyBUS p®, SafetyEYE®, SafetyNET p®, THE SPIRIT OF SAFETY® are registered and protected trademarks of Pilz GmbH & Co. KG in some countries.



SD means Secure Digital

Introduction	4
Validity of documentation	4
Using the documentation	4
Definition of symbols	4
Safety	5
Intended use	5
Safety regulations	5
Safety assessment	5
Use of qualified personnel	6
Warranty and liability	6
Disposal	6
For your safety	6
Unit features	7
Safety features	7
Block diagram/terminal configuration	7
Function Description	8
Operating modes	8
Timing diagram	9
Installation	9
Wiring	10
Preparing for operation	10
Operation	12
Status indicators	12
Faults – Interference	12
Dimensions in mm	13
Technical details	13
Safety characteristic data	17
Supplementary data	18
Service life graph	18
Order reference	19
EC declaration of conformity	19
UKCA-Declaration of Conformity	19

Introduction

Validity of documentation

This documentation is valid for the product PST 4. It is valid until new documentation is published.

This operating manual explains the function and operation, describes the installation and provides guidelines on how to connect the product.

Using the documentation

This document is intended for instruction. Only install and commission the product if you have read and understood this document. The document should be retained for future reference.

Definition of symbols

Information that is particularly important is identified as follows:



DANGER!

This warning must be heeded! It warns of a hazardous situation that poses an immediate threat of serious injury and death and indicates preventive measures that can be taken.



WARNING!

This warning must be heeded! It warns of a hazardous situation that could lead to serious injury and death and indicates preventive measures that can be taken.



CAUTION!

This refers to a hazard that can lead to a less serious or minor injury plus material damage, and also provides information on preventive measures that can be taken.



NOTICE

This describes a situation in which the product or devices could be damaged and also provides information on preventive measures that can be taken. It also highlights areas within the text that are of particular importance.

**INFORMATION**

This gives advice on applications and provides information on special features.

Safety**Intended use**

The safety relay PST 4 provides a safety-related interruption of a safety circuit.

The safety relay meets the requirements of EN 60947-5-1 and EN 60204-1 and may be used in applications with:

- ▶ Safety gates

Improper use

The following is deemed improper use in particular:

- ▶ Any component, technical or electrical modification to the product,
- ▶ Use of the product outside the areas described in this operating manual,
- ▶ Use of the product outside the technical details (see chapter entitled [Technical Details](#) [ 13]).

**NOTICE****EMC-compliant electrical installation**

The product is designed for use in an industrial environment. The product may cause interference if installed in other environments. If installed in other environments, measures should be taken to comply with the applicable standards and directives for the respective installation site with regard to interference.

Safety regulations**Safety assessment**

Before using a device, a safety assessment in accordance with the Machinery Directive is required.

The product as an individual component fulfils the functional safety requirements in accordance with EN ISO 13849 and EN IEC 62061. However, this does not guarantee the functional safety of the overall plant/machine. To achieve the relevant safety level of the overall plant/machine's required safety functions, each safety function needs to be considered separately.

Use of qualified personnel

The products may only be assembled, installed, programmed, commissioned, operated, maintained and decommissioned by persons who are competent to do so.

A competent person is a qualified and knowledgeable person who, because of their training, experience and current professional activity, has the specialist knowledge required. To be able to inspect, assess and operate devices, systems and machines, the person has to be informed of the state of the art and the applicable national, European and international laws, directives and standards.

It is the company's responsibility only to employ personnel who

- ▶ Are familiar with the basic regulations concerning health and safety / accident prevention,
- ▶ Have read and understood the information provided in the section entitled Safety
- ▶ Have a good knowledge of the generic and specialist standards applicable to the specific application.

Warranty and liability

All claims to warranty and liability will be rendered invalid if

- ▶ The product was used contrary to the purpose for which it is intended,
- ▶ Damage can be attributed to not having followed the guidelines in the manual,
- ▶ Operating personnel are not suitably qualified,
- ▶ Any type of modification has been made (e.g. exchanging components on the PCB boards, soldering work etc.).

Disposal

- ▶ In safety-related applications, please comply with the mission time T_M in the safety-related characteristic data.
- ▶ When decommissioning, please comply with local regulations regarding the disposal of electronic devices (e.g. Electrical and Electronic Equipment Act).

For your safety

The unit meets all the necessary conditions for safe operation. However, please note the following:

- ▶ Note for overvoltage category III: If voltages higher than low voltage (>50 VAC or >120 VDC) are present on the unit, connected control elements and sensors must have a rated insulation voltage of at least 250 V.

Function Description

The safety gate monitor PST 4 provides a safety-oriented interruption of a safety circuit. When operating voltage is supplied the "POWER" LED will light. The unit is ready for operation when the feedback loop Y1-Y2 and the start circuit S33-S34 are closed.

- ▶ Input circuit closed within the simultaneity period (safety gate closed)
 - The LEDs "CH.1 IN", "CH.2 IN" and "CH.1 OUT" and "CH.2 OUT" are lit
 - Safety contacts 13-14, 23-24, 33-34, 43-44, 53-54 and 63-64 are closed, auxiliary contacts 71-72, 81-82, 91-92 and 01-02 are opened. The unit is active.
- ▶ Input circuit is opened (safety gate opened)
 - The LEDs "CH.1 IN" and "CH.2 IN" go out.
 - Safety contacts 13-14, 23-24, 33-34, 43-44, 53-54 and 63-64 are opened redundantly, auxiliary contacts 71-72, 81-82, 91-92 and 01-02 are closed.
 - The LEDs "CH.1 OUT" and "CH.2 OUT" go out.

If the input circuits have already switched before supply voltage is applied, the PST 4 stops the plant being enabled, to prevent an automatic start-up in accordance with EN 60204 Pt 7.5.

Reset function

The safety contacts and auxiliary contacts remain in rest condition (safety contacts are open and auxiliary contacts are closed) if the supply voltage is applied when the safety gate is closed. The safety and auxiliary contacts are not activated until the safety gate has been opened and then closed again. N/C contacts in series with the safety gate limit switches S1 and S2 can simulate the opening of the safety gate.

Operating modes

- ▶ Dual-channel operation with detection of shorts across contacts: Redundant input circuit, PST 4 detects
 - earth faults in the start and input circuit,
 - short circuits in the input circuit,
 - shorts across contacts in the input circuit.
- ▶ Automatic start: Unit is active once the input circuit has been closed.
- ▶ Manual start: Unit is active once the input circuit and the start circuit are closed.
- ▶ Increase in the number of available contacts by connecting contact expansion modules or external contactors/relays.



NOTICE

The device does not recognise short circuits or shorts across contacts in the start/feedback loop. Take suitable measures, such as fault exclusion through protected or separate installation.

Timing diagram

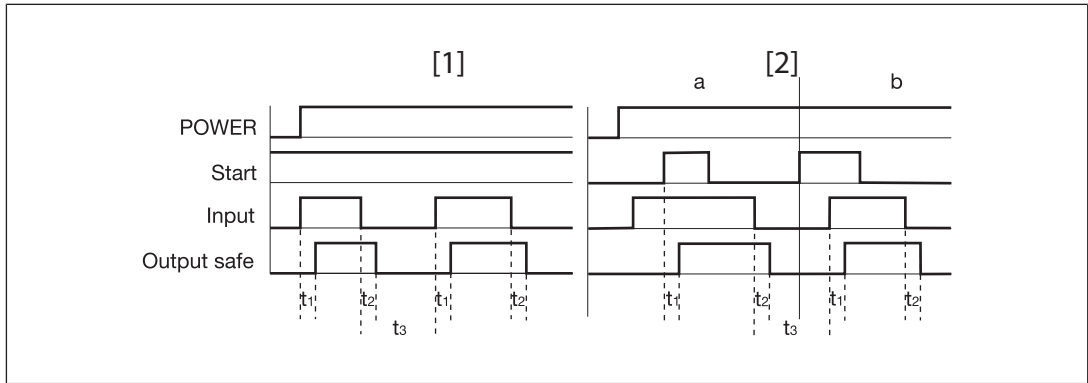

Legend

- ▶ Power: Supply voltage
- ▶ Start: Start circuit
- ▶ Input: Input circuits
- ▶ Output safe: Safety contacts
- ▶ [1]: Automatic start
- ▶ [2]: Manual start
- ▶ a: Input circuit closes before start circuit
- ▶ b: Start circuit closes before input circuit
- ▶ t_1 : Switch-on delay
- ▶ t_2 : Delay-on de-energisation
- ▶ t_3 : Recovery time

Installation

- ▶ Install the safety relay in a control cabinet with a protection type of at least IP54.
- ▶ Use the notch on the rear of the unit to attach it to a DIN rail (35 mm).
- ▶ When installed vertically: Secure the unit by using a fixing element (e.g. retaining bracket or end angle).

Wiring

Please note:

- ▶ Information given in the "[Technical details \[13\]](#)" must be followed.
- ▶ Outputs 13-14, 23-24, 33-34, 43-44, 53-54, 63-64 are safety contacts; outputs 71-72, 81-82, 91-92, 01-02 are auxiliary contacts (e.g. for display).
- ▶ Do **not** use auxiliary contacts 71-72, 81-82, 91-92, 01-02 for safety circuits!
- ▶ Do not connect undesignated terminals.
- ▶ To prevent contact welding, a fuse should be connected before the output contacts (see [Technical details \[13\]](#)).
- ▶ Calculation of the max. cable length l_{max} in the input circuit:

$$l_{max} = \frac{R_{lmax}}{R_l / km}$$

R_{lmax} = max. overall cable resistance (see [Technical details \[13\]](#))

R_l / km = cable resistance/km

- ▶ Use copper wiring with a temperature stability of 60/75 °C.
- ▶ To prevent EMC interferences (particularly common-mode interferences) the measures described in EN 60204-1 must be executed. This includes the separate routing of cables of the control circuits (input, start and feedback loop) from other cables for energy transmission or the shielding of cables, for example.
- ▶ Adequate protection must be provided on all output contacts with capacitive and inductive loads.
- ▶ Do not switch low currents using contacts that have been used previously with high currents.
- ▶ On 24 VDC devices:
The power supply must comply with the regulations for extra low voltages with protective electrical separation (SELV, PELV) in accordance with VDE 0100, Part 410.

Preparing for operation

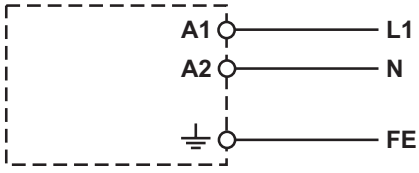
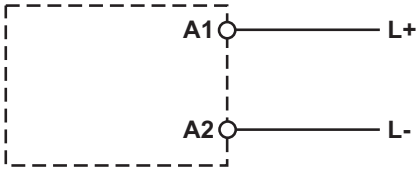
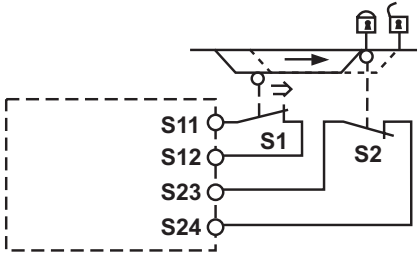
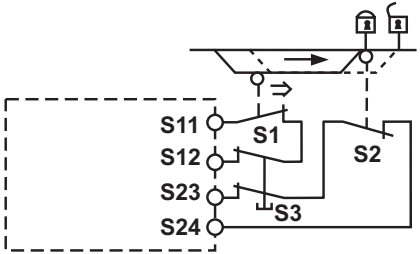
Supply voltage	AC	DC
		
Input circuit	Dual-channel	Dual-channel with reset function
Safety gate with detection of shorts across contacts		

Start circuit	Automatic start	Manual start



NOTICE

In the event of an automatic start or manual start with bridged start contact (fault):

The unit starts up automatically when the safeguard is reset, e.g. when the E-STOP pushbutton is released. Use external circuit measures to prevent an unexpected restart.

Feedback loop	Without feedback loop monitoring	With feedback loop monitoring
Link or contacts from external contactors		
Start-up testing		



INFORMATION

The feedback circuit must be closed at least 500 ms before limit switch S1 is operated and may only be opened once limit switch S1 has been operated.

Legend

- ▶ S1/S2: Safety gate switch
- ▶ S3: Start button
- ▶ ⤴: Switch operated
- ▶ : Gate open
- ▶ : Gate closed

Operation

When the relay outputs are switched on, the mechanical contact on the relay cannot be tested automatically. Depending on the operational environment, measures to detect the non-opening of switching elements may be required under some circumstances.

When the product is used in accordance with the European Machinery Directive, a check must be carried out to ensure that the safety contacts on the relay outputs open correctly. Open the safety contacts (switch off output) and start the device again, so that the internal diagnostics can check that the safety contacts open correctly

- ▶ for SIL 3/PL e at least 1x per month
- ▶ for SIL 2/PL d at least 1x per year



NOTICE

The safety functions should be checked after initial commissioning and each time the plant/machine is changed. The safety functions may only be checked by qualified personnel.

Status indicators

LEDs indicate the status and errors during operation:



LED on



POWER

Supply voltage is present.



CH.1 IN

Channel 1 input circuit is closed.



CH.2 IN

Channel 2 input circuit is closed.



CH.1 OUT

Channel 1 safety contacts are closed.



CH.2 OUT

Channel 2 safety contacts are closed.

Faults – Interference

- ▶ Earth fault: The supply voltage fails and the safety contacts open. Once the cause of the respective fault has been rectified and the supply voltage is switched off for approx. 1 minute, the unit is ready for operation again.
- ▶ Contact malfunctions: If the contacts have welded, reactivation will not be possible after the input circuit has opened.
- ▶ LED "POWER" does not light: Short circuit or no supply voltage.
- ▶ CH.1 OUT and CH.2 OUT do not light: Only one limit switch is closed. Simultaneity was not maintained.

Dimensions in mm

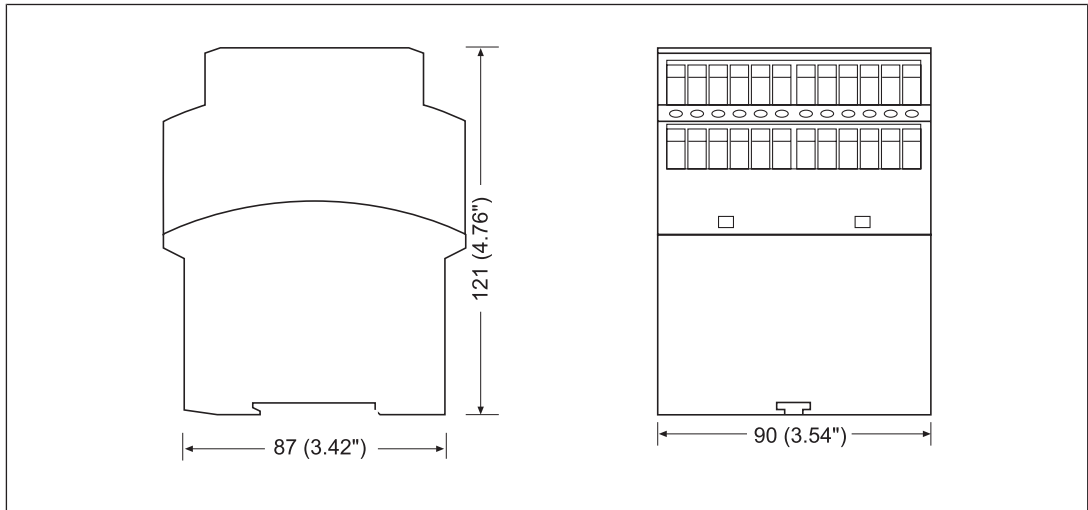

Technical details

Where standards are undated, the 2022-09 valid editions apply.

General	
Certifications	CCC, CE, EAC, TÜV, UKCA, cULus Listed
Electrical data	
Supply voltage	
Voltage	24 V
Kind	DC
Voltage tolerance	-15 %/+10 %
Output of external power supply (DC)	5,5 W
Residual ripple DC	20 %
Duty cycle	100 %
Max. inrush current impulse	
Current pulse, A1	10 A
Pulse duration, A1	0,5 ms
Inputs	
Quantity	2
Voltage at	
Input circuit DC	24 V
Start circuit DC	24 V
Feedback loop DC	24 V
Current at	
Input circuit DC	30 mA
Start circuit DC	30 mA
Feedback loop DC	30 mA
Max. overall cable resistance R _{lmax}	
Dual-channel with detection of shorts across contacts at UB DC	100 Ohm

Relay outputs

Number of output contacts

Safety contacts (N/O), instantaneous	6
Auxiliary contacts (N/C)	4

Max. short circuit current I_K **1 kA**

Utilisation category

in accordance with the standard **EN 60947-4-1**

Utilisation category of safety contacts

AC1 at	240 V *
Min. current	0,01 A
Max. current	8 A
Max. power	2.000 VA
DC1 at	24 V
Min. current	0,01 A
Max. current	8 A
Max. power	200 W

Utilisation category of auxiliary contacts

AC1 at	240 V
Min. current	0,01 A
Max. current	8 A
Max. power	2000 VA
DC1 at	24 V
Min. current	0,01 A
Max. current	8 A
Max. power	200 W

Utilisation category

in accordance with the standard **EN 60947-5-1**

Utilisation category of safety contacts

AC15 at	230 V
Max. current	5 A
DC13 (6 cycles/min) at	24 V
Max. current	7 A

Utilisation category of auxiliary contacts

AC15 at	230 V
Max. current	5 A
DC13 (6 cycles/min) at	24 V
Max. current	7 A

Utilisation category in accordance with UL

Voltage	240 V AC G. P.
with current	8 A
Voltage	24 V DC Resistive
with current	5 A
Pilot Duty	B300, R300

Relay outputs

External contact fuse protection, safety contacts

in accordance with the standard	EN 60947-5-1
Max. melting integral	240 A²s
Blow-out fuse, quick	10 A
Blow-out fuse, slow	6 A
Blow-out fuse, gG	10 A
Circuit breaker 24V AC/DC, characteristic B/C	6 A

External contact fuse protection, auxiliary contacts

Max. melting integral	240 A²s
Blow-out fuse, quick	10 A
Blow-out fuse, slow	6 A
Blow-out fuse, gG	10 A
Circuit breaker, 24 V AC/DC, characteristic B/C	6 A

Contact material **AgSnO₂ + 0,2 µm Au**

Conventional thermal current while loading several contacts

Ith per contact at UB AC; AC1: 240 V, DC1: 24 V

Conv. therm. current with 1 contact	8 A
Conv. therm. current with 2 contacts	7 A
Conv. therm. current with 3 contacts	5,7 A
Conv. therm. current with 4 contacts	5 A
Conv. therm. current with 5 contacts	4,4 A
Conv. therm. current with 6 contacts	4 A

Ith per contact at UB DC; AC1: 240 V, DC1: 24 V

Conv. therm. current with 1 contact	8 A
Conv. therm. current with 2 contacts	7 A
Conv. therm. current with 3 contacts	5,7 A
Conv. therm. current with 4 contacts	5 A
Conv. therm. current with 5 contacts	4,4 A
Conv. therm. current with 6 contacts	4 A

Times

Switch-on delay

Typ. switch-on delay	100 ms
----------------------	---------------

Delay-on de-energisation

with E-STOP typ.	30 ms
with E-STOP max.	50 ms

Supply interruption before de-energisation **10 ms**

Simultaneity, channel 1 and 2 max. **4 s**

Environmental data

Climatic suitability **EN 60068-2-78**

Ambient temperature

Temperature range	-10 - 55 °C
-------------------	--------------------

Storage temperature

Temperature range	-40 - 85 °C
-------------------	--------------------

Environmental data

Climatic suitability	
Humidity	93 % r. h. at 40 °C
Condensation during operation	Not permitted
EMC	EN 60947-5-1, EN 61000-6-2, EN 61326-3-1
Vibration	
in accordance with the standard	EN 60068-2-6
Frequency	10 - 55 Hz
Amplitude	0,35 mm
Airgap creepage	
in accordance with the standard	EN 60947-1
Overvoltage category	III / II
Pollution degree	2
Rated insulation voltage	250 V *
Rated impulse withstand voltage	4 kV
Protection type	
Housing	IP40
Terminals	IP20
Mounting area (e.g. control cabinet)	IP54

Mechanical data

Mounting position	Any
Mechanical life	10,000,000 cycles
Material	
Bottom	PPO UL 94 V1
Front	PMMA
Top	PPO UL 94 V1
Connection type	Screw terminal
Mounting type	Fixed
Conductor cross section with screw terminals	
1 core flexible	0,2 - 4 mm², 24 - 10 AWG
2 core with the same cross section, flexible with crimp connectors, no plastic sleeve	0,2 - 2,5 mm², 24 - 14 AWG
2 core with the same cross section, flexible without crimp connectors or with TWIN crimp connectors	0,2 - 2,5 mm², 24 - 14 AWG
Torque setting with screw terminals	0,5 Nm
Stripping length with screw terminals	6 mm
Dimensions	
Height	87 mm
Width	90 mm
Depth	121 mm
Weight	530 g



NOTICE

*** Changed values**

In earlier versions of this operating manual, higher values were stated for AC1 for the utilisation category for safety contacts and for the rated insulation voltage. These have been corrected in this version.

Safety characteristic data



NOTICE

You must comply with the safety characteristic data in order to achieve the required safety level for your plant/machine.

Operating mode	EN ISO 13849-1: 2015	EN ISO 13849-1: 2015	EN IEC 62061 SIL CL/max.	EN IEC 62061 61508	EN/IEC 61511 61508	EN/IEC 61511 61508	EN ISO 13849-1: 2015
	PL	Category	SIL	PFH [1/h]	SIL	PFD	T _M [year]
–	PL e	Cat. 4	SIL 3	5,14E-09	SIL 3	4,98E-06	20

Explanatory notes for the safety-related characteristic data:

- ▶ T_M is the maximum mission time in accordance with EN ISO 13849-1. The value also applies as the retest interval in accordance with EN IEC 61508-6 and EN IEC 61511 and as the proof test interval and mission time in accordance with EN IEC 62061.

All the units used within a safety function must be considered when calculating the safety characteristic data.



INFORMATION

A safety function's SIL/PL values are **not** identical to the SIL/PL values of the products used and may differ from these.

Supplementary data



CAUTION!

It is essential to consider the relay's service life graphs. The relay outputs' safety-related characteristic data is only valid if the values in the service life graphs are met.

The PFH value depends on the switch frequency and the load of the relay output. If the service life graphs are not accessible, the stated PFH value can be used irrespective of the switch frequency and the load, as the PFH value already considers the relay's B10d value as well as the failure rates of the other components.

Service life graph

The service life graphs indicate the number of cycles from which failures due to wear must be expected. The wear is mainly caused by the electrical load; the mechanical load is negligible.

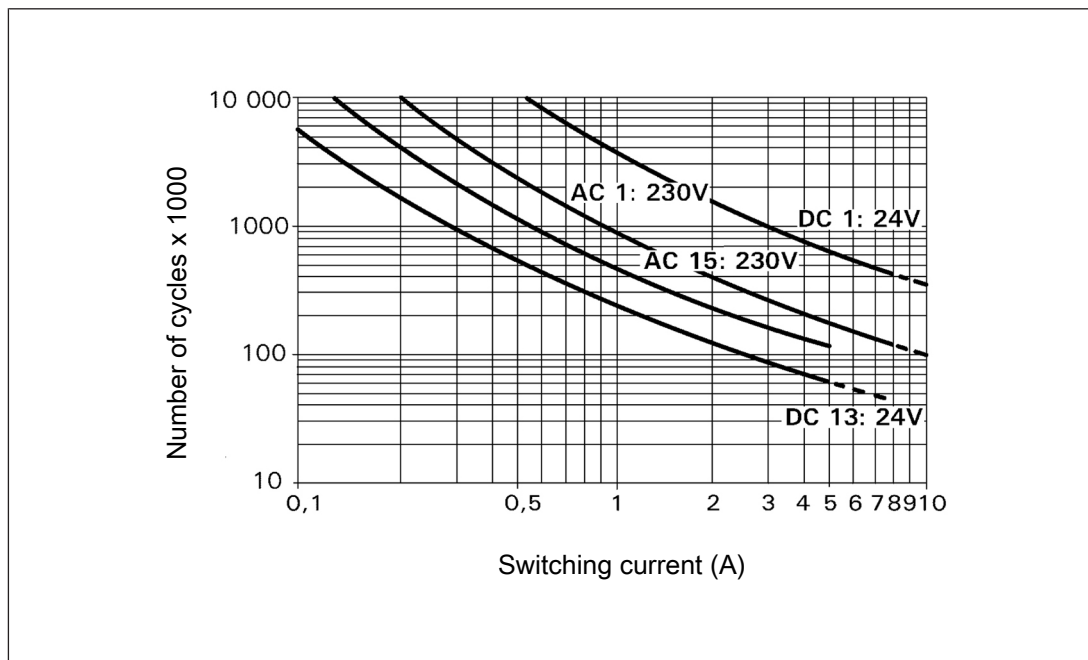

Example

- ▶ Inductive load: 0.2 A
- ▶ Utilisation category: AC15
- ▶ Contact service life: 4 000 000 cycles

Provided the application to be implemented requires fewer than 4 000 000 cycles, the PFH value (see Technical details) can be used in the calculation.

To increase the service life, sufficient spark suppression must be provided on all output contacts. With capacitive loads, any power surges that occur must be noted. With DC contactors, use flywheel diodes for spark suppression.

Order reference

Product type	Features	Connection type	Order no.
PST 4	24 V DC	Screw terminals	720300

EC declaration of conformity

This product/these products meet the requirements of the directive 2006/42/EC on machinery of the European Parliament and of the Council. The complete EC Declaration of Conformity is available on the Internet at www.pilz.com/downloads.

Representative: Pilz GmbH & Co. KG, Felix-Wankel-Str. 2, 73760 Ostfildern, Germany

UKCA-Declaration of Conformity

These products comply with following UK legislation: Supply of Machinery (Safety) Regulation 2008.

The complete UKCA Declaration of Conformity is available on the Internet at www.pilz.com/manuals.

Representative: Pilz Automation Technology, Pilz House, Little Colliers Field, Corby, Northamptonshire, NN18 8TJ United Kingdom, eMail: mail@pilz.co.uk

Support

Technical support is available from Pilz round the clock.

Americas

Brazil

+55 11 97569-2804

Canada

+1 888 315 7459

Mexico

+52 55 5572 1300

USA (toll-free)

+1 877-PILZUSA (745-9872)

Asia

China

+86 400-088-3566

Japan

+81 45 471-2281

South Korea

+82 31 778 3390

Australia and Oceania

Australia

+61 3 95600621

New Zealand

+64 9 6345350

Europe

Austria

+43 1 7986263-444

Belgium, Luxembourg

+32 9 3217570

France

+33 3 88104003

Germany

+49 711 3409-444

Ireland

+353 21 4804983

Italy, Malta

+39 0362 1826711

Scandinavia

+45 74436332

Spain

+34 938497433

Switzerland

+41 62 88979-32

The Netherlands

+31 347 320477

Türkiye

+90 216 5775552

United Kingdom

+44 1536 460866

You can reach our international hotline on:

+49 711 3409-222

support@pilz.com

Pilz develops environmentally-friendly products using ecological materials and energy-saving technologies. Offices and production facilities are ecologically designed, environmentally-aware and energy-saving. So Pilz offers sustainability, plus the security of using energy-efficient products and environmentally-friendly solutions.



We are represented internationally. Please refer to our homepage www.pilz.com for further details or contact our headquarters.

Headquarters: Pilz GmbH & Co. KG, Felix-Wankel-Straße 2, 73760 Ostfildern, Germany
Telephone: +49 711 3409-0, E-Mail: info@pilz.com, Internet: www.pilz.com

PILZ
THE SPIRIT OF SAFETY

CECE, CHRE, CMSE®, INDUSTRIAL Pi®, Leansafe®, Myze®, PAS4000®, PAScal®, PASconfig®, Pilz®, PIT®, PMCPirimo®, PMCProtecto®, PMCTiende®, PMP®, PMi®, PNOZ®, Primo®, PSEN®, PSS®, PVIS®, SafetyBUS p®, SafetyNET p®, THE SPIRIT OF SAFETY® are registered and protected trademarks of Pilz GmbH & Co. KG in some countries. We would point out that product features may vary from the details stated in this document, depending on the status at the time of publication and the scope of the equipment. We accept no responsibility for the validity, accuracy and entirety of the text and graphics presented in this information. Please contact our Technical Support if you have any questions.

18436-EN-10, 2026-03 Printed in Germany
© Pilz GmbH & Co. KG, 2024