



## ▶ PSS u2 ES 8DOD 0.5A (-R)

**PILZ**  
THE SPIRIT OF SAFETY

Operating Manual-1003614-EN-05

- PSS u2 in the automation system PSS 4000
- Remote I/O system PSS u2



This document is the original document.

Where unavoidable, for reasons of readability, the masculine form has been selected when formulating this document. We do assure you that all persons are regarded without discrimination and on an equal basis.

All rights to this documentation are reserved by Pilz GmbH & Co. KG. Copies may be made for the user's internal purposes. Suggestions and comments for improving this documentation will be gratefully received.

CECE®, CHRE®, CMSE®, INDUSTRIAL PI®, Leansafe®, MYZEL®, PAS4000®, PAS-cal®, PASconfig®, Pilz®, PIT®, PMCprimo®, PMCprotego®, PMctendo®, PMD®, PMI®, PNOZ®, Primo®, PSEN®, PSS®, PVIS®, SafetyBUS p®, SafetyEYE®, SafetyNET p®, THE SPIRIT OF SAFETY® are registered and protected trademarks of Pilz GmbH & Co. KG in some countries.



SD means Secure Digital

<b>1</b>	<b>Introduction</b> .....	<b>5</b>
1.1	Validity of documentation .....	5
1.2	Using the documentation .....	5
1.3	Terminology .....	5
1.4	Definition of symbols .....	6
<b>2</b>	<b>Overview</b> .....	<b>7</b>
2.1	Module features .....	7
2.2	Side view right-hand .....	8
<b>3</b>	<b>Safety</b> .....	<b>9</b>
3.1	Intended use .....	9
3.1.1	Third-party manufacturer licence information .....	11
3.2	Safety regulations .....	11
3.2.1	Additional documents that apply .....	11
3.2.2	Use of qualified personnel .....	11
3.2.3	Warranty and liability .....	12
3.2.4	Disposal .....	12
<b>4</b>	<b>Security</b> .....	<b>13</b>
4.1	Security (remote I/O system PSS u2) .....	13
4.2	Security (PSS u2 in the automation system PSS 4000) .....	13
<b>5</b>	<b>Function description</b> .....	<b>14</b>
5.1	Block diagram .....	14
5.2	Supply .....	14
5.3	Outputs .....	14
5.4	Reaction times .....	15
5.5	Energy-saving functions .....	15
<b>6</b>	<b>Structure of the process image Remote I/O (remote I/O system PSS u2)</b> .....	<b>16</b>
<b>7</b>	<b>I/O data of the module (PSS u2 in the automation system PSS 4000)</b> .....	<b>17</b>
7.1	Available I/O data in the I/O mapping .....	17
7.2	Other I/O data .....	17
<b>8</b>	<b>Installation</b> .....	<b>19</b>
8.1	General installation guidelines .....	19
8.1.1	Dimensions .....	20
8.2	Inserting and removing an electronic module .....	20
8.2.1	Inserting an electronic module .....	21
8.2.2	Removing an electronic module .....	23
8.2.3	Changing an electronic module during operation .....	24
<b>9</b>	<b>Wiring</b> .....	<b>25</b>
9.1	General wiring guidelines .....	25
9.1.1	Connection mechanism for terminal blocks .....	25
9.2	Terminal configuration .....	26

<b>10</b>	<b>Operation</b> .....	<b>27</b>
10.1	Display elements and messages .....	27
<b>11</b>	<b>Technical details</b> .....	<b>29</b>
<b>12</b>	<b>Supplementary data</b> .....	<b>32</b>
12.1	Operating height.....	32
<b>13</b>	<b>Order reference</b> .....	<b>33</b>
13.1	Product.....	33
13.2	Accessories.....	33
<b>14</b>	<b>EU/EC declaration of conformity</b> .....	<b>35</b>
<b>15</b>	<b>UKCA-Declaration of Conformity</b> .....	<b>36</b>

# 1 Introduction

## 1.1 Validity of documentation

This operating manual explains the function and operation, describes the installation and provides guidelines on how to connect the product.

This documentation is valid for the product PSS u2 ES 8DOD 0.5A from Version HW 1.1, FW 1.1. It is valid until new documentation is published.

This documentation is valid for the product PSS u2 ES 8DOD 0.5A -R from Version HW 1.1, FW 1.1. It is valid until new documentation is published.

## 1.2 Using the documentation

This document is intended for instruction. Only install and commission the product if you have read and understood this document. The document should be retained for future reference.

Please refer to the PSS u2 Installation Manual.

## 1.3 Terminology

### **PSS u2 system**

A PSS u2 system consists of a PSS u2 head module, main voltage supply module and optional PSS u2 electronic modules with backplanes.

### **Remote I/O system PSS u2**

PSS u2 system without control functionality that provides I/Os. The I/Os can be controlled via a fieldbus.

The configuration is performed in the tool PASconfig.

### **PSS u2 in the automation system PSS 4000**

A PSS u2 system can be used in the automation system PSS 4000. A PSS u2 system is a 2nd generation device in the automation system PSS 4000.

The configuration is performed in the tool PAS4000.

### **Basic type**

The basic versions of PSS u2 modules are called base type modules (e.g. PSS u2 EF 8DI).

### **R-type**

PSS u2 modules that are suitable for use with increased environmental requirements and railway applications are called R-type modules (e.g. PSS u2 EF 8DI -R).

## 1.4 Definition of symbols

Information that is particularly important is identified as follows:



### **DANGER!**

This warning must be heeded! It warns of a hazardous situation that poses an immediate threat of serious injury and death and indicates preventive measures that can be taken.



### **WARNING!**

This warning must be heeded! It warns of a hazardous situation that could lead to serious injury and death and indicates preventive measures that can be taken.



### **CAUTION!**

This refers to a hazard that can lead to a less serious or minor injury plus material damage, and also provides information on preventive measures that can be taken.



### **NOTICE**

This describes a situation in which the product or devices could be damaged and also provides information on preventive measures that can be taken. It also highlights areas within the text that are of particular importance.



### **INFORMATION**

This gives advice on applications and provides information on special features.

## 2 Overview

Module structure:

A module consists of

- ▶ an electronic module,
- ▶ a terminal block with cage clamp terminals and
- ▶ a module carrier

The electronic modules are plugged into the backplane and determine the function. The backplane is used for communication between the head module and the electronic modules and forms the carrier unit for the electronic modules. The terminal block is plugged into the electronic modules and is used to connect the field wiring.

Details of the terminal blocks that can be used are available under "Intended Use".

### 2.1 Module features

Application of the product PSS u2 ES 8DOD 0.5A (-R):

Electronic module with digital outputs and expanded diagnostics for standard applications

The product has the following features:

- ▶ 8 Digital outputs
  - Semiconductor technology
  - Single-pole
  - Positive-switching
  - Current load capacity per output: 0,5 A
  - Short circuit-proof
  - Overload-proof
- ▶ Energy-saving functions
- ▶ The module provides advanced diagnostic data:
  - Overload
  - Short circuit
  - Undervoltage
- ▶ LEDs for:
  - Switch status per output
  - Module error
  - Operating status
- ▶ **R-type:**  
for increased environmental requirements and railway applications

## 2.2 Side view right-hand

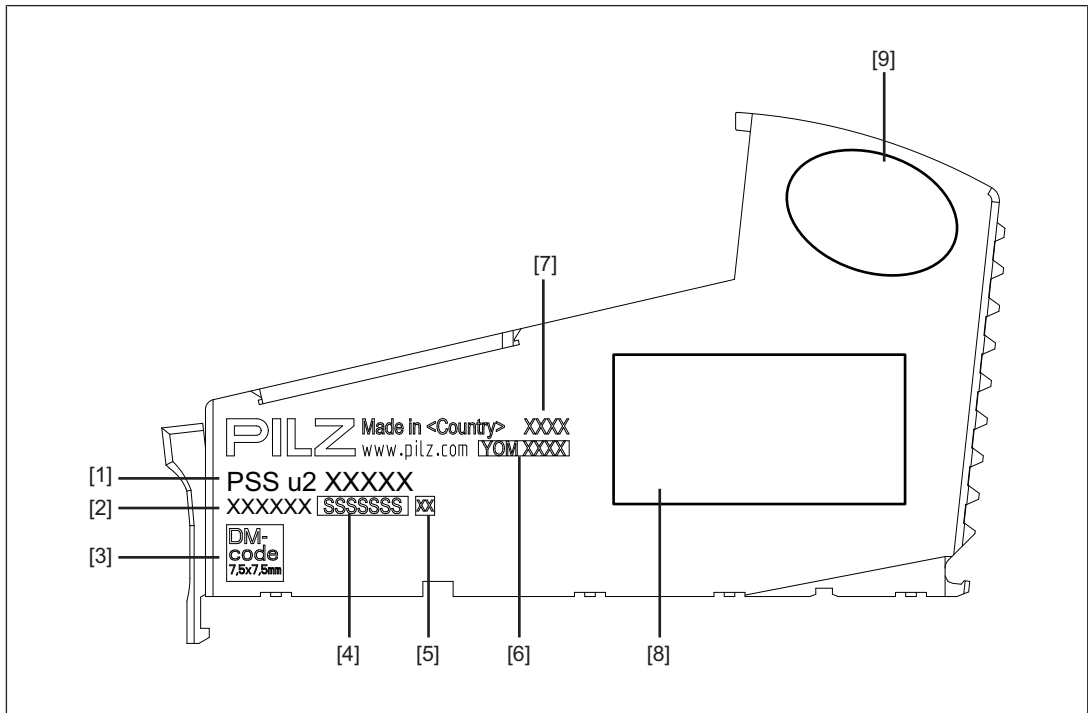

Fig.: Electronic module without terminal block, side view

### Legend

[1]	Product Name
[2]	Order number
[3]	2D code product information
[4]	Serial number
[5]	Hardware version
[6]	"YOM" year of manufacture
[7]	Production site
[8]	Placeholder for block diagram
[9]	Placeholder for approval tags

## 3 Safety

### 3.1 Intended use



#### INFORMATION

If the module name is not explicitly named, the details apply to all the variants of the module.

#### Use in a PSS u2 system

The module PSS u2 ES 8DOD 0.5A may be used in the following PSS u2 systems (see [Terminology](#) [ 5]):

- ▶ Remote I/O system PSS u2
- ▶ PSS u2 in the automation system PSS 4000 (generation 2)

The module PSS u2 ES 8DOD 0.5A -R may be used in the following PSS u2 system (see [Terminology](#) [ 5]):

- ▶ PSS u2 in the automation system PSS 4000 (2nd generation)

The module/backplane/safety controller should be installed in a protected environment, see documents:

- ▶ Installation Manual PSS u2 in the automation system PSS 4000 (1006253), under "Installation in a protected space"
- ▶ Installation Manual Remote I/O system PSS u2 (1004152), under "Installation in a protected space"

Make sure that only authorised personnel have access to the products.

#### Standard applications

The module may be used for standard applications.

#### Standard outputs

The module has standard outputs.

#### Application areas

- ▶ Use on machinery and in an industrial environment (2006/42/EC and EU 2023/1230)  
The modules PSS u2 ES 8DOD 0.5A (-R) can be used for **non-safety-related** applications (see [Technical details](#) [ 29]).

- ▶ Use in railway applications (CENELEC)

Depending on the selected railway architecture (see Safety Manual, under Safety architectures for railway applications (1006614)), the module PSS u2 ES 8DOD 0.5A -R meets the requirements of EN 50126, EN 50129, EN 50159, EN 50716 and EN 45545, safety category SIL 0 (basic integrity), (see [Technical details](#) [ 29]).

Only R-type modules may be used in a PSS u2 system for railway applications.

► Increased environmental requirements

The module PSS u2 ES 8DOD 0.5A -R is suitable for use where there are increased environmental requirements (see [Technical details](#)  29]).

Only R-type modules may be used in a PSS u2 system in applications with increased environmental requirements.

**Operating height**

With reference to the standard IEC 61131-2 the values stated in the technical details for ambient temperature are reduced at heights >2000 m operating height above sea level (see [Supplementary data](#)  32]).

**EMC-compliant installation**

Intended use includes making the electrical installation EMC-compliant. Please refer to the guidelines stated in the relevant installation manuals (see [Additional documents that apply](#)  11]).

**Improper use**

The following is deemed improper use in particular

- Any component, technical or electrical modification to the module,
- Use of the module outside the areas described in this operating manual,
- Any use of the module that is not in accordance with the technical details.

**Software tools**

The module PSS u2 ES 8DOD 0.5A is supported by:

- PASconfig from Version 1.0.0
- PAS4000 from Version 1.29.0

The module PSS u2 ES 8DOD 0.5A -R is supported by:

- PAS4000 from Version 1.29.0



**INFORMATION**

We recommend that you always use the latest version of the software tool (download from [www.pilz.com](http://www.pilz.com)).

**Backplane**

The module PSS u2 ES 8DOD 0.5A may be installed on the following backplanes:

- PSS u2 B 1
- PSS u2 B 4

The module PSS u2 ES 8DOD 0.5A -R may be installed on the following backplanes:

- PSS u2 B 1 -R
- PSS u2 B 4 -R

### **Terminal blocks**

The module may be used in conjunction with the following terminal block:

- ▶ 16-pin terminal block

## **3.1.1 Third-party manufacturer licence information**

The product contains open source software, whose terms of use could further limit the product's application area. It is essential that you observe the third-party manufacturer licence information.

Further information is available in the document "Third-party manufacturer licence information PSS u2 ES 8DID (-R)/PSS u2 ES 8DOD 0.5A (-R)" (document number 1007366) at [www.pilz.com](http://www.pilz.com).

## **3.2 Safety regulations**

### **3.2.1 Additional documents that apply**

Please read and take note of the following documents:

- ▶ Installation Manual remote I/O system PSS u2 (1004152)
- ▶ Installation Manual PSS u2 in the automation system PSS 4000 (1006253)
- ▶ System Description PSS 4000 (1001467)
- ▶ Safety Manual PSS 4000 (1001468)

With railway applications you should also refer to:

- ▶ Safety Manual, Safety Architectures for Railway Applications (1006614)

You will need to be conversant with the information in these documents in order to fully understand this operating manual.

### **3.2.2 Use of qualified personnel**

The products may only be assembled, installed, programmed, commissioned, operated, de-commissioned and maintained by persons who are competent to do so.

A competent person is a qualified and knowledgeable person who, because of their training, experience and current professional activity, has the specialist knowledge required. In order to inspect, assess and handle products, devices, systems, plant and machinery, this person must be familiar with the state of the art and the applicable national, European and international laws, directives and standards.

It is the company's responsibility only to employ personnel who

- ▶ Are familiar with the basic regulations concerning health and safety / accident prevention,
- ▶ Have read and understood the information provided in the section entitled Safety
- ▶ Have a good knowledge of the generic and specialist standards applicable to the specific application.

### **3.2.3 Warranty and liability**

All claims to warranty and liability will be rendered invalid if

- ▶ The product was used contrary to the purpose for which it is intended,
- ▶ Damage can be attributed to not having followed the guidelines in the manual,
- ▶ Operating personnel are not suitably qualified,
- ▶ Any type of modification has been made (e.g. exchanging components on the PCB boards, soldering work etc.).

### **3.2.4 Disposal**

- ▶ When decommissioning, please comply with local regulations regarding the disposal of electronic devices, such as the Electrical and Electronic Equipment Act.

## **4 Security**

To protect plants, systems, machines and networks against cyberthreats it is necessary to implement (and continuously maintain) an overall Industrial Security concept that is state of the art.

Carry out a risk assessment in accordance with VDI/VDE 2182 or IEC 62443-3-2 and plan the security measures with care.

If you have any questions about implementation, please contact technical support.

Report security gaps or security incidents in connection with a Pilz product to the Pilz Product Security Incident Response Team at <https://www.pilz.com/psirt>.

### **4.1 Security (remote I/O system PSS u2)**

Further information on Security can be found in the operating manuals of the relevant head modules.

### **4.2 Security (PSS u2 in the automation system PSS 4000)**

Further information on Security can be found in the system description PSS 4000 (1001467).

## 5 Function description

### 5.1 Block diagram

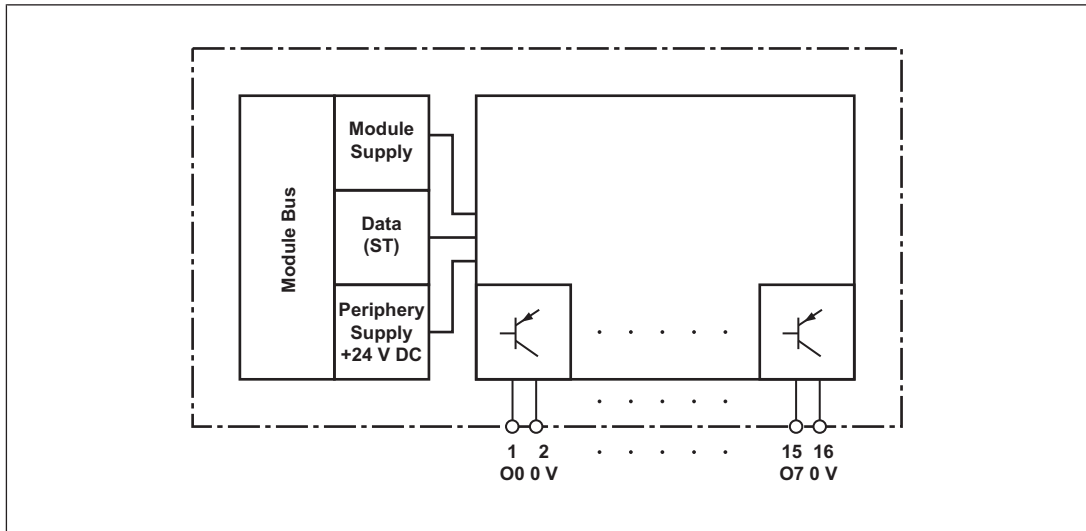

Fig.: Block diagram PSS u2 ES 8DOD (-R)

### 5.2 Supply

- ▶ The module is supplied with voltage via the head module/main voltage supply module PSS u2 PSx (-R) connected to the head module.
- ▶ The periphery supply provides the outputs with voltage

### 5.3 Outputs

Signals at the output

- ▶ "0" signal (0 V) at the output:
  - Output is high impedance
  - No current to the load
- ▶ "1" signal (+24 V) at the output:
  - Output is low impedance
  - Current is supplied to the load

Outputs

- ▶ The head module sets the output status via the module bus.

#### Use of the module: PSS u2 in the automation system PSS 4000

If the module does not receive a process image of outputs from the head module, the outputs of ST output modules are set to the value "0".

#### Use of the module: Remote I/O system PSS u2

If the module does not receive a process image of outputs from the head module, then substitute values are used for the process data. The value that is to be used as the substitute value can be configured.

Substitute values can be:

- ▶ Output switched off (default value)
- ▶ Output switched on
- ▶ Last valid value

## 5.4 Reaction times

Information on the reaction times is available in the operating manuals for the head modules or in the System Description PSS 4000.

## 5.5 Energy-saving functions

The energy-saving levels are controlled by the head module and are not configurable. The module supports the following energy-saving levels:

- ▶ Switching off the LEDs
  - The LEDs have two energy-saving levels:
    - Switching off the LEDs to display the terminal status
    - Switching off the LEDs to display the module and terminal status
- ▶ Switching off the terminals
  - The module switches off the voltage at the digital outputs.
- ▶ Standby mode
  - All module functions are inactive.
  - The LEDs for displaying the module and terminal status are switched off.

## 6 Structure of the process image Remote I/O (remote I/O system PSS u2)

When the electronic module is used in the remote I/O system, the data described below are available.

### ST-PIO

The module occupies 1 Byte in the process image of outputs.

Byte	Bit	Meaning	Status
0	0	Output data O0	0: "0"-signal (0 V) at the output: 1: "1"-signal (+24 V) at the output
	1	Output data O1	
	2	Output data O2	
	3	Output data O3	
	4	Output data O4	
	5	Output data O5	
	6	Output data O6	
	7	Output data O7	

### ST-PII

The module occupies 1 Byte in the process image of inputs.

Byte	Bit	Meaning	Status
1	0	Valid bit for output O0	0: Output error 1: The signal in the PIO corresponds to the output signal
	1	Valid bit for output O1	
	2	Valid bit for the output O2	
	3	Valid bit for output O3	
	4	Valid bit for output O4	
	5	Valid bit for output O5	
	6	Valid bit for output O6	
	7	Valid bit for output O7	

## 7 I/O data of the module (PSS u2 in the automation system PSS 4000)

When the electronic module for PSS u2 is used in the automation system PSS 4000, the data described below are available.

### 7.1 Available I/O data in the I/O mapping

Data access is via pre-defined I/O data types:

I/O data name (terminal)	I/O data type	Data element: Data type	Meaning	Status
O0(1)	ST_O_DO	Data: BOOL	Output data O0	0: "0"-signal (0 V) at the output: 1: "1"-signal (+24 V) at the output
O1(3)	ST_O_DO	Data: BOOL	Output data O1	
O2(5)	ST_O_DO	Data: BOOL	Output data O2	
O3(7)	ST_O_DO	Data: BOOL	Output data O3	
O4(9)	ST_O_DO	Data: BOOL	Output data O4	
O5(11)	ST_O_DO	Data: BOOL	Output data O5	
O6(13)	ST_O_DO	Data: BOOL	Output data O6	
O7(15)	ST_O_DO	Data: BOOL	Output data O7	
OutputValid_O0(1)	ST_I_DI	Data: BOOL	<i>OutputValid</i> bit for output O0	0: Output error 1: The signal in the PIO corresponds to the output signal
OutputValid_O1(3)	ST_I_DI	Data: BOOL	<i>OutputValid</i> bit for output O1	
OutputValid_O2(5)	ST_I_DI	Data: BOOL	<i>OutputValid</i> bit for output O2	
OutputValid_O3(7)	ST_I_DI	Data: BOOL	<i>OutputValid</i> bit for output O3	
OutputValid_O4(9)	ST_I_DI	Data: BOOL	<i>OutputValid</i> bit for output O4	
OutputValid_O5(11)	ST_I_DI	Data: BOOL	<i>OutputValid</i> bit for output O5	
OutputValid_O6(13)	ST_I_DI	Data: BOOL	<i>OutputValid</i> bit for output O6	
OutputValid_O7(15)	ST_I_DI	Data: BOOL	<i>OutputValid</i> bit for output O7	

### 7.2 Other I/O data

In addition to the I/O data available via I/O mapping, it is possible to access further I/O data in the user program:

- ▶ Valid bit of the bit *OutputValid\_O0*
- ▶ Valid bit of the bit *OutputValid\_O1*
- ▶ Valid bit of the bit *OutputValid\_O2*

- ▶ Valid bit of the bit *OutputValid\_O3*
- ▶ Valid bit of the bit *OutputValid\_O4*
- ▶ Valid bit of the bit *OutputValid\_O5*
- ▶ Valid bit of the bit *OutputValid\_O6*
- ▶ Valid bit of the bit *OutputValid\_O7*

In the Multi programming, access is via the PSS 4000 system control block "Valid".

In IEC 61131 programming, access is via the variable extension "WITH VALID".

## 8 Installation

### 8.1 General installation guidelines



#### NOTICE

R-type electronic modules may only be installed on R-type backplanes.



#### CAUTION!

##### Risk of material damage

The incorrect ambient temperature during assembly/dismantling can lead to material damage.

- Comply with the permitted ambient temperature for assembly/dismantling: -20°C ... +45°C



#### CAUTION!

##### Risk of material damage

Electrostatic discharge can damage components.

- Ensure against discharge before touching the product, e.g. by touching an earthed, conductive surface or by wearing an earthed arm-band.

## 8.1.1 Dimensions

The dimensions include the backplane, electronic module and terminal block.

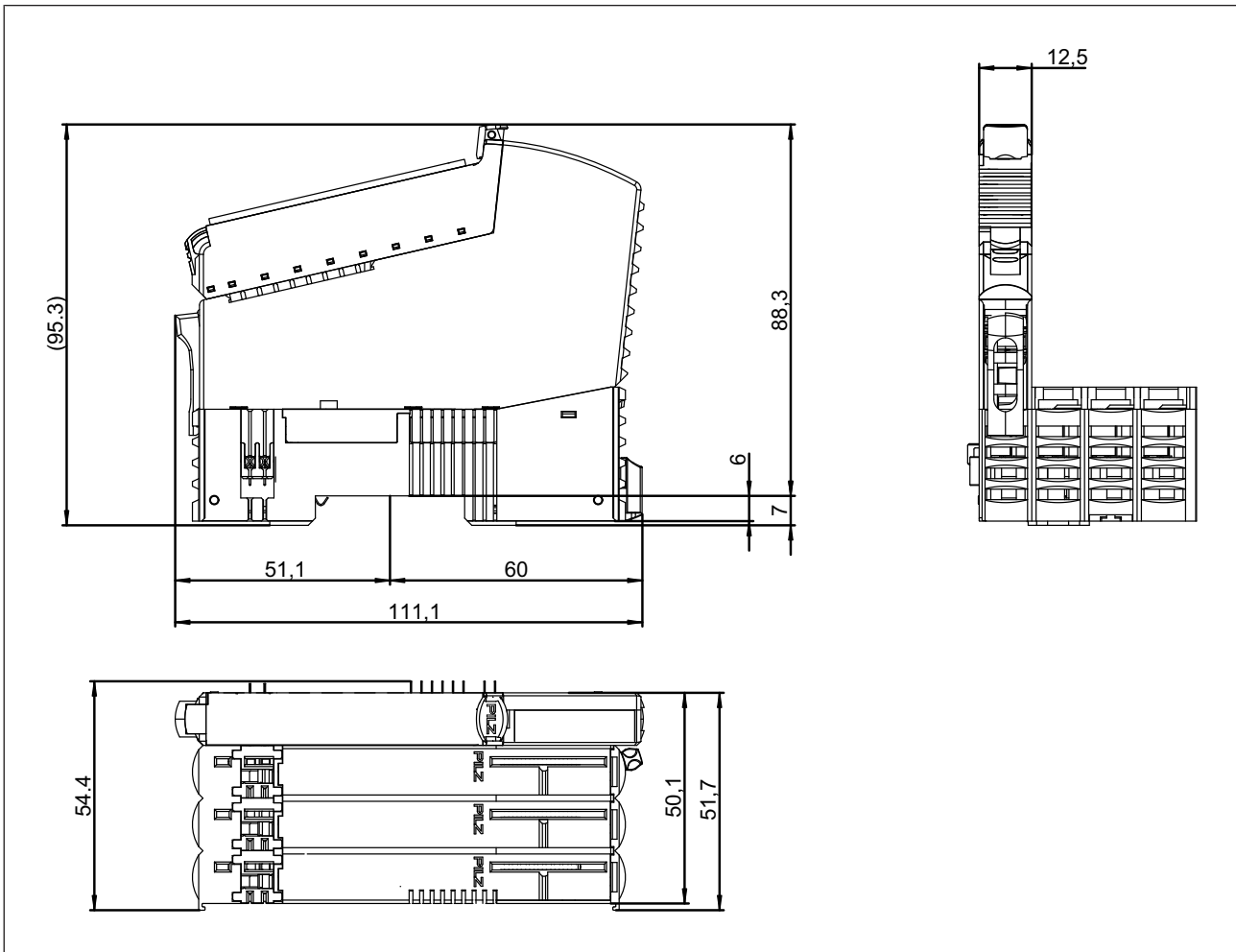

Fig.: Dimensions in mm, including backplane, electronic module and terminal block

## 8.2 Inserting and removing an electronic module

Please note:

- ▶ Backplane must be installed first.
- ▶ Electronic modules may only be plugged or unplugged if the terminal block has been removed first.
- ▶ The mechanics of the electronic modules are designed for 20 plug in/out cycles.

The following illustrations in chapters "Inserting an electronic module", "Removing an electronic module" and "Changing an electronic module during operation" are displayed as an example in the remote I/O system PSS u2 (see [Terminology \[5\]](#)).

## 8.2.1 Inserting an electronic module

1. Insert the electronic module into the suspension lug on the back-plane.

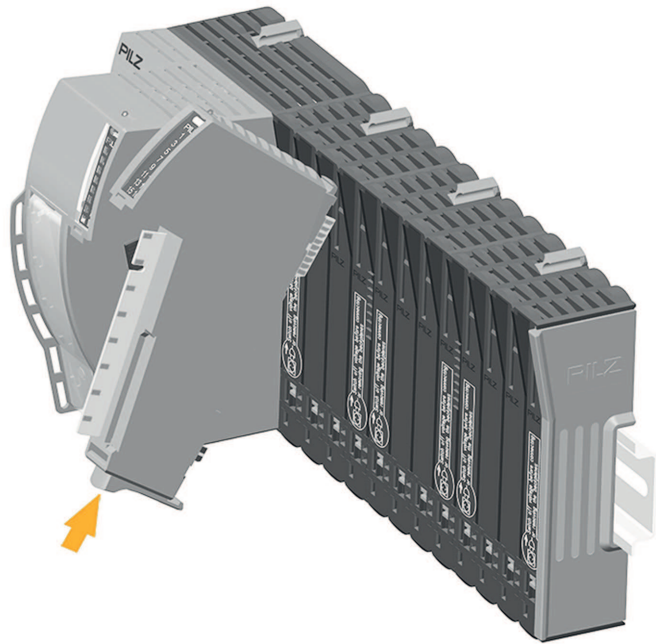

2. Swivel the electronic module downwards until you hear it click into place.

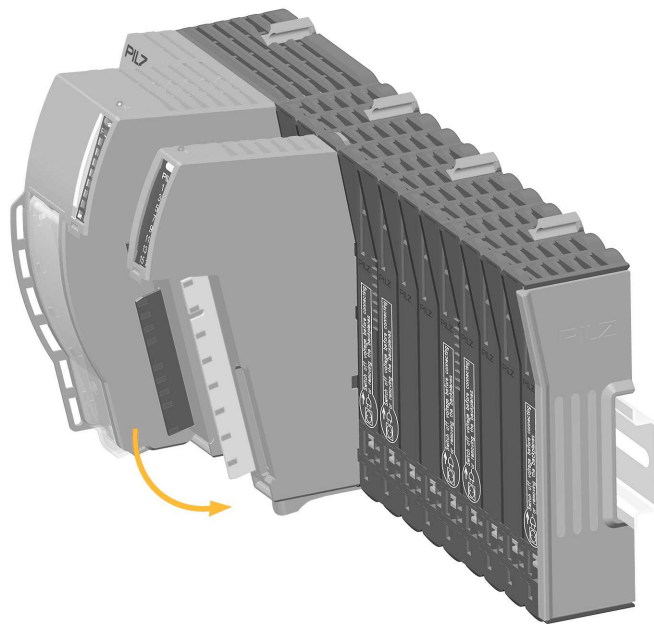

3. Insert the terminal block into the suspension lug on the module.

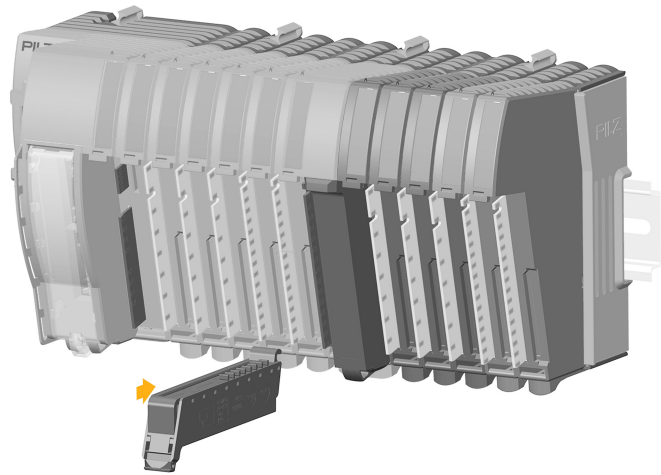

4. Swivel the terminal block upwards until you hear it click into place.

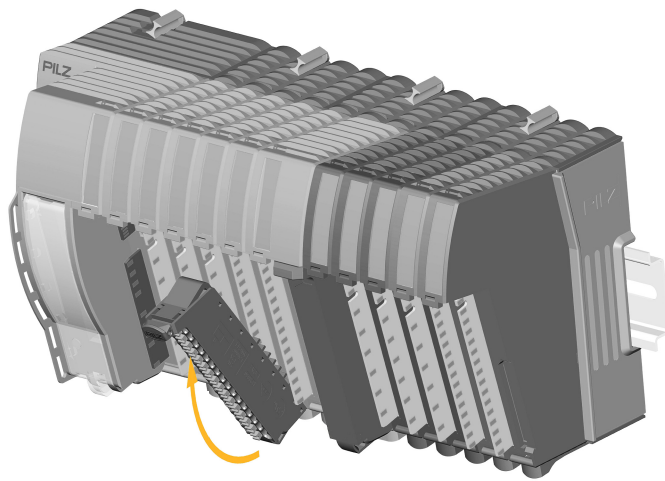

## 8.2.2 Removing an electronic module

1. Press the unlocking mechanism on the terminal block that is shown by the arrow and pull off the terminal block forward.

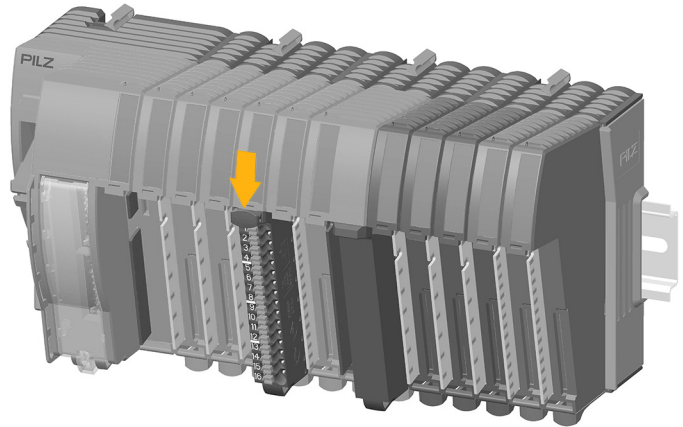

2. Press the unlocking mechanism that is shown by the arrow and pull off the electronic module upwards.

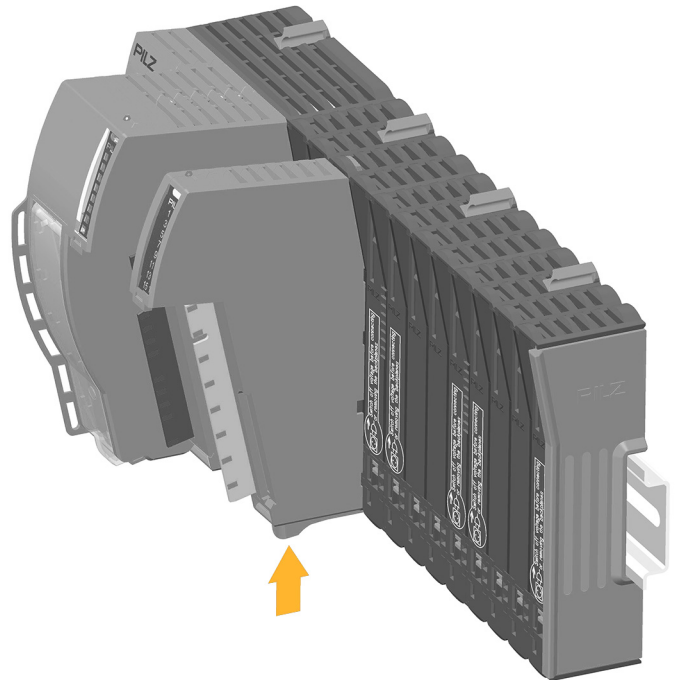

### 8.2.3 Changing an electronic module during operation

An electronic module can be hot swapped.

#### Effects

- ▶ Module bus communication between the other modules is not interrupted.
- ▶ The configuration data is retained (exchanging an electronic module with identical product ID).
- ▶ The module is detected automatically as soon as it is re-inserted.

#### Procedure

1. Removing an electronic module
2. Inserting an electronic module

A new electronic module can be inserted during operation.

#### Procedure (inserting an electronic module with a different product ID).

- ▶ Insert electronic module

#### Effects

- ▶ Module bus communication between the other modules is not interrupted.
- ▶ To detect the new module the following steps may be necessary:
  - Creating a new configuration or changing an existing configuration
  - Download of the configuration to the head module
  - Restart of the head module (supply voltage on/off) or warm reset via reset button.

## 9 Wiring

### 9.1 General wiring guidelines

Please note:

- ▶ The actuators may be connected using unshielded cables.
- ▶ The outputs do not need suppression for inductive loads.
- ▶ Use copper wiring.

#### 9.1.1 Connection mechanism for terminal blocks

Procedure:

- ▶ Use a flat head screwdriver.
- ▶ Strip the wire back 9 mm.
- ▶ Feed the stripped cable as far as it will go into the opening for the spring-loaded terminal.
- ▶ Check that the cable is firmly seated.

Please note:

- ▶ The minimum cable cross section for field connection terminals on the terminal blocks is 0.15 mm<sup>2</sup> (AWG26).
- ▶ The maximum cable cross section for field connection terminals on the terminal blocks is 1.5 mm<sup>2</sup> with ferrules (AWG14)
- ▶ Use copper wiring.

## 9.2 Terminal configuration

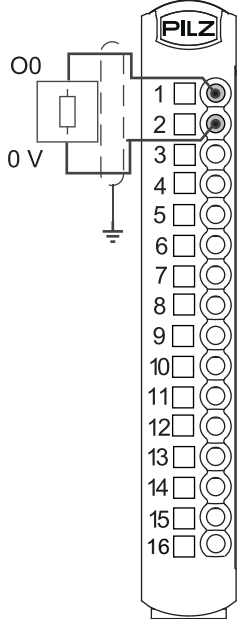
Terminal configuration	1-channel actuator
<p>1: Output O0                      2: 0 V periphery supply                      3: Output O1                      4: 0 V periphery supply                      5: Output O2                      6: 0 V periphery supply                      7: Output O3                      8: 0 V periphery supply                      9: Output O4                      10: 0 V periphery supply                      11: Output O5                      12: 0 V periphery supply                      13: Output O6                      14: 0 V periphery supply                      15: Output O7                      16: 0 V periphery supply</p>	

## 10 Operation

The status of the module is displayed via a red and a green LED. The status of the terminals is displayed via a green LED. If there is a module error, the module status display will light up red. The error will be signalled to the head module and will be entered in the head module's diagnostic log.

### 10.1 Display elements and messages

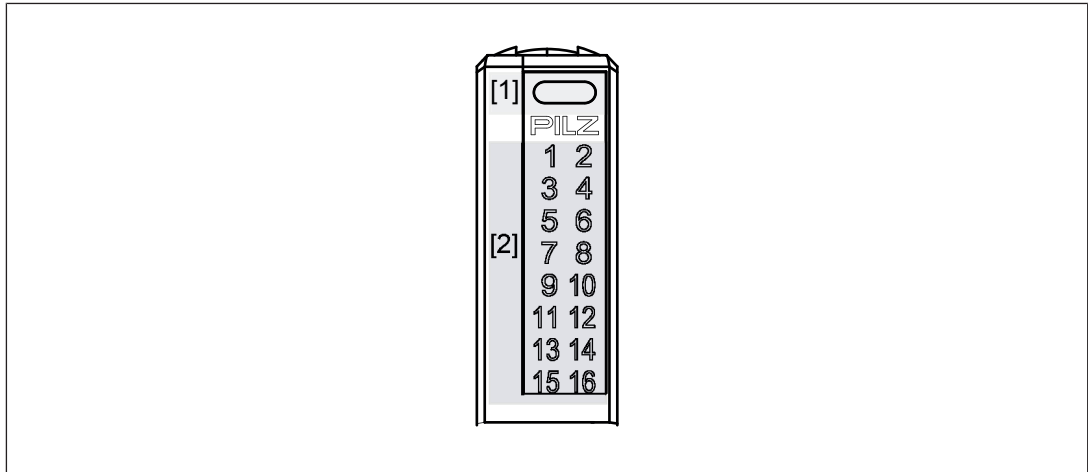







#### Legend

[1] Module status display

[2] Terminal status display

The module can detect the following errors:

[1]	Colour [1]	[2]	Colour [2]	Meaning	Further information
●	--	●	--	Module not ready for operation	
●	Green	●	--	Module ready for operation	
★	Green	★	Green	Module in operation and there is a "1"-signal at the output	
★	Green	●	--	Module in operation and there is a "0"-signal at the output	
●	Red	●	---	Configuration error Module was inserted in the wrong slot. Use of unreleased firmware	
★	Red	●	--	Internal errors	See module's diagnostic log

[1]	Colour [1]	[2]	Colour [2]	Meaning	Further information
	Red		Green	The module status display and the terminal status display on the relevant output flash synchronously Short circuit/overload/under-voltage	See module's diagnostic log
	Red		--	Temperature warning: too warm (1)	See module's diagnostic log
	Red		Green	The module status display and all terminal status displays flash synchronously Periphery supply is missing/ temperature error: too hot (1)	See module's diagnostic log

<sup>[1]</sup> There are two levels of overtemperature.

▶ Too warm:

If the module temperature exceeds a threshold value, then:

- a warning is sent to the head module.

If the temperature drops back below the threshold value, the module sends an all-clear.





▶ Too hot:

If the module temperature exceeds another threshold value, then:

- an error message is sent to the head module
- the outputs are switched off
- The valid bits for the outputs are set to "0"

After the "too hot" message has been received, if the temperature drops back below the "too warm" threshold value, the module will switch to an error-free state.

**Legend**

-  LED on
-  LED flashes
-  LED flashes
-  LED off

# 11 Technical details

Where standards are undated, the 2025-03 valid editions apply.

<b>General</b>	<b>328401</b>	<b>327401</b>
Certifications	<b>CE, UKCA, cULus Listed</b>	<b>CE, UKCA, cULus Listed</b>
Application range	<b>Standard</b>	<b>Standard</b>
Module's device code	<b>0016h</b>	<b>0x0C16</b>
<b>Electrical data</b>	<b>328401</b>	<b>327401</b>
Internal voltage supply (module supply)		
Module's power consumption	<b>0,16 W</b>	<b>0,16 W</b>
Periphery's voltage supply (periphery supply)		
Module's power consumption with no load	<b>0,3 W</b>	<b>0,3 W</b>
Max. power consumption of a positive-switching single-pole semiconductor output	<b>0,055 W</b>	<b>0,055 W</b>
Max. power dissipation of module	<b>0,9 W</b>	<b>0,9 W</b>
Permitted loads	<b>inductive, capacitive, resistive</b>	<b>inductive, capacitive, resistive</b>
<b>Process data remote IO system PSS u2</b>	<b>328401</b>	<b>327401</b>
Number of ST input bytes; if the assignment is incomplete, the assigned bits are stated in brackets	<b>1(8)</b>	<b>1(8)</b>
Number of ST output bytes; if the assignment is incomplete, the assigned bits are stated in brackets	<b>1(8)</b>	<b>1(8)</b>
<b>Semiconductor outputs</b>	<b>328401</b>	<b>327401</b>
Output	<b>00 ... 07</b>	<b>00 ... 07</b>
Number of positive-switching single-pole semiconductor outputs	<b>8</b>	<b>8</b>
Rated voltage	<b>24 V DC</b>	<b>24 V DC</b>
Typ. output current at "1" signal and rated voltage of semiconductor output	<b>0,5 A</b>	<b>0,5 A</b>
Permitted current range	<b>0,000 - 0,625 A</b>	<b>0,000 - 0,625 A</b>
Residual current at "0" signal	<b>0,001 mA</b>	<b>0,001 mA</b>
Max. transient pulsed current	<b>0,7 A</b>	<b>0,7 A</b>
Typ. threshold value for overload	<b>1,4 A</b>	<b>1,4 A</b>
Max. internal voltage drop	<b>70 mV</b>	<b>70 mV</b>
Max. processing time of semiconductor output when signal changes from "1" to "0"	<b>0,4 ms</b>	<b>0,4 ms</b>
Max. processing time of semiconductor output when signal changes from "0" to "1"	<b>0,42 ms</b>	<b>0,42 ms</b>

<b>Semiconductor outputs</b>		
	<b>328401</b>	<b>327401</b>
Potential isolation	Yes	Yes
Short circuit-proof	Yes	Yes
<b>Environmental data</b>		
	<b>328401</b>	<b>327401</b>
Application site		
in accordance with the standard	–	EN 50125-3
Application site	–	Minimum 1m distance from track
Climatic suitability	EN 60068-2-1, EN 60068-2-2, EN 60068-2-30, EN 60068-2-78, EN IEC 60068-2-14	EN 60068-2-1, EN 60068-2-2, EN 60068-2-30, EN 60068-2-78, EN IEC 60068-2-14
Ambient temperature		
Temperature range	-25 - 60 °C	-40 - 70 °C
in accordance with the standard	UL 61010	UL 61010
Max. temperature in accordance with UL	-25 - 60 °C	-40 - 60 °C
Storage temperature		
Temperature range	-40 - 70 °C	-40 - 70 °C
Climatic suitability		
in accordance with the standard	EN 60068-2-78	EN 60068-2-78
Humidity	95 % r. h. at 40 °C	95 % r. h. at 40 °C
Condensation during operation	Not permitted	EN 60068-2-30
Max. operating height above SL	5000 m	5000 m
EMC	EN 12015, EN 12016, EN 298, EN 50156-1, EN 61000-6-7, EN 61131-2 (Zone B), EN IEC 61000-6-2, EN IEC 61000-6-4	EN 12015, EN 12016, EN 298, EN 50121-4, EN 50156-1, EN 61000-6-7, EN 61131-2 (Zone B), EN IEC 61000-6-2, EN IEC 61000-6-4
Vibration		
in accordance with the standard	EN 60068-2-6	EN 60068-2-6
Frequency	8,4 - 150 Hz	8,4 - 150 Hz
Acceleration	10 m/s <sup>2</sup>	10 m/s <sup>2</sup>
Broadband noise		
in accordance with the standard	–	EN 60068-2-64
Frequency	–	5 - 2.000 Hz
Acceleration	–	2,3 m/s <sup>2</sup> eff.
Shock stress		
in accordance with the standard	EN 60068-2-27	EN 60068-2-27
Number of shocks	6	6
Acceleration	150 m/s <sup>2</sup>	150 m/s <sup>2</sup>
Duration	11 ms	11 ms
in accordance with the standard	EN 60068-2-27	EN 60068-2-27
Number of shocks	1000	1000
Acceleration	100 m/s <sup>2</sup>	100 m/s <sup>2</sup>
Duration	16 ms	16 ms

<b>Environmental data</b>	<b>328401</b>	<b>327401</b>
<b>Airgap creepage</b>		
in accordance with the standard	<b>EN 50156-1, EN 81-20</b>	<b>EN 50156-1, EN 81-20</b>
Overvoltage category	<b>III</b>	<b>III</b>
Pollution degree	<b>2</b>	<b>2</b>
in accordance with the standard	<b>EN 61131-2</b>	<b>EN 61131-2</b>
Overvoltage category	<b>II</b>	<b>II</b>
Pollution degree	<b>2</b>	<b>2</b>
in accordance with the standard	–	<b>EN 50124-1</b>
Overvoltage category	–	<b>OV2</b>
Pollution degree	–	<b>PD2</b>
<b>Protection type</b>		
in accordance with the standard	<b>EN 60529</b>	<b>EN 60529</b>
Housing	<b>IP20</b>	<b>IP20</b>
Terminals	<b>IP00</b>	<b>IP20</b>
<b>Potential isolation</b>	<b>328401</b>	<b>327401</b>
Potential isolation	<b>not evaluated by UL</b>	<b>not evaluated by UL</b>
Potential isolation between	<b>Semiconductor output and module supply</b>	<b>Semiconductor output and module supply</b>
Type of potential isolation	<b>Functional insulation</b>	<b>Functional insulation</b>
Rated surge voltage in operating heights up to max. 2000 m	<b>2500 V</b>	<b>2500 V</b>
Rated surge voltage in operating heights up to max. 5000 m	<b>2500 V</b>	<b>2500 V</b>
Potential isolation between	<b>Output and functional earth</b>	<b>Output and functional earth</b>
Type of potential isolation	<b>Functional insulation</b>	<b>Functional insulation</b>
Rated surge voltage in operating heights up to max. 2000 m	<b>2500 V</b>	<b>2500 V</b>
Rated surge voltage in operating heights up to max. 5000 m	<b>2500 V</b>	<b>2500 V</b>
<b>Mechanical data</b>	<b>328401</b>	<b>327401</b>
MTBF at 40 °C, 100 % duty cycle (8760 hours/year)	–	<b>286 Jahre</b>
<b>Material</b>		
Housing	<b>PC</b>	<b>PC</b>
Mounting type	<b>plug-in</b>	<b>plug-in</b>
<b>Dimensions</b>		
Height	<b>110,8 mm</b>	<b>110,8 mm</b>
Width	<b>12,5 mm</b>	<b>12,5 mm</b>
Depth	<b>72,5 mm</b>	<b>72,5 mm</b>
Weight	<b>33 g</b>	<b>35 g</b>

## 12 Supplementary data

### 12.1 Operating height

The values stated in the technical details apply to the use of the device in operating heights up to max. 2000 m above SL. When used at higher levels, restrictions of the max. ambient temperature (standard IEC 61131-2) must be taken into account.

Operating height above SL [m]	Multiplication factors for the devices' max. ambient temperature
0 ... 2000	1.0
3000	0.9
4000	0.8
5000	0.7

## 13 Order reference

### 13.1 Product

Product type	Features	Product ID
PSS u2 ES 8DOD 0.5A	PSS u2, electronic module for standard applications, 8 digital outputs, advanced diagnostics, terminal block PSS u2 T 16 required (not supplied with the system).	328401
PSS u2 ES 8DOD 0.5A -R	PSS u2, electronic module for standard applications, 8 digital outputs, advanced diagnostics, for increased environmental requirements and railway applications, terminal block PSS u2 T 16 required (not supplied with the system).	327401

### 13.2 Accessories

#### Terminal block

Product type	Features	Product ID
PSS u2 T 16 (1 pc.)	Terminal block 16-pin, scope of delivery: 1 piece	328850
PSS u2 T 16 (10 pcs.)	Terminal block 16-pin, scope of delivery: 10 pieces	328851
PSS u2 T 16 (5 x 10 pcs.)	Terminal block 16-pin, scope of delivery: 50 pieces	328852

#### Labelling bracket

Product type	Features	Product ID
PSS u2 A LC E1 (10 pcs.)	Label holder for electronic module 23.5 x 10.5 mm, scope of delivery: 10 pieces	328910
PSS u2 A LC E2 (10 pcs.)	Label holder for electronic module 103 x 10.5 mm, scope of delivery: 10 pieces	328911
PSS u2 A LA E1 (10 pcs.)	Labelling strips for electronic module 23.5 x 10.5 mm (10 x DIN A4 sheet)	328913
PSS u2 A LA E2 (10 pcs.)	Labelling strips for electronic module 103 x 10.5 mm (10 x DIN A4 sheet)	328914

#### Label holder for terminal block

Product type	Features	Product ID
PSS u2 A LC T3 (10 pcs.)	Label holder for terminal block 61 x 11.5 mm, scope of delivery: 10 pieces	328912

#### Coding elements

Product type	Features	Product ID
PSS u2 A CE E (10 pcs.)	Coding elements for electronic modules, scope of delivery: 10 pieces	328860

**Backplane**

<b>Product type</b>	<b>Features</b>	<b>Product ID</b>
PSS u2 B 1	PSS u2, accessories, backplane, for electronic modules, 1 slot, width 12.6 mm, height 107 mm, note the mounting distances	328811
PSS u2 B 4	PSS u2, accessories, backplane, for electronic modules, 4 slots, width 50.1 mm, height 107 mm, note the mounting distances	328810
PSS u2 B 1 -R	PSS u2, accessories, backplane, for electronic modules, 1 slot, for increased environmental requirements and railway applications, width 12.6 mm, height 107 mm, note the mounting distances	327811
PSS u2 B 4 -R	PSS u2, accessories, backplane, for electronic modules, 4 slots, for increased environmental requirements and railway applications, width 50.1 mm, height 107 mm, note the mounting distances	327810

## 14 EU/EC declaration of conformity

These products meet the requirements of the directive 2006/42/EC on machinery up to and including 19 January 2027, and the EU regulation 2023/1230 of the European Parliament and of the Council from 20 January 2027. The full EU and EC declaration of conformity is available to download at [www.pilz.com/manuals](http://www.pilz.com/manuals).

Authorised representative: Pilz GmbH & Co. KG, Felix-Wankel-Str. 2, 73760 Ostfildern, Germany

## 15 UKCA-Declaration of Conformity

These products comply with following UK legislation: Supply of Machinery (Safety) Regulation 2008.

The complete UKCA Declaration of Conformity is available on the Internet at [www.pilz.com/manuals](http://www.pilz.com/manuals).

Representative: Pilz Automation Technology, Pilz House, Little Colliers Field, Corby, Northamptonshire, NN18 8TJ United Kingdom, eMail: [mail@pilz.co.uk](mailto:mail@pilz.co.uk)

# Support

Technical support is available from Pilz round the clock.

## Americas

### Brazil

+55 11 97569-2804

### Canada

+1 888 315 7459

### Mexico

+52 55 5572 1300

### USA (toll-free)

+1 877-PILZUSA (745-9872)

## Asia

### China

+86 400-088-3566

### Japan

+81 45 471-2281

### South Korea

+82 31 778 3390

## Australia and Oceania

### Australia

+61 3 95600621

### New Zealand

+64 9 6345350

## Europe

### Austria

+43 1 7986263-444

### Belgium, Luxembourg

+32 9 3217570

### France

+33 3 88104003

### Germany

+49 711 3409-444

### Ireland

+353 21 4804983

### Italy, Malta

+39 0362 1826711

## Scandinavia

+45 74436332

## Spain

+34 938497433

## Switzerland

+41 62 88979-32

## The Netherlands

+31 347 320477

## Türkiye

+90 216 5775552

## United Kingdom

+44 1536 460866

## You can reach our international hotline on:

+49 711 3409-222

support@pilz.com

Pilz develops environmentally-friendly products using ecological materials and energy-saving technologies. Offices and production facilities are ecologically designed, environmentally-aware and energy-saving. So Pilz offers sustainability, plus the security of using energy-efficient products and environmentally-friendly solutions.



We are represented internationally. Please refer to our homepage [www.pilz.com](http://www.pilz.com) for further details or contact our headquarters.

Headquarters: Pilz GmbH & Co. KG, Felix-Wankel-Straße 2, 73760 Ostfildern, Germany  
Telephone: +49 711 3409-0, E-Mail: [info@pilz.com](mailto:info@pilz.com), Internet: [www.pilz.com](http://www.pilz.com)

**PILZ**  
THE SPIRIT OF SAFETY

CECE, CHRE, CMSE®, INDUSTRIAL Pi®, Leansafe®, Myze®, PAS4000®, PAScal®, PASconfig®, Pilz®, PIT®, PMCPirimo®, PMCProtego®, PMCTiende®, PMD®, PMi®, PNOZ®, Primo®, PSEN®, PSS®, PVIS®, SafetyBUS p®, SafetyNET p®, THE SPIRIT OF SAFETY® are registered and protected trademarks of Pilz GmbH & Co. KG in some countries. We would point out that product features may vary from the details stated in this document, depending on the status at the time of publication and the scope of the equipment. We accept no responsibility for the validity, accuracy and entirety of the text and graphics presented in this information. Please contact our Technical Support if you have any questions.

1003614-EN-05, 2025-04 Printed in Germany  
© Pilz GmbH & Co. KG, 2024