



▶ PSS u2 ES 4AI I (-R)

PILZ

THE SPIRIT OF SAFETY

Operating Manual-1005112-EN-05

- PSS u2 in the automation system PSS 4000
- Remote I/O system PSS u2



This document is the original document.

Where unavoidable, for reasons of readability, the masculine form has been selected when formulating this document. We do assure you that all persons are regarded without discrimination and on an equal basis.

All rights to this documentation are reserved by Pilz GmbH & Co. KG. Copies may be made for the user's internal purposes. Suggestions and comments for improving this documentation will be gratefully received.

CECE®, CHRE®, CMSE®, INDUSTRIAL PI®, Leansafe®, MYZEL®, PAS4000®, PAS-cal®, PASconfig®, Pilz®, PIT®, PMCprimo®, PMCprotego®, PM Ctendo®, PMD®, PMI®, PNOZ®, Primo®, PSEN®, PSS®, PVIS®, SafetyBUS p®, SafetyEYE®, SafetyNET p®, THE SPIRIT OF SAFETY® are registered and protected trademarks of Pilz GmbH & Co. KG in some countries.



SD means Secure Digital

1	Introduction	5
1.1	Validity of documentation	5
1.2	Using the documentation	5
1.3	Terminology	5
1.4	Definition of symbols	6
2	Overview	7
2.1	Module features	7
2.2	Side view right-hand	8
3	Safety	9
3.1	Intended use	9
3.1.1	Third-party manufacturer licence information	11
3.2	Safety regulations	11
3.2.1	Additional documents that apply	11
3.2.2	Use of qualified personnel	11
3.2.3	Warranty and liability	12
3.2.4	Disposal	12
4	Security	13
4.1	Security (remote I/O system PSS u2)	13
4.2	Security (PSS u2 in the automation system PSS 4000)	13
5	Function description	14
5.1	Block diagram	14
5.2	Supply	14
5.3	Signal processing	15
5.4	Measuring range	16
5.5	Working range monitoring	17
5.6	Moving average	19
5.7	Scaling	20
5.8	Range monitoring	23
5.9	Threshold value monitoring	24
5.10	Data format	25
5.11	Summary of configuration options	27
5.12	Reaction times	28
5.13	Energy-saving functions	29
6	Structure of the process image (Remote I/O system PSS u2)	30
7	I/O data of the module (PSS u2 in the automation system PSS 4000)	34
7.1	Available I/O data in the I/O mapping	34
7.2	Other I/O data	35
8	Installation	36
8.1	General installation guidelines	36
8.1.1	Dimensions	37
8.2	Inserting and removing an electronic module	37

8.2.1	Inserting an electronic module	38
8.2.2	Removing an electronic module.....	40
8.2.3	Changing an electronic module during operation	41
9	Wiring	42
9.1	General wiring guidelines.....	42
9.2	Terminal configuration.....	42
9.2.1	Connection examples.....	43
10	Operation	45
10.1	Display elements and messages	45
11	Technical details	48
12	Supplementary data	52
12.1	Operating height.....	52
13	Order reference	53
13.1	Product.....	53
13.2	Accessories.....	53
14	EU/EC declaration of conformity	55
15	UKCA-Declaration of Conformity	56

1 Introduction

1.1 Validity of documentation

This operating manual explains the function and operation, describes the installation and provides guidelines on how to connect the product.

This documentation is valid for the product PSS u2 ES 4AI I from Version HW 1.1, FW 1.4. It is valid until new documentation is published.

This documentation is valid for the product PSS u2 ES 4AI I -R from Version HW 1.1, FW 1.4. It is valid until new documentation is published.

1.2 Using the documentation

This document is intended for instruction. Only install and commission the product if you have read and understood this document. The document should be retained for future reference.

Please refer to the PSS u2 Installation Manual.

1.3 Terminology

PSS u2 system

A PSS u2 system consists of a PSS u2 head module, main voltage supply module and optional PSS u2 electronic modules with backplanes.

Remote I/O system PSS u2

PSS u2 system without control functionality that provides I/Os. The I/Os can be controlled via a fieldbus.

The configuration is performed in the tool PASconfig.

PSS u2 in the automation system PSS 4000

A PSS u2 system can be used in the automation system PSS 4000. A PSS u2 system is a 2nd generation device in the automation system PSS 4000.

The configuration is performed in the tool PAS4000.

Basic type

The basic versions of PSS u2 modules are called base type modules (e.g. PSS u2 EF 8DI).

R-type

PSS u2 modules that are suitable for use with increased environmental requirements and railway applications are called R-type modules (e.g. PSS u2 EF 8DI -R).

1.4 Definition of symbols

Information that is particularly important is identified as follows:



DANGER!

This warning must be heeded! It warns of a hazardous situation that poses an immediate threat of serious injury and death and indicates preventive measures that can be taken.



WARNING!

This warning must be heeded! It warns of a hazardous situation that could lead to serious injury and death and indicates preventive measures that can be taken.



CAUTION!

This refers to a hazard that can lead to a less serious or minor injury plus material damage, and also provides information on preventive measures that can be taken.



NOTICE

This describes a situation in which the product or devices could be damaged and also provides information on preventive measures that can be taken. It also highlights areas within the text that are of particular importance.



INFORMATION

This gives advice on applications and provides information on special features.

2 Overview

Module structure:

A module consists of

- ▶ an electronic module,
- ▶ a terminal block with cage clamp terminals and
- ▶ a module carrier





The electronic modules are plugged into the backplane and determine the function. The backplane is used for communication between the head module and the electronic modules and forms the carrier unit for the electronic modules. The terminal block is plugged into the electronic modules and is used to connect the field wiring.

Details of the terminal blocks that can be used are available under "Intended Use".

2.1 Module features

Application of the product PSS u2 ES 4AI I (-R):

Electronic module with analogue inputs for standard applications

- ▶ 4 analogue inputs for current measurement
- ▶ Each input can be configured separately
- ▶ Resolution: 15 bit
- ▶ Current limitation per input
- ▶ Measuring range 0 ... 25.6 mA
- ▶ Data format  25]
 - 16 bit two's complement
 - 15 bit sign and magnitude representation + sign bit (MSB)
(can only be configured in the remote I/O system PSS u2)
- ▶ Scaling
- ▶ Moving average
- ▶ Working range monitoring  17]
- ▶ Range monitoring  23]
- ▶ Threshold value monitoring  24]
- ▶ LEDs  45] for:
 - Operating status per input
 - Module error



INFORMATION

HART communication

Due to the module's high cutoff frequency of 700 Hz, the HART protocol cannot be filtered completely by the input filter.

- ▶ **R-type:**
for increased environmental requirements and railway applications

2.2 Side view right-hand

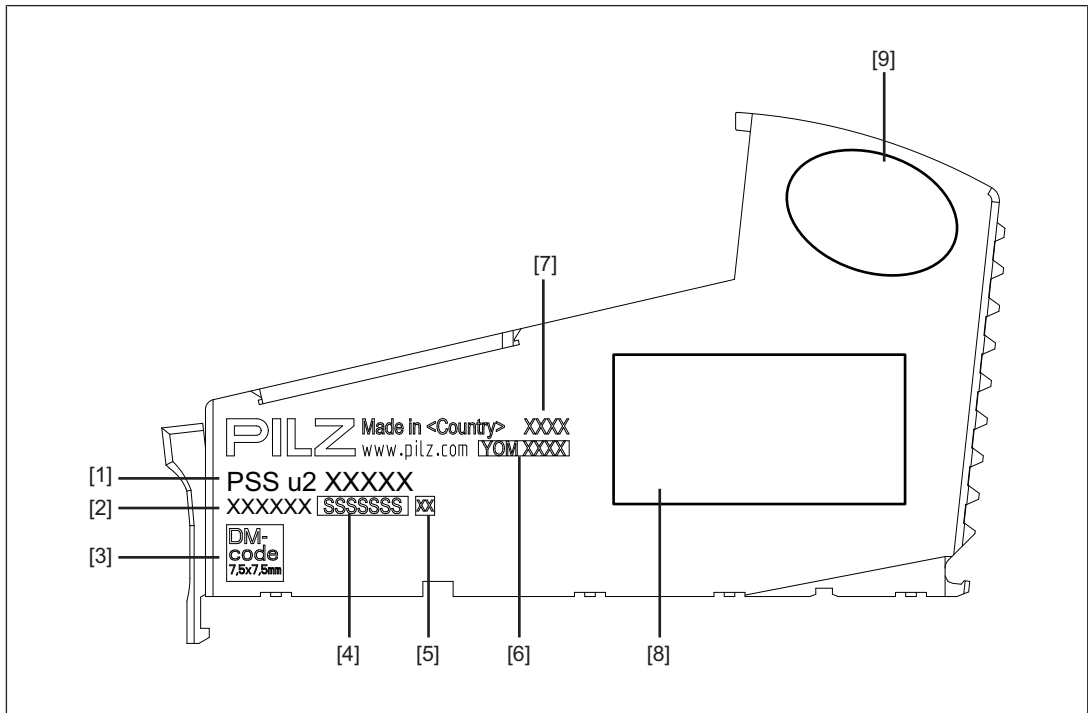

Fig.: Electronic module without terminal block, side view

Legend

[1]	Product Name
[2]	Order number
[3]	2D code product information
[4]	Serial number
[5]	Hardware version
[6]	"YOM" year of manufacture
[7]	Production site
[8]	Placeholder for block diagram
[9]	Placeholder for approval tags

3 Safety

3.1 Intended use



INFORMATION

If the module name is not explicitly named, the details apply to all the variants of the module.

Use in a PSS u2 system

The module PSS u2 ES 4AI I may be used in the following PSS u2 systems (see [Terminology](#) [ 5]):

- ▶ Remote I/O system PSS u2
- ▶ PSS u2 in the automation system PSS 4000 (generation 2)

The module PSS u2 ES 4AI I -R may be used in the following PSS u2 system (see [Terminology](#) [ 5]):

- ▶ PSS u2 in the automation system PSS 4000 (2nd generation)

The module/backplane/safety controller should be installed in a protected environment, see documents:

- ▶ Installation Manual PSS u2 in the automation system PSS 4000 (1006253), under "Installation in a protected space"
- ▶ Installation Manual Remote I/O system PSS u2 (1004152), under "Installation in a protected space"

Make sure that only authorised personnel have access to the products.



Standard applications

The module may be used for standard applications.

Analogue inputs

The module provides analogue inputs.

Application areas

- ▶ Use on machinery and in an industrial environment (2006/42/EC and EU 2023/1230)
The modules PSS u2 ES 4AI I (-R) can be used for **non-safety-related** applications (see [Technical details](#) [ 48]).
- ▶ Use in railway applications (CENELEC)
Depending on the selected railway architecture (see Safety Manual, under Safety architectures for railway applications (1006614)), the module PSS u2 ES 4AI I -R meets the requirements of EN 50126, EN 50129, EN 50159, EN 50716 and EN 45545, safety category SIL 0 (basic integrity), (see [Technical details](#) [ 48]).
Only R-type modules may be used in a PSS u2 system for railway applications.

► Increased environmental requirements

The module PSS u2 ES 4AI I -R is suitable for use where there are increased environmental requirements (see [Technical details \[📖 48\]](#)).

Only R-type modules may be used in a PSS u2 system in applications with increased environmental requirements.

Operating height

With reference to the standard IEC 61131-2 the values stated in the technical details for ambient temperature are reduced at heights >2000 m operating height above sea level (see [Supplementary data \[📖 52\]](#)).

EMC-compliant installation

Intended use includes making the electrical installation EMC-compliant. Please refer to the guidelines stated in the relevant installation manuals (see [Additional documents that apply \[📖 11\]](#)).

Improper use

The following is deemed improper use in particular

- Any component, technical or electrical modification to the module,
- Use of the module outside the areas described in this operating manual,
- Any use of the module that is not in accordance with the technical details.

Software tools

The module PSS u2 ES 4AI I is supported by:

- PASconfig from Version 1.0.0
- PAS4000 from Version 1.29.0

The module PSS u2 ES 4AI I -R is supported by:

- PAS4000 from Version 1.29.0



INFORMATION

We recommend that you always use the latest version of the software tool (download from www.pilz.com).

Backplane

The module PSS u2 ES 4AI I may be installed on the following backplanes:

- PSS u2 B 1
- PSS u2 B 4

The module PSS u2 ES 4AI I -R may be installed on the following backplanes:

- PSS u2 B 1 -R
- PSS u2 B 4 -R

Terminal blocks

The module may be used in conjunction with the following terminal block:

- ▶ 16-pin terminal block

3.1.1 Third-party manufacturer licence information

The product contains open source software, whose terms of use could further limit the product's application area. It is essential that you observe the third-party manufacturer licence information.

Further information is available in the document "Third-party manufacturer licence information PSS u2 ES 4AI U (-R)/PSS u2 ES 4AI I (-R)" (document number 1007367) at www.pilz.com.

3.2 Safety regulations

3.2.1 Additional documents that apply

Please read and take note of the following documents:

- ▶ Installation Manual remote I/O system PSS u2 (1004152)
- ▶ Installation Manual PSS u2 in the automation system PSS 4000 (1006253)
- ▶ System Description PSS 4000 (1001467)
- ▶ Safety Manual PSS 4000 (1001468)

With railway applications you should also refer to:

- ▶ Safety Manual, Safety Architectures for Railway Applications (1006614)

You will need to be conversant with the information in these documents in order to fully understand this operating manual.

3.2.2 Use of qualified personnel

The products may only be assembled, installed, programmed, commissioned, operated, de-commissioned and maintained by persons who are competent to do so.

A competent person is a qualified and knowledgeable person who, because of their training, experience and current professional activity, has the specialist knowledge required. In order to inspect, assess and handle products, devices, systems, plant and machinery, this person must be familiar with the state of the art and the applicable national, European and international laws, directives and standards.

It is the company's responsibility only to employ personnel who

- ▶ Are familiar with the basic regulations concerning health and safety / accident prevention,
- ▶ Have read and understood the information provided in the section entitled Safety
- ▶ Have a good knowledge of the generic and specialist standards applicable to the specific application.

3.2.3 Warranty and liability

All claims to warranty and liability will be rendered invalid if

- ▶ The product was used contrary to the purpose for which it is intended,
- ▶ Damage can be attributed to not having followed the guidelines in the manual,
- ▶ Operating personnel are not suitably qualified,
- ▶ Any type of modification has been made (e.g. exchanging components on the PCB boards, soldering work etc.).

3.2.4 Disposal

- ▶ When decommissioning, please comply with local regulations regarding the disposal of electronic devices, such as the Electrical and Electronic Equipment Act.

4 Security

To protect plants, systems, machines and networks against cyberthreats it is necessary to implement (and continuously maintain) an overall Industrial Security concept that is state of the art.

Carry out a risk assessment in accordance with VDI/VDE 2182 or IEC 62443-3-2 and plan the security measures with care.

If you have any questions about implementation, please contact technical support.

Report security gaps or security incidents in connection with a Pilz product to the Pilz Product Security Incident Response Team at <https://www.pilz.com/psirt>.

4.1 Security (remote I/O system PSS u2)

Further information on Security can be found in the operating manuals of the relevant head modules.

4.2 Security (PSS u2 in the automation system PSS 4000)

Further information on Security can be found in the system description PSS 4000 (1001467).

5 Function description

5.1 Block diagram

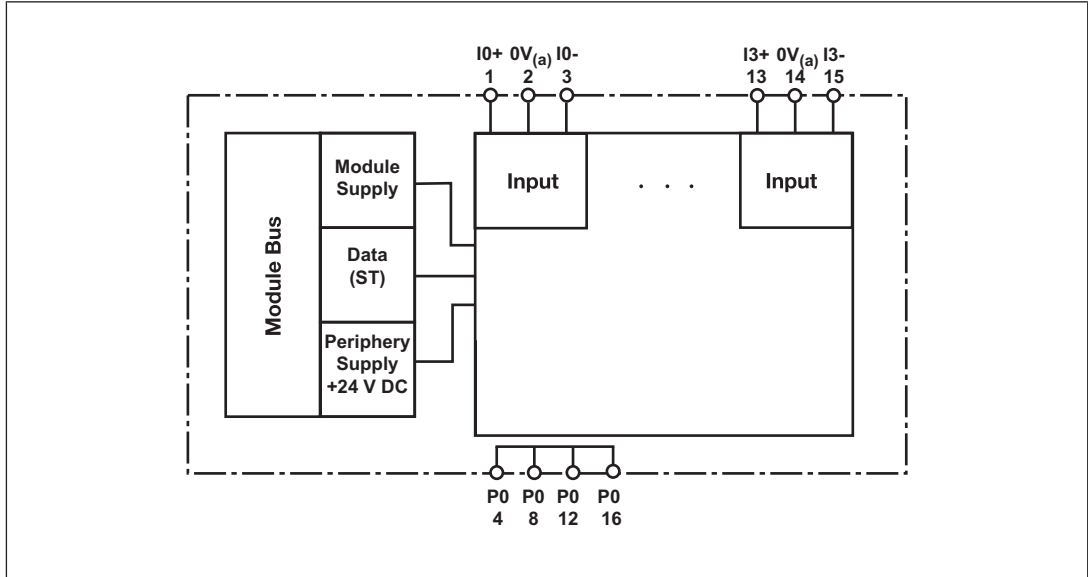

Fig.: Block diagram PSS u2 ES 4AI I (-R)

5.2 Supply

- ▶ The module is supplied with voltage via the head module/main voltage supply module PSS u2 PSx (-R) connected to the head module.

5.3 Signal processing

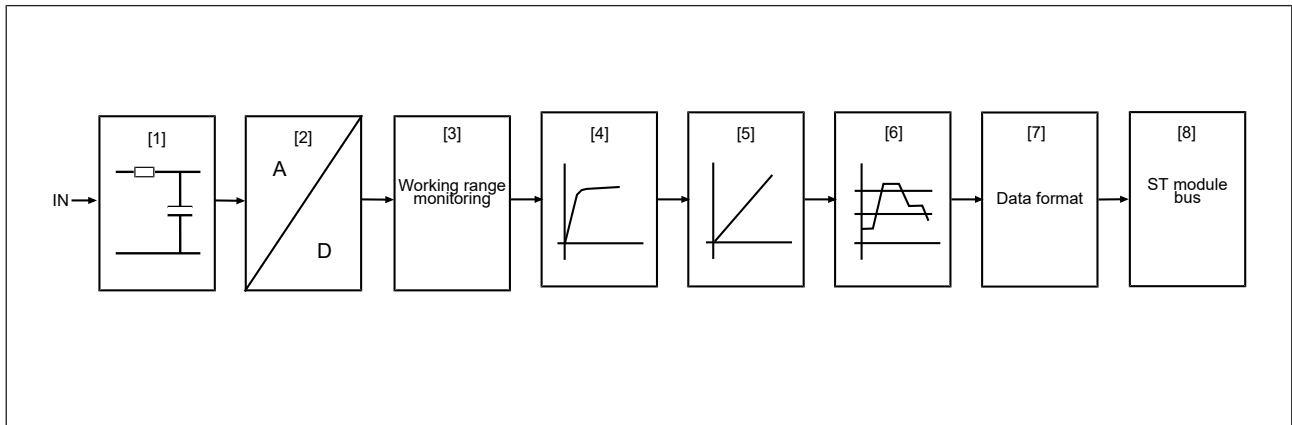

Fig.: Schematic representation of signal processing

- ▶ [1] Input filter
The analogue signal is pre-filtered.
- ▶ [2] A/D converter
The analogue value is read in and converted into digital signals with a 15 bit resolution (32 767 steps).
- ▶ [3] Working range monitoring
Working range monitoring can be activated for the digital signal in order to detect wiring faults.
- ▶ [4] Moving averaging
A digital filter can be activated for the digitalised measured value.
- ▶ [5] Scaling
The digitalised measured value can be scaled to a 16 bit value.
- ▶ [6] Area and threshold value monitoring
The scaled digital value can be monitored to check if ranges and threshold values have been exceeded.
- ▶ [7] Data format
The data format enables the scaled digital value to be represented as a two's complement or as sign and magnitude (only in the remote I/O system PSS u2).
- ▶ [8] ST module bus
The scaled digital value is transmitted to the head module via the ST module bus. As an option the input module can send status information for each input. All the configuration data is stored in the head module and is assigned to the input module on restart. This way the configuration data is retained even if you change the input module.

5.4 Measuring range

The module has a measuring range of 0 ... 25.6 mA. The module is suitable for connecting sensors with a current output that lies inside the measuring range.

If the value moves outside the measuring range, the valid bit of the corresponding input in the user program is set to 0 and an error message is issued.

► Use in the PSS u2 automation system PSS 4000

The measured positive or negative maximum value is set to zero.

► Use in the remote I/O system PSS u2

The measured positive or negative maximum value will continue to be registered in the user program as the scaled digital value.

Negative measured values up to - 0.1 mA (-128₀) are tolerated so that an error message is not issued for unwired terminals.

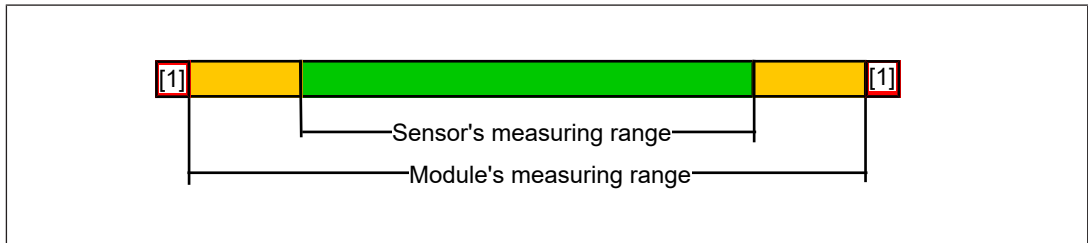

Fig.: Relationship between the module's measuring range and the sensor's measuring range

Legend

- [1] Module's measuring range exceeded
Valid bit = 0

5.5 Working range monitoring

The limits of the working range (valid measuring range) are configurable.

If you monitor the input value you can define a working range that is used to detect sensor faults or faults in the wiring, such as open circuit or short circuit. Monitoring works with the digitalised value before it is scaled. An error message is issued if the value moves outside the limit values. The fact that the values move outside the limit values will also be registered in the user program.

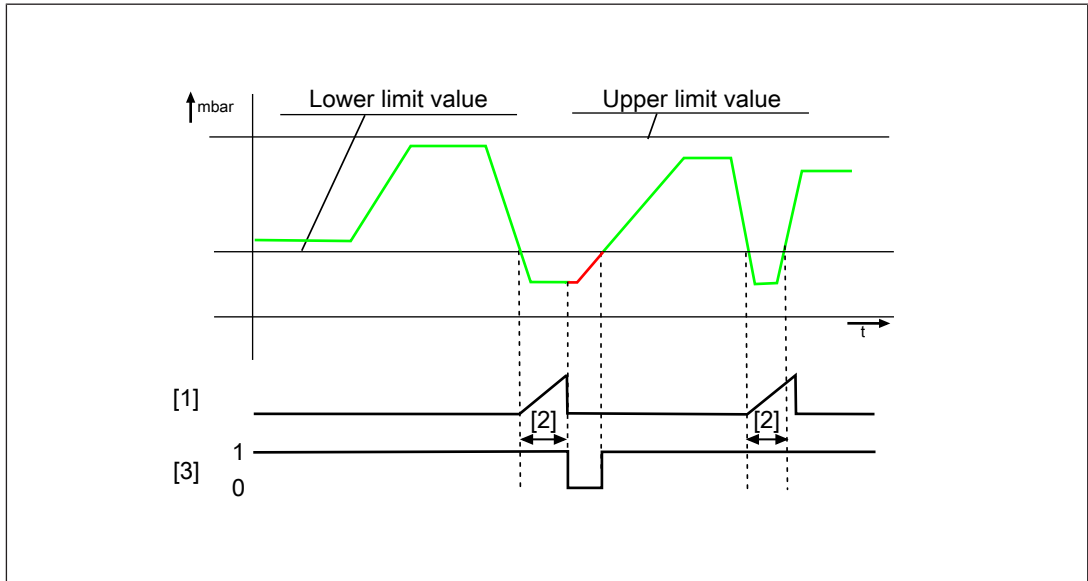

Fig.: Example of values moving outside the lower limit value

Legend

- [1] Configurable time for which values outside the limit values will be tolerated.
- [2] tolerated configured time
- [3] The fact that the values moved outside the limit values is registered in the user program.

Monitoring in accordance with NAMUR NE43

We recommend that you configure the limit values for which values outside the limit values will be tolerated, in accordance with NAMUR NE43.

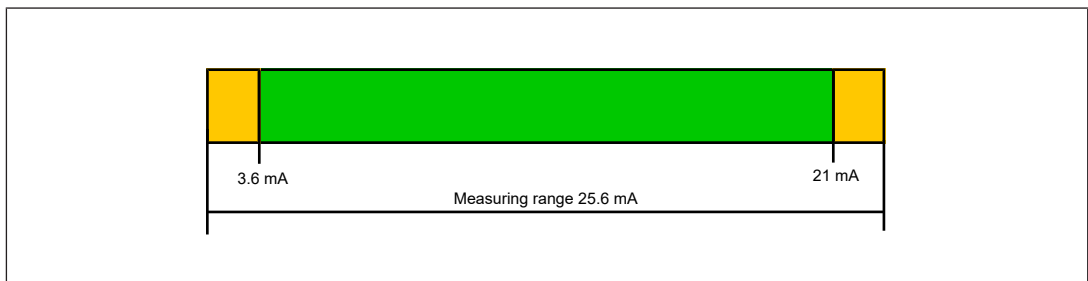

Fig.: Limit values in accordance with NAMUR NE43

If working range monitoring is activated, the following default values apply:

- ▶ **Lower limit value:** 4608_D (3.6 mA)
(e.g. open circuit)

- ▶ **Upper limit value:** 26880_D (21 mA)
(e.g. short circuit or transducer error)
- ▶ Period for which an overshoot and undershoot will be tolerated: 1 ms

The default settings are in accordance with NAMUR NE 43 recommendation to simplify the signal level for the failure information. We recommend compliance with NAMUR recommendation NE 43.



WARNING!

Potential loss of safety function if the working range monitoring is not used

It must be ensured that open circuits and sensor errors are detected. If you do not use working range monitoring, other suitable measures must be taken.

5.6 Moving average

A digital filter can suppress interference frequencies in the input signals. The filter is implemented by forming the moving average. When forming the moving average, the sum of the latest sampled results is used to calculate an average. The module has a cycle time of 0.1 ms. With a cycle time of 0.1 ms, the input signal is sampled with a frequency of 10 kHz. The number of sampled results and the period over which the average is calculated is configurable in the following steps:

- ▶ 0.1 ms (no filtering)
- ▶ 0.2 ms
- ▶ 0.5 ms
- ▶ Default setting 1 ms
- ▶ 2 ms
- ▶ 5 ms
- ▶ 10 ms
- ▶ 17 ms, for 60 Hz interference attenuation
- ▶ 20 ms, for 50 Hz interference attenuation

Special features and examples:

- ▶ 0.1 ms
There is no filtering. The result corresponds to the sampled value.
- ▶ 0.2 ms
The moving average is calculated over 2 cycle times.
- ▶ 0.5 ms
The moving average is calculated over 5 cycle times.
- ▶ 1 ms
The prefilter is active (see section entitled "Operating principle of the prefilter"). The prefilter supplies an average as the result of averaging over 10 cycle times. No additional moving average is formed (division by 1).
- ▶ 2 ms
The prefilter is active (see section entitled "Operating principle of the prefilter"). The moving average for the filter is calculated from 2 averages from the prefilter.
- ▶ 5 ms
The prefilter is active (see section entitled "Operating principle of the prefilter"). The moving average for the filter is calculated from 5 averages from the prefilter.
- ▶ 10 ms
The prefilter is active (see section entitled "Operating principle of the prefilter"). The moving average for the filter is calculated from 10 averages from the prefilter.
- ▶ 17 ms
The prefilter is active (see section entitled "Operating principle of the prefilter"). The moving average for the filter is calculated from 17 averages from the prefilter.
This setting includes interference frequency suppression of 60 Hz.

▶ 20 ms

The prefilter is active (see section entitled "Operating principle of the prefilter"). The moving average for the filter is calculated from 20 averages from the prefilter.

This setting includes interference frequency suppression of 50 Hz.

Operating principle of the prefilter

- ▶ The prefilter is activated from a filter setting ≥ 1 ms. The prefilter cycle time is 1 ms. The prefilter records 10 measured values in the space of one module cycle time of 0.1 ms. Of these 10 measured values, the largest and the smallest recorded measured values are rejected and an average is calculated from the remaining 8 values. The prefilter supplies a new value every 1 ms.



INFORMATION

A filter always results in attenuation and a delay of the (input) signal.

5.7

Scaling

The scaling function can be used to convert the digitalised measured value (Input) into a scaled digital value (ScaledValue). The digitalised measured value (Input) corresponds to the filtered value (see Signal processing). The scaled digital value is represented with a 16 bit resolution (-32768D...32767D) and is registered in the process image (see Structure of the process image). The default values are selected to give a scaling with gradient **m** of 1 and an offset (y axis intercept) of 0.

Scaling can only be used with linear input variables.

- ▶ The digitalised measured value (Input) is scaled over a two-point characteristic.
- ▶ The two points are configured as follows:
- Lower limit value of the measuring range (MeasuringLow): Point 1 on the X-axis
 - Upper limit value of the measuring range (MeasuringHigh): Point 2 on the X-axis
 - Lower limit value of the scaled range (ScaledLow): Point 1 on the Y-axis
 - Upper limit value of the scaled range (ScaledHigh): Point 2 on the Y-axis
 - In order not to limit the measuring range, we recommend you select two end points on a straight line, which include the whole measuring range to be scaled.
- ▶ Error reactions:
- If MeasuringLow = MeasuringHigh, then the calculation of the scaled digital value will result in a division by zero. The terminal LEDs belonging to the input flash green and the status LED flashes red. The input valid bits are set to "0" and a diagnostic message is entered in the error stack. The scaled value (ScaledValue) is set to "0".
 - If MeasuringLow < MeasuringHigh and Input < MeasuringLow, then ScaledValue = ScaledLow
 - If MeasuringLow < MeasuringHigh and Input > MeasuringHigh, then ScaledValue = ScaledHigh

- If MeasuringLow > MeasuringHigh and Input > MeasuringLow, then ScaledValue = ScaledLow
- If MeasuringLow > MeasuringHigh and Input < MeasuringHigh, then ScaledValue = ScaledHigh
- If the digitalised measured value (input) leaves the configured measuring range, there is no error message and the LEDs do not flash.

Exceeding the configured measuring range is signalled in the process image (PII) (e.g. via a special status bit).

The value ScaledLow or ScaledHigh is transmitted to the head module, depending on whether the upper or lower limit has been exceeded.

The LEDs on the module status display and the terminal status display remain green, as there is no error.

Calculating the scaled digital value (ScaledValue) from the digitalised measured value (Input):

$$\text{ScaledValue} = \text{ScaledLow} + [((\text{Input} - \text{MeasuringLow}) * (\text{ScaledHigh} - \text{ScaledLow})) / (\text{MeasuringHigh} - \text{MeasuringLow})]$$

- ▶ The value ScaledValue is available as a scaled digital value in the user program.

Example:

In this example, a pressure of 0 to 10,000 mbar is monitored.

MeasuringLow	Lower limit value of the measuring range	4608D
MeasuringHigh	Upper limit value of the measuring range	26 880D
ScaledLow	Lower limit value of the scaled range	0 bar
ScaledHigh	Upper limit value of the scaled range	10 000 mbar
Input	Value to be scaled	12 800D

▶ **Scaled digital value:**

$$\text{ScaledValue} = \text{ScaledLow} + [((\text{Input} - \text{MeasuringLow}) * (\text{ScaledHigh} - \text{ScaledLow})) / (\text{MeasuringHigh} - \text{MeasuringLow})] = 0 + [((12800D - 4608D) * (10 000 - 0)) / (26 880D - 4608D)] = 3679D$$

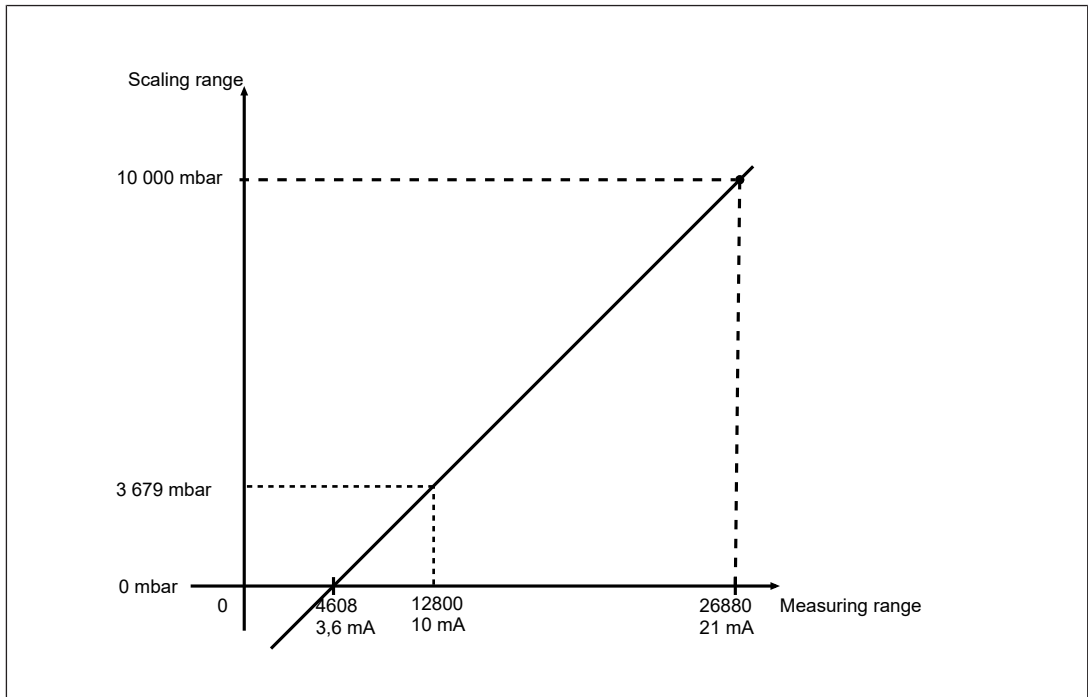

Fig.: Scaling

Legend

- Scaling range
- Scaled values
- Measuring range
- Measured current values



INFORMATION

Scaling may influence the accuracy of the digitalised measured value.

5.8 Range monitoring

Range monitoring works with the scaled digital value. Up to 4 individually configurable ranges can be monitored per input. Range monitoring compares the upper and lower limit value for each configured range with the digital value after scaling and registers the result of the comparison in the user program. If a value moves outside a range, the measured scaled digital value will continue to be registered in the process image.

The result is "1" when the following condition is met:

- Configured lower limit value \leq Scaled digital value \leq Configured upper limit value

If the scaled digital value is outside a range's lower or upper limit value, then the result for this range will be "0".

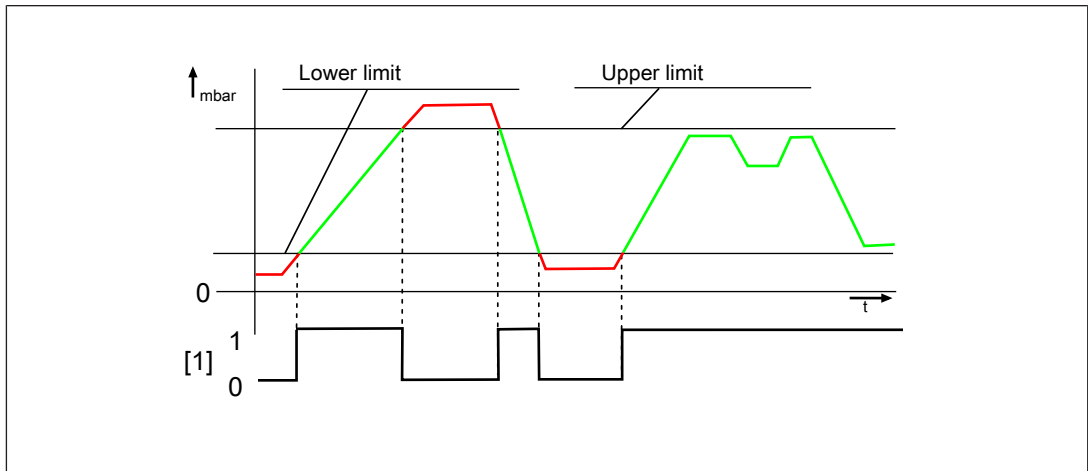

Fig.: Range monitoring

Legend

- [1] Evaluation of range monitoring in the user program

Example:

In this example, the scaled values from 0 to 10,000 mbar from the [Scaling \[20\]](#) chapter are to be used. If the pressure falls below 2,000 mbar or exceeds 8,000 mbar, the fact that the range has been exceeded is to be registered in the user program.

Configuration:

Lower limit value: 2,000 mbar

Upper limit value: 8,000 mbar

5.9 Threshold value monitoring

8 thresholds per input can be defined; these can be used to monitor the scaled signal. As a result, various warning and fault levels can be set up when monitoring physical values, for example.

Each threshold consists of a lower and an upper threshold value. The result of monitoring is registered in the user program. For each threshold it is possible to configure whether to register in the user program that the value has exceeded the upper threshold value or fallen below the lower threshold value.

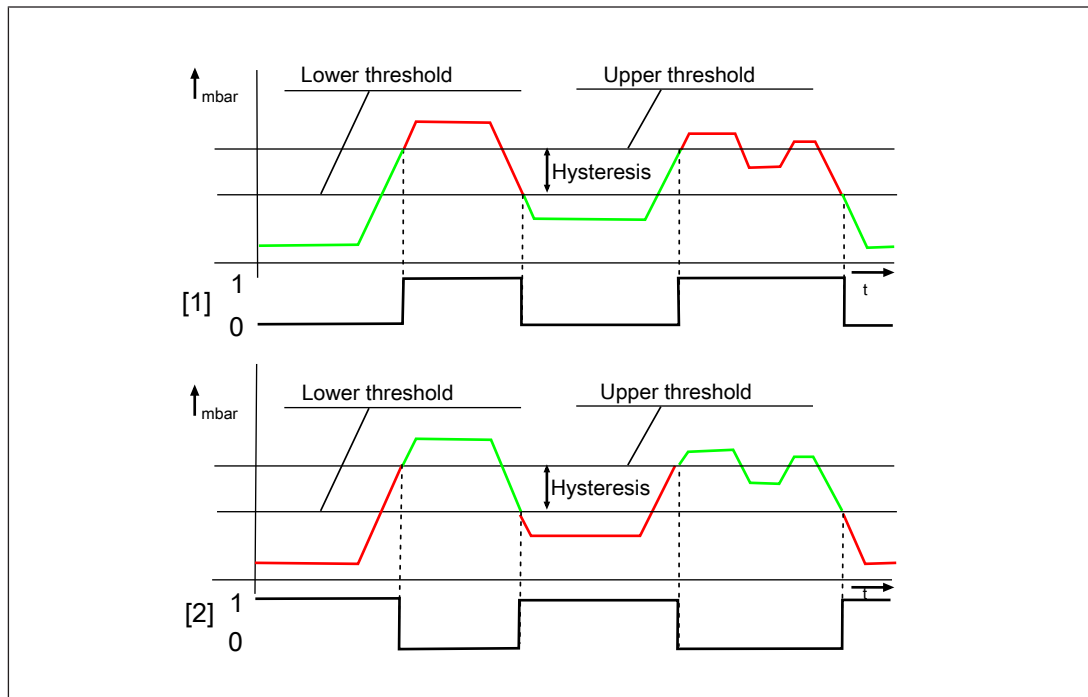

Fig.: Threshold value monitoring

Legend

- [1] Configuration-dependent evaluation of the threshold value in the user program, monitored for values above the limit:
 - ▶ Bit is set when the value has exceeded the upper threshold value.
 - ▶ Bit is reset when the value falls below the lower threshold value.
- [2] Configuration-dependent evaluation of the threshold value in the user program, monitored for values below the limit:
 - ▶ Bit is set when the value falls below the lower threshold value.
 - ▶ Bit is reset when the value exceeds the upper threshold value.

Example:

The scaled values from 0 to 10,000 mbar under [Scaling \[20\]](#) are to be used in this example. If the pressure of 8,000 mbar is exceeded, the fact that the threshold value has been exceeded is to be registered in the user program.

Configuration for a hysteresis of 100 mbar:

Upper threshold value: 8,000 mbar

Lower threshold value: 7,900 mbar

5.10 Data format

The data format enables the scaled digital value to be represented as:

- ▶ Two's complement (default data format)
The scaled digital values are transferred with 16 bits.
- ▶ Sign and magnitude representation (only remote I/O system PSS u2)
The scaled digital values are transferred with 15 bits plus a sign bit (MSB). The MSB is "1" with negative values and "0" with positive values.

Sign and magnitude representation and two's complement representation differ only on negative values.

Analogue value in a two's complement with default values for scaling:

Analogue value 0.1 mA ... 25.6 mA	Binary	Hexadecimal	Decimal
25.59921875 mA (25.6 mA – 1 LSB)	0111 1111 1111 1111	7FFF _H	32767
20.0 mA	0110 0100 0000 0000	6400 _H	25600
17.5 mA	0101 0111 1000 0000	5780 _H	22400
15.0 mA	0100 1011 0000 0000	4B00 _H	19200
12.5 mA	0011 1110 1000 0000	3E80 _H	16000
10.0 mA	0011 0010 0000 0000	3200 _H	12800
7.5 mA	0010 0101 1000 0000	2580 _H	9600
5.0 mA	0001 1001 0000 0000	1900 _H	6400
2.5 mA	0000 1100 1000 0000	0C80 _H	3200
1.0 mA	0000 0101 0000 0000	0500 _H	1280
0.1 mA	0000 0000 1000 0000	0080 _H	128
50 µA	0000 0000 0100 0000	0040 _H	64
25 µA	0000 0000 0010 0000	0020 _H	32
12.5 µA	0000 0000 0001 0000	0010 _H	16
6.25 µA	0000 0000 0000 1000	0008 _H	8
3.125 µA	0000 0000 0000 0100	0004 _H	4
1.5625 µA	0000 0000 0000 0010	0002 _H	2
0.78125 µA	0000 0000 0000 0001	0001 _H	1

Analogue value 0.1 mA ... 25.6 mA	Binary	Hexadecimal	Decimal
0 A	0000 0000 0000 0000	0000 _H	0
-0.1 mA	1111 1111 1000 0000	FF80 _H	-128

Analogue value in a sign and magnitude representation with default values for scaling:

(Sign and magnitude representation can only be configured in the remote I/O system PSS u2. The default data format is always in two's complement.)

Analogue value 0.1 mA ... 25.6 mA	Binary	Hexadecimal	Decimal
25.59921875 mA (25.6 mA – 1 LSB)	0111 1111 1111 1111	7FFF _H	32767
20.0 mA	0110 0100 0000 0000	6400 _H	25600
17.5 mA	0101 0111 1000 0000	5780 _H	22400
15.0 mA	0100 1011 0000 0000	4B00 _H	19200
12.5 mA	0011 1110 1000 0000	3E80 _H	16000
10.0 mA	0011 0010 0000 0000	3200 _H	12800
7.5 mA	0010 0101 1000 0000	2580 _H	9600
5.0 mA	0001 1001 0000 0000	1900 _H	6400
2.5 mA	0000 1100 1000 0000	0C80 _H	3200
1.0 mA	0000 0101 0000 0000	0500 _H	1280
0.1 mA	0000 0000 1000 0000	0080 _H	128
50 µA	0000 0000 0100 0000	0040 _H	64
25 µA	0000 0000 0010 0000	0020 _H	32
12.5 µA	0000 0000 0001 0000	0010 _H	16
6.25 µA	0000 0000 0000 1000	0008 _H	8
3.125 µA	0000 0000 0000 0100	0004 _H	4
1.5625 µA	0000 0000 0000 0010	0002 _H	2
0.78125 µA	0000 0000 0000 0001	0001 _H	1
0 A	0000 0000 0000 0000	0000 _H	0
-0.1 mA	1000 0000 1000 0000	8080 _H	-128

5.11 Summary of configuration options

The module has the following configuration options:

Configurable properties	Default value	Meaning
IO(1,3): Measuring range		
Measuring range	0 ... +25.6 mA	
IO(1,3): Working range monitoring		
Use monitoring	No	Deactivated
Lower limit value	4608 _D	3.6 mA
Upper limit value	26880 _D	21mA
Timeout	1 ms	Period for which an overshoot or undershoot will be tolerated
IO(1,3): Filter with moving averaging		
Time for averaging	1 ms	The filter is implemented by forming the moving average (see Moving averaging)
IO(1,3): Scaling		
Lower limit value of the measuring range	-128 _D	Lower measuring range limit
Upper limit value of the measuring range	32767 _D	Upper measuring range limit
Lower limit value of the scaled range	-128 _D	Default value of the lower measuring range limit
Upper limit value of the scaled range	32767 _D	Default value of the upper measuring range limit
IO(1,3): Range monitoring		
Range 1		
Lower limit value	-32768 _D	Lower limit of the number range that can be represented
Upper limit value	32767 _D	Upper limit of number range that can be represented
IO(1,3): Threshold value monitoring		
Threshold 1		
Lower threshold value	-32768 _D	Lower limit of the number range that can be represented
Upper threshold value	32767 _D	Upper limit of number range that can be represented
Operator for threshold monitoring	Value below the lower threshold value	Undershooting of the lower threshold value is signalled in the user program.
Data format	Two's complement	Two's complement is activated

5.12 Reaction times

When calculating reaction times, please note that a used digital filter in the form of a moving averaging always results in attenuation and a delay of the (input) signal.

Information on the reaction times is available in the operating manuals for the head modules or in the System Description PSS 4000.

5.13 Energy-saving functions

The energy-saving levels are controlled by the head module and are not configurable. The module supports the following energy-saving levels:

▶ Switching off the LEDs

The LEDs have two energy-saving levels:

- Switching off the LEDs to display the terminal status
- Switching off the LEDs to display the module and terminal status

▶ Standby mode

- All module functions are inactive.
- The LEDs for displaying the module and terminal status are switched off.

6 Structure of the process image (Remote I/O system PSS u2)

When the electronic module is used in the remote I/O system, the data described below are available.

ST-PII

The module occupies 16 Bytes in the process image of inputs.

Input	Byte	Bit	Meaning	Values
I0	0	0	Valid bit	1: Input value is valid 0: Input value is invalid
		1	Working range monitoring	1: Inside the range 0: Outside the range
		2	Unused	- - -
		3	Value range monitoring of the scaled analogue input	1: Value to be scaled is outside the value range 0: Value to be scaled is inside the value range
		4	Range monitoring 0	1: Inside the defined range 0: Outside the defined range
		5	Range monitoring 1	1: Inside the defined range 0: Outside the defined range
		6	Range monitoring 2	1: Inside the defined range 0: Outside the defined range
		7	Range monitoring 3	1: Inside the defined range 0: Outside the defined range
	1	0 ... 7	Threshold value monitoring Threshold 0 (Bit 0) to threshold 7 (Bit 7)	1: Exceeds or falls below threshold value 0: Does not exceed or fall below threshold value
8, 9	0 ... 15	Scaled input value	-32768 ... 32767	

Input	Byte	Bit	Meaning	Values
I1	2	0	Valid bit	1: Input value is valid 0: Input value is invalid
		1	Working range monitoring	1: Inside the range 0: Outside the range
		2	Unused	- - -
		3	Value range monitoring of the scaled analogue input	1: Value to be scaled is outside the value range 0: Value to be scaled is inside the value range
		4	Range monitoring 0	1: Inside the defined range 0: Outside the defined range
		5	Range monitoring 1	1: Inside the defined range 0: Outside the defined range
		6	Range monitoring 2	1: Inside the defined range 0: Outside the defined range
		7	Range monitoring 3	1: Inside the defined range 0: Outside the defined range
	3	0 ... 7	Threshold value monitoring Threshold 0 (Bit 0) to threshold 7 (Bit 7)	1: Exceeds or falls below threshold value 0: Does not exceed or fall below threshold value
	10, 11	0 ... 15	Scaled input value	-32768 ... 32767

Input	Byte	Bit	Meaning	Values
I2	4	0	Valid bit	1: Input value is valid 0: Input value is invalid
		1	Working range monitoring	1: Inside the range 0: Outside the range
		2	Unused	- - -
		3	Value range monitoring of the scaled analogue input	1: Value to be scaled is outside the value range 0: Value to be scaled is inside the value range
		4	Range monitoring 0	1: Inside the defined range 0: Outside the defined range
		5	Range monitoring 1	1: Inside the defined range 0: Outside the defined range
		6	Range monitoring 2	1: Inside the defined range 0: Outside the defined range
		7	Range monitoring 3	1: Inside the defined range 0: Outside the defined range
	5	0 ... 7	Threshold value monitoring Threshold 0 (Bit 0) to threshold 7 (Bit 7)	1: Exceeds or falls below threshold value 0: Does not exceed or fall below threshold value
	12, 13	0 ... 15	Scaled input value	-32768 ... 32767

Input	Byte	Bit	Meaning	Values
I3	6	0	Valid bit	1: Input value is valid 0: Input value is invalid
		1	Working range monitoring	1: Inside the range 0: Outside the range
		2	Unused	- - -
		3	Value range monitoring of the scaled analogue input	1: Value to be scaled is outside the value range 0: Value to be scaled is inside the value range
			Range monitoring 0	1: Inside the defined range 0: Outside the defined range
			Range monitoring 1	1: Inside the defined range 0: Outside the defined range
			Range monitoring 2	1: Inside the defined range 0: Outside the defined range
			Range monitoring 3	1: Inside the defined range 0: Outside the defined range
	7	0 ... 7	Threshold value monitoring Threshold 0 (Bit 0) to threshold 7 (Bit 7)	1: Exceeds or falls below threshold value 0: Does not exceed or fall below threshold value
	14, 15	0 ... 15	Scaled input value	-32768 ... 32767

7 I/O data of the module (PSS u2 in the automation system PSS 4000)

When the electronic module for PSS u2 is used in the automation system PSS 4000, the data described below are available.

7.1 Available I/O data in the I/O mapping

Data access is via pre-defined I/O data types:

I/O data name (Terminal)	I/O data type	Data element: Data type	Meaning	Values
I0(1,3) I1(5,7) I2(9,11) I3(13,15)	ST_I_AI2	Data: INT	Analogue input value (two's complement only)	1: Input value is valid 0: Input value is invalid
		WorkingRange: BOOL	Working range monitoring	1: Inside the range 0: Outside the range
		ScalingLimit: BOOL	Value range monitoring	1: Value to be scaled is outside the value range 0: Value to be scaled is inside the value range
		Range0: BOOL	Range monitoring 0	1: Inside the defined range 0: Outside the defined range
		Range1: BOOL	Range monitoring 1	
		Range2: BOOL	Range monitoring 2	
		Range3: BOOL	Range monitoring 3	
		LimitValue0: BOOL	Threshold monitoring Threshold 0	1: Exceeds or falls below threshold value 0: Does not exceed or fall below threshold value
		LimitValue1: BOOL	Threshold monitoring Threshold 1	
		LimitValue2: BOOL	Threshold monitoring Threshold 2	
		LimitValue3: BOOL	Threshold monitoring Threshold 3	
		LimitValue4: BOOL	Threshold monitoring Threshold 4	
		LimitValue5: BOOL	Threshold monitoring Threshold 5	
LimitValue6: BOOL	Threshold monitoring Threshold 6			
LimitValue7: BOOL	Threshold monitoring Threshold 7			

7.2 Other I/O data

In addition to the I/O data available via I/O mapping, it is possible to access further I/O data in the user program:

- ▶ Valid bit of input I0
- ▶ Valid bit of input I1
- ▶ Valid bit of input I2
- ▶ Valid bit of input I3

The following applies to all valid bits:

- ▶ 1: Input value is valid
- ▶ 0: Input value is invalid

In the Multi programming, access is via the PSS 4000 system control block "Valid".

In IEC 61131 programming, access is via the variable extension "WITH VALID".

8 Installation

8.1 General installation guidelines



NOTICE

R-type electronic modules may only be installed on R-type backplanes.



CAUTION!

Risk of material damage

The incorrect ambient temperature during assembly/dismantling can lead to material damage.

- Comply with the permitted ambient temperature for assembly/dismantling: -20°C ... +45°C



CAUTION!

Risk of material damage

Electrostatic discharge can damage components.

- Ensure against discharge before touching the product, e.g. by touching an earthed, conductive surface or by wearing an earthed arm-band.

8.1.1 Dimensions

The dimensions include the backplane, electronic module and terminal block.

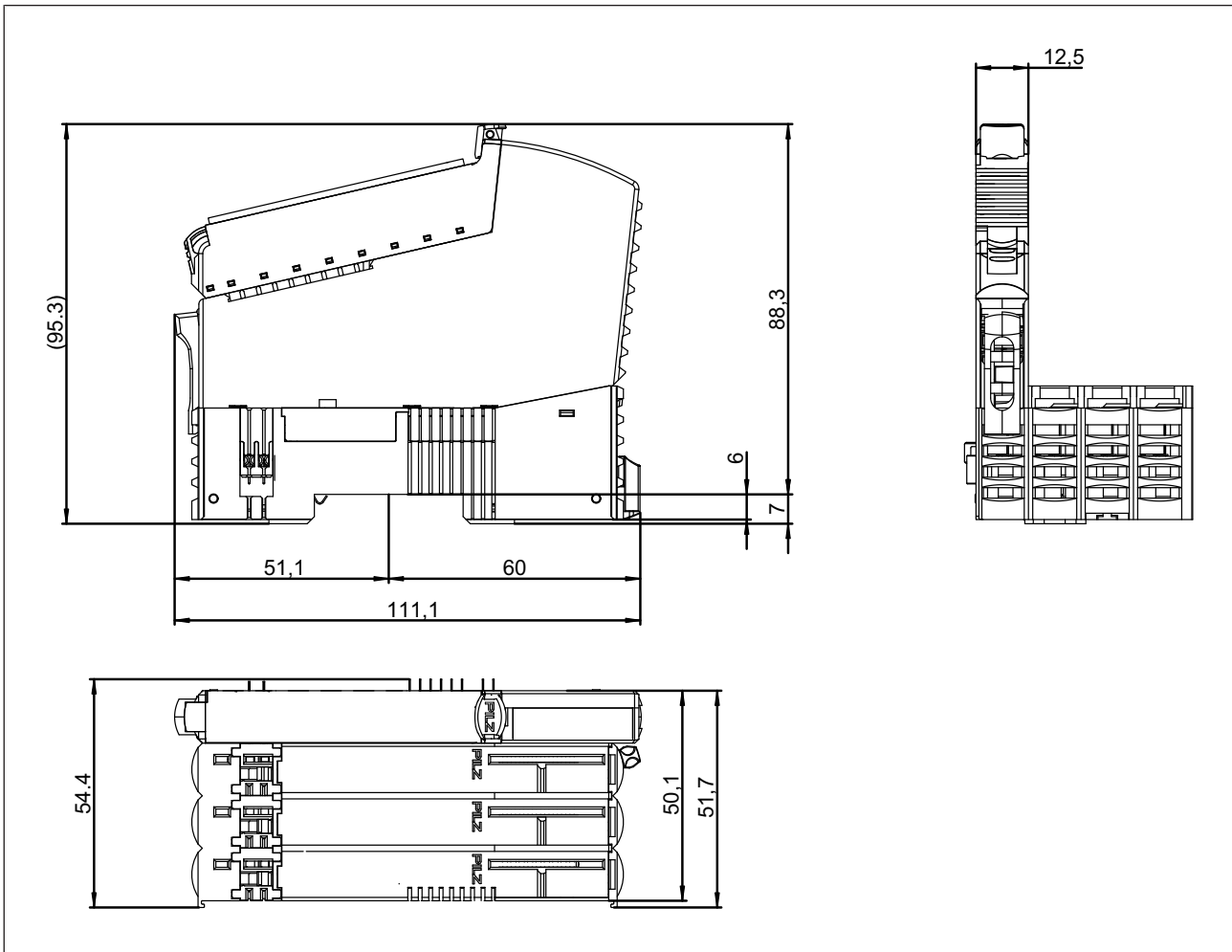

Fig.: Dimensions in mm, including backplane, electronic module and terminal block

8.2 Inserting and removing an electronic module

Please note:

- ▶ Backplane must be installed first.
- ▶ Electronic modules may only be plugged or unplugged if the terminal block has been removed first.
- ▶ The mechanics of the electronic modules are designed for 20 plug in/out cycles.

The following illustrations in chapters "Inserting an electronic module", "Removing an electronic module" and "Changing an electronic module during operation" are displayed as an example in the remote I/O system PSS u2 (see [Terminology \[5\]](#)).

8.2.1 Inserting an electronic module

1. Insert the electronic module into the suspension lug on the back-plane.

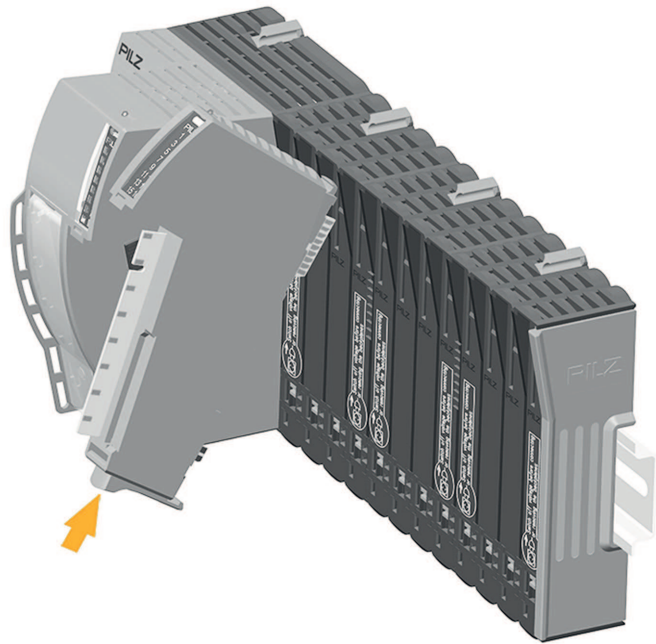

2. Swivel the electronic module downwards until you hear it click into place.

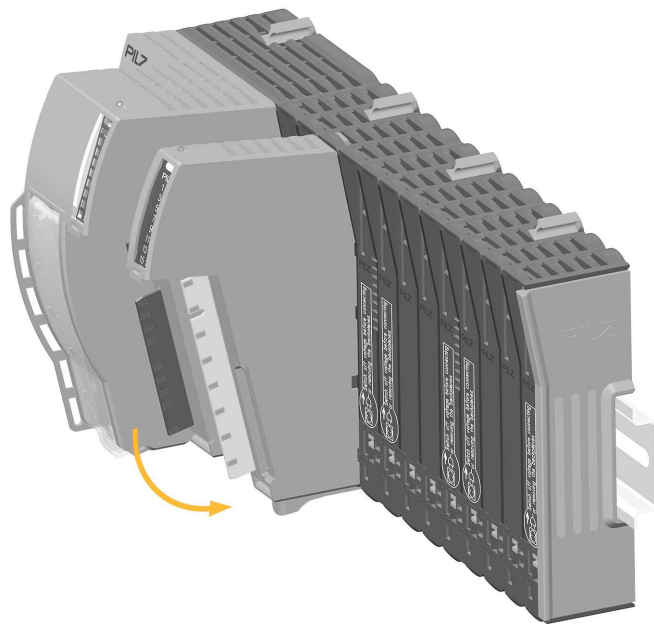

3. Insert the terminal block into the suspension lug on the module.

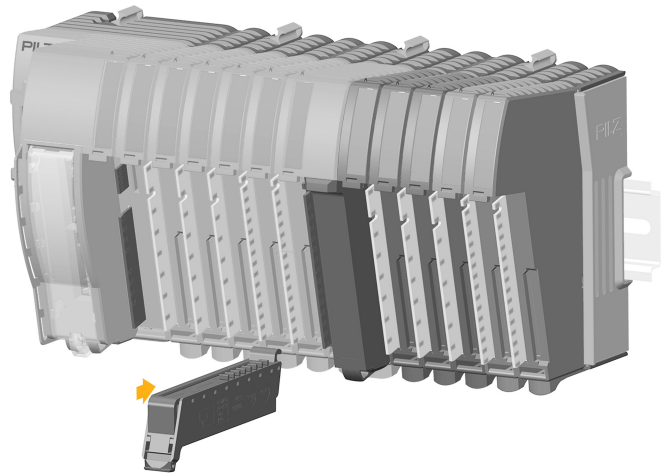

4. Swivel the terminal block upwards until you hear it click into place.

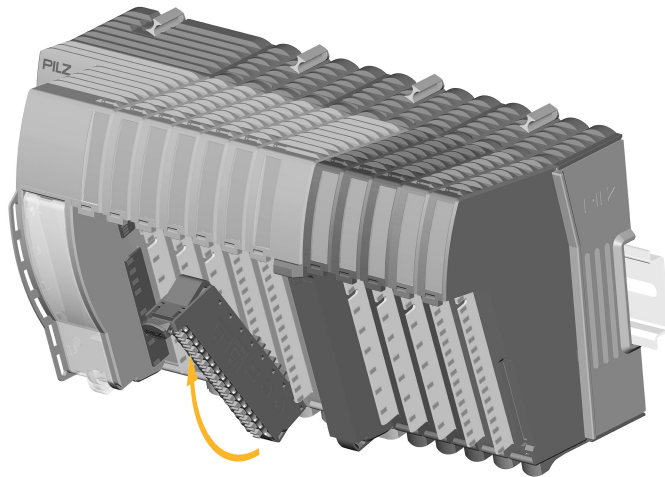

8.2.2 Removing an electronic module

1. Press the unlocking mechanism on the terminal block that is shown by the arrow and pull off the terminal block forward.

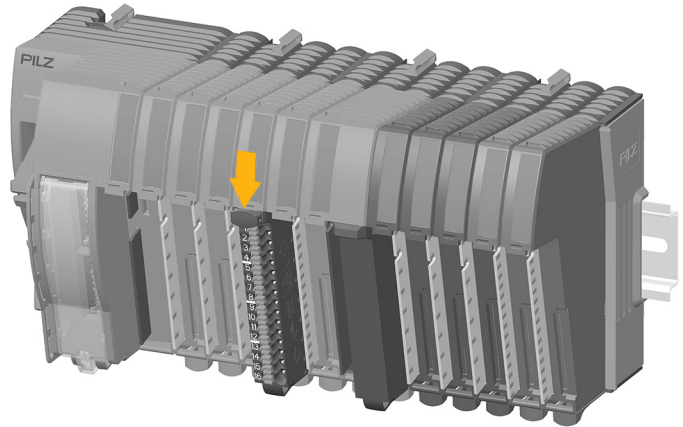

2. Press the unlocking mechanism that is shown by the arrow and pull off the electronic module upwards.

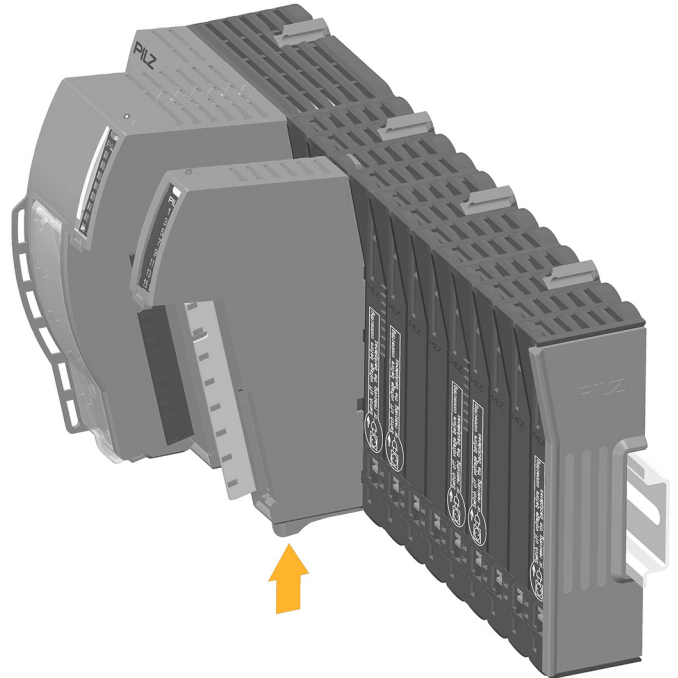

8.2.3 Changing an electronic module during operation

An electronic module can be hot swapped.

Effects

- ▶ Module bus communication between the other modules is not interrupted.
- ▶ The configuration data is retained (exchanging an electronic module with identical product ID).
- ▶ The module is detected automatically as soon as it is re-inserted.

Procedure

1. Removing an electronic module
2. Inserting an electronic module

A new electronic module can be inserted during operation.

Procedure (inserting an electronic module with a different product ID).

- ▶ Insert electronic module

Effects

- ▶ Module bus communication between the other modules is not interrupted.
- ▶ To detect the new module the following steps may be necessary:
 - Creating a new configuration or changing an existing configuration
 - Download of the configuration to the head module
 - Restart of the head module (supply voltage on/off) or warm reset via reset button.

9 Wiring

9.1 General wiring guidelines

- ▶ Each input is protected against overload by an internal current-limiting circuit. Over-voltages at the input must not exceed 30 V.
- ▶ The supply voltages of the actuators and encoders must meet the regulations for extra low voltages with safe separation (SELV, PELV). Failure to do so could result in electric shock.
- ▶ Use shielded signal cables. The optional shield connection element can be used to connect the shield (see Accessories).
- ▶ Use copper wiring.
- ▶ Analogue input modules detect even very small signal changes. They are therefore much more sensitive than digital inputs. In a particularly disturbed environment it can happen that signal changes caused by interferences are also detected.

In these cases, we recommend the following measures:

- Earth the mounting rail on both sides of the modules.
- Earth the shield connection of the cables on both sides (on the sensor and either on the module or directly on the point where the cable enters the control cabinet).
- Ensure that no transient currents flow across the cable screening, which may damage the cables or the connectors.

9.2 Terminal configuration

Terminal	Terminal configuration
1	I0+ current input positive
2	0V _(a) ground analogue input
3	I0- current input negative
4	P0 shield connection
5	I1+ current input positive
6	0V _(a) ground analogue input
7	I1- current input negative
8	P0 shield connection
9	I2+ current input positive
10	0V _(a) ground analogue input
11	I2- current input negative
12	P0 shield connection
13	I3+ current input positive
14	0V _(a) ground analogue input
15	I3- current input negative
16	P0 shield connection

9.2.1 Connection examples

In an EMC-disturbed environment, the sensors must be supplied from separate voltage sources.

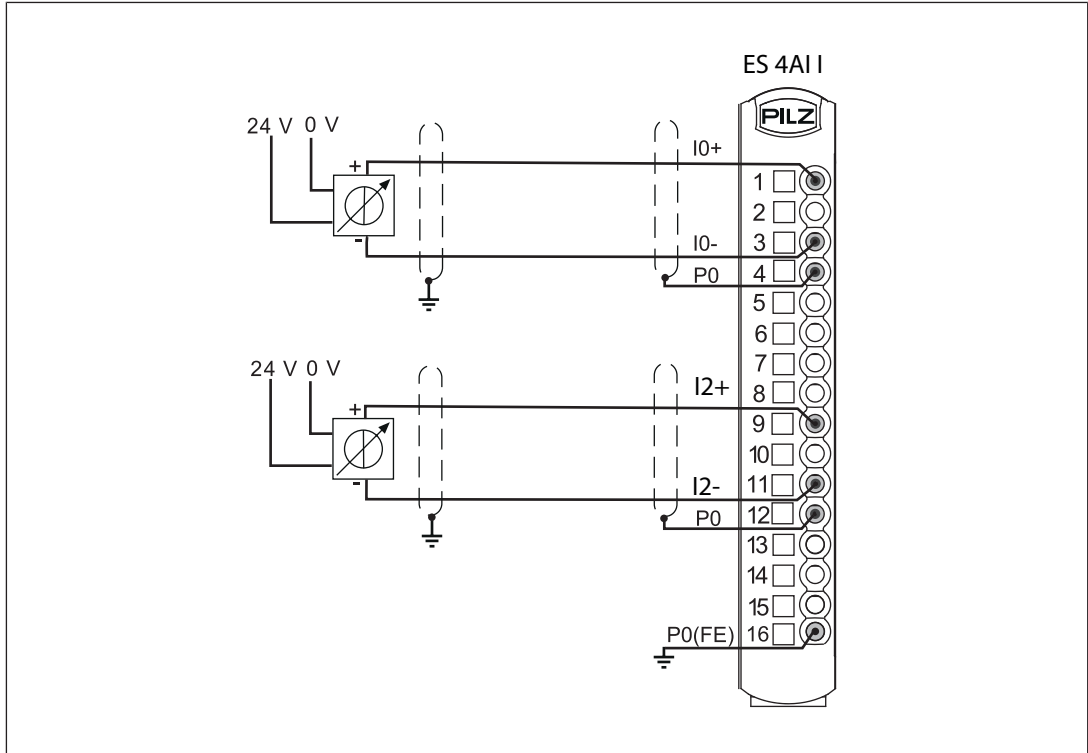

Fig.: Current measurement in an EMC-disturbed environment

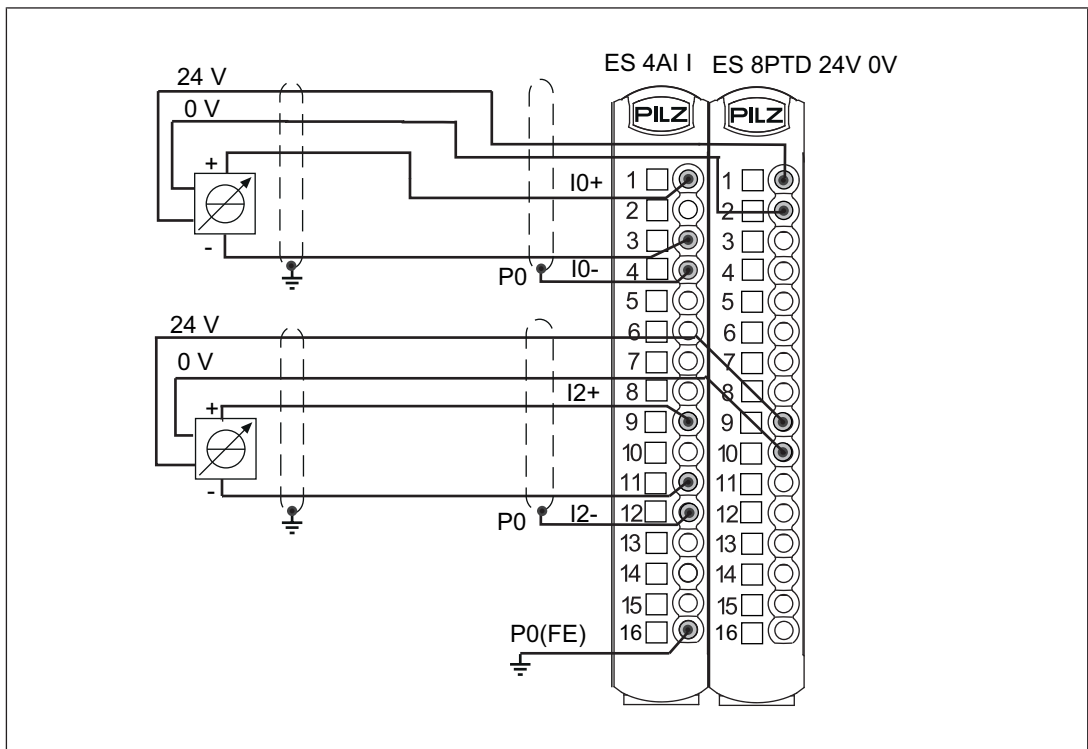

Fig.: Current measurement in sufficiently EMC-protected environment



NOTICE

Not galvanically isolated supply of the sensors

Please note that in a connection type without galvanically isolated supply of the sensors the module can be damaged by surge voltages.

10 Operation

The status of the module is displayed via a red and a green LED. The status of the terminals is displayed via a green LED. If there is a module error, the module status display will light up red. The error will be signalled to the head module and will be entered in the head module's diagnostic log.

10.1 Display elements and messages



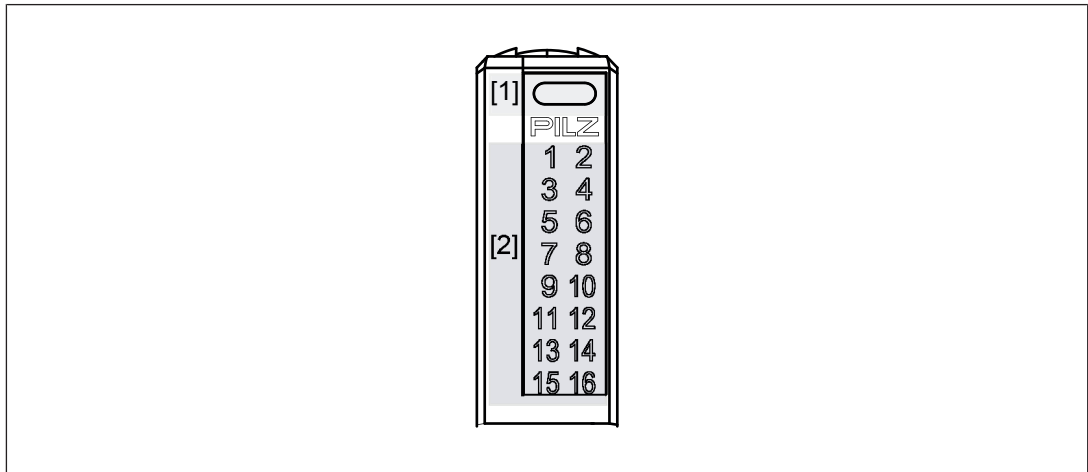











Only the terminal status displays 1,3,5,7,9,11,13 and 15 are active.





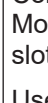

Legend

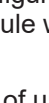
- [1] Module status display
- [2] Terminal status display

The module can detect the following module states:

[1]	Colour [1]	[2]	Colour [2]	Meaning	Further information
	--			Module not ready for operation	
	Green			Module ready for operation	
	Green		Green	Module in operation and there is a valid input value at the relevant input	
	Red		--	Configuration error Module was inserted in the wrong slot. Use of unreleased firmware	
	Red		--	Internal errors	See module's diagnostic log
	Red		Green	The module status display and both terminal status displays on the relevant input flash synchronously. Measuring range error/scaling error	See module's diagnostic log
	Red		Green	Temperature warning: too warm ^[1] Warning, e.g. undervoltage	See module's diagnostic log
	Red		Green	The module status display and all terminal status displays flash synchronously. Periphery supply is missing/temperature error: too hot ^[1] /sensor supply overloaded	See module's diagnostic log

Legend

-  LED on
-  LED flashes
-  LED flashes
-  LED off

^[1] There are two levels of overtemperature.

▶ Too warm:

If the module temperature exceeds a threshold value, then:

- a warning is sent to the head module.

If the temperature drops back below the threshold value, the module sends an all-clear.

▶ Too hot:

If the module temperature exceeds another threshold value, then:

- an error message is sent to the head module
- the voltage outputs are switched off.
- the inputs continue to be read and appear in the ST-PII. The valid bits for the voltage outputs are set to "0".

After the "too hot" message has been received, if the temperature drops back below the "too warm" threshold value, the module will switch to an error-free state.

11 Technical details

Where standards are undated, the 2025-03 valid editions apply.

General	328520	327520
Certifications	CE, UKCA, cULus Listed	CE, UKCA, cULus Listed
Application range	Standard	Standard
Module's device code	0024h	0C24h
Electrical data	328520	327520
Supply voltage		
Max. power consumption of an input	0,12 W	0,12 W
Internal voltage supply (module supply)		
Module's power consumption	0,21 W	0,21 W
Periphery's voltage supply (periphery supply)		
Module's power consumption with no load	0,2 W	0,2 W
Max. power dissipation of module	0,9 W	0,9 W
Process data remote IO system PSS u2	328520	327520
Number of ST input bytes; if the assignment is incomplete, the assigned bits are stated in brackets	16(124)	16(124)
Analogue inputs	328520	327520
Number of analogue inputs	4	4
Type of analogue inputs	Current	Current
Measuring ranges		
Type	Differential input	Differential input
Measuring range	0 - 25,6 mA	0 - 25,6 mA
Input filter	RC filter, 1st order	RC filter, 1st order
Cutoff frequency	700 Hz	700 Hz
Current measurement		
Value of least significant bit (LSB)	0,78125 µA	0,78125 µA
input resistance	100 Ohm + approx. 1.6 V threshold voltage	100 Ohm + approx. 1.6 V threshold voltage
Max. continuous voltage	30 V	30 V
Resolution	15 Bit	15 Bit
Deviations from the measuring range limit value		
Linearity error	0,05 %	0,05 %
Output variable error at 25 °C	0,3 %	0,3 %
Temperature coefficient	0,003 %/K	0,003 %/K
Repetition accuracy at 25 °C	0,05 %	0,05 %

Analogue inputs		
	328520	327520
Monotony without error codes	Yes	Yes
Conversion method	Successive approximation	Successive approximation
Max. processing time tProclM of analogue input	tInput- & tSW filter + 0.1 ms	tInput- & tSW filter + 0.1 ms
Software filter time (averaging)	0,1 ms, 0,2 ms, 0,5 ms, 1 ms, 2 ms, 5 ms, 10 ms, 17 ms, 20 ms	0,1 ms, 0,2 ms, 0,5 ms, 1 ms, 2 ms, 5 ms, 10 ms, 17 ms, 20 ms
Potential isolation	Yes	Yes
Environmental data		
	328520	327520
Application site		
in accordance with the standard	–	EN 50125-3
Application site	–	Minimum 1m distance from track
Climatic suitability	EN 60068-2-1, EN 60068-2-2, EN 60068-2-30, EN 60068-2-78, EN IEC 60068-2-14	EN 60068-2-1, EN 60068-2-2, EN 60068-2-30, EN 60068-2-78, EN IEC 60068-2-14
Ambient temperature		
Temperature range	-25 - 60 °C	-40 - 70 °C
in accordance with the standard	UL 61010	UL 61010
Max. temperature in accordance with UL	-25 - 60 °C	-40 - 60 °C
Storage temperature		
Temperature range	-40 - 70 °C	-40 - 70 °C
Climatic suitability		
in accordance with the standard	EN 60068-2-78	EN 60068-2-78
Humidity	95 % r. h. at 40 °C	95 % r. h. at 40 °C
Condensation during operation	Not permitted	EN 60068-2-30
Max. operating height above SL	5000 m	5000 m
EMC	EN 12015, EN 12016, EN 298, EN 50156-1, EN 61131-2 (Zone B), EN IEC 61000-6-2, EN IEC 61000-6-4	EN 12015, EN 12016, EN 298, EN 50121-4, EN 50156-1, EN 61000-6-7, EN 61131-2 (Zone B), EN IEC 61000-6-2, EN IEC 61000-6-4
Vibration		
in accordance with the standard	EN 60068-2-6	EN 60068-2-6
Frequency	8,4 - 150 Hz	8,4 - 150 Hz
Acceleration	10 m/s²	10 m/s²
Broadband noise		
in accordance with the standard	–	EN 60068-2-64
Frequency	–	5 - 2.000 Hz
Acceleration	–	2,3 m/s² eff.

Environmental data	328520	327520
Shock stress		
in accordance with the standard	EN 60068-2-27	EN 60068-2-27
Number of shocks	6	6
Acceleration	150 m/s²	150 m/s²
Duration	11 ms	11 ms
in accordance with the standard	EN 60068-2-27	EN 60068-2-27
Number of shocks	1000	1000
Acceleration	100 m/s²	100 m/s²
Duration	16 ms	16 ms
Airgap creepage		
in accordance with the standard	EN 50156-1, EN 81-20	EN 50156-1, EN 81-20
Overvoltage category	III	III
Pollution degree	2	2
in accordance with the standard	EN 61131-2	EN 61131-2
Overvoltage category	II	II
Pollution degree	2	2
in accordance with the standard	–	EN 50124-1
Overvoltage category	–	OV2
Pollution degree	–	PD2
Protection type		
in accordance with the standard	EN 60529	EN 60529
Housing	IP20	IP20
Terminals	IP20	IP20
Potential isolation	328520	327520
Potential isolation	not evaluated by UL	not evaluated by UL
Potential isolation between	Analogue input and Module Supply	Analogue input and Module Supply
Type of potential isolation	Functional insulation	Functional insulation
Rated surge voltage in operating heights up to max. 2000 m	2500 V	2500 V
Rated surge voltage in operating heights up to max. 5000 m	2200 V	2200 V
Potential isolation between	Analogue input and Periphery Supply	Analogue input and Periphery Supply
Type of potential isolation	Functional insulation	Functional insulation
Rated surge voltage in operating heights up to max. 2000 m	2500 V	2500 V
Rated surge voltage in operating heights up to max. 5000 m	2200 V	2200 V
Potential isolation between	Analogue input and P0	Analogue input and P0
Type of potential isolation	Functional insulation	Functional insulation
Rated surge voltage in operating heights up to max. 2000 m	2000 V	2200 V
Rated surge voltage in operating heights up to max. 5000 m	2000 V	2000 V
Potential isolation between	Periphery supply and module supply	Periphery supply and module supply

Potential isolation	328520	327520
Type of potential isolation	Functional insulation	Functional insulation
Rated surge voltage in operating heights up to max. 2000 m	2500 V	2500 V
Rated surge voltage in operating heights up to max. 5000 m	2200 V	2200 V
Mechanical data	328520	327520
MTBF at 40 °C, 100 % duty cycle (8760 hours/year)	–	252 Jahre
Material		
Housing	PC	PC
Mounting type	plug-in	plug-in
Dimensions		
Height	110,8 mm	110,8 mm
Width	12,5 mm	12,5 mm
Depth	72,5 mm	72,5 mm
Weight	36 g	37 g

12 Supplementary data

12.1 Operating height

The values stated in the technical details apply to the use of the device in operating heights up to max. 2000 m above SL. When used at higher levels, restrictions of the max. ambient temperature (standard IEC 61131-2) must be taken into account.

Operating height above SL [m]	Multiplication factors for the devices' max. ambient temperature
0 ... 2000	1.0
3000	0.9
4000	0.8
5000	0.7

13 Order reference

13.1 Product

Product type	Features	Product ID
PSS u2 ES 4AI I	PSS u2, electronic module for standard applications, 4 analogue inputs, terminal block PSS u2 T 16 required (not supplied with the system)	328520
PSS u2 ES 4AI I -R	PSS u2, electronic module for standard applications, 4 analogue inputs, for increased environmental requirements and railway applications, terminal block PSS u2 T 16 required (not supplied with the system)	327520

13.2 Accessories

Terminal block

Product type	Features	Product ID
PSS u2 T 16 (1 pc.)	Terminal block 16-pin, scope of delivery: 1 piece	328850
PSS u2 T 16 (10 pcs.)	Terminal block 16-pin, scope of delivery: 10 pieces	328851
PSS u2 T 16 (5 x 10 pcs.)	Terminal block 16-pin, scope of delivery: 50 pieces	328852

Labelling bracket

Product type	Features	Product ID
PSS u2 A LC E1 (10 pcs.)	Label holder for electronic module 23.5 x 10.5 mm, scope of delivery: 10 pieces	328910
PSS u2 A LC E2 (10 pcs.)	Label holder for electronic module 103 x 10.5 mm, scope of delivery: 10 pieces	328911
PSS u2 A LA E1 (10 pcs.)	Labelling strips for electronic module 23.5 x 10.5 mm (10 x DIN A4 sheet)	328913
PSS u2 A LA E2 (10 pcs.)	Labelling strips for electronic module 103 x 10.5 mm (10 x DIN A4 sheet)	328914

Label holder for terminal block

Product type	Features	Product ID
PSS u2 A LC T3 (10 pcs.)	Label holder for terminal block 61 x 11.5 mm, scope of delivery: 10 pieces	328912

Coding elements

Product type	Features	Product ID
PSS u2 A CE E (10 pcs.)	Coding elements for electronic modules, scope of delivery: 10 pieces	328860

Backplane

Product type	Features	Product ID
PSS u2 B 1	PSS u2, accessories, backplane, for electronic modules, 1 slot, width 12.6 mm, height 107 mm, note the mounting distances	328811
PSS u2 B 4	PSS u2, accessories, backplane, for electronic modules, 4 slots, width 50.1 mm, height 107 mm, note the mounting distances	328810
PSS u2 B 1 -R	PSS u2, accessories, backplane, for electronic modules, 1 slot, for increased environmental requirements and railway applications, width 12.6 mm, height 107 mm, note the mounting distances	327811
PSS u2 B 4 -R	PSS u2, accessories, backplane, for electronic modules, 4 slots, for increased environmental requirements and railway applications, width 50.1 mm, height 107 mm, note the mounting distances	327810

Shield connection element

Product type	Features	Product ID
PSS u2 A SH 4 (10 pcs.)	Shield connection element for backplane with 4 slots, scope of delivery: 10 pieces	328820

14 EU/EC declaration of conformity

These products meet the requirements of the directive 2006/42/EC on machinery up to and including 19 January 2027, and the EU regulation 2023/1230 of the European Parliament and of the Council from 20 January 2027. The full EU and EC declaration of conformity is available to download at www.pilz.com/manuals.

Authorised representative: Pilz GmbH & Co. KG, Felix-Wankel-Str. 2, 73760 Ostfildern, Germany

15 UKCA-Declaration of Conformity

These products comply with following UK legislation: Supply of Machinery (Safety) Regulation 2008.

The complete UKCA Declaration of Conformity is available on the Internet at www.pilz.com/manuals.

Representative: Pilz Automation Technology, Pilz House, Little Colliers Field, Corby, Northamptonshire, NN18 8TJ United Kingdom, eMail: mail@pilz.co.uk

Support

Technical support is available from Pilz round the clock.

Americas

Brazil

+55 11 97569-2804

Canada

+1 888 315 7459

Mexico

+52 55 5572 1300

USA (toll-free)

+1 877-PILZUSA (745-9872)

Asia

China

+86 400-088-3566

Japan

+81 45 471-2281

South Korea

+82 31 778 3390

Australia and Oceania

Australia

+61 3 95600621

New Zealand

+64 9 6345350

Europe

Austria

+43 1 7986263-444

Belgium, Luxembourg

+32 9 3217570

France

+33 3 88104003

Germany

+49 711 3409-444

Ireland

+353 21 4804983

Italy, Malta

+39 0362 1826711

Scandinavia

+45 74436332

Spain

+34 938497433

Switzerland

+41 62 88979-32

The Netherlands

+31 347 320477

Türkiye

+90 216 5775552

United Kingdom

+44 1536 460866

You can reach our international hotline on:

+49 711 3409-222

support@pilz.com

Pilz develops environmentally-friendly products using ecological materials and energy-saving technologies. Offices and production facilities are ecologically designed, environmentally-aware and energy-saving. So Pilz offers sustainability, plus the security of using energy-efficient products and environmentally-friendly solutions.



We are represented internationally. Please refer to our homepage www.pilz.com for further details or contact our headquarters.

Headquarters: Pilz GmbH & Co. KG, Felix-Wankel-Straße 2, 73760 Ostfildern, Germany
Telephone: +49 711 3409-0, E-Mail: info@pilz.com, Internet: www.pilz.com

PILZ
THE SPIRIT OF SAFETY

CECE, CHRE, CMSE®, INDUSTRIAL Pi®, Leansafe®, Myze®, PAS4000®, PAScal®, PASconfig®, Pilz®, PIT®, PMCPirimo®, PMCProtego®, PMCTiempo®, PMP®, PML®, PNOZ®, Primo®, PSEN®, PSS®, PVIS®, SafetyBUS p®, SafetyNET p®, THE SPIRIT OF SAFETY® are registered and protected trademarks of Pilz GmbH & Co. KG in some countries. We would point out that product features may vary from the details stated in this document, depending on the status at the time of publication and the scope of the equipment. We accept no responsibility for the validity, accuracy and entirety of the text and graphics presented in this information. Please contact our Technical Support if you have any questions.

1005112-EN-05, 2025-04 Printed in Germany
© Pilz GmbH & Co. KG, 2024