



▶ PSENmlock mini PSEN mIm 1 sa 1.1/2.1/2.2

PILZ
THE SPIRIT OF SAFETY

Operating Manual-1005802-EN-07
- PSEN sensor technology



This document is the original document.

Where unavoidable, for reasons of readability, the masculine form has been selected when formulating this document. We do assure you that all persons are regarded without discrimination and on an equal basis.

All rights to this documentation are reserved by Pilz GmbH & Co. KG. Copies may be made for the user's internal purposes. Suggestions and comments for improving this documentation will be gratefully received.

CECE®, CHRE®, CMSE®, INDUSTRIAL PI®, Leansafe®, MYZEL®, PAS4000®, PAS-cal®, PASconfig®, Pilz®, PIT®, PMCprimo®, PMCprotego®, PMctendo®, PMD®, PMI®, PNOZ®, Primo®, PSEN®, PSS®, PVIS®, SafetyBUS p®, SafetyEYE®, SafetyNET p®, THE SPIRIT OF SAFETY® are registered and protected trademarks of Pilz GmbH & Co. KG in some countries.



SD means Secure Digital

1	Introduction	6
1.1	Validity of documentation	6
1.2	Using the documentation	6
1.3	Definition of symbols	6
1.4	Third-party manufacturer licence information	7
2	Safety	8
2.1	Intended use	8
2.2	Safety regulations	9
2.2.1	Safety assessment	9
2.2.2	Additional documents that apply	9
2.2.3	Use of qualified personnel	9
2.2.4	Warranty and liability	10
2.2.5	Disposal	10
2.3	For your safety	10
3	Security	11
4	Overview	12
4.1	Device features	12
4.2	Approved combinations	13
5	Function description	14
5.1	Structure	14
5.2	Safety outputs 12 and 22	16
5.3	Safety inputs S11 and S21 (series connection)	17
5.4	Diagnostic output/signal output Y32	17
5.5	Diagnostic input Y1	17
5.6	Activation of safety inputs S31 and S41 (solenoid operation)	17
5.7	Safety Device Diagnostics	19
5.8	Operating modes	21
5.8.1	Operation without Safety Device Diagnostics	22
5.8.1.1	Timing diagram, case 1 (operation without Safety Device Diagnostics)	22
5.8.1.2	Timing diagram, case 2 (automatic guard locking when closing the safety gate)	23
5.8.2	Operation with active use of Safety Diagnostics	24
5.9	Block diagram	25
5.10	Auxiliary release	26
5.10.1	Recommissioning	27
6	Wiring	29
6.1	Important information	29
6.2	Pin assignment, connector and cable	29
6.3	EMC requirements and electrical safety	30
7	Connection to control systems and evaluation devices	31
7.1	Important information	31
7.2	Minimum requirements for activation of guard locking	32
7.3	Single connection	35

7.4	Series connection.....	36
7.5	Supplement to series connection.....	42
7.6	Connection to Pilz evaluation devices.....	44
8	Teaching in the actuator	46
9	Installation	48
9.1	Important information	48
9.2	Align safety switch and actuator.....	49
9.3	Installation of multiple safety switches	51
9.4	PSEN mlm mounting types	53
9.4.1	External attachment with actuator a.....	53
9.4.1.1	Installation on sliding gate.....	53
9.4.1.2	Installation on swing gate.....	53
9.4.2	Internal attachment with actuator b.....	57
9.5	Installation safety switch	59
9.5.1	Mounting of safety switch using two screws	60
9.6	Actuator installation	61
9.7	Internal attachment: Mounting of safety switch and actuator using mounting set 1 (optional)..	61
9.7.1	Mounting guidelines for internally attached auxiliary release.....	64
10	Operation	65
10.1	PSEN mlm in normal operation.....	65
10.2	PSEN mlm in normal operation.....	67
10.3	Fault indicator PSEN mlm	68
11	Checks and maintenance	70
12	Dimensions	72
13	Technical details	75
14	Use in applications in accordance with IEC 61508 / IEC 61511	90
15	Classification in accordance with ZVEI, CB24I	92
16	Safety characteristic data	94
17	Supplementary data	95
17.1	Radio approval.....	95
18	Order reference	96
18.1	System.....	96
18.2	Accessories.....	97

19	EU/EC declaration of conformity	100
20	EC declaration of conformity	101
21	UKCA-Declaration of Conformity	102

1 Introduction

1.1 Validity of documentation

This operating manual explains the function and operation, describes the installation and provides guidelines on how to connect the product.

This documentation is valid for the product PSEN mIm 1 sa 1.1/2.1/2.2.

1.2 Using the documentation

This document is intended for instruction. Only install and commission the product if you have read and understood this document. The document should be retained for future reference.

1.3 Definition of symbols

Information that is particularly important is identified as follows:



DANGER!

This warning must be heeded! It warns of a hazardous situation that poses an immediate threat of serious injury and death and indicates preventive measures that can be taken.



WARNING!

This warning must be heeded! It warns of a hazardous situation that could lead to serious injury and death and indicates preventive measures that can be taken.



CAUTION!

This refers to a hazard that can lead to a less serious or minor injury plus material damage, and also provides information on preventive measures that can be taken.



NOTICE

This describes a situation in which the product or devices could be damaged and also provides information on preventive measures that can be taken. It also highlights areas within the text that are of particular importance.



INFORMATION

This gives advice on applications and provides information on special features.

1.4 **Third-party manufacturer licence information**

This product includes Open Source software with various licenses.

Further information is available in the document "Third-party manufacturer licence information PSEN mIm 1 ba/sa" (document number 1006757) at www.pilz.com.

2 Safety



INFORMATION

If the auxiliary release screw is not turned back correctly after use, guard locking cannot be activated/deactivated.

2.1 Intended use

PSENmlock mini is used for safe guard locking and safe interlocking on small swing gates and sliding gates, as well as flaps and covers. It prevents a safeguard from being opened while a hazardous machine function is being performed.

The hazardous machine function may only be executed under the following conditions:

- ▶ There is a high signal at safety outputs 12 and 22 and
- ▶ There is a low signal at safety inputs S31 (Lock/Unlock Request 1) and S41 (Lock/Unlock Request 2).

Safety inputs S31 and S41 (solenoid operation) may only be operated when the plant is in a safe state.

- ▶ Ensure that this is the case in the safety controller, for example with an AND operation immediately before the output on the safety controller is activated.

The safety switch meets the requirements in accordance with:

- ▶ EN 60947-5-3: Pddb
- ▶ EN ISO 13849-1: PL d (Cat. 3)
- ▶ EN ISO 14119
 - Interlocking device with guard locking
 - Coding level with actuator PSEN mlm 1 sa 1.1: low, type 4
 - Coding level with actuator PSEN mlm 1 sa 2.1/2.2: high, type 4

The safety switch may only be used with one of the approved actuators (see [Approved combinations](#) [13]). Only mounting aids provided by Pilz may be used to make the attachment.

Safety level PL d (Cat. 3) is only achieved when

- ▶ For the interlock, the safety outputs have 2-channel processing
- ▶ For guard locking, the solenoid has 2-channel operation via safe, tested outputs, suitable for PL d (Cat. 3) applications.

With 1-channel operation of the safety inputs S31 (Lock/Unlock Request 1) and S41 (Lock/Unlock Request 2), it is only possible to achieve safety level PL d (Cat. 2).

The following is deemed improper use in particular

- ▶ Any component, technical or electrical modification to the product,
- ▶ Use of the product outside the areas described in this operating manual, such as
 - Use under corrosive environmental conditions (cooling emulsions, surface treatment, gases, ...),
 - Use in environments with high dust pollution,

- ▶ Use of the safety switch and actuator as mechanical stops,
- ▶ Use of the auxiliary release as a regular release,
- ▶ Use of the product outside the technical details (see Technical details).

2.2 Safety regulations

2.2.1 Safety assessment

Before using a device, a safety assessment in accordance with the Machinery Directive is required.

As an individual component, the product meets functional safety requirements in accordance with EN ISO 13849. However, this does not guarantee the functional safety of the overall plant/machine. To achieve the relevant safety level of the overall plant/machine's required safety functions, each safety function needs to be considered separately.

The safety switch does not have an emergency release.

2.2.2 Additional documents that apply

Please read and take note of the following documents.

Only when using Safety Device Diagnostics (SDD)

- ▶ Fieldbus module operating manual, SDD ES PROFINET (1003826) for example
- ▶ System description Safety Device Diagnostics (1003827)

When using passive junctions

- ▶ Operating manual for a passive junction

When using a series connection

- ▶ System Description, safety switch series connection (1006503)

You will need to be conversant with the information in these documents in order to fully understand this operating manual.

2.2.3 Use of qualified personnel

The products may only be assembled, installed, programmed, commissioned, operated, de-commissioned and maintained by persons who are competent to do so.

A competent person is a qualified and knowledgeable person who, because of their training, experience and current professional activity, has the specialist knowledge required. In order to inspect, assess and handle products, devices, systems, plant and machinery, this person must be familiar with the state of the art and the applicable national, European and international laws, directives and standards.

It is the company's responsibility only to employ personnel who

- ▶ Are familiar with the basic regulations concerning health and safety / accident prevention,
- ▶ Have read and understood the section on "Safety" in this description and
- ▶ Have a good knowledge of the generic and specialist standards applicable to the specific application.

2.2.4 Warranty and liability

All claims to warranty and liability will be rendered invalid if

- ▶ The product was used contrary to the purpose for which it is intended,
- ▶ Damage can be attributed to not having followed the guidelines in the manual,
- ▶ Operating personnel are not suitably qualified,
- ▶ Any type of modification has been made (e.g. exchanging components on the PCB boards, soldering work etc.).

2.2.5 Disposal

- ▶ In safety-related applications, please comply with the mission time T_M stated in the safety-related characteristic data.
- ▶ When decommissioning, please comply with local regulations regarding the disposal of electronic devices (e.g. Electrical and Electronic Equipment Act).

2.3 For your safety



WARNING!

Risk of injury due to loss of the safety function

Replacing an actuator (e.g. defective actuator) with an inappropriate actuator from the interlock and guard locking system may lead to serious injury and death.

- You should prevent the interlocking and guard locking system from being manipulated with an inappropriate actuator.
- Keep the substitute actuator (optional) in a safe place and protect it from unauthorised access.
- Destroy any replaced actuators before disposal.

3 Security

To protect plants, systems, machines and networks against cyberthreats it is necessary to implement (and continuously maintain) an overall Industrial Security concept that is state of the art.

Carry out a risk assessment in accordance with VDI/VDE 2182 or IEC 62443-3-2 and plan the security measures with care.

If you have any questions about implementation, please contact technical support at support@pilz.com.

You can reach the Pilz Product Security Incident Response Team (PSIRT) at <https://www.pilz.com/psirt>.



With regard to a Pilz product, this is where you can:

- ▶ Report security vulnerabilities and security incidents
- ▶ Ask questions about security vulnerabilities and security incidents
- ▶ View Security Advisories

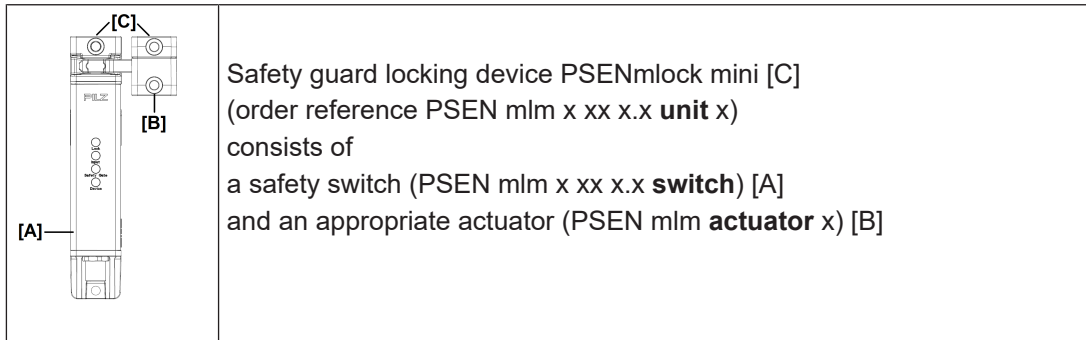
4 Overview



4.1 Device features

- ▶ Safe guard locking for small swing gates and sliding gates, as well as flaps and covers
- ▶ Safe interlocking (position monitoring)
- ▶ Transponder technology
- ▶ 2 safety outputs
- ▶ 2 safety outputs for the solenoids [Series connection](#)  36]
- ▶ 2 safety inputs to activate the solenoid
- ▶ 2 safety inputs for the [series connection](#)  36]
- ▶ Diagnostic input
- ▶ Signal output/diagnostic output
- ▶ Guard locking element keeps the safety gate from being opened unintentionally
- ▶ Auxiliary release for opening the safety gate
- ▶ Suitable for left and right hinged safety gates
- ▶ Pilz coding type
Information about the Pilz coding types can be found under Teaching in the actuator.
 - PSEN mlm x sa 1.1: coded
 - PSEN mlm x sa 2.1: fully coded
 - PSEN mlm x sa 2.2: uniquely coded
- ▶ M12, 12-pin male connector
- ▶ LEDs:
 - Lock: Status of guard locking
 - Input: Status of safety inputs S11 and S21
 - Safety gate: Status of actuator
 - Device: Supply voltage/fault
- ▶ Four types of actuator are available (see Order reference).
 - Actuator a (side mounting, external attachment)
 - Flexible actuator a (side mounting, external attachment)
 - Actuator b (front mounting, internal attachment)
 - Flexible actuator b (front mounting, internal attachment)

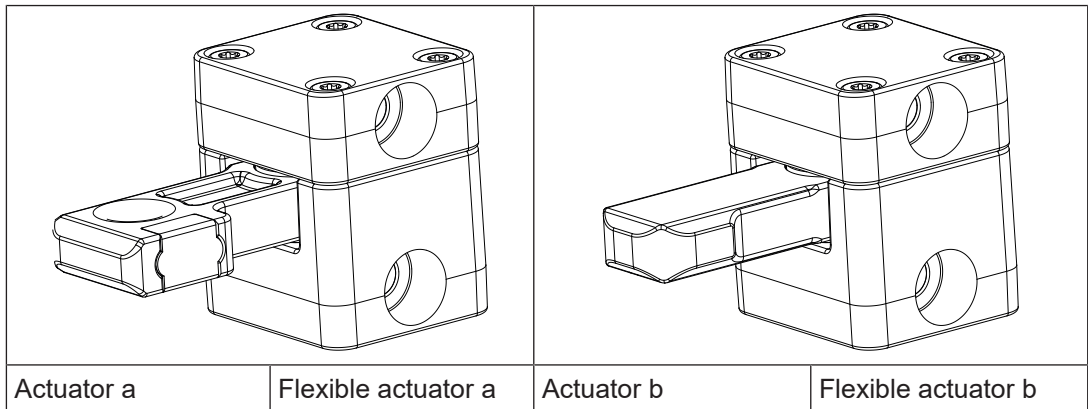

4.2 Approved combinations

An approved combination (unit) consists of a safety switch and the corresponding actuator. For information such as product type, features and order number, see [Order reference](#) [96].

PSEN mlm x sa 1.1

Safety switch	Actuator
PSEN mlm x sa 1.1 switch	PSEN mlm actuator a
	PSEN mlm actuator b
	PSEN mlm actuator af
	PSEN mlm actuator bf

PSEN mlm x sa 2.x

Safety switch	Actuator
PSEN mlm x sa 2.1 switch	PSEN mlm actuator a
	PSEN mlm actuator b
	PSEN mlm actuator af
	PSEN mlm actuator bf
PSEN mlm x sa 2.2 switch	PSEN mlm actuator a
	PSEN mlm actuator b
	PSEN mlm actuator af
	PSEN mlm actuator bf

5 Function description

5.1 Structure

The interlocking and guard locking system prevents the safety gates to the danger zone from being opened while there is any hazard within the danger zone (machine movement, voltage, ...).

The safety outputs 12/22 may have a high or low signal, depending on the position of the actuator, the state of the safety inputs S31/S41 (solenoid activation) and the state of the safety inputs S11/S21.

Safety switch and actuator a, external attachment

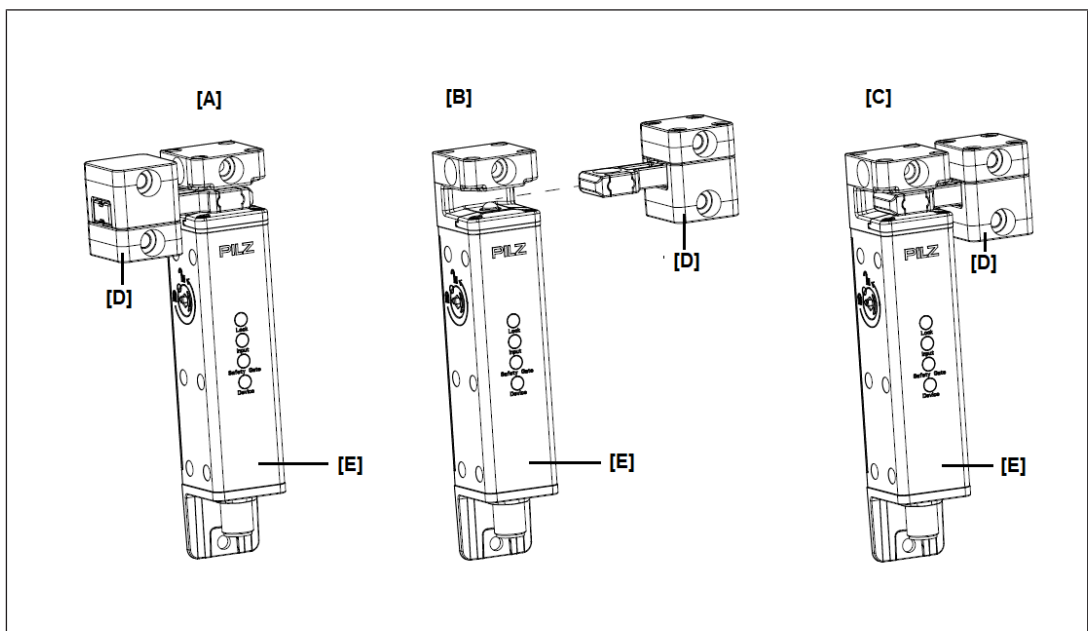

Legend

- [A] Safety switch and actuator **a** (right-hand side mounting, external attachment)
Gate closed
- [B] Safety switch and actuator **a** (left-hand side mounting, external attachment)
Gate open
- [C] Safety switch and actuator **a** (left-hand side mounting, external attachment)
Gate closed
- [D] Actuator **a**
- [E] Safety switch

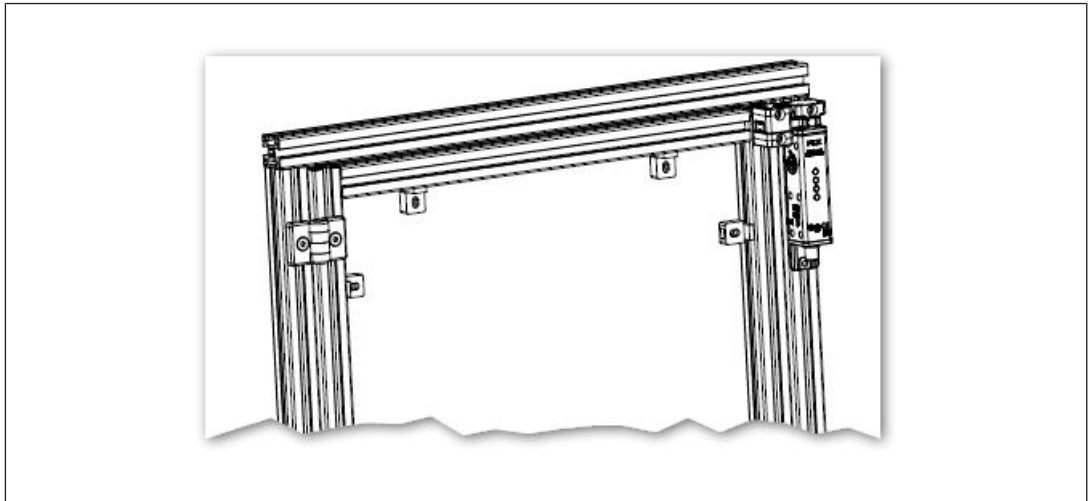
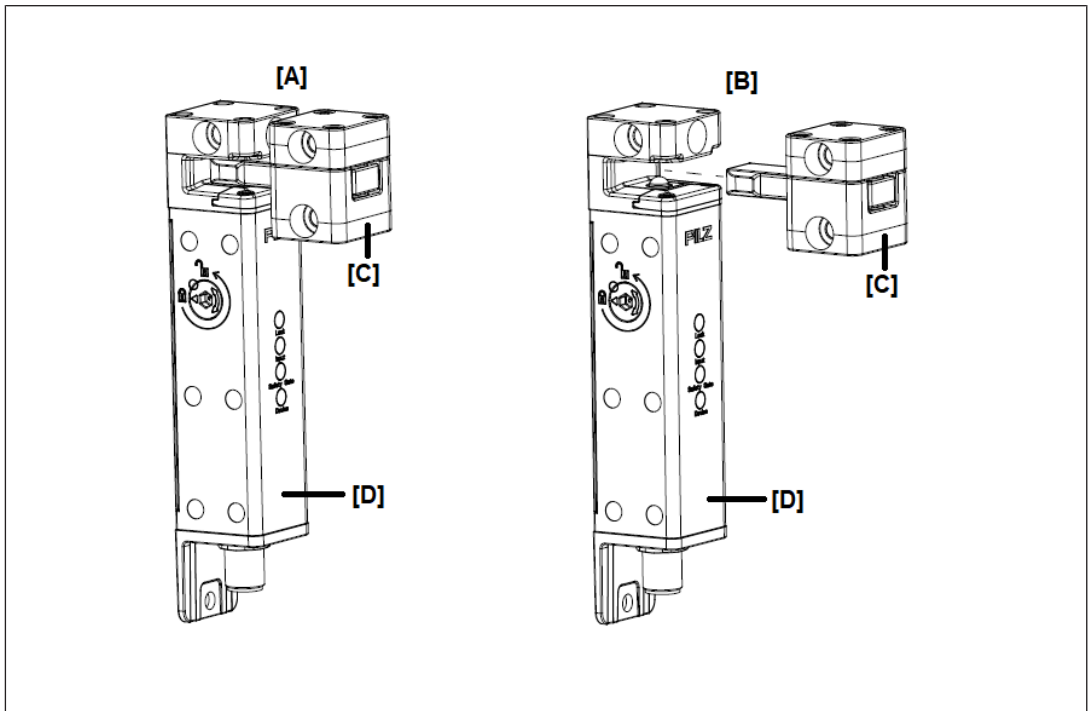

Fig.: Example: External attachment of safety switch and actuator a (left-hand side mounting)

Safety switch and actuator b, internal attachment



Legend

- [A] Safety switch and actuator **b** (front mounting, internal attachment)
Gate closed
- [B] Safety switch and actuator **b** (front mounting, internal attachment)
Gate open
- [C] Actuator **b**
- [D] Safety switch

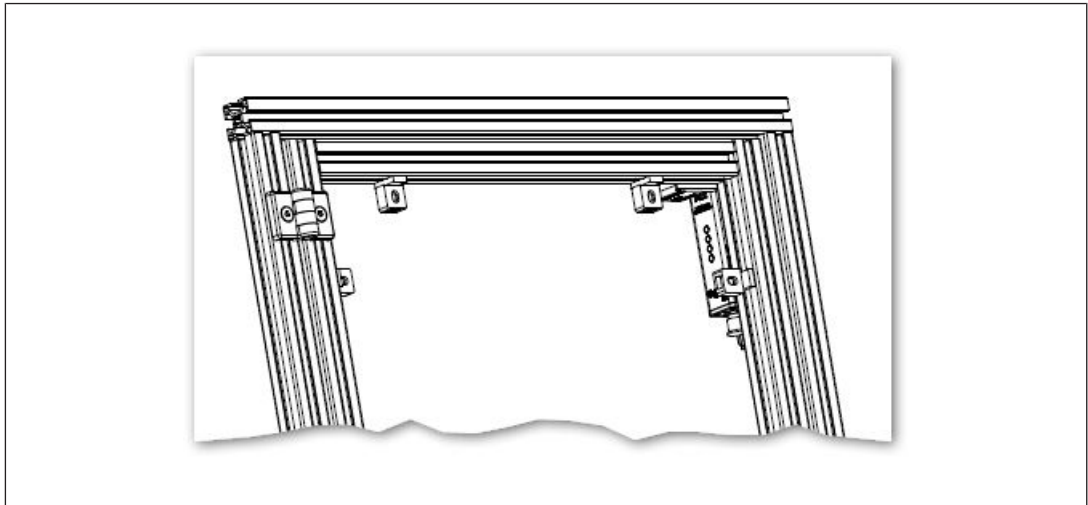

Fig.: Example: Internal attachment of safety switch and actuator b (view from the outside)

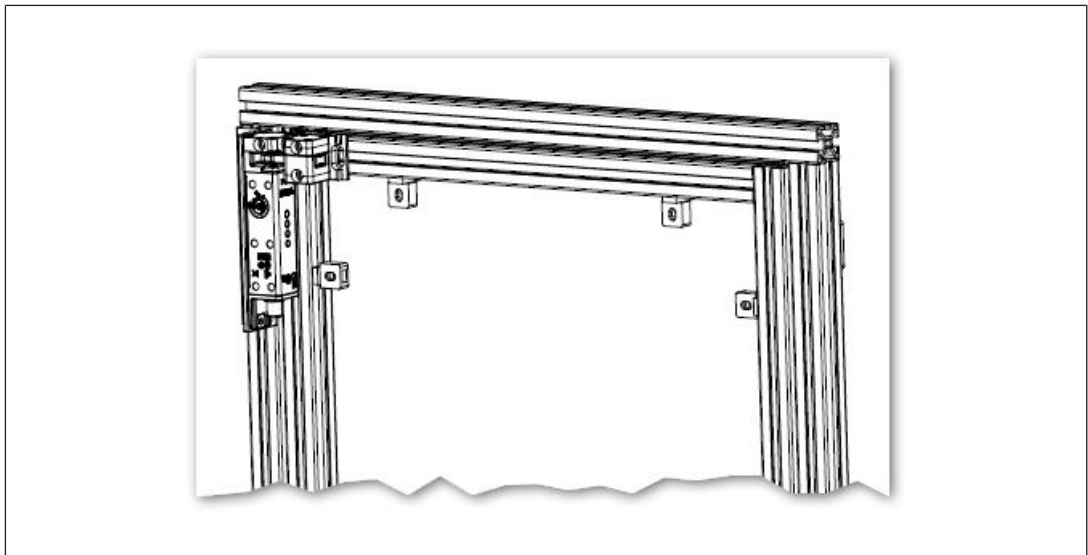

Fig.: Example: Internal attachment of safety switch and actuator b (view from the inside)

5.2 Safety outputs 12 and 22

Under these conditions there is a high signal at safety outputs 12 and 22:

- ▶ The actuator is detected **and**
- ▶ The guard locking pin has been activated successfully (guard locking pin is in the locked position) **and**
- ▶ There is a low signal at the safety inputs S31 and S41 **and**
- ▶ There is a high signal at the safety inputs S11 and S21

If one of these conditions is not met, the signal at the safety outputs will be low.

- ▶ If one safety input S11 or S21 switches from high to low, while the other safety input remains high, safety outputs 12/22 switch off (low) and the Input LED goes out.
- ▶ If this safety input switches back from low to high while the other safety input remains high, safety outputs 12/22 switch to high.

5.3 Safety inputs S11 and S21 (series connection)

The safety switch has safety inputs S11 und S21, enabling additional safety switches to be connected.

If safety input S11/S21 is switched off, safety output 12/22 is also switched off.

Safety outputs 12/22 are connected via safety inputs S11/S21, see [Series connection](#) [ 36].

5.4 Diagnostic output/signal output Y32

▶ Signal output/diagnostic output Y32 without SDD mode

- When the correct actuator has been detected (safety gate detected as closed), there is a high signal at signal output/diagnostic output Y32.

▶ Signal output/diagnostic output Y32 with SDD mode

- If an SDD fieldbus module is used, the signal output/diagnostic output Y32 is activated for writing data.

5.5 Diagnostic input Y1

If an SDD fieldbus module is used, the diagnostic input Y1 is automatically activated and data is read.

If no SDD fieldbus module is used, the diagnostic input Y1 must be connected to 24 V.

In a series connection, the signal output/diagnostic output Y32 must be connected to diagnostic input Y1 on the next sensor in the series connection, see [Series connection](#).

5.6 Activation of safety inputs S31 and S41 (solenoid operation)

Guard locking

- ▶ Guard locking on the safety switch is activated/deactivated via the safety inputs S31 and S41.
- ▶ In the series connection, safety outputs 32/42 forward activation of the solenoid to the next safety switch.
- ▶ Guard locking can only be activated when the actuator provided for the safety switch is engaged (failsafe locking mechanism).
- ▶ Guard locking on the safety switch **is based on a bistable, electromechanical principle.**

If the power supply is interrupted, the guard locking device maintains the last position it had prior to the power interruption. This means:

- Guard locking remains deactivated, if it was deactivated prior to the power interruption
or
 - Guard locking remains activated, if it was activated prior to the power interruption.
- ▶ Guard locking may only be deactivated by the higher level safety controller once the hazardous machine movement has been completed.

- ▶ In a fault state, guard locking can be deactivated when die "Lock" LED lights up green. It cannot be reactivated in the fault state.

Active use of Safety Device Diagnostics

- ▶ After activation of guard locking is received from the controller, the safety inputs S31 and S41 must have a low signal within [t1] max. 500 ms.

Single connection

Guard locking is activated by a low signal at the safety inputs S31 and S41. A high signal at these safety inputs deactivates guard locking (power to unlock).

Series connection

In a series connection with n safety switches, guard locking is activated by a low signal with the safety inputs S31/S41 (solenoid activation). Guard locking is activated and safety outputs 12/22 are switched on after a delay. Please refer to the technical details (see Technical details) for the length of the delay.

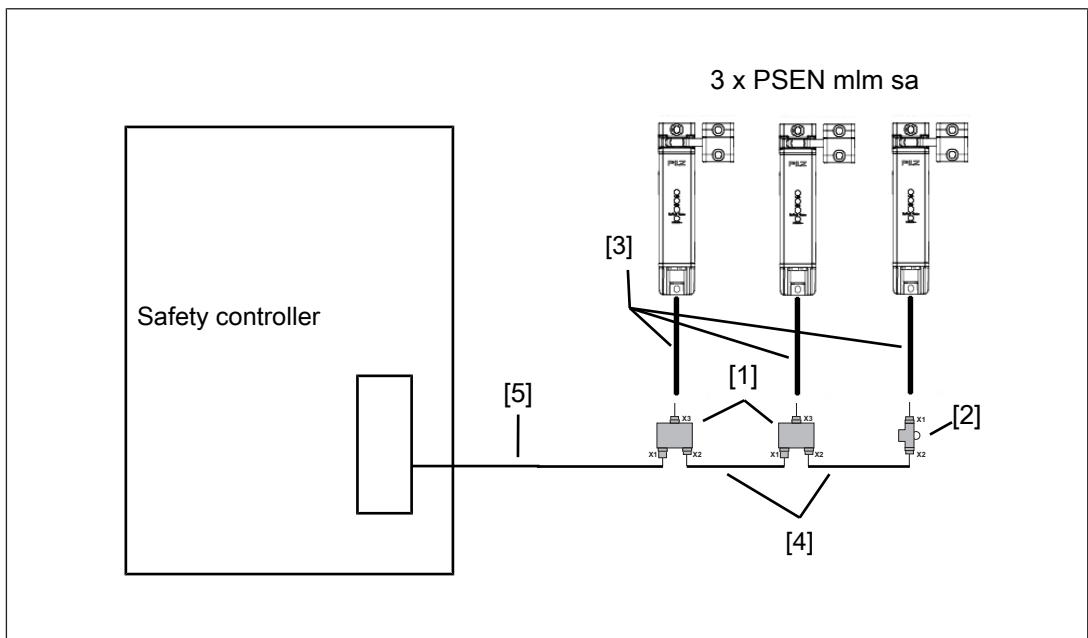

Legend

- [1] PSEN ml Y junction M12 (order number 570486)
 - [2] PSEN ml end adapter (order number 570 487)
 - [3] 12-core cable
PSEN cable M12-12sf M12-12sm (order number depends on the cable length)
 - [4] 8-core cable
PSEN cable M12-8sf M12-8sm (order number depends on the cable length)
 - [5] 8-core cable
PSEN cable M12-8sf (order number depends on the cable length)
- ▶ Series connection for diagnostics with Safety Device Diagnostics

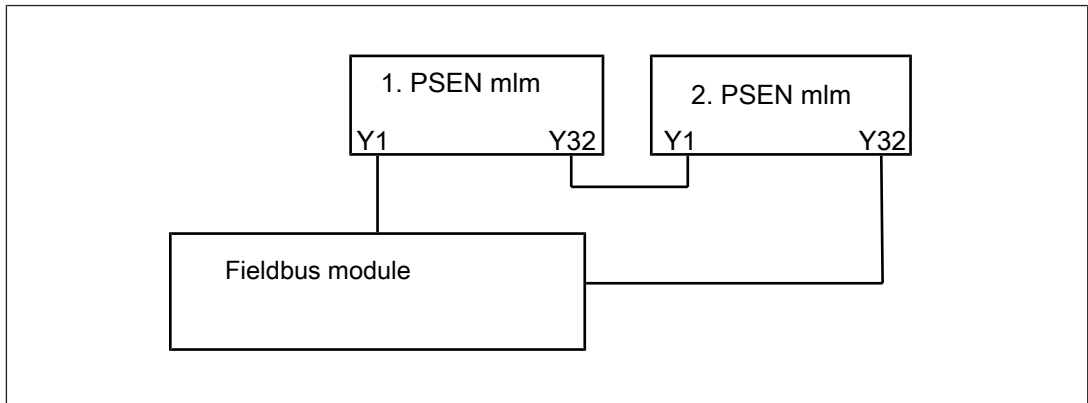

► Series connection for solenoid activation

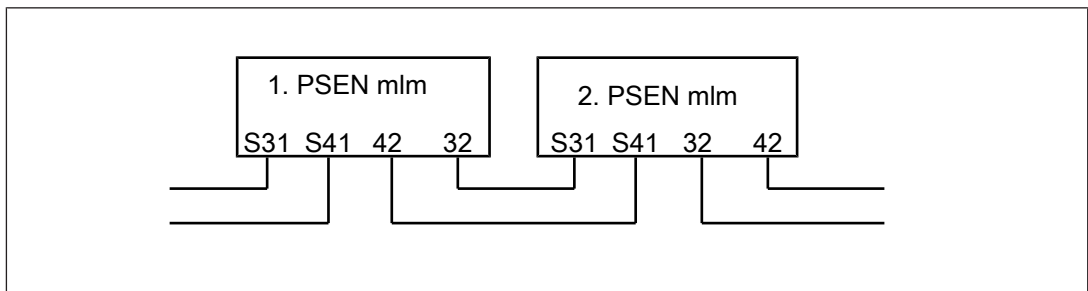

► Series connection for OSSD outputs

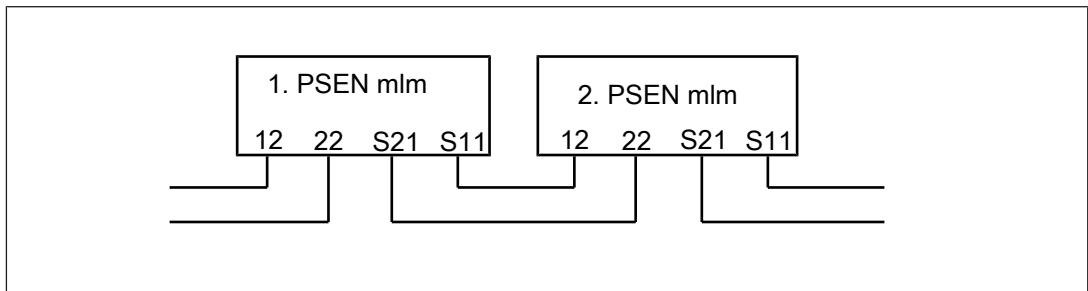

5.7 Safety Device Diagnostics

Safety Device Diagnostics is an option that can be selected independently of the safety-related wiring.

When using Safety Device Diagnostics, up to 16 sensors (of which max. 8 PSEN mlm) can be connected as subscribers to a fieldbus module.

The communication of the sensors with the fieldbus module is automatically built up again with each new supply of the supply voltage. As a result, a sensor can be exchanged, e.g. when servicing, without the need for special measures.

Any exchange can be detected via the fieldbus module, through the serial number for example.

- With Safety Device Diagnostics there are the following diagnostic options for the fieldbus module:
 - Poll information from the sensors (examples: what sensor in the series has switched, at what point could there be an open circuit in the series connection)
 - Read the sensors' configuration parameters (examples: number of teach-in processes remaining, switch's serial number)

- Perform actions (example: poll updated actuator name)
- Specifically deactivate guard locking on individual PSEN mlm devices in a series connection

The results of the sensor diagnostics can be checked already during the installation phase via the display in the fieldbus module, without the need to connect the fieldbus module to the network.

- ▶ Safety Device Diagnostics provide the following benefits for the fieldbus module when wiring:
 - Information is passed on via the fieldbus module directly to the network.
 - Any assignment of inputs/outputs of the fieldbus module to the sensors.
 - This prevents wiring errors and an expansion or reduction of the sensors is possible without the need to change existing wiring.
 - Wiring in accordance with IP20: Rapid installation in the control cabinet is enabled.
 - Wiring in accordance with IP67: Various passive junctions can be used (see [Order reference Accessories](#)  97) to connect several sensors with only one cable from the field in the control cabinet.

Further information on Safety Device Diagnostics can be found in [Additional documents that apply](#)  9).

5.8 Operating modes

The safety switch can be used in various operating modes.

- ▶ Operation without Safety Device Diagnostics
 - Standard operating mode
 - After every restart the safety switch is in operation without Safety Device Diagnostics.
 - No communication with Safety Device Diagnostics
 - Guard locking is activated/deactivated exclusively via safety inputs S31/S41.
- ▶ Operation with passive use of the Safety Device Diagnostics
 - Safety switch supplies diagnostic data to Safety Device Diagnostics
 - Guard locking is activated/deactivated exclusively via safety inputs S31/S41.
- ▶ Operation with active use of Safety Device Diagnostics
 - Guard locking is deactivated by a combination of a command from Safety Device Diagnostics and the state of safety inputs S31/S41 (S31/S41 must have a high signal).
The safety requirements are guaranteed by the signals at safety inputs S31/S41 (the fieldbus for Safety Device Diagnostics communication is not safety-related).

5.8.1 Operation without Safety Device Diagnostics

5.8.1.1 Timing diagram, case 1 (operation without Safety Device Diagnostics)

- ▶ [1] The safety gate is open. Diagnostic input Y1 is activated (high), the auxiliary release is not operated (low).
- ▶ [2] Safety inputs S11/S21 signal that guard locking has been activated successfully on the preceding device in the series connection (high).
- ▶ [3] The safety gate is closed, the diagnostic-/signal output Y32 signals that the safety gate is closed (high).
- ▶ [4] Guard locking is requested via safety inputs S31/S41. As soon as guard locking is safely secured, safety outputs 12/22 are activated (high).
- ▶ [5] The safety gate is now securely locked.
- ▶ [6] Execution of the hazardous machine function is now permitted.

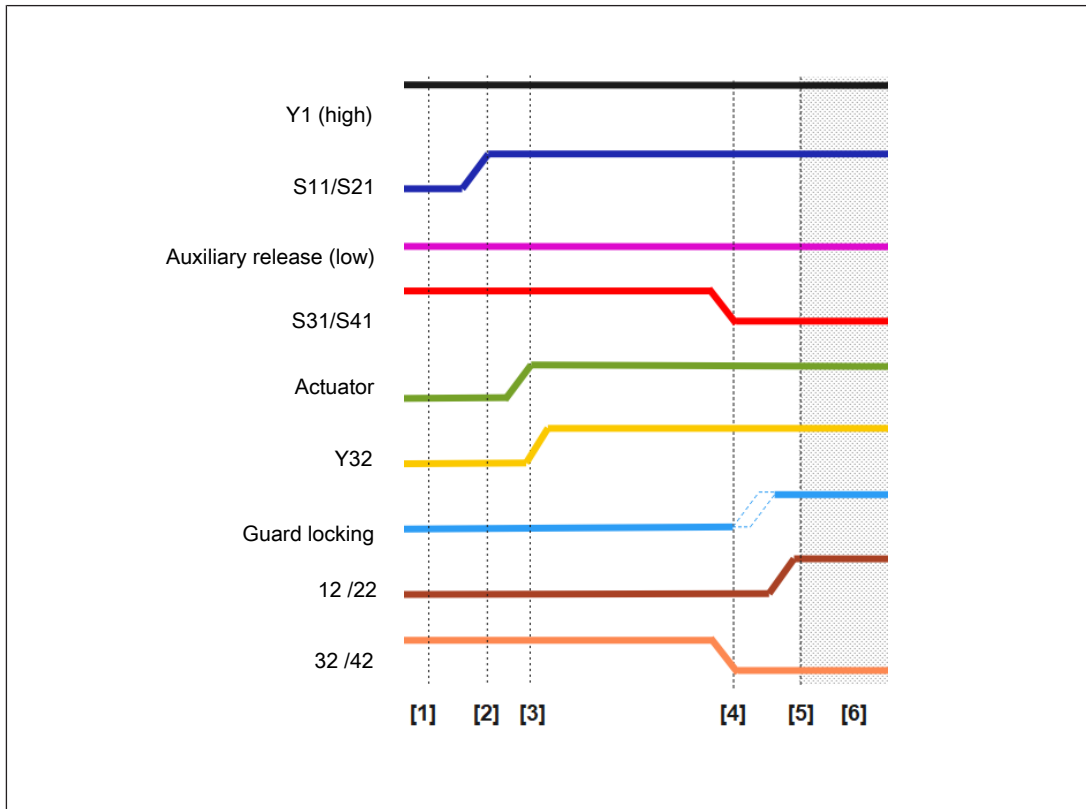

Fig.: Timing diagram, case 1

Legend

- [1] Safety gate open
- [2] Series connection input switches to high
- [3] Safety gate closed
- [4] Guard locking requested (by safety controller)
- [5] The safety gate is securely locked (guard locking is activated)
- [6] Execution of the hazardous machine function is permitted

5.8.1.2 Timing diagram, case 2 (automatic guard locking when closing the safety gate)

- ▶ The safety gate is closed and is securely locked. The hazardous machine function is executed.
- ▶ [1] Guard locking is deactivated via safety inputs S31/S41 (high). Safety outputs 12/22 are deactivated. (low).
- ▶ [2] The safety gate is opened, the diagnostic-/signal output Y32 signals that the safety gate is open (low).
- ▶ [3] Guard locking is requested via safety inputs S31/S41 (low).
- ▶ [4] The safety gate is closed again, the diagnostic-/signal output Y32 signals that the safety gate is closed (high). Guard locking is activated automatically.
- ▶ [5] As soon as guard locking is safely secured, safety outputs 12/22 are activated (high).
- ▶ [6] Execution of the hazardous machine function is once again permitted.

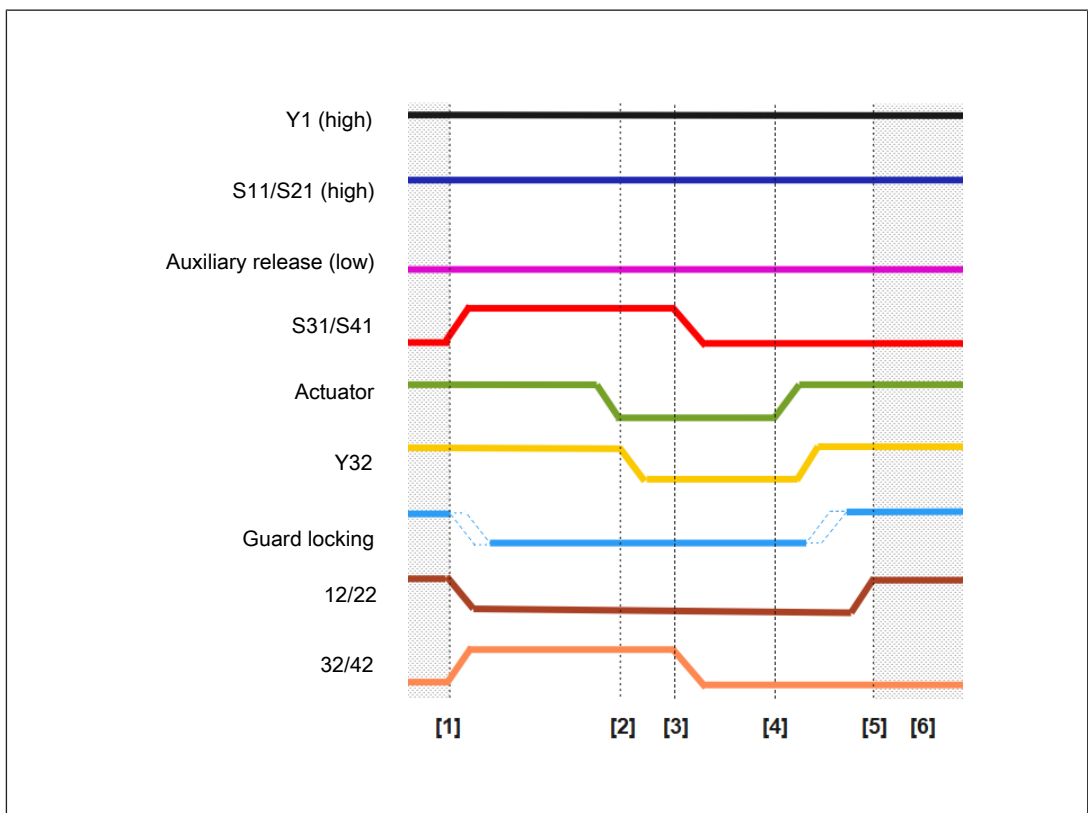

Fig.: Timing diagram, case 2

Legend

- [1] Deactivation of guard locking is requested (by safety controller)
- [2] Safety gate open
- [3] Safety gate guard locking is requested (by safety controller)
- [4] Guard locking is activated automatically when closing the gate (power to unlock)
- [5] The safety gate is securely locked (guard locking is activated)
- [6] Execution of the hazardous machine function is permitted

5.8.2 Operation with active use of Safety Diagnostics

- ▶ [1] The safety gate is closed and is securely locked. The hazardous machine function is executed. Safety inputs S11/S21 signal that guard locking has been activated successfully on the preceding device in the series connection (high). Diagnostic input Y1 is activated (high), the auxiliary release is not operated (low).
- ▶ [2] Deactivation of guard locking is requested via safety inputs S31/S41 (high).
- ▶ [3] Gate guard locking can now be deactivated with an SDD command.
- ▶ [4] The safety gate is opened.
- ▶ [5] Guard locking is requested via safety inputs S31/S41 (low).
- ▶ [6] The safety gate is closed again and guard locking is activated automatically, the guard locking signal switches to high.
- ▶ [7] As soon as guard locking is safely secured, safety outputs 12/22 are activated (high).
- ▶ [8] Execution of the hazardous machine function is once again permitted.

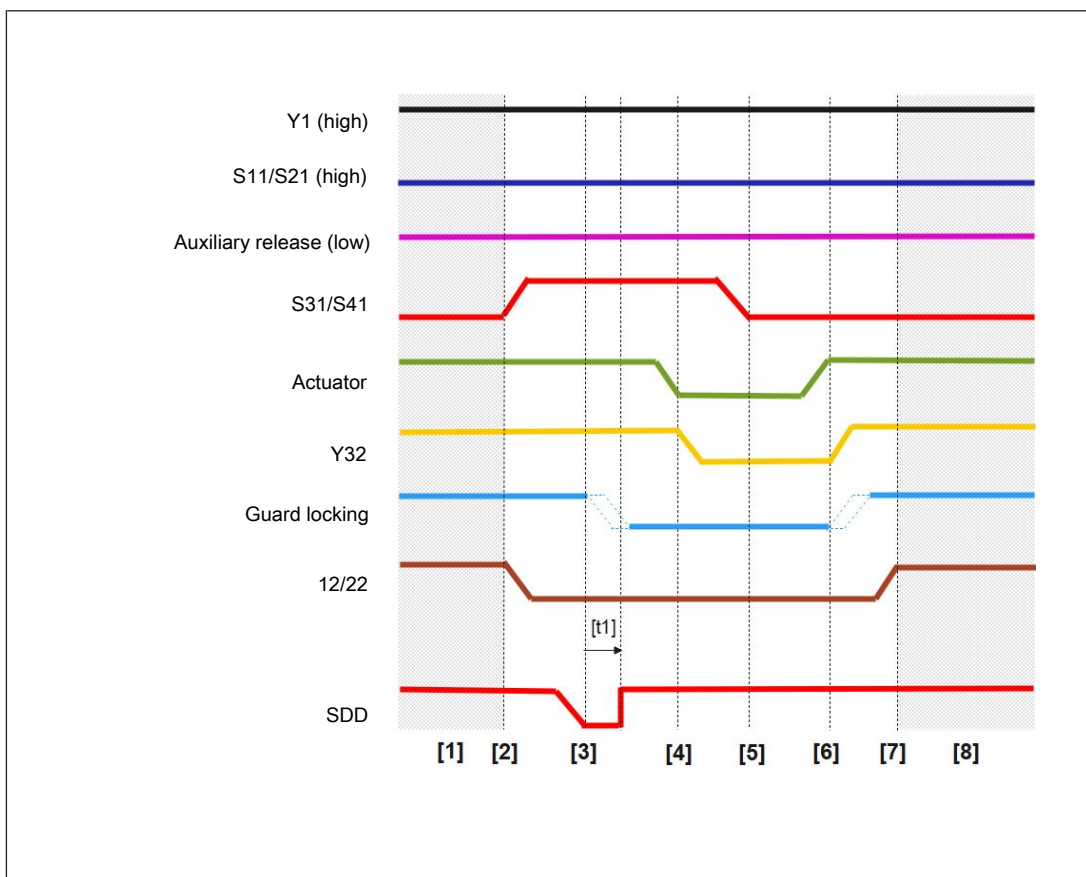

Fig.: Timing diagram: Operation with active use of Safety Device Diagnostics

Legend

- [1] Execution of the hazardous machine function is permitted
- [2] Deactivation of guard locking is requested (by safety controller)
- [3] Guard locking is deactivated via SDD guard locking command (not safety-related)
- [4] Safety gate open
- [5] Safety gate guard locking requested (by safety controller)

- [6] Safety gate closed
- [7] Guard locking is activated automatically by closing the gate
- [8] Execution of the hazardous machine function is permitted
- [t1] Validity time for SDD command, the latest time within which guard locking must be deactivated via S31/S41

5.9 Block diagram

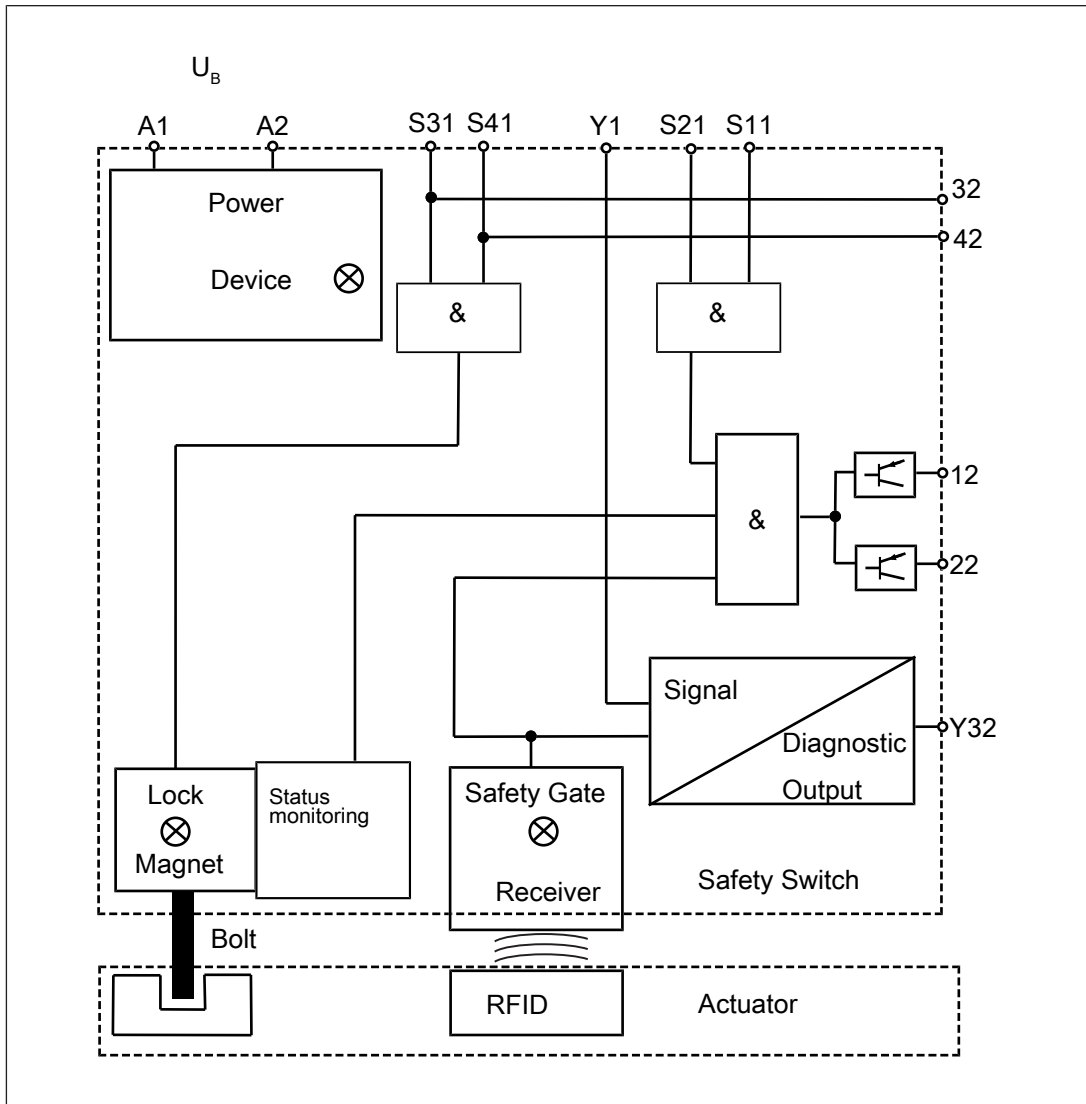

Fig.:

Legend

- [U_B] Supply Voltage
A1: +24 V
A2: 0 V
- [S31], [S41] Safety inputs
Activation of solenoid to open and close guard locking
- [Y1] Diagnostic input

[S21], [S11]	Safety inputs (see Series connection)
[32], [42]	Safety outputs for activating the solenoid on the next safety switch in the series connection (see Series connection)
[12], [22]	Safety outputs
[Y32]	Signal/diagnostic output

5.10 Auxiliary release

The auxiliary release enables guard locking to be opened from the access side to the danger zone.



NOTICE

The auxiliary release may only be operated once the machine is at standstill.

The safety switch has auxiliary releases on two opposite sides.

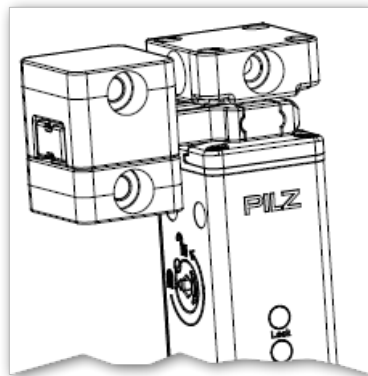

Auxiliary release
PSEN mlm with actuator a

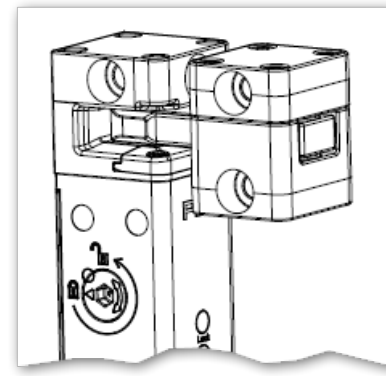

Auxiliary release
PSEN mlm with actuator b



INFORMATION

If guard locking is deactivated using the auxiliary release, there is a low signal at safety outputs 12 and 22. A warning will be output (see chapter [Operation \[67\]](#)). The safety switch does **not** switch to the fault condition.

It is possible to open guard locking using the control system.



NOTICE

The auxiliary release does not represent a safety function. The operator is responsible for using an appropriate auxiliary release, depending on the specific application. A hazard assessment can be carried out as an option, and specifications from the product standard must be adhered to. The functionality of the auxiliary release should be checked regularly.

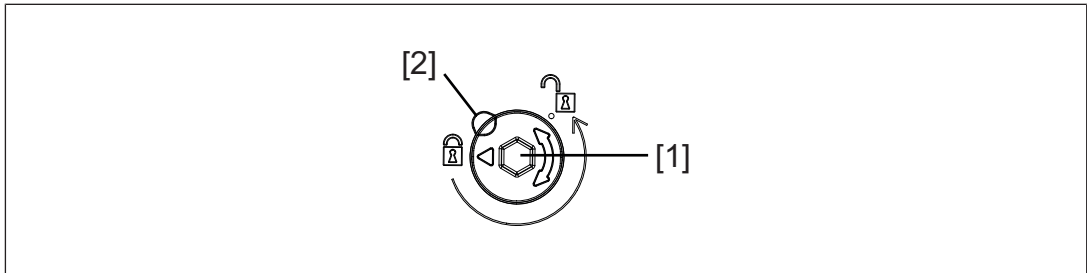

Fig.: Auxiliary release

Legend

- [1] Auxiliary release screw, hexagon socket with wrench size 4 (SW4)
- [2] Marked area for locking varnish (supplied without locking varnish)

Operating principle

1. Using an Allen key (SW4), rotate the auxiliary release screw [1] as far as it will go in the direction of the arrow (max. 230°). The guard locking pin is displaced and the bolt is released. The safety gate to the danger zone can be opened.

5.10.1 Recommissioning

Recommission the safety switch

1. Using an Allen key (SW4), rotate the auxiliary release screw [1] (see [diagram \[26\]](#)) as far as it will go in the opposite direction to the arrow (max. 230°).
2. Use varnish to seal the marked area/indent [2] (see [diagram \[26\]](#)).
3. Carry out a function test on the safety switch and actuator. The safety function may only be checked by qualified personnel.



INFORMATION

If the auxiliary release screw is not turned back correctly after use, guard locking cannot be activated/deactivated.



NOTICE

Once the auxiliary release has been operated, guard locking cannot be re-activated until

- the safety gates have been opened and then closed again or
- S31/S41 have been switched on and then off again.

6 Wiring

6.1 Important information

- ▶ Information given in the [Technical details \[75\]](#) must be followed.
- ▶ Ensure that the connection cable is disconnected from the power supply when it is plugged into the safety switch.

6.2 Pin assignment, connector and cable



NOTICE

The colour marking for the connection lead only applies for the cable that Pilz supplies as an accessory.

	8-pin M12 connector
--	---------------------

PIN	Function	Terminal designation	Cable colour (Pilz cable)
1	Operation of solenoid to open and close guard locking (channel 2)	S41	white
2	+24 V UB	A1	Brown
3	Safety output channel 1	12	Green
4	Safety output channel 2	22	Yellow
5	Signal output/diagnostic output	Y32	grey
6	Operation of solenoid to open and close guard locking (channel 1)	S31	Pink
7	0 V UB	A2	Blue
8	Diagnostics input	Y1	Red

	12-pin M12 male connector
--	---------------------------

PIN	Function	Terminal designation	Cable colour (Pilz cable)
1	+24 V UB	A1	Brown
2	0 V UB	A2	Blue
3	Operation of solenoid to open and close guard locking (channel 2)	S41	White
4	Safety output channel 1	12	Green
5	Operation of solenoid to open and close guard locking (channel 1)	S31	Pink
6	Safety output channel 2	22	Yellow
7	Safety input channel 1	S11	Black
8	Signal output/diagnostic output	Y32	Grey
9	Diagnostics input	Y1	Red
10	Safety input channel 2	S21	Purple
11	Operation of solenoid of the next safety switch in the series connection (channel 1)	32	Grey-pink
12	Operation of solenoid of the next safety switch in the series connection (channel 2)	42	Red-blue

**NOTICE**

Fasten the connection cable with a torque of 0.6 Nm.

6.3**EMC requirements and electrical safety**

- ▶ Ensure the wiring and EMC requirements of EN 60204-1 are met.
- ▶ UL requirement: The supply voltage to the safety switch must be protected with a quick-acting fuse (see [Technical details \[75\]](#)).
- ▶ The power supply and the components connected to the PSEN mIm must meet the regulations for extra low voltages with protective electrical separation (SELV, PELV).
- ▶ The power supply must have an overvoltage protection of ≤ 35 VDC.

**INFORMATION**

Only use safety relays with a 24 VDC supply voltage. Safety relays with a wide-range power supply or in AC device versions have internal potential isolation and are not suitable as evaluation devices.

7 Connection to control systems and evaluation devices

7.1 Important information

The selected evaluation device must have the following properties:

- ▶ Dual-channel with plausibility monitoring

Both OSSDs must change the switch state synchronously. In particular, the evaluation device must monitor that the state of both OSSDs was "Gate unlocked" before both return to the "Gate locked" state and vice-versa.

- ▶ OSSD signals have dual-channel evaluation.
- ▶ The use of Safety Device Diagnostics is described in detail in the Safety Device Diagnostics System Description (1003827).



WARNING!

Hazard due to loss of the safety function

Depending on the application, serious injury or death may result. The safety function can be lost when the safe state is not checked regularly.

- Use an evaluation device/safety system to test whether the plant is in a safe condition.
- Do not operate the solenoid via S31/S41 unless the plant is in a safe condition.

7.2 Minimum requirements for activation of guard locking

Use in PL d (Cat. 3) applications

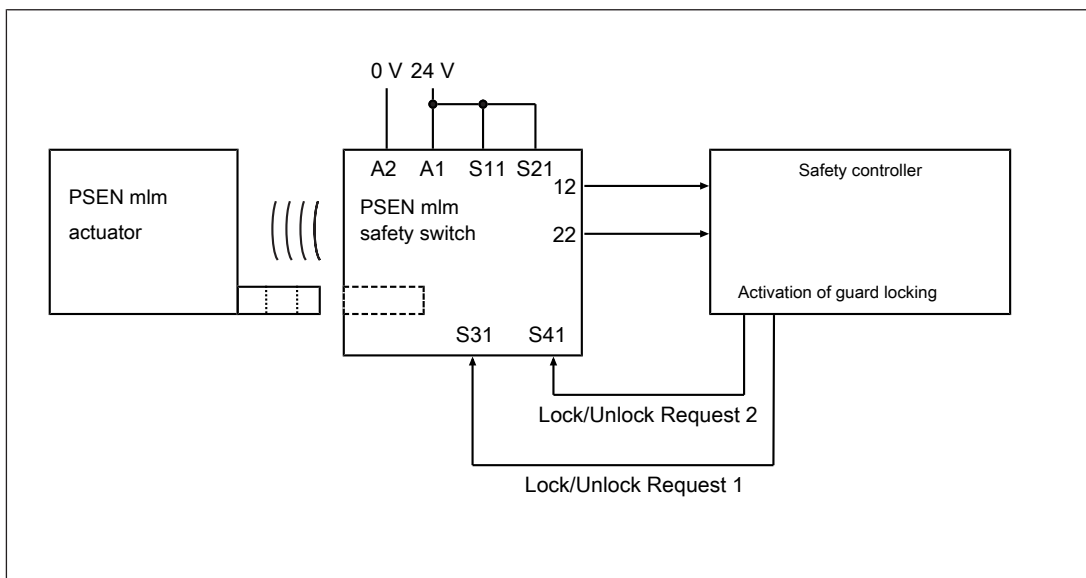
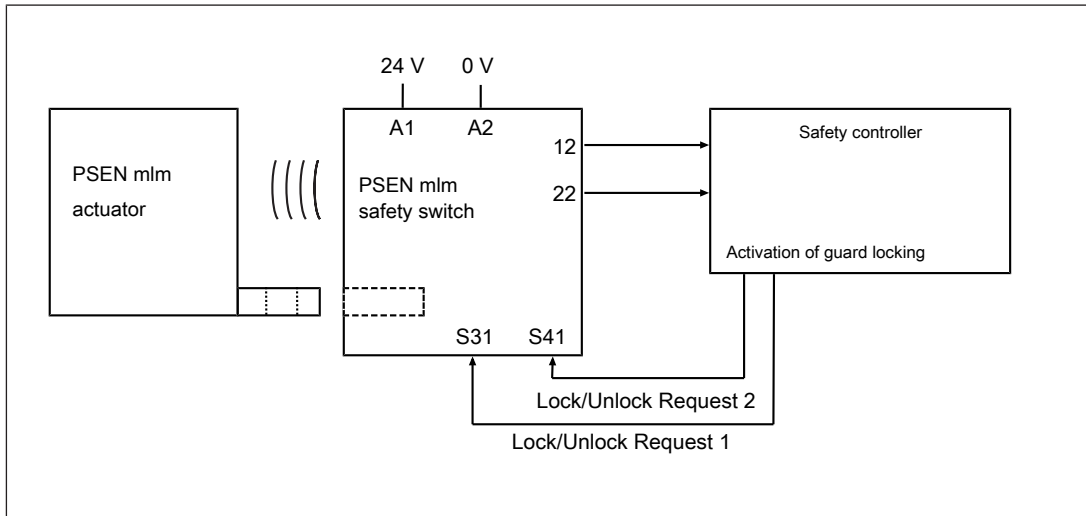

- ▶ Safety inputs S31 and S41 (solenoid activation) have 2-channel operation via safe outputs, which are suitable for PL d (Cat. 3) applications
- ▶ Use 2-channel operation for safety inputs S31 and S41 (solenoid activation)
- ▶ Use 2-channel processing for safety outputs (12 and 22)

Use in PL d (Cat. 2) applications

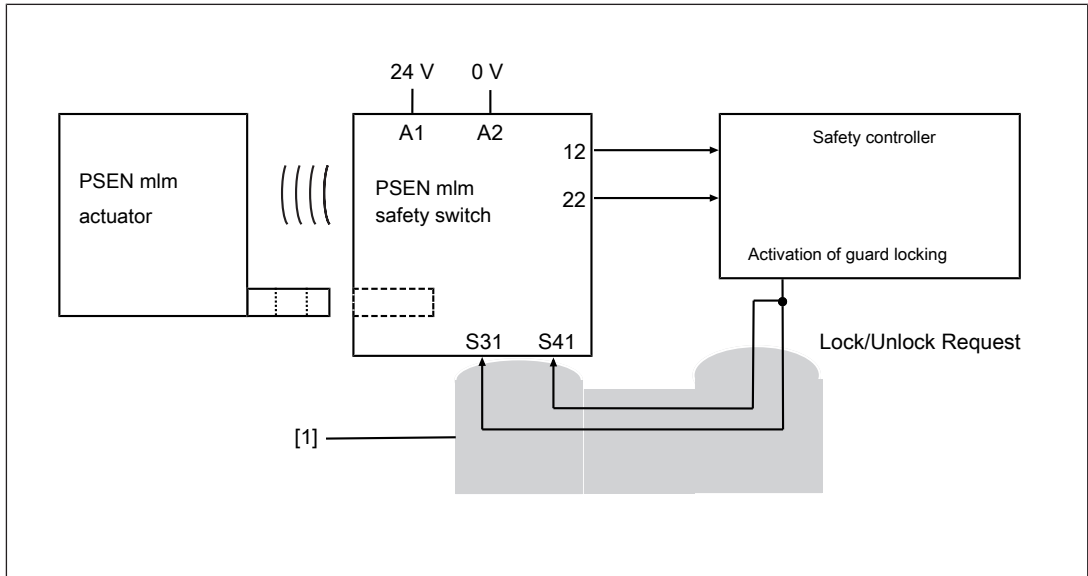

Legend

[1] Protected cable layout



WARNING!

Hazard due to loss of the safety function

Serious or fatal injury could result, depending on the application. Shorts across the signal cable can cause the safety inputs to activate and lead to the loss of the safety function.

- Exclude shorts through appropriate measures (e.g. protected cable layout, see EN ISO 13849-2).

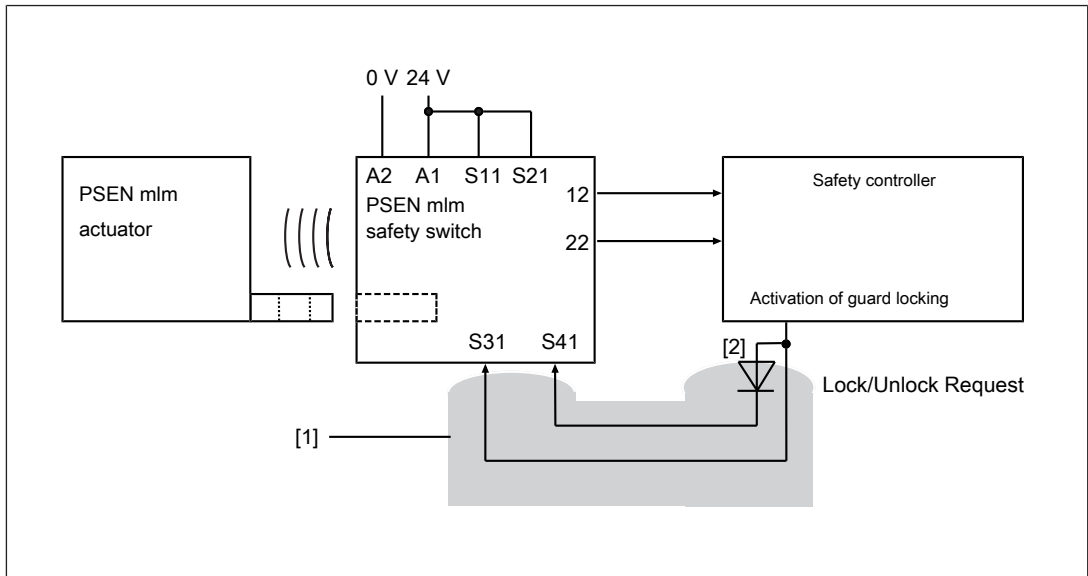

Legend

- [1] Protected cable layout
- [2] With a series connection of 2 to 8 safety switches, the total cable length is reduced (see Series connection, examples for cable lengths). This reduction can be avoided by installing a diode.

Diode (optional) to prevent the reduction of the maximum total cable length: Terminal Block Filter (order number: 772290, 772291, see order references for Accessories)

Connection instructions for Terminal Block Filter

Use only the IN and OUT connections (0 V does not need to be connected).

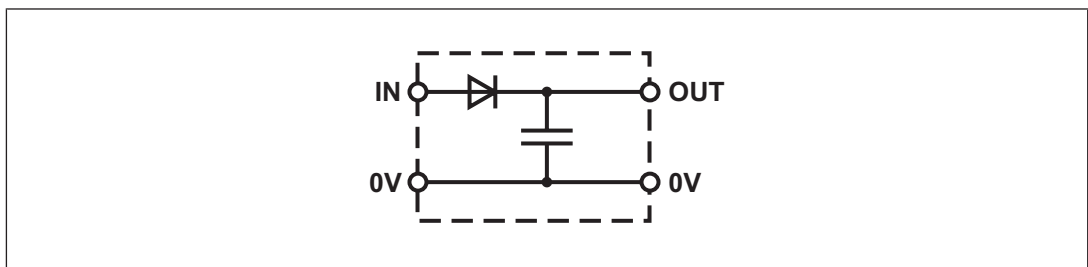

Fig.: Block diagram for Terminal Block Filter



WARNING!

Hazard due to loss of the safety function

Serious or fatal injury could result, depending on the application. Shorts across the signal cable can cause the safety inputs to activate and lead to the loss of the safety function.

- Exclude shorts through appropriate measures (e.g. protected cable layout, see EN ISO 13849-2).

- ▶ 1-channel operation for safety inputs S31 and S41 (solenoid operation) via safe outputs
- ▶ Use 2-channel processing for safety outputs (12 and 22)
- ▶ Use 1-channel operation for interconnected safety inputs S31 and S41 (solenoid activation)
- ▶ Exclusion of shorts across signal cables through appropriate measures (e.g. protected cable layout, see EN ISO 13849-2).

7.3 Single connection

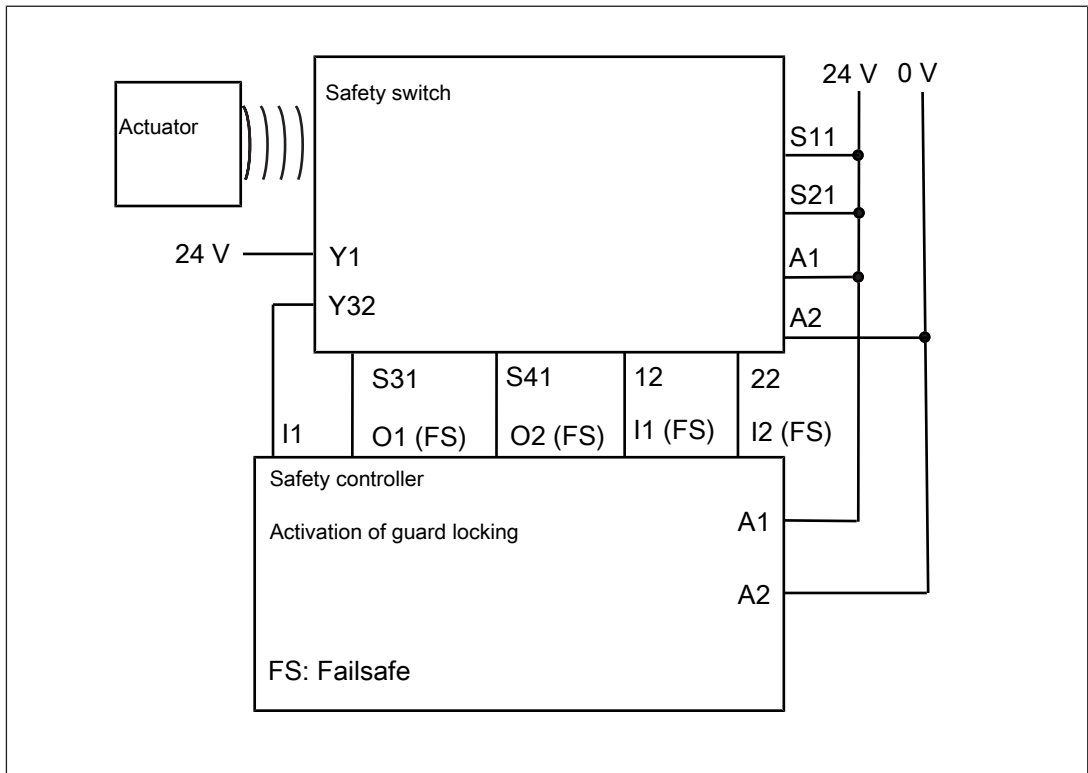

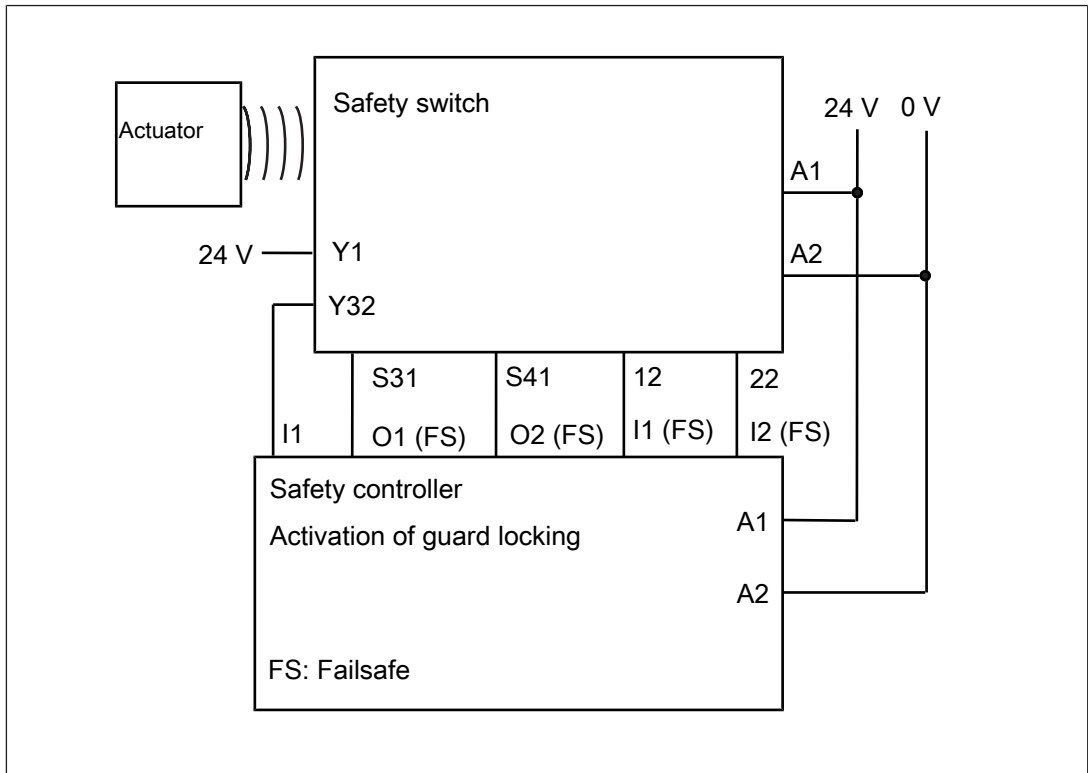

7.4 Series connection



NOTICE

Extension of delay-on de-energisation

When several (n) devices are connected in series, the delay-on de-energisation time is multiplied by the number of interconnected safety switches. The max. delay-on de-energisation is made up of the risk time (see [Technical details \[75\]](#))
 + (n-1) x max. delay-on de-energisation of the safety inputs
 + max. delay-on de-energisation of the evaluation device.



NOTICE

Increased current at the solenoid input

When several (n) devices are connected in series, the input current is multiplied by the number of safety switches connected in series (see [Technical details \[75\]](#)).

Up to 8 safety switches can be connected in series.

In practice, the maximum possible number will be limited by the following parameters, among others:

- ▶ The required performance level (e.g. PL d (Cat. 3)),
- ▶ The maximum delay or risk time permitted by the application,
- ▶ Cable length (see notes on cable lengths),
- ▶ Height of supply voltage.

Ensure there is sufficient supply voltage, taking inrush currents and fusing into consideration.

Notes on cable lengths

- ▶ The values are determined values under the following conditions:

Room temperature (25°C)

Cable cross section 0.25 mm²

With the output current per output (12, 22, Y32), it is presumed that this need only be supplied by one device. All the others are loaded with the input current from downstream safety switches, which is already included in the total current.

The devices are spread over the total cable length (in this case: an example with 6 safety switches).

The total cable length is the distance to the furthest device. Stub lines from Y-adapters to less distant devices are not taken into consideration.

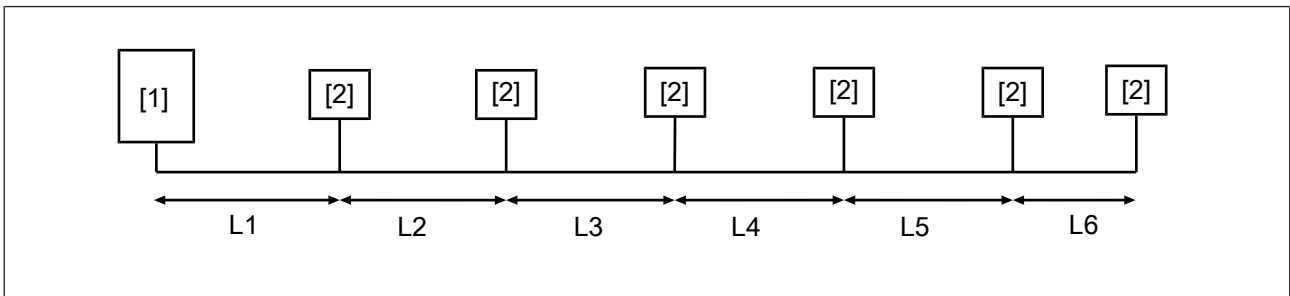

Legend

- [1] Safety controller
- [2] Safety switch PSEN mIm

Examples for cable lengths

Use in PL d (Cat. 3) applications (see [Minimum requirements for activation of guard locking \[32\]](#))
2-channel application
Series connection of 1 to 8 safety switches

Supply voltage at the safety controller = 24.0 V		Supply voltage at the safety controller = 28.8 V	
Number of safety switches	Total cable runs	Number of safety switches	Total cable runs
1	45 m	1	78 m
2 ... 4	36 m	2 ... 4	64 m
5 ... 6	33 m	5 ... 6	60 m
7 ... 8	30 m	7 ... 8	55 m

Use in PL d (Cat. 2) applications (see [Minimum requirements for activation of guard locking \[32\]](#))
1-channel application
Series connection of 1 to 8 safety switches

Supply voltage at the safety controller = 24.0 V		Supply voltage at the safety controller = 28.8 V	
Number of safety switches	Total cable length(*)	Number of safety switches	Total cable length(*)
1	45 m	1	78 m
2 ... 4	36 m	2 ... 4	64 m
5 ... 6	33 m	5 ... 6	60 m
7 ... 8	30 m	7 ... 8	55 m

(*) The reduction of the total cable length can be avoided by installing a diode when connecting S41 in the control cabinet (see [Minimum requirements for activation of guard locking \[32\]](#), "Use in PL d (Cat. 2) applications").

Connecting the safety switches in a series connection

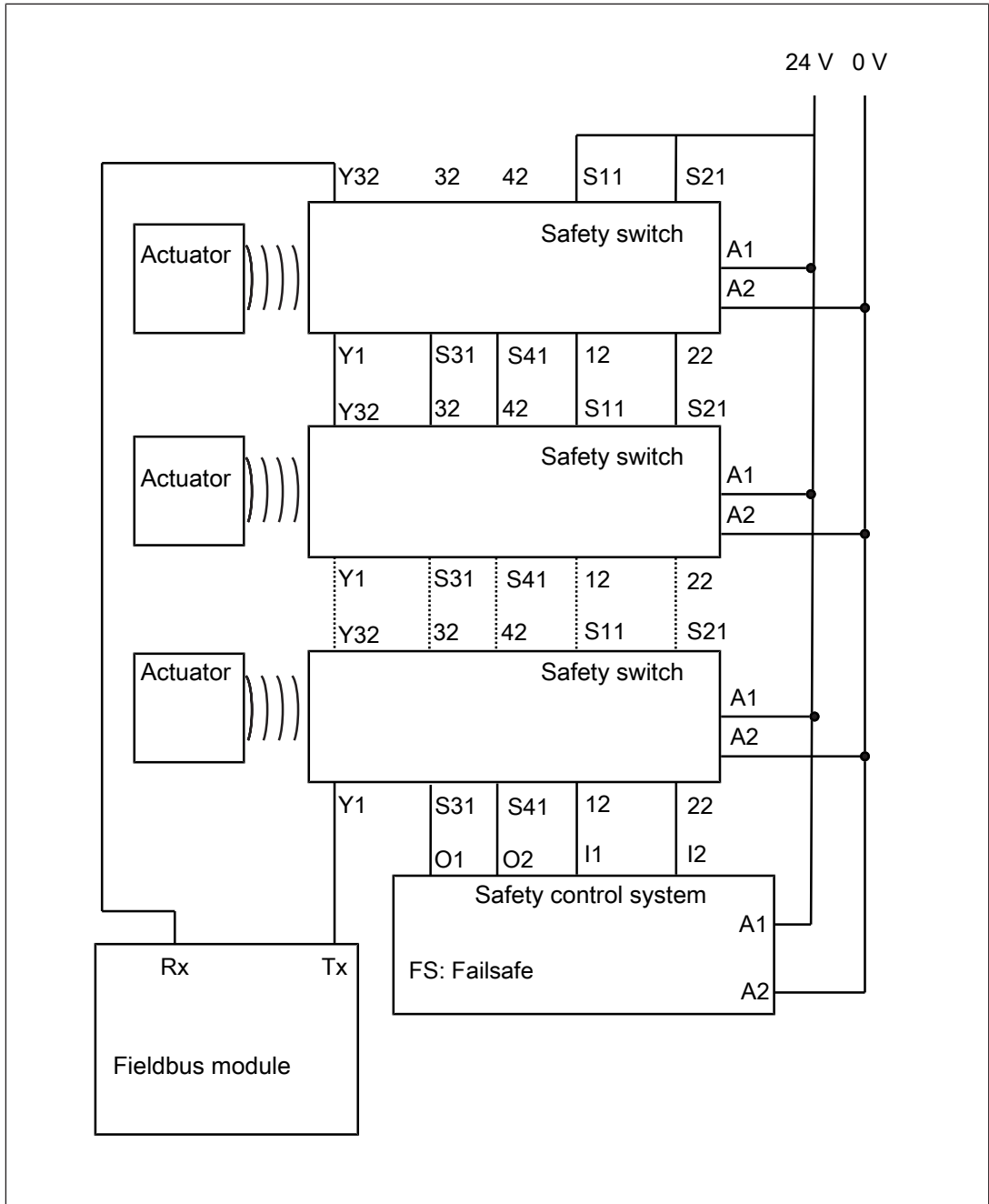

The following options are available for connecting the safety switch in a series connection:
Wiring to the safety controller via PSEN ml Y junction

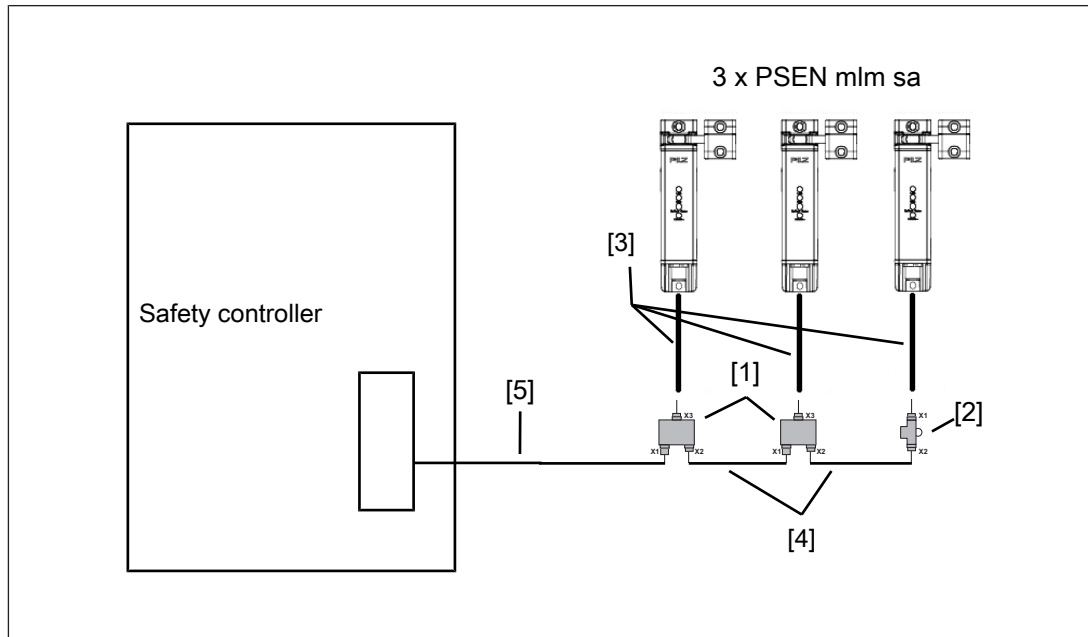

Legend

- [1] PSEN ml Y junction M12 (order number 570486)
 - [2] PSEN ml end adapter (order number 570487)
 - [3] 12-core cable
PSEN cable M12-12sf M12-12sm (order number depends on the cable length)
 - [4] 8-core cable
PSEN cable M12-8sf M12-8sm (order number depends on the cable length)
 - [5] 8-core cable
PSEN cable M12-8sf (order number depends on the cable length)
- When establishing the series connections that connect to the safety controller, use the following adapters and cables:
- PSEN ml Y junction M12
 - PSEN ml end adapter
 - PSEN cable M12-12sf M12-12sm
 - PSEN cable M12-8sf M12-8sm
- Connection in the control cabinet at the terminal block
- Connect a 12-core cable (for example PSEN cable M12-12sf M12-12sm) to the safety switch and guide it to the terminal block in the control cabinet.



NOTICE

Before commissioning, check the [Series connection of the safety channels](#) [ 70].

Calculation of currents when safety switches are connected in series

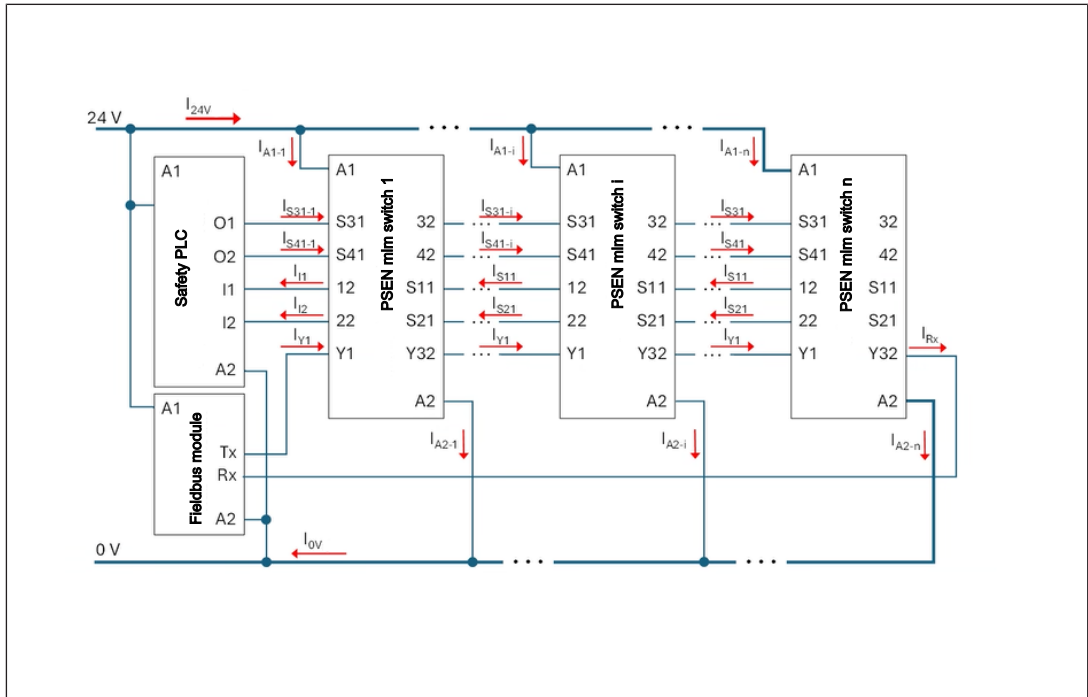

Fig.: Currents when safety switches are connected in series

$$I_{A1-1} = I_0 + I_{I1} + I_{I2} + I_{Y1} + I_{Magnet}$$

$$I_{A1-i} = I_0 + I_{S11} + I_{S21} + I_{Y1} + I_{Magnet}$$

$$I_{A1-n} = I_0 + I_{S11} + I_{S21} + I_{Rx} + I_{Magnet}$$

$$I_{A2-1} = I_0 + I_{S11} + I_{S21} + I_{S31} + I_{S41} + I_{Y1} + I_{Magnet}$$

$$I_{A2-i} = I_{A2-1}$$

$$I_{A2-n} = I_0 + I_{S31} + I_{S41} + I_{Y1} + I_{Magnet}$$

Legend

I_0 = Idle mode, 20 mA, (see [Technical details \[75\]](#))

$i = 2, \dots, n - 1$

$I_{S11}, I_{S21}, I_{Y1} = 2.6$ mA, input current range, (see [Technical details \[75\]](#))

$I_{S31} = I_{S41} = 4$ mA, current at solenoid input (see [Technical details \[75\]](#))

$I_{Magnet} = 1.15$ A, max. solenoid current $t < 150$ ms supplied via A1 (see [Technical details \[75\]](#))

I_{I1}, I_i : see operating manual for safety controller

I_{Rx} : see operating manual for fieldbus module

7.5 Supplement to series connection

Table 8 of standard EN 61131-2, Type 3, defines the following for the switching threshold of the inputs and outputs:

Low: $\leq 5\text{ V}$

High: $\geq 11\text{ V}$

To connect longer cable lengths and/or more than 8 safety switches in series, select the following wiring:

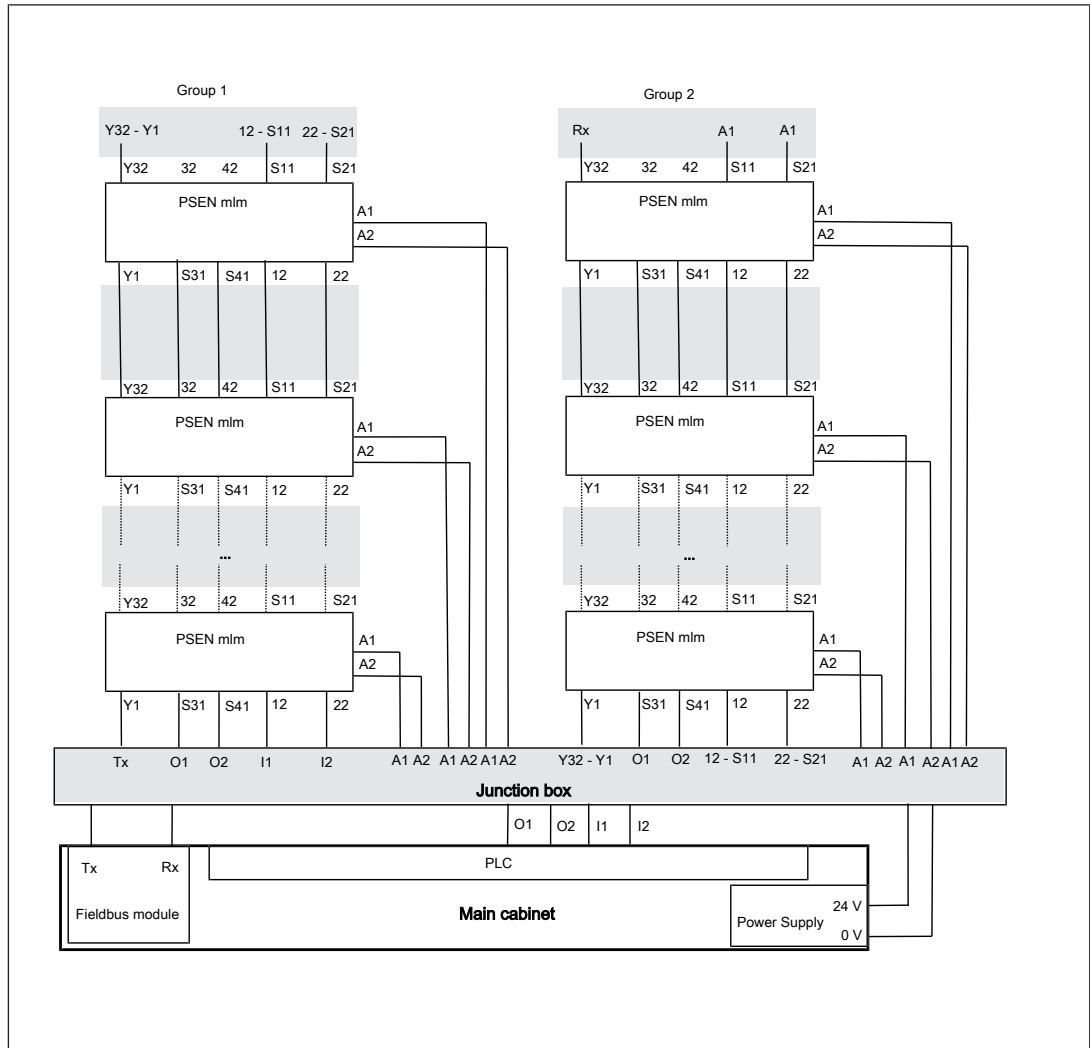

Fig.: Example with more than 8 safety switches connected in series

In the illustration above the connections with grey backgrounds are connected to the junction box. As a result, wiring various PSEN m1m is possible. The junction box is not an accessory from Pilz.

Please note the following:

- ▶ If more than 8 safety switches are connected in series, we recommend that you form groups for series connection of the solenoid control 32, 42, S31 and S41, as shown in the table below. When switching for $< 1\text{ s}$, the required current increases to the value stated in the table.

- ▶ The outputs and inputs 12, 22, S11 and S21 of the devices in all groups can be connected in series.
- ▶ With a wire cross-section of $\geq 1.5 \text{ mm}^2$, protect the power supply cable to the junction box with an 8 A fuse.
- ▶ While the safety switch is switching, the supply voltage may drop to 16.5 V.
- ▶ The voltage drop from solenoid input S41 to output 42 is typically 0.5 V. The voltage drop on the S41 line must also be taken into account. Ensure that the voltage at solenoid input S41 on the final safety switch is at least 11 V for high signals.
- ▶ In SDD mode, diagnostic inputs Y1 and diagnostic outputs Y32 from a maximum of 16 safety switches can be connected in series. When operating as a signal output, this restriction does not apply.
- ▶ The PFH_D value (see [Safety-related characteristic data \[94\]](#)) for guard locking is calculated for up to a maximum of 8 safety switches connected in series. Where 9...16 safety switches are connected in series, the value stated in the safety-related characteristic data is doubled. Where 17...20 safety switches are connected in series, the value stated in the safety-related characteristic data is trebled.
- ▶ With a series connection, a delay-on de-energisation of 5 ms for each additional safety switch must be taken into account for interlocking (see [Technical details \[75\]](#)).
- ▶ The supply voltage for each group of safety switches (connected in series) must be protected with a fuse (see [Technical details \[75\]](#)).
- ▶ The time stated in the [Technical details \[75\]](#) under "Activate/deactivate guard locking processing time" is irrespective of the number of devices.

Table for group formation with series connection

Number of safety switches	Number of safety switches Group 1	Number of safety switches Group 2	Number of safety switches Group 3	Total current in A when switching
1	1			1.1
2	2			1.4
3	3			
4	4			
5	5			1.5
6	6			1.6
7	7			
8	8			1.7
9	6	3		2.8
10	6	4		
11	6	5		3.0
12	6	6		
13	7	6		3.1
14	7	7		

Number of safety switches	Number of safety switches Group 1	Number of safety switches Group 2	Number of safety switches Group 3	Total current in A when switching
15	8	7		3.2
16	6	6	4	4.3
17	6	6	5	4.4
18	6	6	6	
19	7	6	6	4.5
20	7	7	6	4.6

7.6 Connection to Pilz evaluation devices

The safety switch can be connected to Pilz evaluation devices.

Suitable Pilz evaluation devices are, for example:

- ▶ PNOZmulti for safety gate monitoring
Configure the switch in the PNOZmulti Configurator with switch type 3.
- ▶ PSSuniversal PLC for safety gate monitoring with function block FS_SafetyGate

The correct connection to the respective evaluation device is described in the operating manual for the evaluation device. Make sure that the connection is made in accordance with the specifications in the operating manual for the selected evaluation device.

Connection to PNOZmulti is illustrated by way of example.

Connection example with PNOZmulti and Safety Device Diagnostics (SDD)

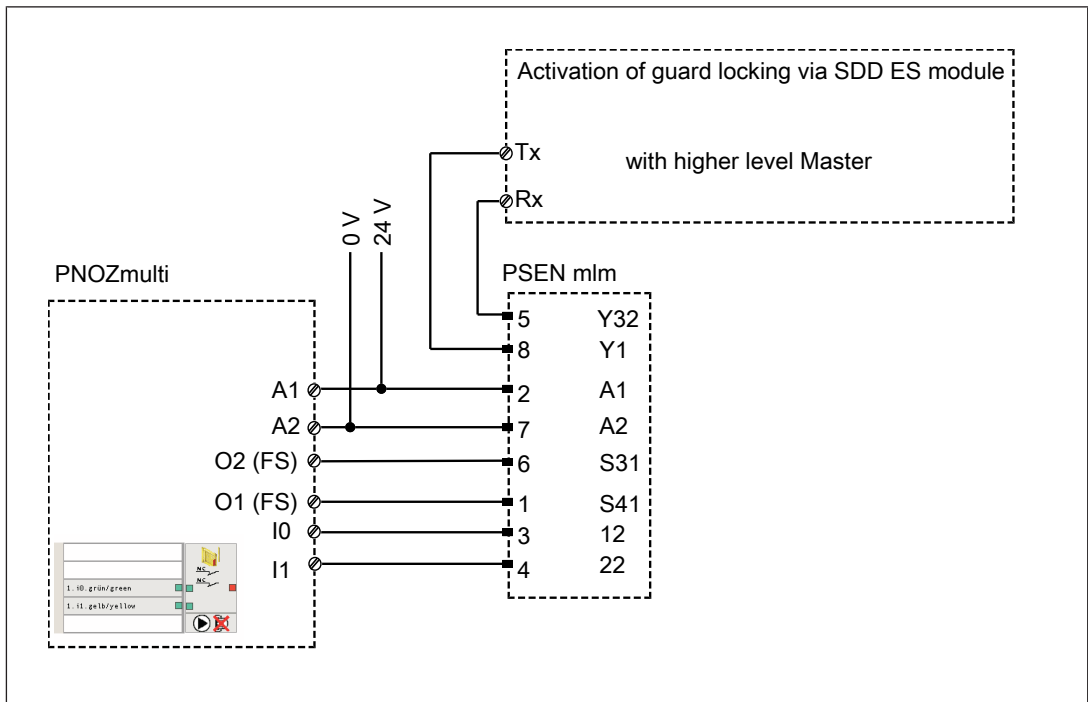

Connection example with PNOZmulti and Safety Device Diagnostics (SDD)

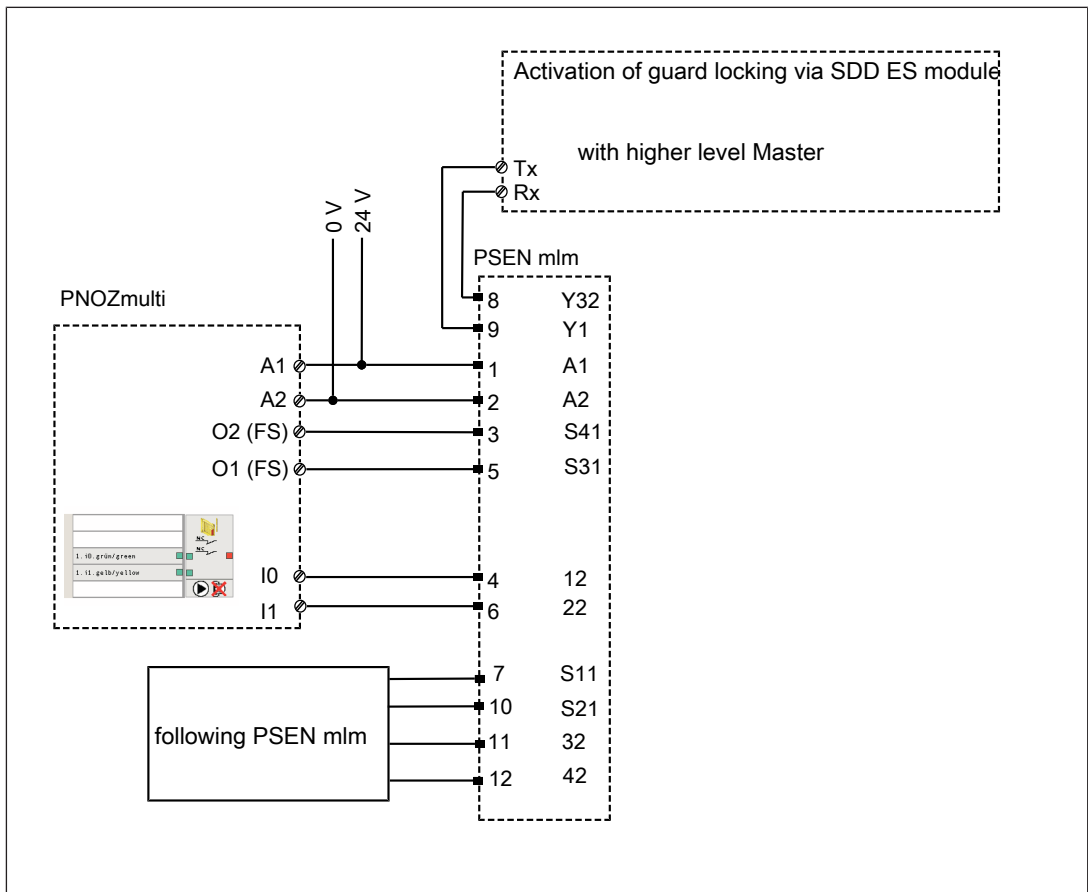

8 Teaching in the actuator

A distinction is made between the following Pilz coding types:

Coded	The safety switch PSEN mlm x sa 1.1 switch accepts any PSEN mlm actuator.
Fully-coded	The safety switch PSEN mlm x sa 2.1 switch accepts only one PSEN mlm actuator. A maximum of 8 learning procedures are possible for that one actuator.
Uniquely coded	The safety switch PSEN mlm x sa 2.2 switch accepts only one PSEN mlm actuator. Only one learning procedure is possible for that one actuator.

PSEN mlm x sa 1.1

Any corresponding Pilz actuator (see [Technical Details \[75\]](#)) is detected as soon as it is brought into the response range.

The response range is achieved when the actuator is inserted into the safety switch.

PSEN mlm x sa 2.1

Teaching in the actuator for the first time:

The first actuator to be detected by the safety switch (see [Technical details \[75\]](#)) is taught in automatically as soon as it is brought into the response range.

To teach in a new actuator:

- ▶ A maximum of 8 learning procedures are possible.
1. The actuator that is to be taught in must be brought into the safety switch's response range as the only transponder. As soon as the actuator is detected, the "Safety Gate" LED will flash yellow.
 2. After a waiting period of 20 s, the "Safety Gate" LED has the following status: yellow, flashes quickly. Trigger a system reset in the next 120 s by interrupting the supply voltage.
 3. When the supply voltage is switched back on, the learning procedure is complete and the number of permitted additional learning procedures is reduced by 1.



NOTICE

- The actuator must not be removed during the learning procedure.
- It is no longer possible to reteach this actuator on the same safety switch.

PSEN mIm x sa 2.2

The **first** actuator to be detected by the safety switch (see [Technical details \[75\]](#)) is taught in automatically as soon as it is brought into the response range.

The safety gate LEDs light up a constant yellow when the actuator is detected (see [Normal operation \[67\]](#)).



NOTICE

No other actuator may be taught in once this actuator has been taught.

9 Installation

9.1 Important information





NOTICE

Install the safety switch and actuator so that the possibilities of defeat are reduced to a minimum (see guidelines for reducing the possibilities for defeating interlocking devices in EN ISO 14119).



NOTICE

Install safety switch and actuator so that it is not possible to reach through with hand or finger.

- ▶ Prevent anyone from becoming trapped unintentionally in the danger zone. The safety switch does not have an emergency release.
- ▶ The fastening of safety switch and actuator has to be sufficiently stable to ensure the proper operation of the safety switch and the actuator.
- ▶ Prevent the safety switch and actuator being exposed to heavy shock or vibration.
- ▶ The mounting surfaces for safety switches and actuators can have a max. unevenness of 0.5 mm.
- ▶ The actuator must rest flush on the mounting surface.
- ▶ The safety switch and actuator should be installed opposite each other in parallel.
- ▶ Once installed, it must be possible to operate at least one of the auxiliary releases.
- ▶ Use the same type of screw to attach the safety switch and actuator.
- ▶ Use non-removable flat head locking screws to attach the safety switch and actuator (e.g. cheese-head or pan head screws) or rivets.
- ▶ Use M5 screws with a min. resistance class of 8.8 to attach the safety switch and actuator, and ensure that a minimum screw depth of ≥ 7 mm is achieved.
- ▶ The fastening elements must be prevented from coming loose,
 - on the safety switch: by complying with the max. torque setting (see [Technical details](#)  75]) and medium strength threadlocking adhesive.
 - on the actuator: by complying with the max. torque setting (see [Technical details](#)  75]) and medium strength threadlocking adhesive.
- ▶ Torque setting: Please note the information provided under [Technical details](#)  75]. Don't fully tighten the safety screws until the safety switches and actuators are correctly aligned and the function has been tested.
- ▶ If possible, conceal the installation of the safety switch and actuator.

9.2 Align safety switch and actuator



NOTICE

To ensure proper function, it is important to maintain the distance (6.3 mm) between the safety switch and actuator (for tolerances, see Technical details). It is also important that the safety switch and actuator are aligned. A steel square is helpful in this regard.

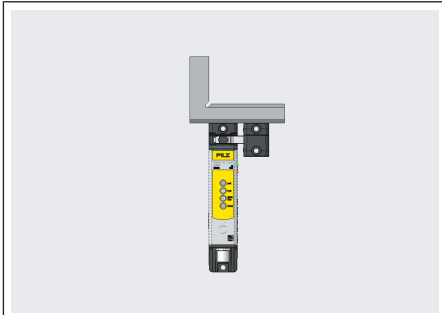

A steel square is helpful for aligning the safety switch and actuator.

Top adjustment is flush

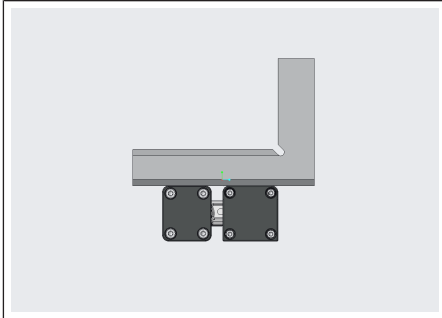

Rear adjustment is flush

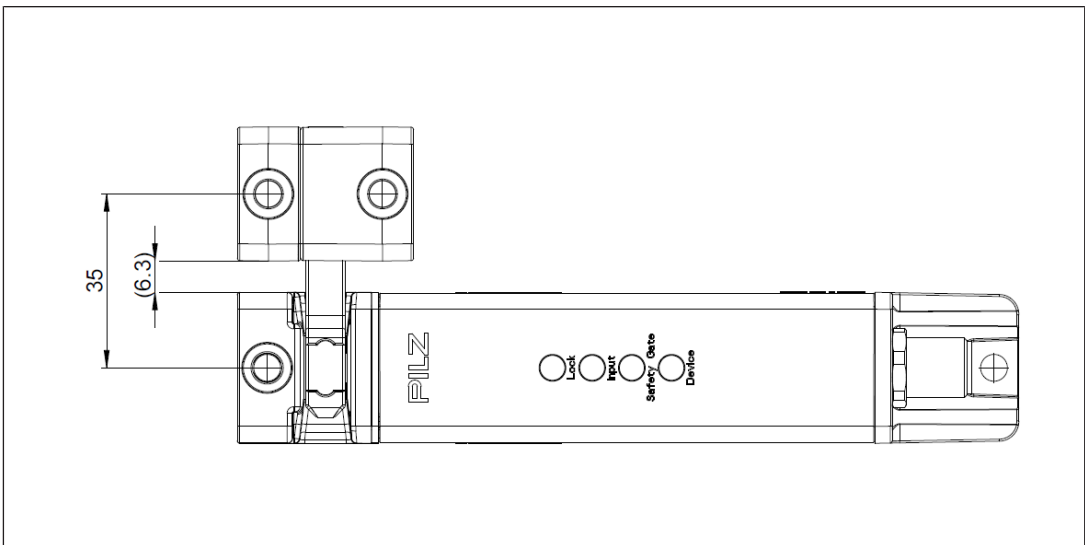

Fig.: Align safety switch and actuator a

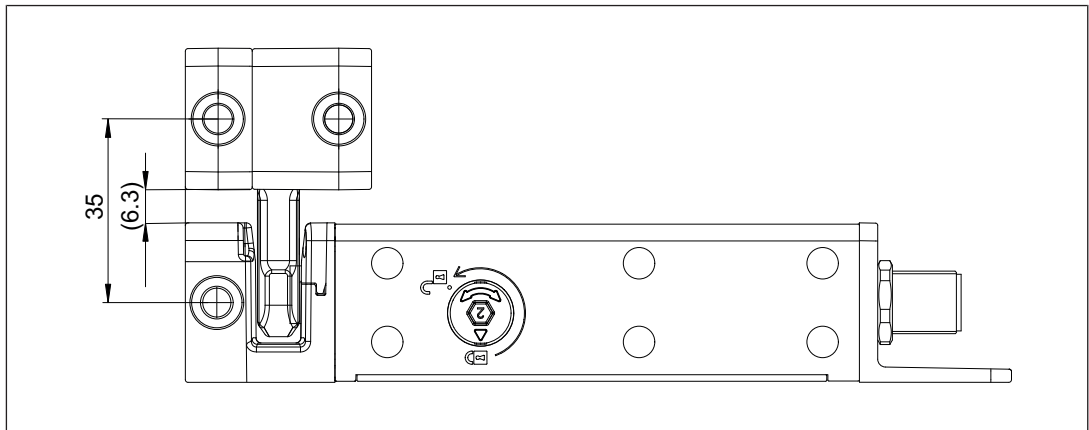



Fig.: Align safety switch and actuator b

Comply with the stated dimensions, tolerances, see [Technical details](#)  75].

9.3 Installation of multiple safety switches

When multiple safety switches are installed, you must observe the following minimum distances between them.

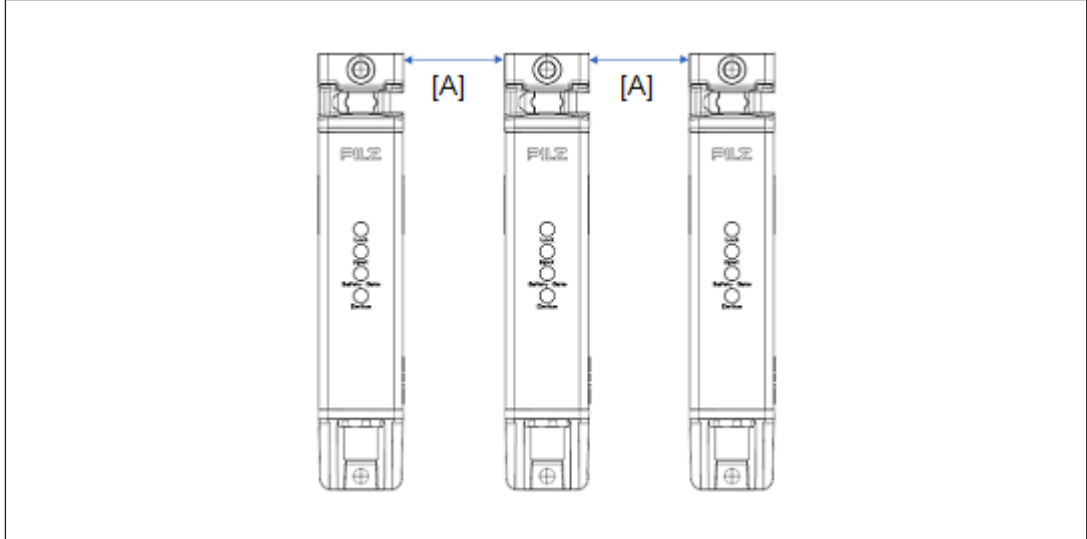

Fig.: Distances, safety switches in parallel

Legend

[A] Distances, safety switches with actuator a: > 40 mm

Distances, safety switches with actuator b: > 50 mm

The distance can be reduced if shielding (e.g. metal) is fitted between the safety switches. This will prevent interference.

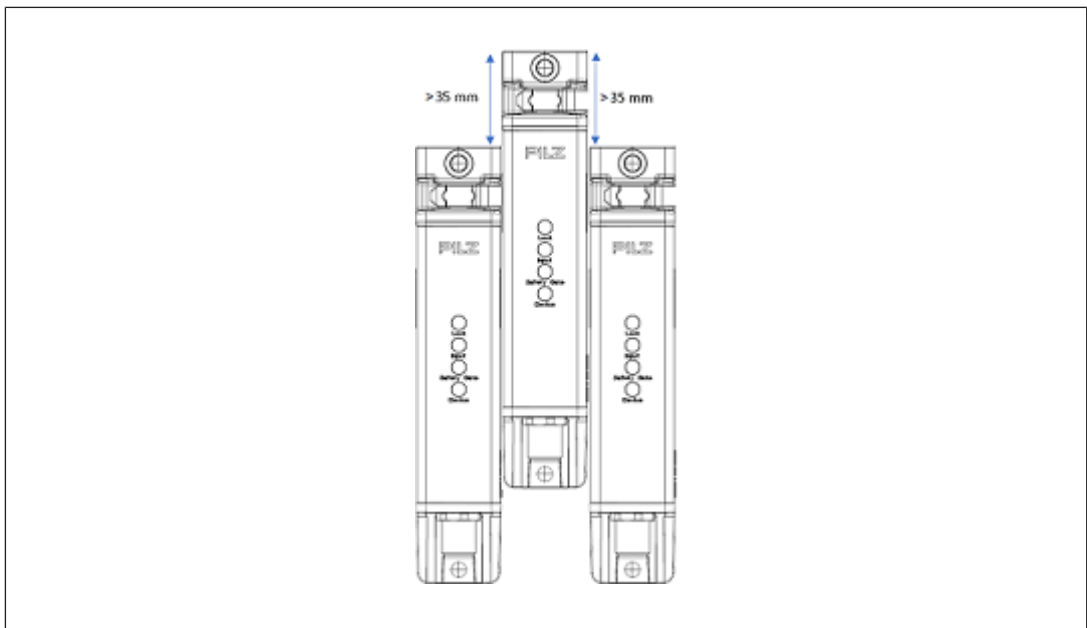

Fig.: Distances, safety switches directly in parallel, with vertical offset > 35 mm

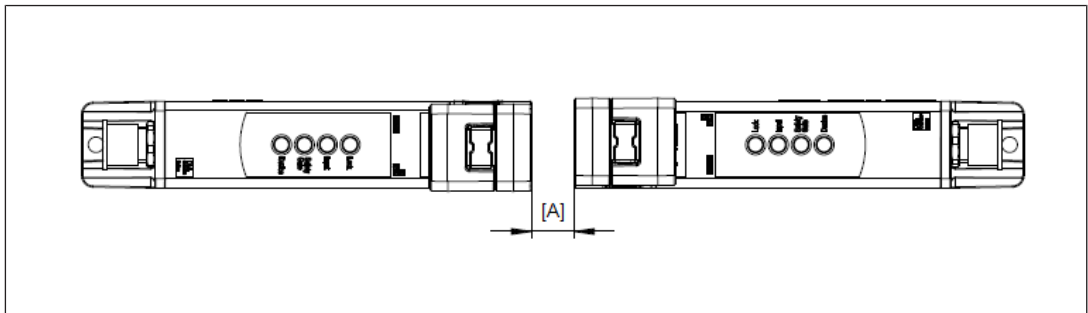

Fig.: Distances, safety switches "head to head"

Legend

- [A] Distances, safety switches with actuator a: 0 mm
- Distances, safety switches with actuator b: > 15 mm

9.4 PSEN mlm mounting types

The PSENmlock mini can be mounted as an internal or external attachment.

9.4.1 External attachment with actuator a

The following mounting examples are based on a 30 x 30 mm profile. With other profiles, mounting plates are required for safety switches and actuators.

9.4.1.1 Installation on sliding gate

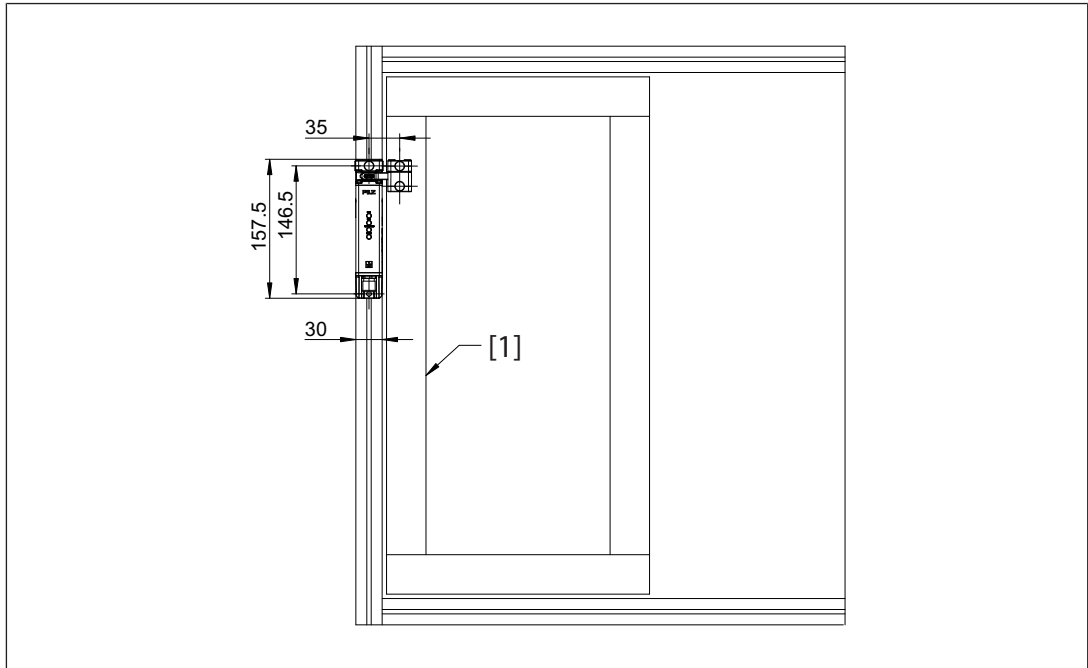

Legend

[1] Sliding gate

- ▶ Use two screws to mount the safety switch on the frame.
 - ⇒ Screw for the actuator: M5 cylinder head screw, 30 mm
 - ⇒ Screw for the male connector: M5 cylinder head screw, 8/10 mm
- ▶ Use two 30 mm M5 cylinder head screws to attach the actuator to the gate.

9.4.1.2 Installation on swing gate

Note the minimum gate radius R, see [Technical details](#) [ 75].

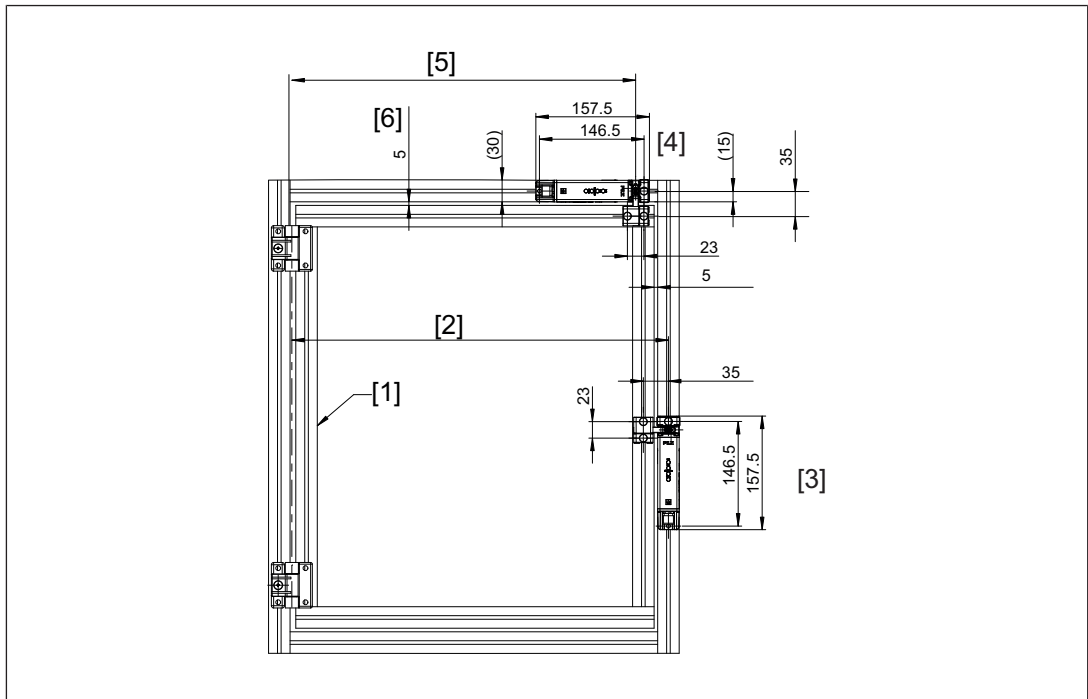

Legend

- [1] Swing gate
- [2] Gate radius R when safety switch is attached parallel to the rotational axis [3]
- [3] Safety switch attached **parallel to the rotational axis**
parallel to the rotational axis = preferred mounting type
- [4] Safety switch attached across the rotational axis
- [5] Gate radius R when safety switch is attached across the rotational axis [4]
- [6] Gap between gate and frame

- ▶ Use two screws to mount the safety switch on the frame.
 - ⇒ Screw for the actuator: M5 cylinder head screw, 30 mm
 - ⇒ Screw for the male connector: M5 cylinder head screw, 8/10 mm
- ▶ Use two 30 mm M5 cylinder head screws to attach the actuator to the gate.

The actuator should engage smoothly into the safety switch.

Maintain a slight parallel offset from the gate's rotation point when installing the actuator.

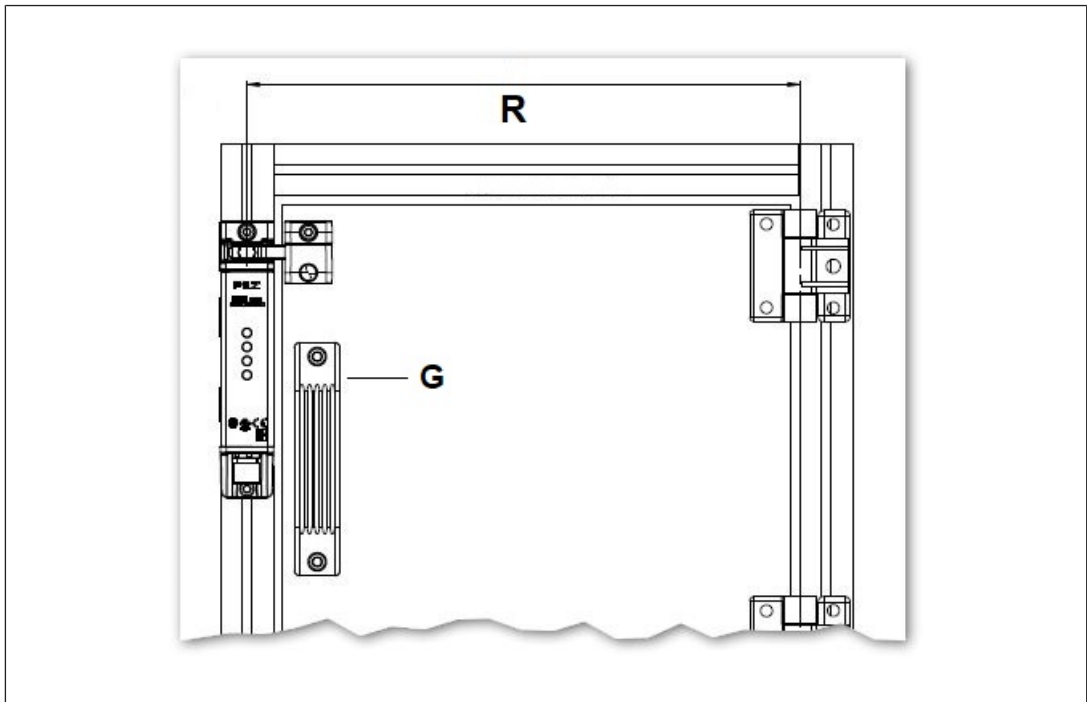
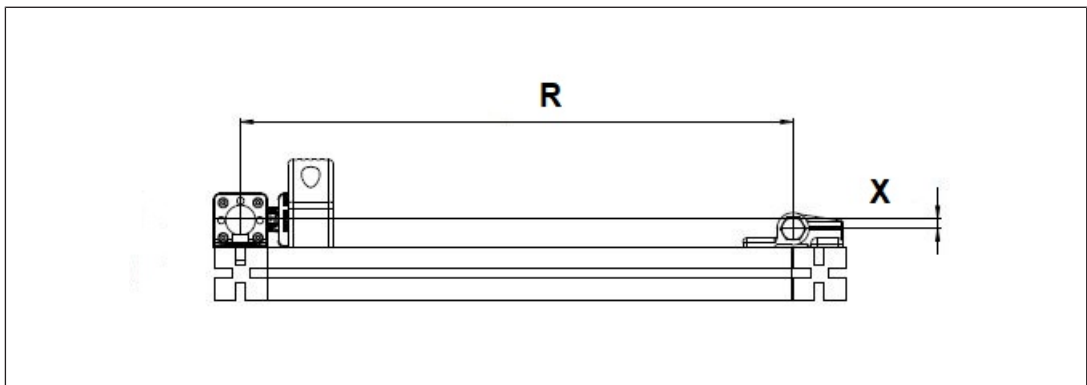

Fig.: External attachment parallel to the rotational axis



Legend

[R] Gate radius R

[X] X-dimension

[G] Handle

Factors that positively influence the smooth insertion of the actuator into the safety switch:

- ▶ Small X-dimension
- ▶ Large gate radius R
- ▶ Little play in the gate bearing
- ▶ Gate sags very little



INFORMATION

The insertion of the actuator into the safety switch is influenced by the above factors. For this reason we recommend you use 3D data to inspect the installation situation, see www.pilz.com.

Mount safety switch on a swing gate across the rotational axis

Depending on the installation boundary conditions, a larger gate radius may be required.

9.4.2 Internal attachment with actuator b

Depending on the application, mounting plates/mounting brackets may be required for internal attachment of the safety switch with actuator b (see Internal attachment: Mounting of safety switch and actuator using mounting set 1 (optional)).

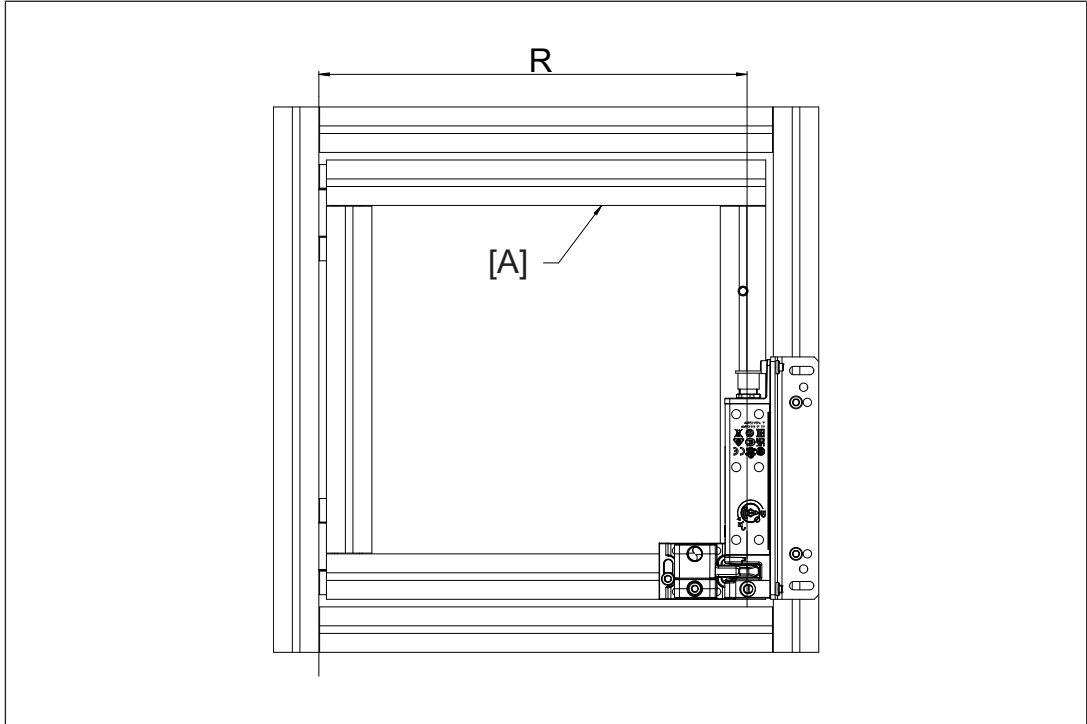
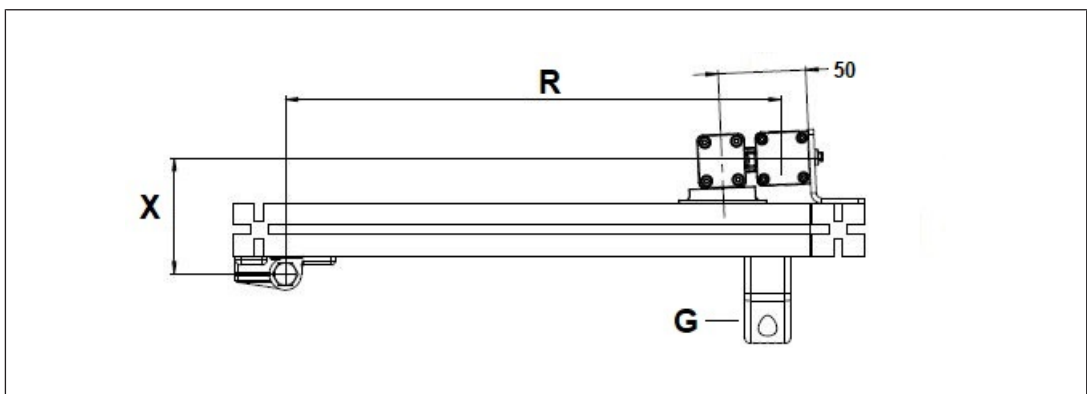

Fig.: Internal attachment parallel to the rotational axis with mounting bracket/mounting plate

Legend

[A] Gate profile 30 x 30 mm



Legend

[R] Gate radius R

[X] X-dimension

[G] Handle on the outside

Factors that positively influence the smooth insertion of the actuator into the safety switch:

- ▶ Small X-dimension

- ▶ Large gate radius R
- ▶ Little play in the gate bearing
- ▶ Gate sags very little



INFORMATION

The insertion of the actuator into the safety switch is influenced by the above factors. For this reason we recommend you use 3D data to inspect the installation situation, see www.pilz.com.



NOTICE

Auxiliary release must be reachable

On the safety switch, ensure that the auxiliary release screw is reachable with an Allen key (SW4) on one of the two sides when the gate/cover/flap is closed.

9.5 Installation safety switch

- ▶ In order to attach the safety switch at the three possible mounting positions, the foot bracket can be rotated.

As a result, the safety switch can be mounted on the frames of left and right-hinged sliding gates and swing gates. If necessary use a mounting plate or mounting bracket (see Order reference: Accessories).

Different holding forces arise, based on the installation.

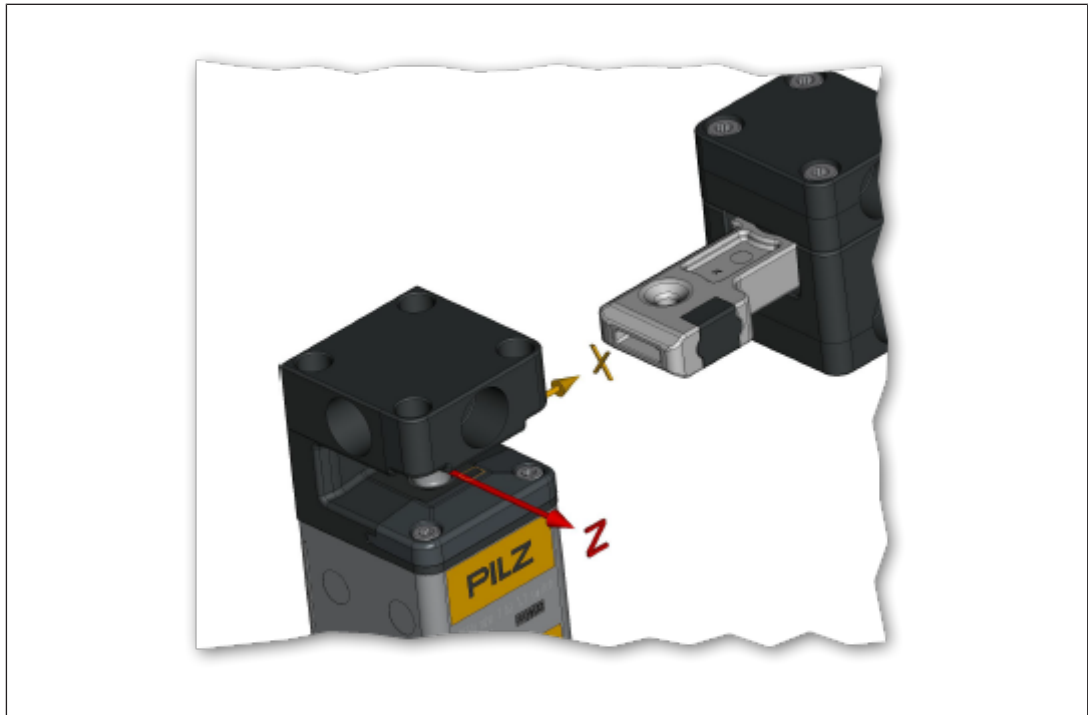
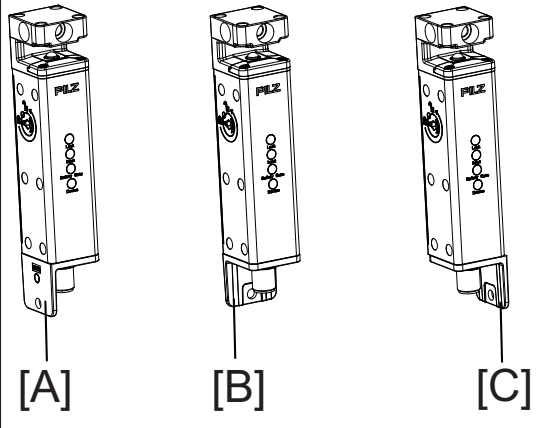
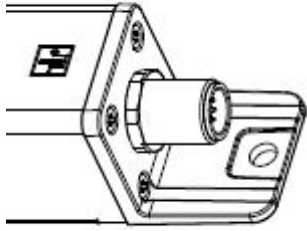

Fig.: Holding force directions

- ▶ Holding force F_{Zn} in Z-direction: 1500 N
- ▶ Holding force F_{Xn} in X-direction: 1950 N

The safety switch foot bracket can be rotated.

Adjust the foot bracket to the required mounting position.

 <p>[A] [B] [C]</p>	
<p>[A] Foot bracket mounting for left hinge [B] Foot bracket mounting for front attachment [C] Foot bracket mounting for right hinge</p>	<p>To rotate the foot bracket to the required position, loosen the four screws and then fasten them again. Fasten the four screws with a torque of 0.7 Nm.</p>

9.5.1 Mounting of safety switch using two screws

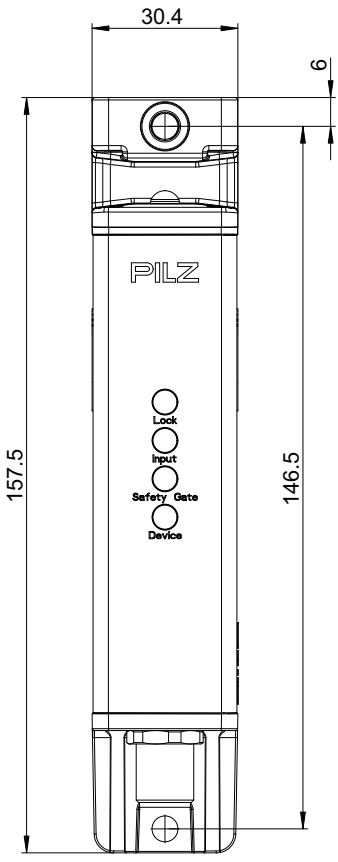
	<p>Provide the mounting surface with tapped holes as indicated.</p>
---	---

1. Attach the safety switch to the swing gate/sliding gate/flap/cover.
2. Use two M5 screws to fix the safety switch to the mounting surface.

9.6 Actuator installation

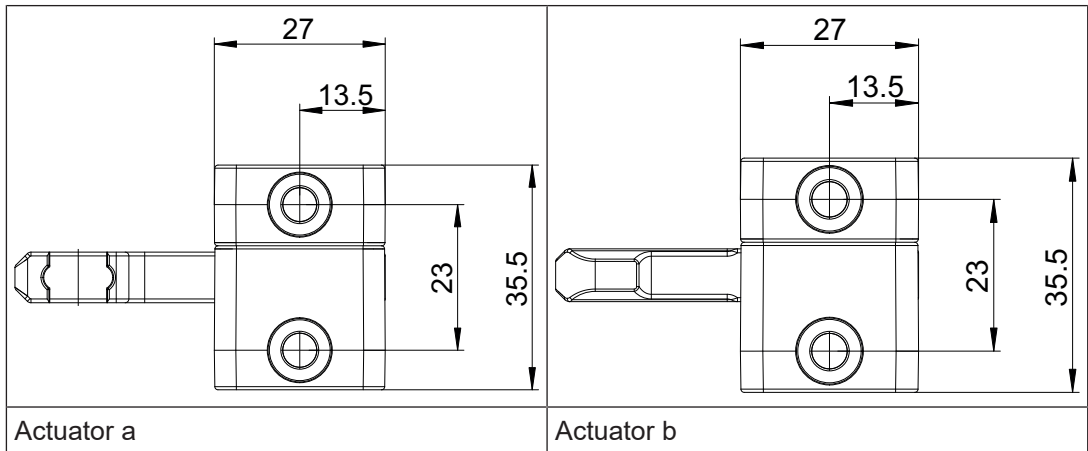

1. Attach the actuator a/b to the gate/flap/cover.
2. Use two M5 screws to fix the actuator a/b to the mounting surface.

9.7 Internal attachment: Mounting of safety switch and actuator using mounting set 1 (optional)

Depending on the application, mounting plates/mounting brackets may be required for internal attachment of the safety switch with actuator b.



NOTICE

The PSEN mIm mounting set 1 listed under accessories, material number 6K000021, is suitable for internal attachment of the safety switch parallel to the rotational axis.

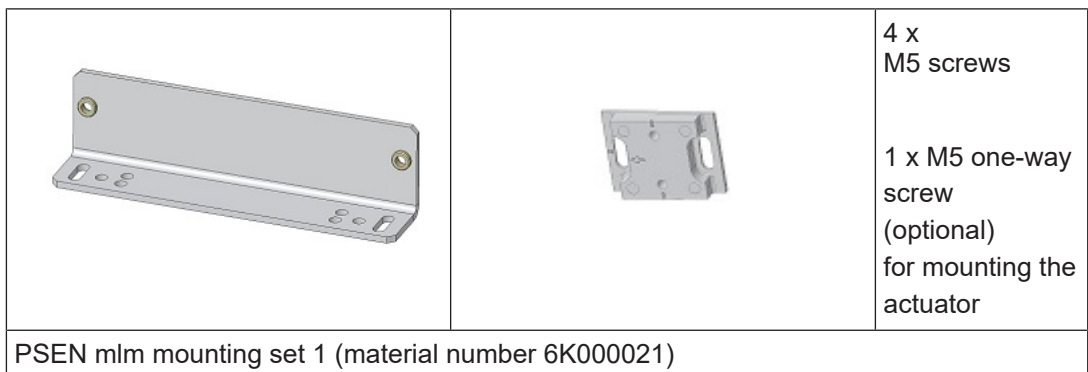

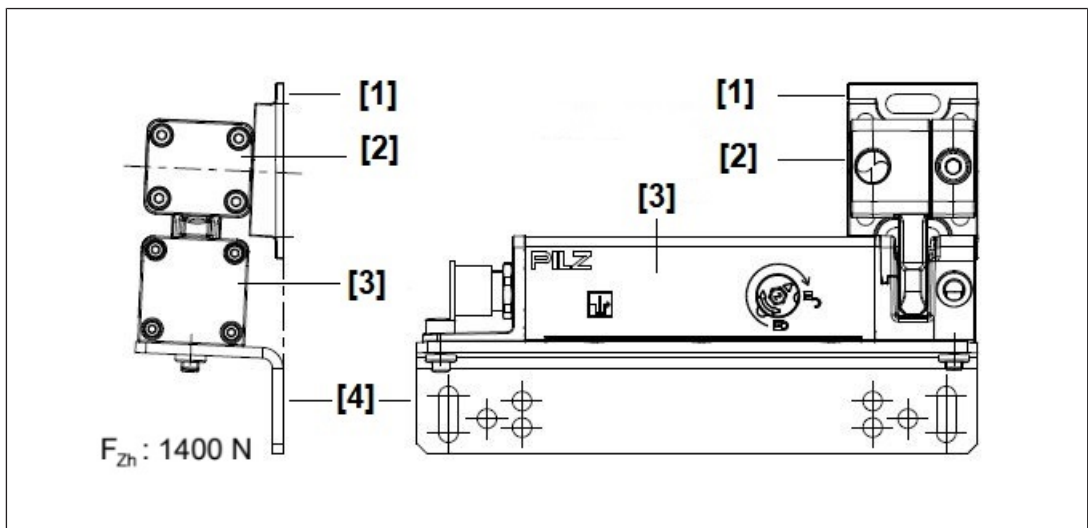

Fig.: Safety switch installed on mounting bracket and actuator on mounting plate

Legend

- [1] Mounting plate for actuator b
- [2] Actuator b (mounting using 2 screws, a one-way screw optional)
- [3] Safety switch
- [4] Bracket for safety switch (Mounting using 2 screws)
- [1] [4] PSEN mIm mounting set 1 (material number 6K000021)

Dimensions mounting bracket/mounting plate

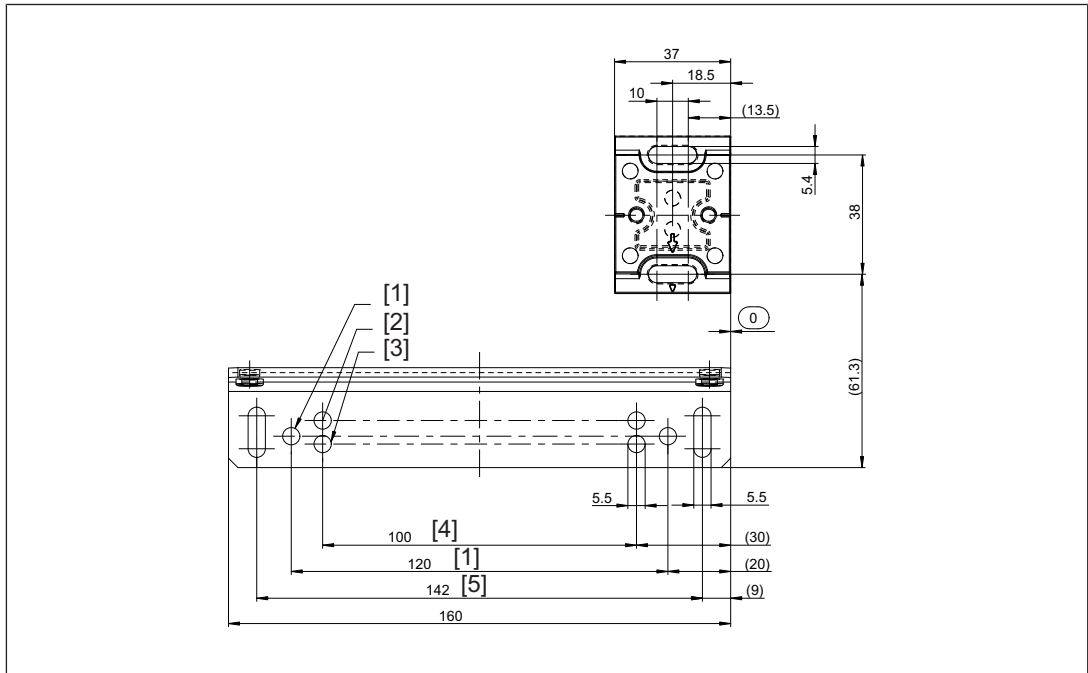



Fig.: Dimensions mounting bracket/mounting plate

Legend

- [1] Hole for screw connection to 40 mm profile
- [2] Hole for screw connection to 30 mm profile
- [3] Hole for screw connection to 45 mm profile
- [4] For 30/40 mm profile
- [5] Elongated hole for screw connection to universal profiles

9.7.1 Mounting guidelines for internally attached auxiliary release

Further information is available under [auxiliary release](#) [ 26].

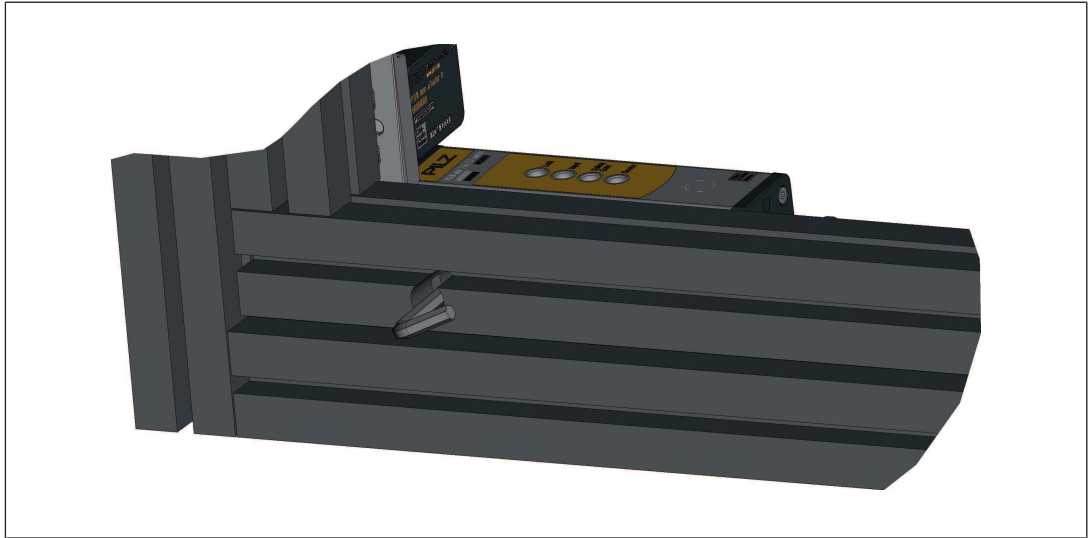

Fig.: Internally attached auxiliary release reachable with an Allen key (SW4) via a suitable opening

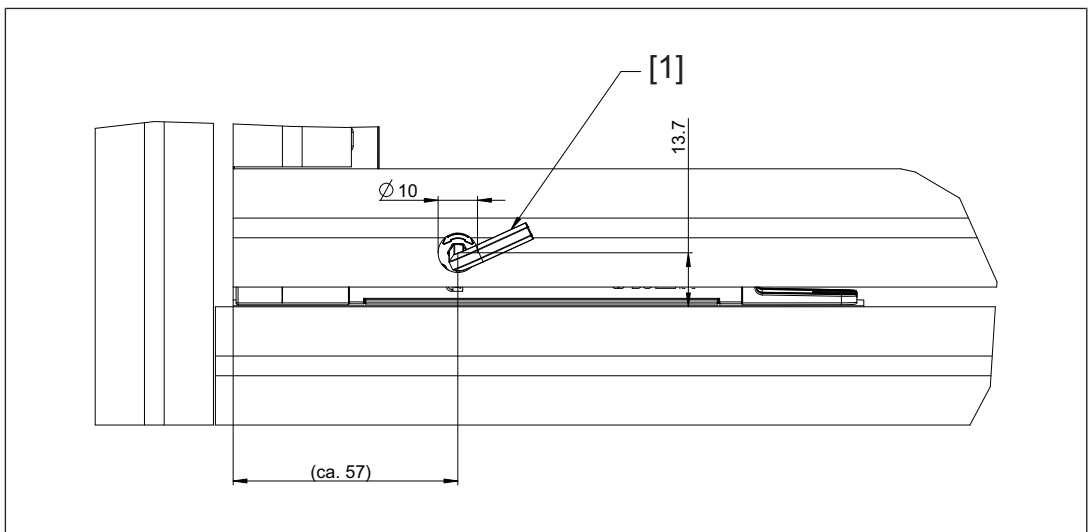







Fig.: Dimensions for reaching the auxiliary release

Legend

[1] Allen key (SW4)

10 Operation

Legend

	LED off
	LED on
	LED flashes (500 ms on, 500 ms off)
	LED flashes quickly (50 ms on, 950 ms off)
	LED flashes very quickly (25 ms on, 475 ms off)

Status indicators













- ▶ "Device" LED illuminates green: The unit is ready for operation
- ▶ "Safety Gate" LED lights up yellow: Actuator is within the response range
- ▶ "Input" LED lights up yellow: The unit is ready for operation
- ▶ "Lock" LED lights up green: Guard locking active







NOTICE



The safety functions should be checked after initial commissioning and each time the plant/machine is changed. The safety functions may only be checked by qualified personnel.

10.1 PSEN mIm in normal operation





















LED status				Switch status
Device	Safety Gate	Input	Lock	
 Green	 Yellow	 Yellow	 Green	The safety switch is started
 Green	 LED off	 Yellow	 LED off	Safety gate open, actuator not detected, guard locking deactivated
 Green	 Yellow	 Yellow	 LED off	Safety gate closed, actuator detected, guard locking deactivated

LED status				Switch status
Device	Safety Gate	Input	Lock	
 Green	 Yellow	 Yellow	 Green	Safety gate closed, actuator detected, guard locking activated





Warnings

LED status				Switch status	Remedy / measure
Device	Safety Gate	Input	Lock		
Display not definitive	Display not definitive	Display not definitive	 Green	Guard locking cannot be activated/deactivated	Check the alignment of the actuator to the safety switch. Activate/deactivate guard locking again.
 Green	Display not definitive	Display not definitive	 Red	Auxiliary release	▶ Auxiliary release: Turn back the auxiliary release screw and then recommission the safety switch (see Recommissioning [27])

















10.2 PSEN mlm in normal operation









LED status				Switch status
Device	Safety Gate	Input	Lock	
 Green	 Yellow	 Yellow	 Green	The safety switch is started
 Green	 	 	 	Safety gate open, actuator not detected, guard locking deactivated, safety inputs S11 and S21 are low
 Green	 	 Yellow	 	Safety gate open, actuator not detected, guard locking deactivated, safety inputs S11 and S21 are high
 Green	 Yellow	 Yellow	 	Safety gate closed, actuator detected, guard locking deactivated, safety inputs S11 and S21 are high
 Green	 Yellow	 Yellow	 Green	Safety gate closed, actuator detected, guard locking activated, safety inputs S11 and S21 are high

Warnings

LED status				Switch status	Remedy / measure
Device	Safety Gate	Input	Lock		
Display not definitive	Display not definitive	Display not definitive	 Green	Guard locking cannot be activated/deactivated	Check the alignment of the actuator to the safety switch. Activate/deactivate guard locking again.
 Green	Display not definitive	Display not definitive	 Red	Auxiliary release	▶ Auxiliary release: Turn back the auxiliary release screw and then recommission the safety switch (see Recommissioning [ 27])

10.3 Fault indicator PSEN mlm

LED status				Switch status	Remedy / measure
Device	Safety gate	Input	Lock		
 Red				Safety outputs in fault condition	Check the wiring and switch the supply voltage off and then on again.
 Red			 Green	Safety outputs in fault condition Guard locking can be deactivated.	Check the wiring and switch the supply voltage off and then on again.
 Red			 Green	Safety outputs in fault condition Guard locking cannot be deactivated.	Change the safety switch.
 Green			 Red	Auxiliary release	▶ Auxiliary release: Turn back the auxiliary release screw and then switch the supply voltage on (see Recommissioning [ 27]).

LED status				Switch status	Remedy / measure
Device	Safety gate	Input	Lock		
 Red				Device is in error state.	Change the safety switch.
 Green	 Yellow	Display not definitive		Wrong actuator	Only use approved combinations (see Approved combinations [ 13])

11 Checks and maintenance

It is not necessary to perform maintenance work on the product in normal operation.

- ▶ Please return any faulty product to Pilz.

Regular inspection of the switch function is required to guarantee the trouble-free, long-term function.

If the interlock and guard locking system is only used rarely (opening and closing the safety gate and activating/deactivating the guard locking device), a manual function test is required.

The correct function of the device should be checked at regular intervals and after each error.

Test intervals in accordance with EN ISO 14119:

- ▶ For PI d, at least once a year

Visual inspection

- ▶ Check the safety switch and actuator for damage.
Replace the damaged safety switch and actuator.
- ▶ Check that the safety switch and actuator are firmly secured.
Tighten the fixing screws using the appropriate torque.
- ▶ Check the offset of the safety switch and actuator.
 - Max. lateral offset
 - Max. angular offset
 - Max. vertical offset
- ▶ Check that the wiring is correct.
- ▶ Remove any dirt from the safety switch and actuator.
- ▶ (Optional) Check that the seal on the auxiliary release is intact. If the seal is not intact, use varnish to seal the auxiliary release at the area marked.

Function test

- ▶ When inserted into the safety switch, the actuator is detected and the safety gate LED lights up a constant yellow.
- ▶ The guard locking device can be activated/deactivated when the safety inputs S31 and S41 are activated.
- ▶ Under these conditions there is a high signal at safety outputs 12 and 22:
 - The actuator is detected
 - The guard locking pin has successfully been activated (guard locking pin is in the locked position)

If one of these conditions is not met, the signal at the safety outputs will be low.

Series connection of the safety channels

Before commissioning and after each change, check that the safety function is guaranteed when the gates are opened. To do this, open each gate individually and check the status at the inputs on the evaluation device:

- ▶ Close all the gates.
There must be high signals at the inputs on the evaluation device (e.g. S11, S21 or I1, I2).
- ▶ Open one gate; the other gates remain closed.
There must be low signals at the inputs on the evaluation device (e.g. S11, S21 or I1, I2).
- ▶ Close the gate again.
High signals must return at the inputs on the evaluation device (e.g. S11, S21 or I1, I2).
- ▶ Repeat the test for each gate.
- ▶ If the input signals do not react as described above, check and rectify the wiring and carry out the test again.

12 Dimensions

Safety switch PSEN mlm x ba/sa 1.1/2.1/2.2

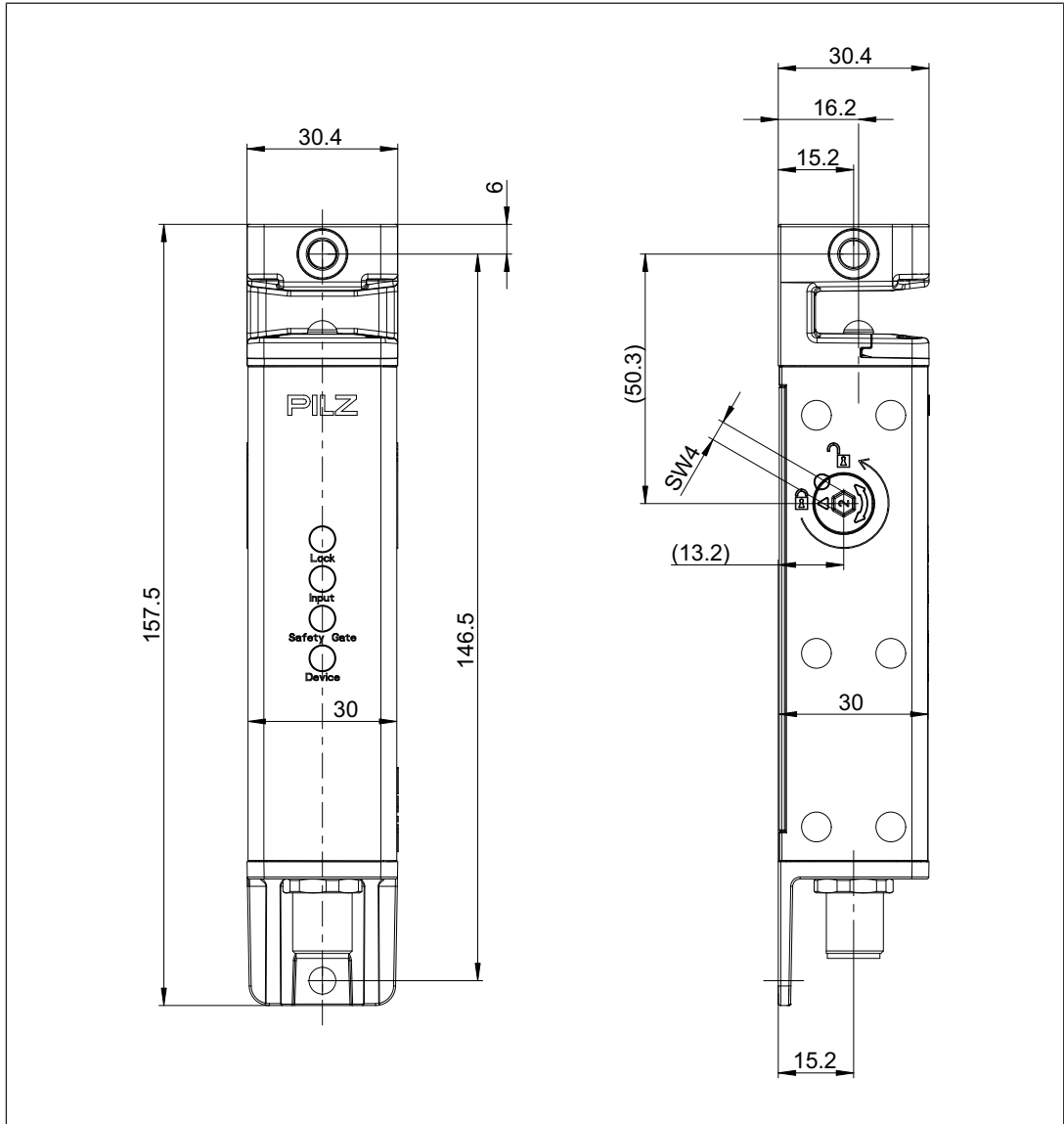

Fig.: Safety switch

Actuator a, PSEN mIm 1.1/2.1/2.2

Flexible actuator a PSEN mIm actuator af

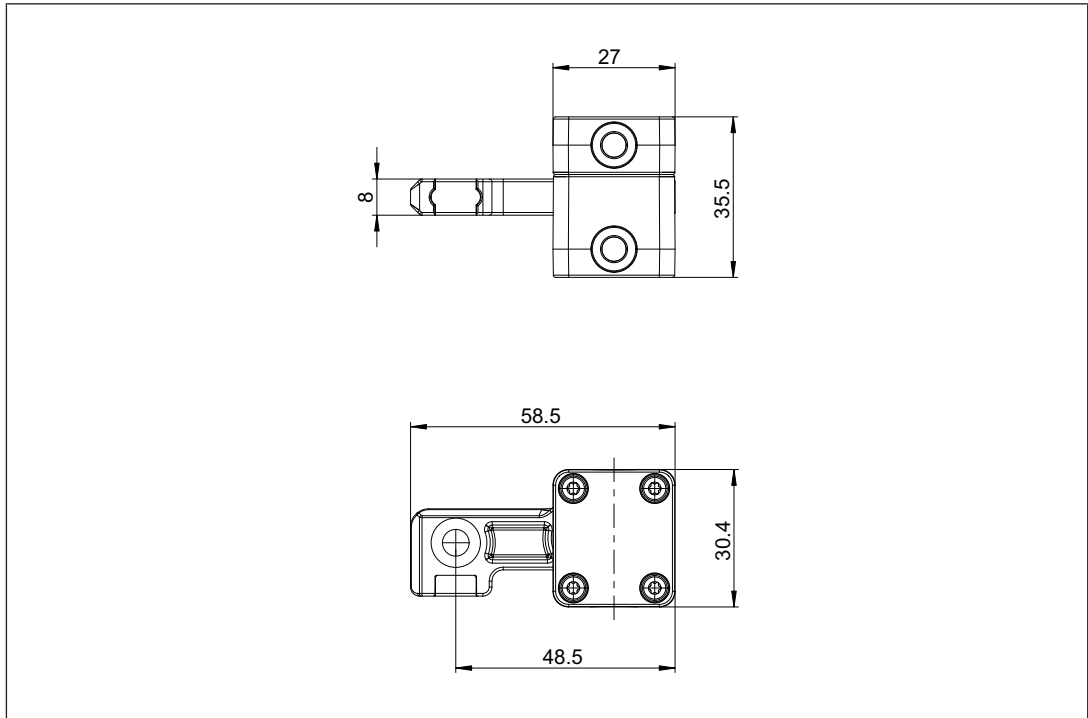

Fig.: Actuator a

Actuator b, PSEN mlm 1.1/2.1/2.2

Flexible actuator b, PSEN mlm actuator bf

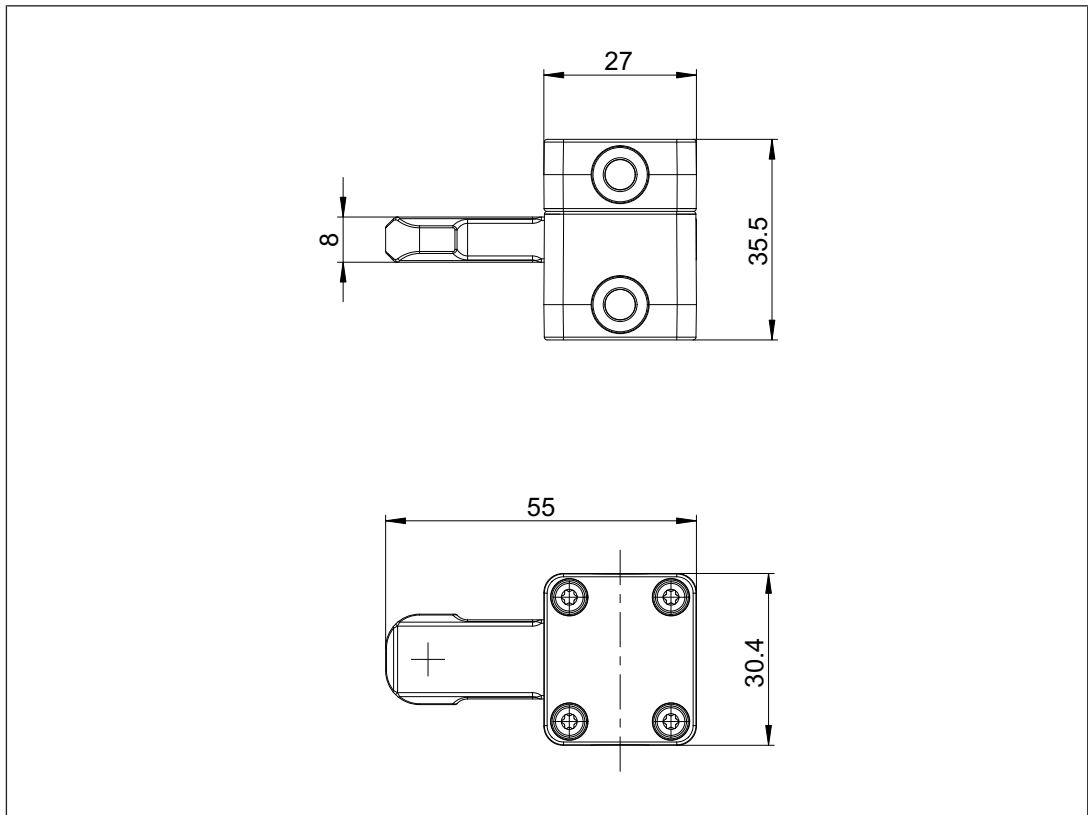

Fig.: Actuator b

13 Technical details

Where standards are undated, the 2023-08 valid editions apply.

Safety switch PSEN mlm 1 sa with actuator a

General	6K000012	6K000013	6K000014
Certifications	CE, FCC, IC, TÜV, UKCA, UL Listed	CE, FCC, IC, TÜV, UKCA, UL Listed	CE, FCC, IC, TÜV, UKCA, UL Listed
Sensor's mode of operation	Transponders	Transponders	Transponders
Coding level in accordance with EN ISO 14119	Low	High	High
Design in accordance with EN ISO 14119	4	4	4
Classification in accordance with EN 60947-5-3	PDDB	PDDB	PDDB
Pilz coding type	coded	fully coded	uniquely coded
Transponders	6K000012	6K000013	6K000014
Frequency band	127 kHz +/- 3 kHz	127 kHz +/- 3 kHz	127 kHz +/- 3 kHz
Max. transmitter output	15 mW	15 mW	15 mW
Electrical data	6K000012	6K000013	6K000014
Supply voltage			
Voltage	24 V	24 V	24 V
Kind	DC	DC	DC
Type of power supply	SELV/PELV	SELV/PELV	SELV/PELV
Voltage tolerance	-22,5 %/+20 %	-22,5 %/+20 %	-22,5 %/+20 %
Output of external power supply (DC)	0,5 W	0,5 W	0,5 W
Max. switching frequency	0,5 Hz	0,5 Hz	0,5 Hz
Max. solenoid current for t < 150 ms	1,15 A	1,15 A	1,15 A
Max. cable capacitance at the safety outputs			
No-load, PNOZ with relay contacts	40 nF	40 nF	40 nF
PNOZmulti, PNOZelog, PSS	70 nF	70 nF	70 nF
Max. inrush current impulse			
Current pulse, A1	8,4 A	8,4 A	8,4 A
Pulse duration, A1	0,0105 ms	0,0105 ms	0,0105 ms
Max. unit fuse protection in accordance with UL	1,5 A	1,5 A	1,5 A
No-load current	20 mA	20 mA	20 mA
Inputs	6K000012	6K000013	6K000014
Quantity	4	4	4

Inputs	6K000012	6K000013	6K000014
Voltage at inputs	24 V DC	24 V DC	24 V DC
Current at solenoid input	4 mA	4 mA	4 mA
Input current range	2 - 2,6 mA	2 - 2,6 mA	2 - 2,6 mA
Potential isolation between input and internal module bus voltage	No	No	No
Semiconductor outputs	6K000012	6K000013	6K000014
OSSD safety outputs	2	2	2
Signal outputs	1	1	1
Switching current per output	100 mA	100 mA	100 mA
Breaking capacity per output	2,4 W	2,4 W	2,4 W
Potential isolation from system voltage	No	No	No
Short circuit-proof	Yes	Yes	Yes
Residual current at outputs	100 µA	100 µA	100 µA
Voltage drop at OSSDs	1,25 V	1,25 V	1,25 V
Conditional rated short circuit current	100 A	100 A	100 A
Lowest operating current	1 mA	1 mA	1 mA
Utilisation category in accordance with EN 60947-1	DC-12	DC-12	DC-12
Times	6K000012	6K000013	6K000014
Max. test pulse duration, safety outputs	450 µs	450 µs	450 µs
Switch-on delay			
after UB is applied	1,2 s	1,2 s	1,2 s
Inputs typ.	40 ms	40 ms	40 ms
Inputs max.	45 ms	45 ms	45 ms
Actuator typ.	770 ms	770 ms	770 ms
Actuator max.	800 ms	800 ms	800 ms
Delay-on de-energisation			
Inputs typ.	5 ms	5 ms	5 ms
Inputs max.	5 ms	5 ms	5 ms
Risk time in accordance with EN 60947-5-3	100 ms	100 ms	100 ms
Processing time activate/deactivate guard locking	1.000 ms	1.000 ms	1.000 ms
Environmental data	6K000012	6K000013	6K000014
Ambient temperature			
in accordance with the standard	EN 60068-2-14	EN 60068-2-14	EN 60068-2-14
Temperature range	-10 - 60 °C	-10 - 60 °C	-10 - 60 °C

Environmental data	6K000012	6K000013	6K000014
Storage temperature			
in accordance with the standard	EN 60068-2-1/-2	EN 60068-2-1/-2	EN 60068-2-1/-2
Temperature range	-25 - 70 °C	-25 - 70 °C	-25 - 70 °C
Climatic suitability			
in accordance with the standard	EN 60068-2-78	EN 60068-2-78	EN 60068-2-78
Humidity	93 % r. h. at 40 °C	93 % r. h. at 40 °C	93 % r. h. at 40 °C
Max. operating height above SL	2000 m	2000 m	2000 m
EMC	EN 301489-1 V2.1.1, EN 55011: class A, EN 60947-5-2, EN 60947-5-3	EN 301489-1 V2.1.1, EN 55011: class A, EN 60947-5-2, EN 60947-5-3	EN 301489-1 V2.1.1, EN 55011: class A, EN 60947-5-2, EN 60947-5-3
Vibration			
in accordance with the standard	EN 60947-5-2	EN 60947-5-2	EN 60947-5-2
Frequency	10 - 55 Hz	10 - 55 Hz	10 - 55 Hz
Amplitude	1 mm	1 mm	1 mm
Shock stress			
in accordance with the standard	EN 60947-5-2	EN 60947-5-2	EN 60947-5-2
Number of shocks	3	3	3
Acceleration	30g	30g	30g
Duration	11 ms	11 ms	11 ms
Airgap creepage			
Overvoltage category	II	II	II
Pollution degree	2	2	2
Rated insulation voltage	75 V	75 V	75 V
Rated impulse withstand voltage	1 kV	1 kV	1 kV
Protection type			
Housing	IP65, IP67	IP65, IP67	IP65, IP67
Mechanical data	6K000012	6K000013	6K000014
Escape release included	No	No	No
Mechanical life	1,000,000 cycles	1,000,000 cycles	1,000,000 cycles
Holding force FZh			
in Z-direction	1500 N	1500 N	1500 N
in X-direction	1950 N	1950 N	1950 N
Holding force F1Max in accordance with ISO 14119			
in Z-direction	3000 N	3000 N	3000 N
in X-direction	3900 N	3900 N	3900 N
Latching force	11 N	11 N	11 N
Max. vertical offset	+/-0,25 mm	+/-0,25 mm	+/-0,25 mm
Max. lateral offset	+/- 1,0 mm	+/- 1,0 mm	+/- 1,0 mm

Mechanical data	6K000012	6K000013	6K000014
Max. angular offset around the X axis	+/-3,1 deg	+/-3,1 deg	+/-3,1 deg
Max. angular offset around the Y axis	-5/+12 deg	-5/+12 deg	-5/+12 deg
Max. angular offset around the Z axis	+/-2,3 deg	+/-2,3 deg	+/-2,3 deg
Max. offset in closing direction	+/-2 mm	+/-2 mm	+/-2 mm
Max. retract speed of actuator	0,3 m/s	0,3 m/s	0,3 m/s
Actuator 1	PSEN mlm actuator a	PSEN mlm actuator a	PSEN mlm actuator a
Min. distance between safety switches	40 mm	40 mm	40 mm
Connection type	M12, 12-pin male connector	M12, 12-pin male connector	M12, 12-pin male connector
Max. cable length when using 1 safety switch	45 m	45 m	45 m
Material	Stainless steel, plastic, galvanised steel, die cast zinc	Stainless steel, plastic, galvanised steel, die cast zinc	Stainless steel, plastic, galvanised steel, die cast zinc
Max. fixing screws torque settings	6 - 6,5 Nm	6 - 6,5 Nm	6 - 6,5 Nm
Min. gate radius	200 mm	200 mm	200 mm
Dimensions			
Height	157,5 mm	157,5 mm	157,5 mm
Width	30,4 mm	30,4 mm	30,4 mm
Depth	30,4 mm	30,4 mm	30,4 mm
Actuator dimensions			
Height	35,5 mm	35,5 mm	35,5 mm
Width	30,4 mm	30,4 mm	30,4 mm
Depth	58,5 mm	58,5 mm	58,5 mm
Weight of safety switch	425 g	425 g	425 g
Weight of actuator	175 g	175 g	175 g
Weight	600 g	600 g	600 g

Safety switch PSEN mlm 1 sa with actuator b

General	6K000018	6K000019	6K000020
Certifications	CE, FCC, IC, TÜV, UKCA, UL Listed	CE, FCC, IC, TÜV, UKCA, UL Listed	CE, FCC, IC, TÜV, UKCA, UL Listed
Sensor's mode of operation	Transponders	Transponders	Transponders
Coding level in accordance with EN ISO 14119	Low	High	High
Design in accordance with EN ISO 14119	4	4	4
Classification in accordance with EN 60947-5-3	PDDB	PDDB	PDDB
Pilz coding type	coded	fully coded	uniquely coded

Transponders	6K000018	6K000019	6K000020
Frequency band	127 kHz +/- 3 kHz	127 kHz +/- 3 kHz	127 kHz +/- 3 kHz
Max. transmitter output	15 mW	15 mW	15 mW
Electrical data	6K000018	6K000019	6K000020
Supply voltage			
Voltage	24 V	24 V	24 V
Kind	DC	DC	DC
Type of power supply	SELV/PELV	SELV/PELV	SELV/PELV
Voltage tolerance	-22,5 %/+20 %	-22,5 %/+20 %	-22,5 %/+20 %
Output of external power supply (DC)	0,5 W	0,5 W	0,5 W
Max. switching frequency	0,5 Hz	0,5 Hz	0,5 Hz
Max. solenoid current for t < 150 ms	1,15 A	1,15 A	1,15 A
Max. cable capacitance at the safety outputs			
No-load, PNOZ with relay contacts	40 nF	40 nF	40 nF
PNOZmulti, PNOZelog, PSS	70 nF	70 nF	70 nF
Max. inrush current impulse			
Current pulse, A1	8,4 A	8,4 A	8,4 A
Pulse duration, A1	0,0105 ms	0,0105 ms	0,0105 ms
Max. unit fuse protection in accordance with UL	1,5 A	1,5 A	1,5 A
No-load current	20 mA	20 mA	20 mA
Inputs	6K000018	6K000019	6K000020
Quantity	4	4	4
Voltage at inputs	24 V DC	24 V DC	24 V DC
Current at solenoid input	4 mA	4 mA	4 mA
Input current range	2 - 2,6 mA	2 - 2,6 mA	2 - 2,6 mA
Potential isolation between input and internal module bus voltage	No	No	No
Semiconductor outputs	6K000018	6K000019	6K000020
OSSD safety outputs	2	2	2
Signal outputs	1	1	1
Switching current per output	100 mA	100 mA	100 mA
Breaking capacity per output	2,4 W	2,4 W	2,4 W
Potential isolation from system voltage	No	No	No
Short circuit-proof	Yes	Yes	Yes
Residual current at outputs	100 µA	100 µA	100 µA
Voltage drop at OSSDs	1,25 V	1,25 V	1,25 V

Semiconductor outputs	6K000018	6K000019	6K000020
Conditional rated short circuit current	100 A	100 A	100 A
Lowest operating current	1 mA	1 mA	1 mA
Utilisation category in accordance with EN 60947-1	DC-12	DC-12	DC-12
Times	6K000018	6K000019	6K000020
Max. test pulse duration, safety outputs	450 µs	450 µs	450 µs
Switch-on delay			
after UB is applied	1,2 s	1,2 s	1,2 s
Inputs typ.	40 ms	40 ms	40 ms
Inputs max.	45 ms	45 ms	45 ms
Actuator typ.	770 ms	770 ms	770 ms
Actuator max.	800 ms	800 ms	800 ms
Delay-on de-energisation			
Inputs typ.	5 ms	5 ms	5 ms
Inputs max.	5 ms	5 ms	5 ms
Risk time in accordance with EN 60947-5-3	100 ms	100 ms	100 ms
Processing time activate/deactivate guard locking	1.000 ms	1.000 ms	1.000 ms
Environmental data	6K000018	6K000019	6K000020
Ambient temperature			
in accordance with the standard	EN 60068-2-14	EN 60068-2-14	EN 60068-2-14
Temperature range	-10 - 60 °C	-10 - 60 °C	-10 - 60 °C
Storage temperature			
in accordance with the standard	EN 60068-2-1/-2	EN 60068-2-1/-2	EN 60068-2-1/-2
Temperature range	-25 - 70 °C	-25 - 70 °C	-25 - 70 °C
Climatic suitability			
in accordance with the standard	EN 60068-2-78	EN 60068-2-78	EN 60068-2-78
Humidity	93 % r. h. at 40 °C	93 % r. h. at 40 °C	93 % r. h. at 40 °C
Max. operating height above SL	2000 m	2000 m	2000 m
EMC	EN 301489-1 V2.1.1, EN 55011: class A, EN 60947-5-2, EN 60947-5-3	EN 301489-1 V2.1.1, EN 55011: class A, EN 60947-5-2, EN 60947-5-3	EN 301489-1 V2.1.1, EN 55011: class A, EN 60947-5-2, EN 60947-5-3
Vibration			
in accordance with the standard	EN 60947-5-2	EN 60947-5-2	EN 60947-5-2
Frequency	10 - 55 Hz	10 - 55 Hz	10 - 55 Hz
Amplitude	1 mm	1 mm	1 mm

Environmental data	6K000018	6K000019	6K000020
Shock stress			
in accordance with the standard	EN 60947-5-2	EN 60947-5-2	EN 60947-5-2
Number of shocks	3	3	3
Acceleration	30g	30g	30g
Duration	11 ms	11 ms	11 ms
Airgap creepage			
Overvoltage category	II	II	II
Pollution degree	2	2	2
Rated insulation voltage	75 V	75 V	75 V
Rated impulse withstand voltage	1 kV	1 kV	1 kV
Protection type			
Housing	IP65, IP67	IP65, IP67	IP65, IP67
Mechanical data	6K000018	6K000019	6K000020
Escape release included	No	No	No
Mechanical life	1,000,000 cycles	1,000,000 cycles	1,000,000 cycles
Holding force FZ _h			
in Z-direction	1500 N	1500 N	1500 N
in X-direction	1950 N	1950 N	1950 N
Holding force F1 _{Max} in accordance with ISO 14119			
in Z-direction	3000 N	3000 N	3000 N
in X-direction	3900 N	3900 N	3900 N
Latching force	11 N	11 N	11 N
Max. vertical offset	+/-0,25 mm	+/-0,25 mm	+/-0,25 mm
Max. lateral offset	+/- 1,0 mm	+/- 1,0 mm	+/- 1,0 mm
Max. angular offset around the X axis	+/-3 deg	+/-3 deg	+/-3 deg
Max. angular offset around the Y axis	+/-12 deg	+/-12 deg	+/-12 deg
Max. angular offset around the Z axis	+/-3,2 deg	+/-3,2 deg	+/-3,2 deg
Max. offset in closing direction	+/-1 mm	+/-1 mm	+/-1 mm
Max. retract speed of actuator	0,3 m/s	0,3 m/s	0,3 m/s
Actuator 1	PSEN m1m actuator b	PSEN m1m actuator b	PSEN m1m actuator b
Min. distance between safety switches	50 mm	50 mm	50 mm
Connection type	M12, 12-pin male connector	M12, 12-pin male connector	M12, 12-pin male connector
Max. cable length when using 1 safety switch	45 m	45 m	45 m

Mechanical data	6K000018	6K000019	6K000020
Material	Stainless steel, plastic, galvanised steel, die cast zinc	Stainless steel, plastic, galvanised steel, die cast zinc	Stainless steel, plastic, galvanised steel, die cast zinc
Max. fixing screws torque settings	6 - 6,5 Nm	6 - 6,5 Nm	6 - 6,5 Nm
Min. gate radius	200 mm	200 mm	200 mm
Dimensions			
Height	157,5 mm	157,5 mm	157,5 mm
Width	30,4 mm	30,4 mm	30,4 mm
Depth	30,4 mm	30,4 mm	30,4 mm
Actuator dimensions			
Height	35,5 mm	35,5 mm	35,5 mm
Width	30,4 mm	30,4 mm	30,4 mm
Depth	55 mm	55 mm	55 mm
Weight of safety switch	425 g	425 g	425 g
Weight of actuator	170 g	170 g	170 g
Weight	595 g	595 g	595 g

Safety switch PSEN mlm 1 ba with actuator a

General	6K000009	6K000010	6K000011
Certifications	CE, FCC, IC, TÜV, UKCA, UL Listed	CE, FCC, IC, TÜV, UKCA, UL Listed	CE, FCC, IC, TÜV, UKCA, UL Listed
Sensor's mode of operation	Transponders	Transponders	Transponders
Coding level in accordance with EN ISO 14119	Low	High	High
Design in accordance with EN ISO 14119	4	4	4
Classification in accordance with EN 60947-5-3	PDDB	PDDB	PDDB
Pilz coding type	coded	fully coded	uniquely coded
Transponders	6K000009	6K000010	6K000011
Frequency band	127 kHz +/- 3 kHz	127 kHz +/- 3 kHz	127 kHz +/- 3 kHz
Max. transmitter output	15 mW	15 mW	15 mW
Electrical data	6K000009	6K000010	6K000011
Supply voltage			
Voltage	24 V	24 V	24 V
Kind	DC	DC	DC
Type of power supply	SELV/PELV	SELV/PELV	SELV/PELV
Voltage tolerance	-22,5 %/+20 %	-22,5 %/+20 %	-22,5 %/+20 %
Output of external power supply (DC)	0,5 W	0,5 W	0,5 W
Max. switching frequency	0,5 Hz	0,5 Hz	0,5 Hz
Max. solenoid current for t < 150 ms	1,15 A	1,15 A	1,15 A

Electrical data	6K000009	6K000010	6K000011
Max. cable capacitance at the safety outputs			
No-load, PNOZ with re- lay contacts	40 nF	40 nF	40 nF
PNOZmulti, PNOZelog, PSS	70 nF	70 nF	70 nF
Max. inrush current im- pulse			
Current pulse, A1	5 A	5 A	5 A
Pulse duration, A1	0,0105 ms	0,0105 ms	0,0105 ms
Max. unit fuse protection in accordance with UL	1,5 A	1,5 A	1,5 A
No-load current	20 mA	20 mA	20 mA
Inputs	6K000009	6K000010	6K000011
Quantity	2	2	2
Voltage at inputs	24 V DC	24 V DC	24 V DC
Current at solenoid input	4 mA	4 mA	4 mA
Potential isolation between input and internal module bus voltage	No	No	No
Semiconductor outputs	6K000009	6K000010	6K000011
OSSD safety outputs	2	2	2
Signal outputs	1	1	1
Switching current per out- put	100 mA	100 mA	100 mA
Breaking capacity per out- put	2,4 W	2,4 W	2,4 W
Potential isolation from system voltage	No	No	No
Short circuit-proof	Yes	Yes	Yes
Residual current at out- puts	100 µA	100 µA	100 µA
Voltage drop at OSSDs	1,25 V	1,25 V	1,25 V
Conditional rated short cir- cuit current	100 A	100 A	100 A
Lowest operating current	1 mA	1 mA	1 mA
Utilisation category in ac- cordance with EN 60947-1	DC-12	DC-12	DC-12
Times	6K000009	6K000010	6K000011
Max. test pulse duration, safety outputs	450 µs	450 µs	450 µs
Switch-on delay			
after UB is applied	1,2 s	1,2 s	1,2 s
Actuator typ.	770 ms	770 ms	770 ms
Actuator max.	800 ms	800 ms	800 ms

Times	6K000009	6K000010	6K000011
Risk time in accordance with EN 60947-5-3	100 ms	100 ms	100 ms
Processing time activate/deactivate guard locking	1.000 ms	1.000 ms	1.000 ms
Environmental data	6K000009	6K000010	6K000011
Ambient temperature			
in accordance with the standard	EN 60068-2-14	EN 60068-2-14	EN 60068-2-14
Temperature range	-10 - 60 °C	-10 - 60 °C	-10 - 60 °C
Storage temperature			
in accordance with the standard	EN 60068-2-1/-2	EN 60068-2-1/-2	EN 60068-2-1/-2
Temperature range	-25 - 70 °C	-25 - 70 °C	-25 - 70 °C
Climatic suitability			
in accordance with the standard	EN 60068-2-78	EN 60068-2-78	EN 60068-2-78
Humidity	93 % r. h. at 40 °C	93 % r. h. at 40 °C	93 % r. h. at 40 °C
Max. operating height above SL	2000 m	2000 m	2000 m
EMC	EN 301489-1 V2.1.1, EN 55011: class A, EN 60947-5-2, EN 60947-5-3	EN 301489-1 V2.1.1, EN 55011: class A, EN 60947-5-2, EN 60947-5-3	EN 301489-1 V2.1.1, EN 55011: class A, EN 60947-5-2, EN 60947-5-3
Vibration			
in accordance with the standard	EN 60947-5-2	EN 60947-5-2	EN 60947-5-2
Frequency	10 - 55 Hz	10 - 55 Hz	10 - 55 Hz
Amplitude	1 mm	1 mm	1 mm
Shock stress			
in accordance with the standard	EN 60947-5-2	EN 60947-5-2	EN 60947-5-2
Number of shocks	3	3	3
Acceleration	30g	30g	30g
Duration	11 ms	11 ms	11 ms
Airgap creepage			
Overvoltage category	II	II	II
Pollution degree	2	2	2
Rated insulation voltage	75 V	75 V	75 V
Rated impulse withstand voltage	1 kV	1 kV	1 kV
Protection type			
Housing	IP65, IP67	IP65, IP67	IP65, IP67
Mechanical data	6K000009	6K000010	6K000011
Escape release included	No	No	No
Mechanical life	1,000,000 cycles	1,000,000 cycles	1,000,000 cycles
Holding force FZh			
in Z-direction	1500 N	1500 N	1500 N
in X-direction	1950 N	1950 N	1950 N

Mechanical data	6K000009	6K000010	6K000011
Holding force F1Max in accordance with ISO 14119			
in Z-direction	3000 N	3000 N	3000 N
in X-direction	3900 N	3900 N	3900 N
Latching force	11 N	11 N	11 N
Max. vertical offset	+/-0,25 mm	+/-0,25 mm	+/-0,25 mm
Max. lateral offset	+/- 1,0 mm	+/- 1,0 mm	+/- 1,0 mm
Max. angular offset around the X axis	+/-3,1 deg	+/-3,1 deg	+/-3 deg
Max. angular offset around the Y axis	-5/+12 deg	-5/+12 deg	+/-12 deg
Max. angular offset around the Z axis	+/-2,3 deg	+/-2,3 deg	+/-3,2 deg
Max. offset in closing direction	+/-1 mm	+/-1 mm	+/-1 mm
Max. retract speed of actuator	0,3 m/s	0,3 m/s	0,3 m/s
Actuator 1	PSEN mlm actuator a	PSEN mlm actuator a	PSEN mlm actuator a
Min. distance between safety switches	40 mm	40 mm	40 mm
Connection type	M12, 8-pin male connector	M12, 8-pin male connector	M12, 8-pin male connector
Max. cable length when using 1 safety switch	45 m	45 m	45 m
Material	Stainless steel, plastic, galvanised steel, die cast zinc	Stainless steel, plastic, galvanised steel, die cast zinc	Stainless steel, plastic, galvanised steel, die cast zinc
Max. fixing screws torque settings	6 - 6,5 Nm	6 - 6,5 Nm	6 - 6,5 Nm
Min. gate radius	200 mm	200 mm	200 mm
Dimensions			
Height	157,5 mm	157,5 mm	157,5 mm
Width	30,4 mm	30,4 mm	30,4 mm
Depth	30,4 mm	30,4 mm	30,4 mm
Actuator dimensions			
Height	35,5 mm	35,5 mm	35,5 mm
Width	30,4 mm	30,4 mm	30,4 mm
Depth	58,5 mm	58,5 mm	58,5 mm
Weight of safety switch	425 g	425 g	425 g
Weight of actuator	175 g	175 g	175 g
Weight	600 g	600 g	600 g

Safety switch PSEN mlm 1 ba with actuator b

General	6K000015	6K000016	6K000017
Certifications	CE, FCC, IC, TÜV, UKCA, UL Listed	CE, FCC, IC, TÜV, UKCA, UL Listed	CE, FCC, IC, TÜV, UKCA, UL Listed

General	6K000015	6K000016	6K000017
Sensor's mode of operation	Transponders	Transponders	Transponders
Coding level in accordance with EN ISO 14119	Low	High	High
Design in accordance with EN ISO 14119	4	4	4
Classification in accordance with EN 60947-5-3	PDDB	PDDB	PDDB
Pilz coding type	coded	fully coded	uniquely coded
Transponders	6K000015	6K000016	6K000017
Frequency band	127 kHz +/- 3 kHz	127 kHz +/- 3 kHz	127 kHz +/- 3 kHz
Max. transmitter output	15 mW	15 mW	15 mW
Electrical data	6K000015	6K000016	6K000017
Supply voltage			
Voltage	24 V	24 V	24 V
Kind	DC	DC	DC
Type of power supply	SELV/PELV	SELV/PELV	SELV/PELV
Voltage tolerance	-22,5 %/+20 %	-22,5 %/+20 %	-22,5 %/+20 %
Output of external power supply (DC)	0,5 W	0,5 W	0,5 W
Max. switching frequency	0,5 Hz	0,5 Hz	0,5 Hz
Max. solenoid current for t < 150 ms	1,15 A	1,15 A	1,15 A
Max. cable capacitance at the safety outputs			
No-load, PNOZ with relay contacts	40 nF	40 nF	40 nF
PNOZmulti, PNOZelog, PSS	70 nF	70 nF	70 nF
Max. inrush current impulse			
Current pulse, A1	5 A	5 A	5 A
Pulse duration, A1	0,0105 ms	0,0105 ms	0,0105 ms
Max. unit fuse protection in accordance with UL	1,5 A	1,5 A	1,5 A
No-load current	20 mA	20 mA	20 mA
Inputs	6K000015	6K000016	6K000017
Quantity	2	2	2
Voltage at inputs	24 V DC	24 V DC	24 V DC
Current at solenoid input	4 mA	4 mA	4 mA
Potential isolation between input and internal module bus voltage	No	No	No
Semiconductor outputs	6K000015	6K000016	6K000017
OSSD safety outputs	2	2	2
Signal outputs	1	1	1

Semiconductor outputs	6K000015	6K000016	6K000017
Switching current per output	100 mA	100 mA	100 mA
Breaking capacity per output	2,4 W	2,4 W	2,4 W
Potential isolation from system voltage	No	No	No
Short circuit-proof	Yes	Yes	Yes
Residual current at outputs	100 µA	100 µA	100 µA
Voltage drop at OSSDs	1,25 V	1,25 V	1,25 V
Conditional rated short circuit current	100 A	100 A	100 A
Lowest operating current	1 mA	1 mA	1 mA
Utilisation category in accordance with EN 60947-1	DC-12	DC-12	DC-12
Times	6K000015	6K000016	6K000017
Max. test pulse duration, safety outputs	450 µs	450 µs	450 µs
Switch-on delay			
after UB is applied	1,2 s	1,2 s	1,2 s
Actuator typ.	770 ms	770 ms	770 ms
Actuator max.	800 ms	800 ms	800 ms
Risk time in accordance with EN 60947-5-3	100 ms	100 ms	100 ms
Processing time activate/deactivate guard locking	1.000 ms	1.000 ms	1.000 ms
Environmental data	6K000015	6K000016	6K000017
Ambient temperature			
in accordance with the standard	EN 60068-2-14	EN 60068-2-14	EN 60068-2-14
Temperature range	-10 - 60 °C	-10 - 60 °C	-10 - 60 °C
Storage temperature			
in accordance with the standard	EN 60068-2-1/-2	EN 60068-2-1/-2	EN 60068-2-1/-2
Temperature range	-25 - 70 °C	-25 - 70 °C	-25 - 70 °C
Climatic suitability			
in accordance with the standard	EN 60068-2-78	EN 60068-2-78	EN 60068-2-78
Humidity	93 % r. h. at 40 °C	93 % r. h. at 40 °C	93 % r. h. at 40 °C
Max. operating height above SL	2000 m	2000 m	2000 m
EMC	EN 301489-1 V2.1.1, EN 55011: class A, EN 60947-5-2, EN 60947-5-3	EN 301489-1 V2.1.1, EN 55011: class A, EN 60947-5-2, EN 60947-5-3	EN 301489-1 V2.1.1, EN 55011: class A, EN 60947-5-2, EN 60947-5-3

Environmental data	6K000015	6K000016	6K000017
Vibration			
in accordance with the standard	EN 60947-5-2	EN 60947-5-2	EN 60947-5-2
Frequency	10 - 55 Hz	10 - 55 Hz	10 - 55 Hz
Amplitude	1 mm	1 mm	1 mm
Shock stress			
in accordance with the standard	EN 60947-5-2	EN 60947-5-2	EN 60947-5-2
Number of shocks	3	3	3
Acceleration	30g	30g	30g
Duration	11 ms	11 ms	11 ms
Airgap creepage			
Overvoltage category	II	II	II
Pollution degree	2	2	2
Rated insulation voltage	75 V	75 V	75 V
Rated impulse withstand voltage	1 kV	1 kV	1 kV
Protection type			
Housing	IP65, IP67	IP65, IP67	IP65, IP67
Mechanical data	6K000015	6K000016	6K000017
Escape release included	No	No	No
Mechanical life	1,000,000 cycles	1,000,000 cycles	1,000,000 cycles
Holding force FZh			
in Z-direction	1500 N	1500 N	1500 N
in X-direction	1950 N	1950 N	1950 N
Holding force F1Max in accordance with ISO 14119			
in Z-direction	3000 N	3000 N	3000 N
in X-direction	3900 N	3900 N	3900 N
Latching force	11 N	11 N	11 N
Max. vertical offset	+/-0,25 mm	+/-0,25 mm	+/-0,25 mm
Max. lateral offset	+/- 1,0 mm	+/- 1,0 mm	+/- 1,0 mm
Max. angular offset around the X axis	+/-3 deg	+/-3 deg	+/-3 deg
Max. angular offset around the Y axis	+/-12 deg	+/-12 deg	+/-12 deg
Max. angular offset around the Z axis	+/-3,2 deg	+/-3,2 deg	+/-3,2 deg
Max. offset in closing direction	+/-1 mm	+/-1 mm	+/-1 mm
Max. retract speed of actuator	0,3 m/s	0,3 m/s	0,3 m/s
Actuator 1	PSEN m1m actuator b	PSEN m1m actuator b	PSEN m1m actuator b
Min. distance between safety switches	50 mm	50 mm	50 mm

Mechanical data	6K000015	6K000016	6K000017
Connection type	M12, 8-pin male connector	M12, 8-pin male connector	M12, 8-pin male connector
Max. cable length when using 1 safety switch	45 m	45 m	45 m
Material	Stainless steel, plastic, galvanised steel, die cast zinc	Stainless steel, plastic, galvanised steel, die cast zinc	Stainless steel, plastic, galvanised steel, die cast zinc
Max. fixing screws torque settings	6 - 6,5 Nm	6 - 6,5 Nm	6 - 6,5 Nm
Min. gate radius	200 mm	200 mm	200 mm
Dimensions			
Height	157,5 mm	157,5 mm	157,5 mm
Width	30,4 mm	30,4 mm	30,4 mm
Depth	30,4 mm	30,4 mm	30,4 mm
Actuator dimensions			
Height	35,5 mm	35,5 mm	35,5 mm
Width	30,4 mm	30,4 mm	30,4 mm
Depth	55 mm	55 mm	55 mm
Weight of safety switch	425 g	425 g	425 g
Weight of actuator	170 g	170 g	170 g
Weight	595 g	595 g	595 g



NOTICE

Different technical details apply when the safety switch PSEN mIm ba/ sa is used with a flexible actuator.

The different technical details for mechanical service life, holding force FZh, holding force F1Max and the specifications for the max. offset are listed in the short description of the PSENmlock mini Flexible Actuator (1007206).

14 Use in applications in accordance with IEC 61508 / IEC 61511

When the PSEN mlm 1 sa is used in applications in accordance with IEC 61508 / IEC 61511, the maximum achievable safety integrity level SIL can be determined from the table below (see Table 4 of ISO 13849-1:2023).

For applications with PSEN mlm 1 sa, a maximum of SIL 2 can be achieved.

Performance level PL	Safety integrity level SIL
a	No equivalent
b	1
c	1
d	2
e	3

Relationship between Performance Level (PL) and Safety Integrity Level (SIL)

The mechanical components' contribution to the safety function's PFH value can be determined via the B10d value and the application's average number of operations (n_{op}).

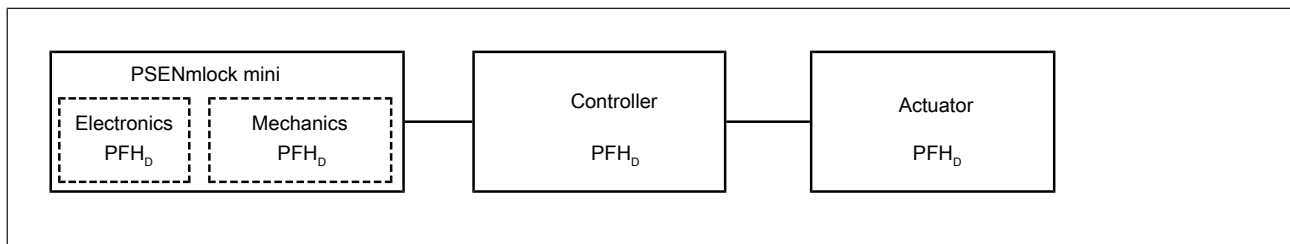

Fig.: Illustration of logic units that perform a safety function, as an example

The B10d value for PSENmlock mini is stated in Chapter 16 [Safety-related characteristic data \[94\]](#).

The user must estimate the average number of operations per year n_{op} , based on their application. Formula C.2 from EN ISO 13849-1:2023 can be used for this purpose.

$$n_{op} = \frac{d_{op} \times h_{op} \times 3600 \text{ s/h}}{t_{cycle}}$$

Legend

- n_{op} Average number of operations per year
- d_{op} Average operating time, in days per year
- h_{op} Average operating time, in hours per day
- t_{cycle} Average operating time between the start of two consecutive operating cycles, in seconds

In accordance with EN ISO 13849-1:2023, the calculation formula (C.5) for the dangerous failure rate

$\lambda_D = PFH_D$ is as follows:

$$\lambda_D = (0.1 \times n_{op}) / B10d = PFH_D$$

λ_D = Dangerous failure rate per year

PFH_D = Average frequency of a dangerous failure per year

B10d = Number of operations until 10 % have failed to danger

If the $MTTF_D$ value is required, it can be determined using the following formula:

$$MTTF_D = 1/\lambda_D$$

$MTTF_D$ = Mean time to dangerous failure, in years

Note: If λ_D or $MTTF_D$ is required in "hours", you must use 1 year = 8760 hours for the conversion.

If you have any questions regarding the use of PSENmlock mini in IEC 61508 / IEC 61511 applications, please contact technical support.

15 Classification in accordance with ZVEI, CB24I

The following tables describe the classes and specific values of the product interface and the classes of interfaces compatible with it. The classification is described in the ZVEI position paper "Classification of Binary 24 V Interfaces - Functional Safety aspects covered by dynamic testing".

Inputs

Drain		Source	
Safety switch	C2	Safety control system	C2, C3

Drain parameters	Min.	Typ.	Max.
Test impulse duration	-	-	500 µs
Input resistance	5 kOhm	-	-
Capacitive load	-	-	1 nF
Test impulse interval	2 ms	-	-

Solenoid inputs

Drain		Source	
Safety switch	C2	Safety control system	C2, C3

Drain parameters	Min.	Typ.	Max.
Test impulse duration	-	-	500 µs
Input resistance	3 kOhm	-	-
Capacitive load	-	-	1,5 nF

Safe single-pole SC outputs

Source		Drain	
Safety switch	C2	Evaluation device	C2

Parameter source	Min.	Typ.	Max.
Test pulse duration	-	-	450 µs
Max. ratio t_i/T	-	-	5 %
Rated current	-	-	0,1 A
Capacitive load	-	-	70 nF

The time statement under "Safe single-pole SC outputs" at "Test pulse duration" applies only to a safety guard locking device PSEN mIm sa and not for several safety guard locking devices PSEN mIm sa in a series connection. In a series connection the test pulse duration may be up to <1 ms.

16 Safety characteristic data



NOTICE

You must comply with the safety characteristic data in order to achieve the required safety level for your plant/machine.

Operating mode	EN ISO 13849-1: 2023	EN ISO 13849-1: 2023	EN ISO 13849-1: 2023	EN ISO 13849-1: 2023	EN ISO 13849-1: 2023
	PL	Category	PFH _D [1/h]	T _M [year]	B10d
1-ch. guard locking	PL d	Cat. 2	8,65E-10	20	1.000.000
2-ch. guard locking	PL d	Cat. 3	8,65E-10	20	1.000.000
2-ch. OSSD	PL d	Cat. 3	3,29E-09	20	1.000.000

- ▶ T_M is the maximum mission time in accordance with EN ISO 13849-1.
- ▶ The PFH value for the interlocking device already includes the optional maximum eight devices connected in series.
- ▶ For each guard locking safety function, the PFH value need only be considered once, even in a series connection.

All the units used within a safety function must be considered when calculating the safety characteristic data.



INFORMATION

A safety function's SIL/PL values are **not** identical to the SIL/PL values of the products used and may differ from these.



NOTICE

Be sure that you observe the mechanical life. The safety characteristic data are only valid as long as the values of mechanical life are met.

17 Supplementary data

17.1 Radio approval

USA/Canada

FC FCC ID: VT8-PSENMLM
IC: 7482A-PSENMLM

FCC/IC-Requirements:

This product complies with Part 15 of the FCC Rules and with Industry Canada licence-exempt RSS standards.

Operation is subject to the following two conditions:

- 1) this product may not cause harmful interference, and
- 2) this product must accept any interference received, including interference that may cause undesired operation.

Changes or modifications made to this product not expressly approved by Pilz may void the FCC authorization to operate this equipment.

NOTE: This equipment has been tested and found to comply with the limits for a Class A digital device, pursuant to Part 15 of the FCC Rules. These limits are designed to provide reasonable protection against harmful interference when the equipment is operated in a commercial environment. This equipment generates, uses, and can radiate radio frequency energy and, if not installed and used in accordance with the instruction manual, may cause harmful interference to radio communications. Operation of this equipment in a residential area is likely to cause harmful interference in which case the user will be required to correct the interference at his own expense.

This equipment complies with FCC and ISED radiation exposure limits set forth for an uncontrolled environment. This equipment should be installed and operated with minimum distance of 20 cm between the radiator and your body.

This transmitter must not be co-located or operating in conjunction with any other antenna or transmitter.

Le présent produit est conforme aux CNR d'Industrie Canada applicables aux appareils radio exempts de licence. L'exploitation est autorisée aux deux conditions suivantes:

- (1) le produit ne doit pas produire de brouillage, et
- (2) l'utilisateur de le produit doit accepter tout brouillage radioélectrique subi, même si le brouillage est susceptible d'en compromettre le fonctionnement.

Cet équipement est conforme aux limites d'exposition aux rayonnements ISED établies pour un environnement non contrôlé. Cet équipement doit être installé et utilisé avec un minimum de 20 cm de distance entre la source de rayonnement et votre corps.

Ce transmetteur ne doit pas être placé au même endroit ou utilisé simultanément avec un autre transmetteur ou antenne.

18 Order reference

18.1 System

Product type	Features	Product ID
PSEN mlm 1 sa 1.1 switch	Safety switch, coded, for safety guard locking device PSENmlock mini, application: small swing gates and sliding gates, as well as flaps and covers, safe guard locking for personal protection, bistable guard locking principle, 12-pin M12 male connector, series connection, automatic reset	6K000004
PSEN mlm 1 sa 2.1 switch	Safety switch, fully coded, for safety guard locking device PSENmlock mini, application: small swing gates and sliding gates, as well as flaps and covers, safe guard locking for personal protection, bistable guard locking principle, 12-pin M12 male connector, series connection, automatic reset	6K000005
PSEN mlm 1 sa 2.2 switch	Safety switch, uniquely coded, for safety guard locking device PSENmlock mini, application: small swing gates and sliding gates, as well as flaps and covers, safe guard locking for personal protection, bistable guard locking principle, 12-pin M12 male connector, series connection, automatic reset	6K000006
PSEN mlm actuator a	Actuator a, for safety guard locking device PSENmlock mini, side mounting, external attachment	6K000007
PSEN mlm actuator b	Actuator b, for safety guard locking device PSENmlock mini, front mounting, internal attachment	6K000008
PSEN mlm actuator af	Flexible actuator a, for safety locking device PSENmlock mini, side mounting, external attachment	6K000033
PSEN mlm actuator bf	Flexible actuator b, for safety locking device PSENmlock mini, front mounting, internal attachment	6K000034
PSEN mlm 1 sa 1.1 unit a	Safety guard locking device PSENmlock mini, coded, with safety switch and actuator a (side mounting, external attachment), application: small swing gates and sliding gates, as well as flaps and covers, safe guard locking for personal protection, bistable guard locking principle, 12-pin M12 male connector, series connection, automatic reset	6K000012
PSEN mlm 1 sa 2.1 unit a	Safety guard locking device PSENmlock mini, fully coded, with safety switch and actuator a (side mounting, external attachment), application: small swing gates and sliding gates, as well as flaps and covers, safe guard locking for personal protection, bistable guard locking principle, 12-pin M12 male connector, series connection, automatic reset	6K000013
PSEN mlm 1 sa 2.2 unit a	Safety guard locking device PSENmlock mini, uniquely coded, with safety switch and actuator a (side mounting, external attachment), application: small swing gates and sliding gates, as well as flaps and covers, safe guard locking for personal protection, bistable guard locking principle, 12-pin M12 male connector, series connection, automatic reset	6K000014

Product type	Features	Product ID
PSEN mlm 1 sa 1.1 unit b	Safety guard locking device PSENmlock mini, coded, with safety switch and actuator b (front mounting, internal attachment), application: small swing gates and sliding gates, as well as flaps and covers, safe guard locking for personal protection, bistable guard locking principle, 12-pin M12 male connector, series connection, automatic reset	6K000018
PSEN mlm 1 sa 2.1 unit b	Safety guard locking device PSENmlock mini, fully coded, with safety switch and actuator b (front mounting, internal attachment), application: small swing gates and sliding gates, as well as flaps and covers, safe guard locking for personal protection, bistable guard locking principle, 12-pin M12 male connector, series connection, automatic reset	6K000019
PSEN mlm 1 sa 2.2 unit b	Safety guard locking device PSENmlock mini, uniquely coded, with safety switch and actuator b (front mounting, internal attachment), application: small swing gates and sliding gates, as well as flaps and covers, safe guard locking for personal protection, bistable guard locking principle, 12-pin M12 male connector, series connection, automatic reset	6K000020

18.2 Accessories

Mounting accessories

Product type	Features	Product ID
PSEN mlm mounting set 1	Mounting set 1 (mounting bracket, mounting plate and screws) for internal attachment, for PSENmlock mini, appropriate for 30 mm, 40 mm or 45 mm standard profiles	6K000021
PSEN mlm cover set	Cover set for PSENmlock mini, protective caps for mounting holes on the safety switch and actuator	6K000022

Cable

Product type	Features	Connector X1	Connector X2	Connector X3	Order no.
PSEN cable axial M12 8-pole 3m	3 m	M12, 8-pin female connector, straight			540319
PSEN cable axial M12 8-pole 5m	5 m	M12, 8-pin female connector, straight			540320
PSEN cable axial M12 8-pole 10m	10 m	M12, 8-pin female connector, straight			540321
PSEN cable M12-8sf, 20m	20 m	M12, 8-pin female connector, straight			540333
PSEN cable axial M12 8-pole 30m	30 m	M12, 8-pin female connector, straight			540326

Product type	Features	Connector X1	Connector X2	Connector X3	Order no.
PSEN cable M12-8sf M12-8sm, 0.5m	0.5 m	M12, 8-pin fe- male con- nector, straight	M12, 8-pin male con- nector, straight		540345
PSEN cable M12-8sf M12-8sm, 1m	1 m	M12, 8-pin fe- male con- nector, straight	M12, 8-pin male con- nector, straight		540346
PSEN cable M12-8sf M12-8sm, 1.5m	1.5 m	M12, 8-pin fe- male con- nector, straight	M12, 8-pin male con- nector, straight		540347
PSEN cable M12-8sf M12-8sm, 2m	2 m	M12, 8-pin fe- male con- nector, straight	M12, 8-pin male con- nector, straight		540340
PSEN cable M12-8sf M12-8sm, 5m	5 m	M12, 8-pin fe- male con- nector, straight	M12, 8-pin male con- nector, straight		540341
PSEN cable M12-8sf M12-8sm, 10m	10 m	M12, 8-pin fe- male con- nector, straight	M12, 8-pin male con- nector, straight		540342
PSEN cable M12-8sf M12-8sm, 20m	20 m	M12, 8-pin fe- male con- nector, straight	M12, 8-pin male con- nector, straight		540343
PSEN cable M12-8sf M12-8sm, 30m	30 m	M12, 8-pin fe- male con- nector, straight	M12, 8-pin male con- nector, straight		540344
PSEN cable M12-12sf 2m	2 m	M12, 12-pin fe- male con- nector, straight			570350
PSEN cable M12-12sf 3m	3 m	M12, 12-pin fe- male con- nector, straight			570351
PSEN cable M12-12sf 5m	5 m	M12, 12-pin fe- male con- nector, straight			570352
PSEN cable M12-12sf 10m	10 m	M12, 12-pin fe- male con- nector, straight			570353
PSEN cable M12-12sf 20m	20 m	M12, 12-pin fe- male con- nector, straight			570354
PSEN cable M12-12sf 30m	30 m	M12, 12-pin fe- male con- nector, straight			570355
PSEN cable M12-12sf 50m	50 m	M12, 12-pin fe- male con- nector, straight			570356
PSEN cable M12-12sf/ M12-12sm 1m	1 m	M12, 12-pin fe- male con- nector, straight	M12, 12-pin male con- nector, straight		570357

Product type	Features	Connector X1	Connector X2	Connector X3	Order no.
PSEN cable M12-12sf/ M12-12sm 2m	2 m	M12, 12-pin female connector, straight	M12, 12-pin male connector, straight		570358
PSEN cable M12-12sf/ M12-12sm 3m	3 m	M12, 12-pin female connector, straight	M12, 12-pin male connector, straight		570359
PSEN cable M12-12sf/ M12-12sm 5m	5 m	M12, 12-pin female connector, straight	M12, 12-pin male connector, straight		570360
PSEN cable M12-12sf/ M12-12sm 10m	10 m	M12, 12-pin female connector, straight	M12, 12-pin male connector, straight		570361
PSEN cable M12-12sf/ M12-12sm 20m	20 m	M12, 12-pin female connector, straight	M12, 12-pin male connector, straight		570362

Series connection

Product type	Features	Connector X1	Connector X2	Connector X3	Order no.
PSEN ml Y junction M12		M12, 8-pin female connector	M12, 8-pin female connector	M12, 12-pin female connector	570486
PSEN ml end adapter		M12, 12-pin female connector	M12, 8-pin male connector		570487

Product type	Features	Product ID
Adapter/SL/ M12-8SMX/ M12-8SFX/ M12-12SF/PT	Adapter for series connection PSEN sl2-G, 12-pin M12 female connector, straight, A-coded on 8-pin M12 male connector, straight, A-coded and 8-pin M12 female connector, straight, A coded, cable length: 0.15 m.	6N000030

Terminal Block Filter

Product type	Features	Product ID
Terminal Block Filter 3-10kOhm	Terminal block with filter function 3 – 10 kOhm.	772290
Terminal Block Filter 10-30kOhm	Terminal block with filter function 10 – 30 kOhm.	772291

19 EU/EC declaration of conformity

These products meet the requirements of the directive 2006/42/EC on machinery up to and including 19 January 2027, and the EU regulation 2023/1230 of the European Parliament and of the Council from 20 January 2027. The full EU and EC declaration of conformity is available to download at www.pilz.com/manuals.

Authorised representative: Pilz GmbH & Co. KG, Felix-Wankel-Str. 2, 73760 Ostfildern, Germany

20 **EC declaration of conformity**

This product/these products meet(s) the requirements of the following directives of the European Parliament and of the Council.

- ▶ 2014/53/EU on radio equipment

The complete EC Declaration of Conformity is available on the Internet at www.pilz.com/downloads.

Representative: Pilz GmbH & Co. KG, Felix-Wankel-Str. 2, 73760 Ostfildern, Germany

21

UKCA-Declaration of Conformity

These products comply with following UK legislation: Supply of Machinery (Safety) Regulation 2008.

The complete UKCA Declaration of Conformity is available on the Internet at www.pilz.com/manuals.

Representative: Pilz Automation Technology, Pilz House, Little Colliers Field, Corby, Northamptonshire, NN18 8TJ United Kingdom, eMail: mail@pilz.co.uk

Support

Technical support is available from Pilz round the clock.

Americas

Brazil

+55 11 97569-2804

Canada

+1 888 315 7459

Mexico

+52 55 5572 1300

USA (toll-free)

+1 877-PILZUSA (745-9872)

Asia

China

+86 400-088-3566

Japan

+81 45 471-2281

South Korea

+82 31 778 3390

Australia and Oceania

Australia

+61 3 95600621

New Zealand

+64 9 6345350

Europe

Austria

+43 1 7986263-444

Belgium, Luxembourg

+32 9 3217570

France

+33 3 88104003

Germany

+49 711 3409-444

Ireland

+353 21 4804983

Italy, Malta

+39 0362 1826711

Scandinavia

+45 74436332

Spain

+34 938497433

Switzerland

+41 62 88979-32

The Netherlands

+31 347 320477

Türkiye

+90 216 5775552

United Kingdom

+44 1536 460866

You can reach our international hotline on:

+49 711 3409-222

support@pilz.com

Reporting security vulnerabilities or security incidents

If you would like to report a security vulnerability or a security incident in connection with a Pilz product, please contact our **Pilz Product Security Incident Response Team (PSIRT)**.

You can reach us at: www.pilz.com/psirt

Pilz develops environmentally-friendly products using ecological materials and energy-saving technologies. Offices and production facilities are ecologically designed, environmentally-aware and energy-saving. So Pilz offers sustainability, plus the security of using energy-efficient products and environmentally-friendly solutions.



www.pilz.com/facebook



www.pilz.com/linkedin



www.pilz.com/xing



www.pilz.com/youtube



1005802-EN-07, 2026-04 Printed in Germany
© Pilz GmbH & Co. KG, 2024

CECE, CHRE, CMSE®, IndustrialPi®, Leansate®, MYZEL®, PAS4000®, PAScal®, PASconfig®, Pilz®, PIT®, PMCprimo®, PMCprotego®, PMCTendo®, PMD®, PMI®, PNOZ®, Primo®, PSEN®, PSS®, PVS®, SafetyBUS p®, SafetyNET p®, THE SPIRIT OF SAFETY® are registered and protected trademarks of Pilz GmbH & Co. KG in some countries. We would point out that product features may vary from the details stated in this document, depending on the status at the time of publication and the scope of the equipment. We accept no responsibility for the validity, accuracy and entirety of the text and graphics presented in this information. Please contact our Technical Support if you have any questions.

We are represented internationally. Please refer to our homepage www.pilz.com for further details or contact our headquarters.

Headquarters: Pilz GmbH & Co. KG, Felix-Wankel-Straße 2, 73760 Ostfildern, Germany
Telephone: +49 711 3409-0, E-Mail: info@pilz.com, Internet: www.pilz.com

PILZ
THE SPIRIT OF SAFETY