



▶ PSEN cs5.11n

PILZ
THE SPIRIT OF SAFETY

Operating Manual-1004126-EN-05
- PSEN sensor technology



This document is the original document.

Where unavoidable, for reasons of readability, the masculine form has been selected when formulating this document. We do assure you that all persons are regarded without discrimination and on an equal basis.

All rights to this documentation are reserved by Pilz GmbH & Co. KG. Copies may be made for the user's internal purposes. Suggestions and comments for improving this documentation will be gratefully received.

CECE®, CHRE®, CMSE®, INDUSTRIAL PI®, Leansafe®, MYZEL®, PAS4000®, PAS-cal®, PASconfig®, Pilz®, PIT®, PMCprimo®, PMCprotego®, PMctendo®, PMD®, PMI®, PNOZ®, Primo®, PSEN®, PSS®, PVIS®, SafetyBUS p®, SafetyEYE®, SafetyNET p®, THE SPIRIT OF SAFETY® are registered and protected trademarks of Pilz GmbH & Co. KG in some countries.



SD means Secure Digital

Introduction	5
Validity of documentation	5
Using the documentation	5
Definition of symbols	5
Safety	6
Intended use	6
Safety regulations	7
Safety assessment	7
Use of qualified personnel	7
Warranty and liability	7
Disposal	7
For your safety	8
Unit features	8
Function description	9
Block diagram	9
Operating distances	9
Lateral and vertical offset	11
Wiring	13
Important information	13
Pin assignment, connector and cable	13
Connection to evaluation devices	14
Single connection	14
Connection to Pilz evaluation devices	15
Teaching in the actuator	16
Installation	16
Use in operating heights higher than 2000 m above sea level	18
Adjustment	18
Operation	19
Normal mode	19
Error display	19

Dimensions in mm	20
Technical details for safety switch	22
Technical details actuator	24
Classification according to ZVEI, CB24I	25
Safety characteristic data	26
Supplementary data	27
Radio approval	27
Order reference	27
Safety switch	27
Actuator	27
Complete systems	27
Accessories	28
EC declaration of conformity	29
UKCA-Declaration of Conformity	29

Introduction

Validity of documentation

This documentation is valid for the product PSEN cs5.11n. It is valid until new documentation is published.

This operating manual explains the function and operation, describes the installation and provides guidelines on how to connect the product.

Using the documentation

This document is intended for instruction. Only install and commission the product if you have read and understood this document. The document should be retained for future reference.

Definition of symbols

Information that is particularly important is identified as follows:



DANGER!

This warning must be heeded! It warns of a hazardous situation that poses an immediate threat of serious injury and death and indicates preventive measures that can be taken.



WARNING!

This warning must be heeded! It warns of a hazardous situation that could lead to serious injury and death and indicates preventive measures that can be taken.



CAUTION!

This refers to a hazard that can lead to a less serious or minor injury plus material damage, and also provides information on preventive measures that can be taken.



NOTICE

This describes a situation in which the product or devices could be damaged and also provides information on preventive measures that can be taken. It also highlights areas within the text that are of particular importance.

**INFORMATION**

This gives advice on applications and provides information on special features.

Safety**Intended use**

The safety functions of the safety switch are:

- ▶ Safe shutdown of safety outputs when the actuator is removed beyond the assured release distance s_{ar} or when the actuator is not detected
- ▶ Remain shut down safely after the actuator has been removed

The safety switch meets the requirements in accordance with:

- ▶ EN IEC 60947-5-3: PDDb with the actuator PSEN cs5.11 M12
- ▶ EN IEC 62061: SIL CL 3
- ▶ EN ISO 13849-1: PL e (Cat. 4)
- ▶ EN ISO 14119: Coding level Low, design 4

The safety switch may only be used with the corresponding actuator PSEN cs5.11 M12.

The safety level PL e (Cat. 4)/SIL CL 3 is achieved only when:

- ▶ the safety outputs use 2-channel processing.

Improper use

The following is deemed improper use in particular:

- ▶ Any component, technical or electrical modification to the product,
- ▶ Use of the product outside the areas described in this operating manual,
- ▶ Use of the product outside the technical details (see chapter entitled [Technical Details](#) [ 22]).

**NOTICE****EMC-compliant electrical installation**

The product is designed for use in an industrial environment. The product may cause interference if installed in other environments. If installed in other environments, measures should be taken to comply with the applicable standards and directives for the respective installation site with regard to interference.

Safety regulations

Safety assessment

Before using a product, a risk assessment in accordance with the Machinery Directive is required.

The product as an individual component fulfils the functional safety requirements in accordance with EN/IEC 61508, EN ISO 13849-1/2 and EN IEC 62061. However, this does not guarantee the functional safety of the overall plant/machine. To achieve the relevant safety level of the overall plant/machine's required safety functions, each safety function needs to be considered separately.

It is the responsibility of the user/operator to carry out a risk assessment for their application, in which they consider the impact of assumed errors in the wiring and take appropriate measures to control or avoid these errors.

Use of qualified personnel

The products may only be assembled, installed, programmed, commissioned, operated, decommissioned and maintained by persons who are competent to do so.

A competent person is a qualified and knowledgeable person who, because of their training, experience and current professional activity, has the specialist knowledge required. In order to inspect, assess and handle products, devices, systems, plant and machinery, this person must be familiar with the state of the art and the applicable national, European and international laws, directives and standards.

It is the company's responsibility only to employ personnel who

- ▶ Are familiar with the basic regulations concerning health and safety / accident prevention,
- ▶ Have read and understood the information provided in the section entitled Safety
- ▶ Have a good knowledge of the generic and specialist standards applicable to the specific application.

Warranty and liability

All claims to warranty and liability will be rendered invalid if

- ▶ The product was used contrary to the purpose for which it is intended,
- ▶ Damage can be attributed to not having followed the guidelines in the manual,
- ▶ Operating personnel are not suitably qualified,
- ▶ Any type of modification has been made (e.g. exchanging components on the PCB boards, soldering work etc.).

Disposal

- ▶ In safety-related applications, please comply with the mission time T_M stated in the safety-related characteristic data.
- ▶ When decommissioning, please comply with local regulations regarding the disposal of electronic devices (e.g. Electrical and Electronic Equipment Act).

For your safety**DANGER!****Risk of malfunction of pacemakers or implanted defibrillators**

The magnetic field of the safety switch may cause malfunctions of pacemakers or implanted defibrillators.

People with a pacemaker or implanted defibrillators must maintain a distance of at least 100 mm to the safety switch and actuator.

**WARNING!****Loss of safety function due to manipulation of the interlocking device**

Manipulation of the interlocking device may lead to serious injury and death.

- You should prevent any possibility of the interlocking device being manipulated through the use of a spare actuator.
- Keep the substitute actuator in a safe place and protect it from unauthorised access.
- If substitute actuators are used, these must be installed as described under [Installation](#)  16].
- If the original actuators are replaced with substitute actuators, the original actuators must be destroyed before disposal.

- ▶ Do not remove the connector's protective cap until you are just about to connect the product. This will prevent potential contamination.

Unit features

- ▶ Transponder technology for presence detection
- ▶ Pilz coding type: coded
- ▶ Dual-channel operation
- ▶ 2 safety outputs
- ▶ 1 signal output
- ▶ Magnetic latching with permanent magnet, (holding force 30 N)
- ▶ LED display for:
 - State of the actuator
 - State of the inputs (always lights up yellow)
 - Supply voltage/fault
- ▶ 1 actuation direction with 3 approach directions (see [Explanation of markings](#)  9)
 - Square marking

The guaranteed safe operating distances for the specified selections only apply when the actuator approaches the switch vertically. With other approach directions, the operating distances may partly be considerably larger.

Function description

The safety outputs may have a high or low signal, depending on the position of the actuator.

State of the outputs:

Actuator in the re- sponse range	Safety output 12	Safety output 22	Signal output Y32
Yes	High	High	High
No	Low	Low	Low

Block diagram

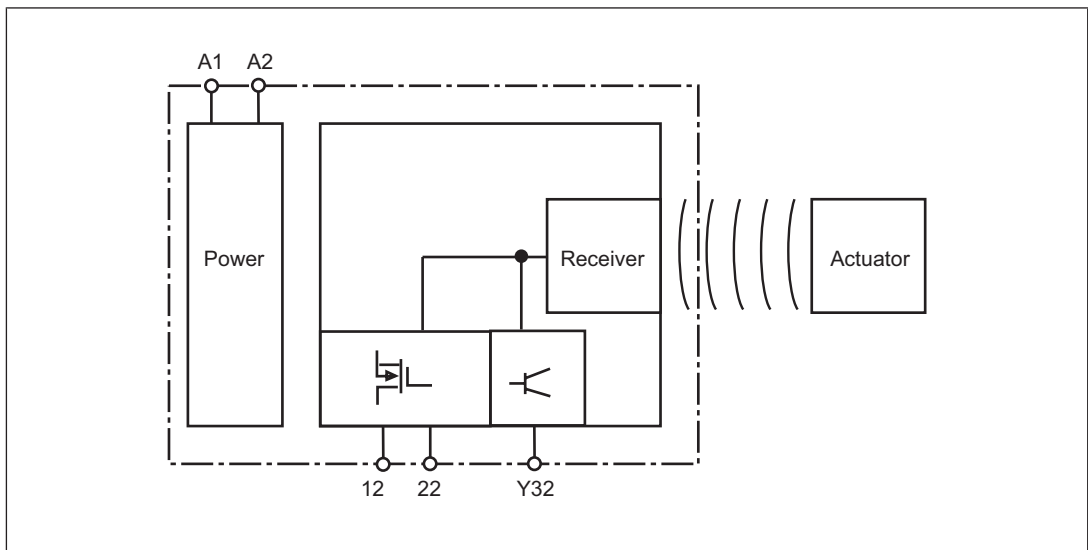

Operating distances

Alignment of the actuator	Operating distances
	<p>[1] Actuator aligned to the square marking on the switch</p> <p>S_{ao} Assured operating distance: 8 mm S_{ar} Assured release distance: 20 mm S_o Typical operating distance: 11 mm S_r Typical release distance: 14 mm</p>

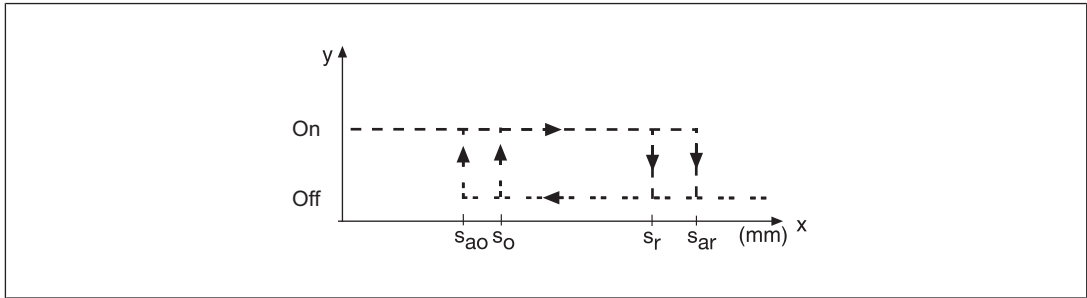

Typical course of change in the holding force as the distance from the switch to the actuator increases with frontal approach

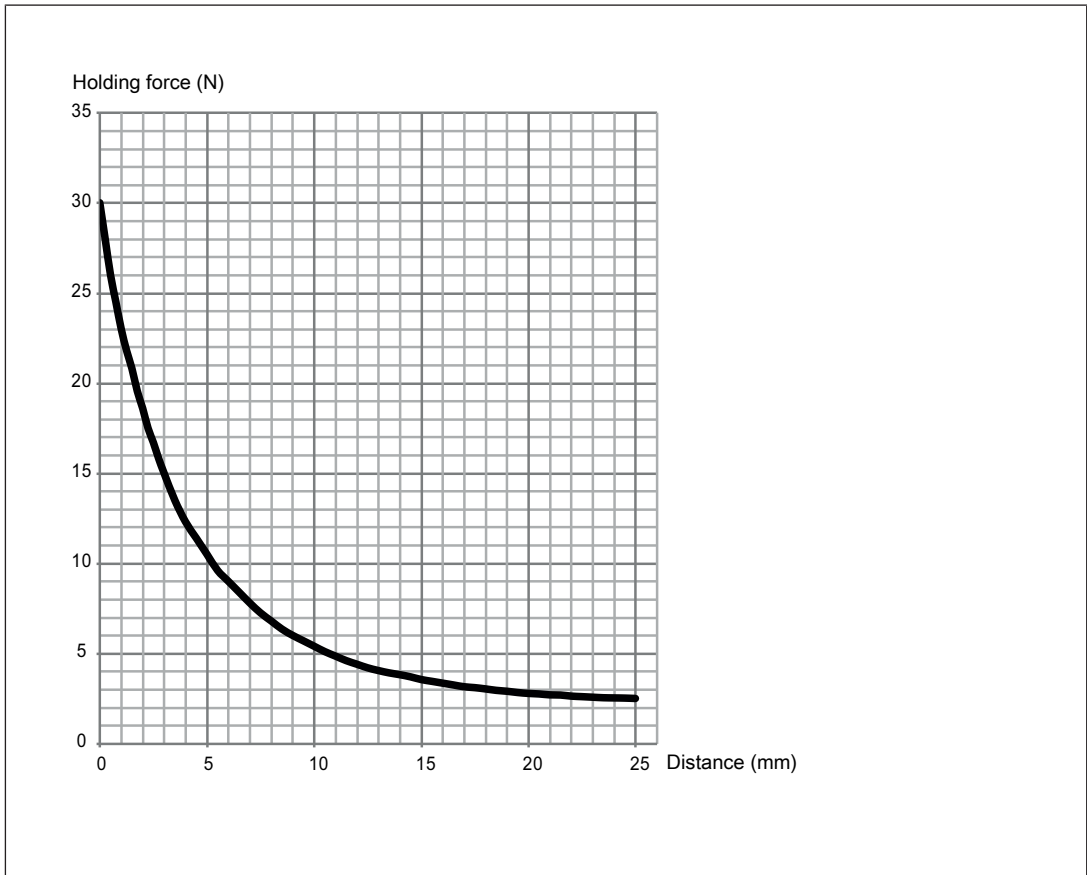
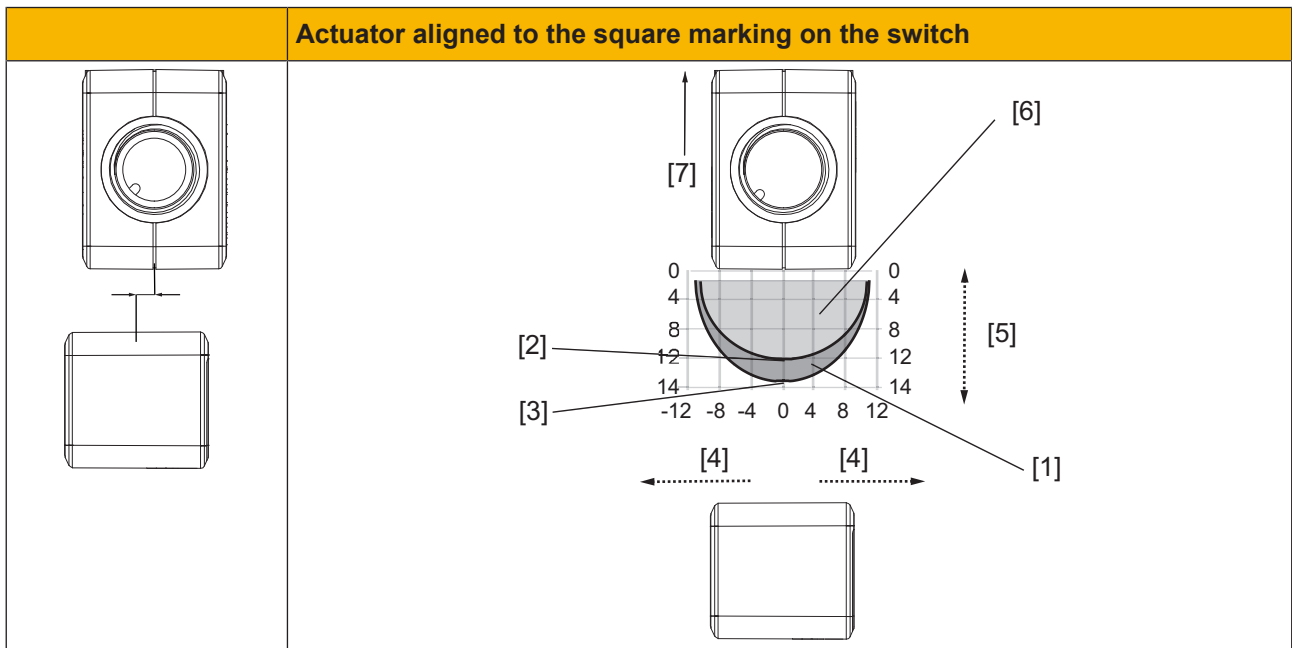

Fig.: Change in the holding force for distances from 0-25 mm

Lateral and vertical offset

Lateral offset when aligning to the triangle marking



Legend

- [1] Hysteresis
- [2] Typical operating distance S_o
- [3] Typical release distance S_r
- [4] Offset in mm
- [5] Operating distance in mm
- [6] Response range
- [7] Status of LED

Lateral offset when aligning to the triangle marking

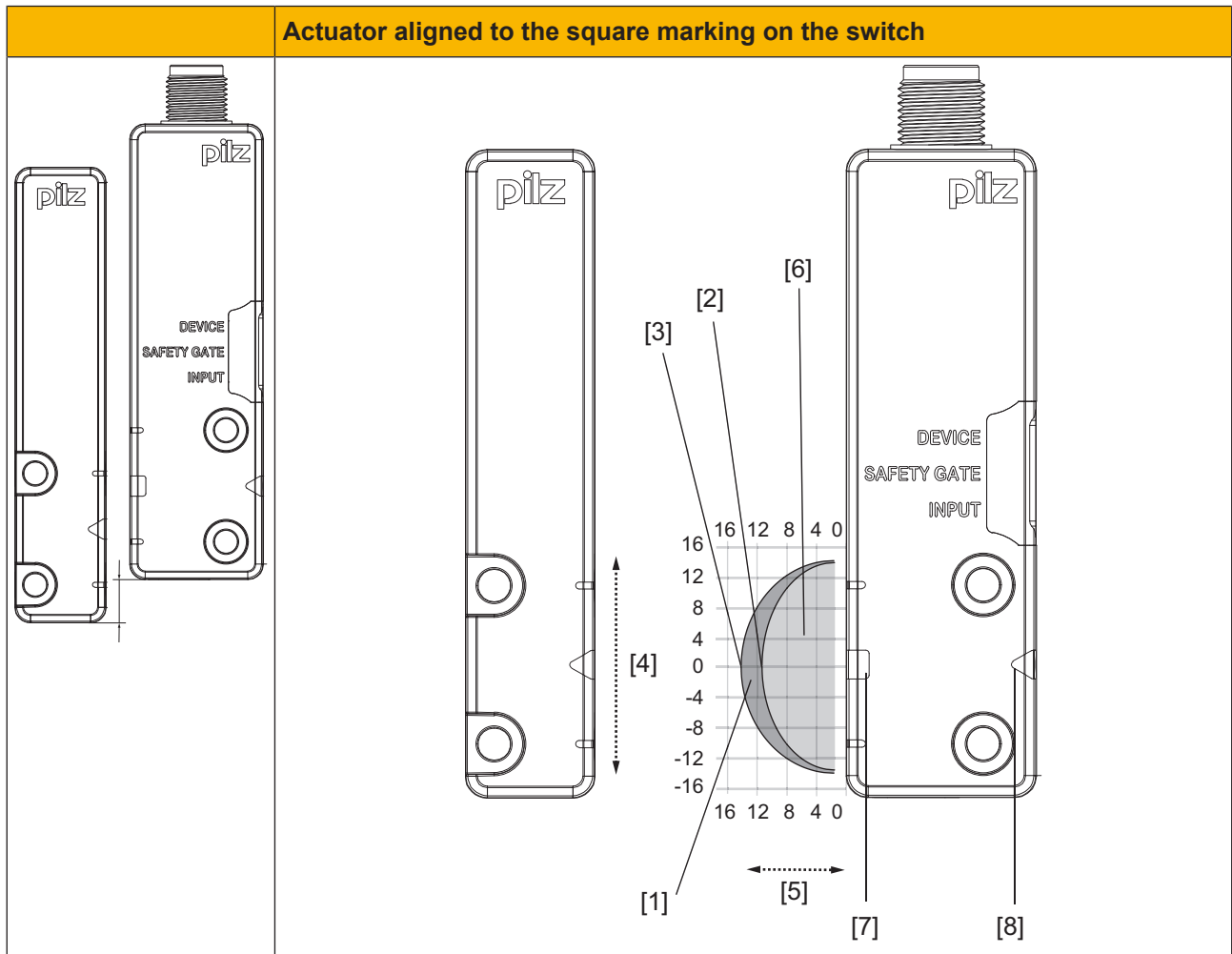

Legend

- [1] Hysteresis
- [2] Typical operating distance S_o
- [3] Typical release distance S_r
- [4] Offset in mm
- [5] Operating distance in mm
- [6] Response range
- [7] Status of LED
- [8] Square marking

Wiring

Important information

- ▶ Information given in the [Technical details \[22\]](#) must be followed.
- ▶ Switch off the supply voltage before disconnecting the plug-in connection.
- ▶ Make sure that when connecting or separating the connector the pollution degree 1 or 2 is maintained.
- ▶ The power supply must meet the regulations for extra low voltages with protective electrical separation (SELV, PELV).
- ▶ The outputs of the safety switch must have a protective separation to voltages over 60 V AC.
- ▶ The supply voltage to the safety switch must be protected with a 2 A to 4 A quick-acting fuse.
- ▶ Ensure the wiring and EMC requirements of EN 60204-1 are met.

Pin assignment, connector and cable

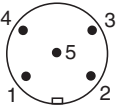
	5-pin M12 male connector
--	--------------------------

PIN	Pin designation	Function	Wire colour
1	A1	+24 V UB	brown
2	12	Output, channel1	white
3	A2	0 V UB	blue
4	22	Output, channel2	black
5	Y32	Signal output	grey

The wire colour also applies for the cable available from Pilz as an accessory.

Connection to evaluation devices

Make sure that the selected evaluation device has the following property:

- ▶ OSSD signals are evaluated through 2 channels with plausibility monitoring

Single connection



CAUTION!

Do not connect the signal output to 0 V!

If the signal output Y32 is connected to 0 V, the safety switch may be damaged as a result. Connect the signal output Y32 to a consumer, e.g. to the input on a control system, or leave the signal output unconnected. Also note the max. current (see [Technical details \[22\]](#)).

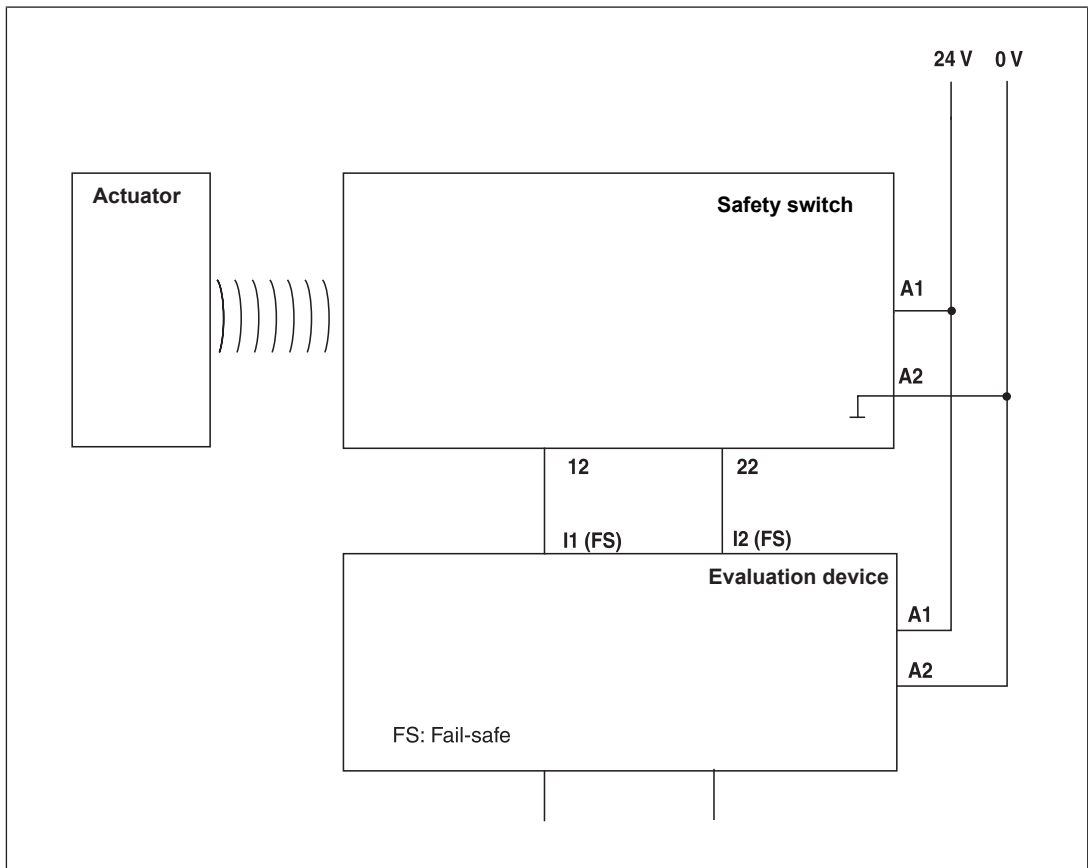

Teaching in the actuator

Any approved Pilz actuator (see [Intended use](#) [📖 6]) is detected as soon as it is brought into the response range.

Installation



CAUTION!

Potential loss of safety function due to changed device properties

The unit's properties may be affected if installed in an environment containing electrically or magnetically conductive material.

- Please check the operating distances and the assured release distance.

- ▶ The safety switch and actuator should be installed opposite each other in parallel. Make sure that the actuator is aligned to the square marking on the sensor (see [Operating distances](#) [📖 9]).
- ▶ Safety switches and actuators should only be secured using M4 screws with a flat head (e.g. M4 cheese-head or pan head screws).
- ▶ Torque setting: Please note the information provided under [Technical details](#) [📖 22].
- ▶ The distance between two safety switches must be maintained (see [Technical details](#) [📖 22]).

The distance can be undershot in certain application cases (see diagrams).

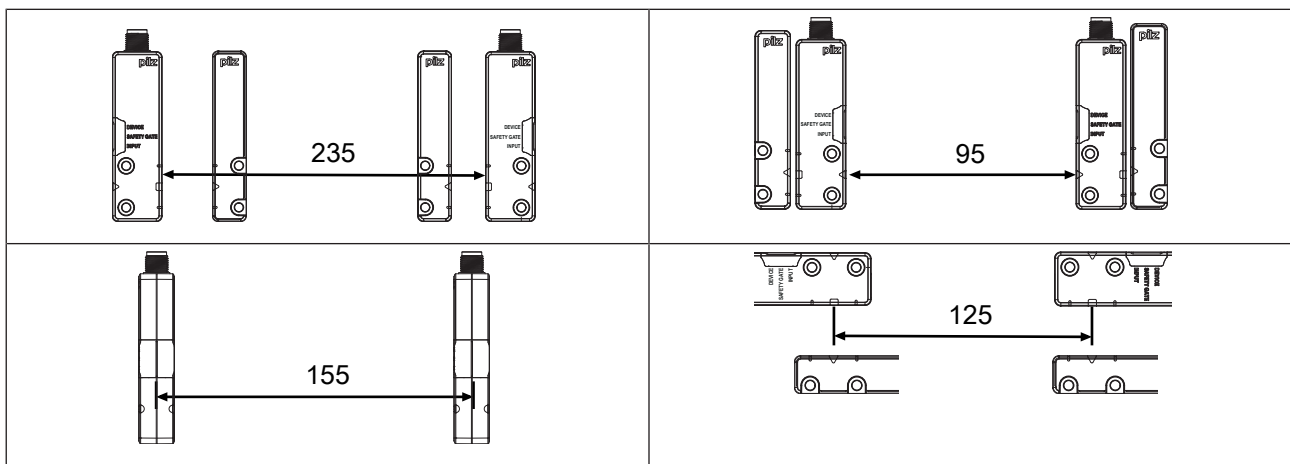

- ▶ If using angled connector plugs, note the defined angle of the cable routing.
- ▶ When installing make sure you comply with the requirements of EN ISO 14119.
- ▶ Make sure that the safety switch and actuator cannot be used as an end stop.
- ▶ For simpler installation, the mounting brackets (see [Order reference for Accessories](#) [📖 28]) can be used.
- ▶ The actuator should be protected from unauthorised removal and from contamination. Close the mounting holes using the seals provided (see diagrams). The use of seals should be regarded as equivalent to using permanent fastenings in accordance with EN ISO 14119.

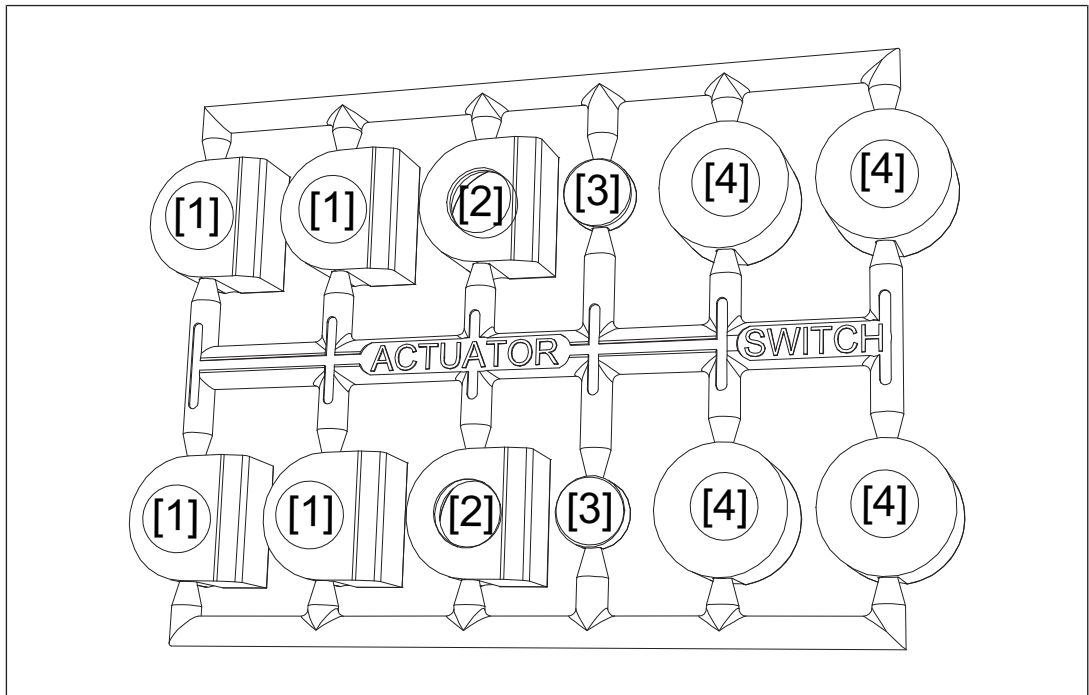

Fig.: Seals

[1]: 4 seals for actuators

[2]: 2 seals for actuators

[3]: 2 seals for actuators

[4]: 2 seals for switches and 2 seals for actuators

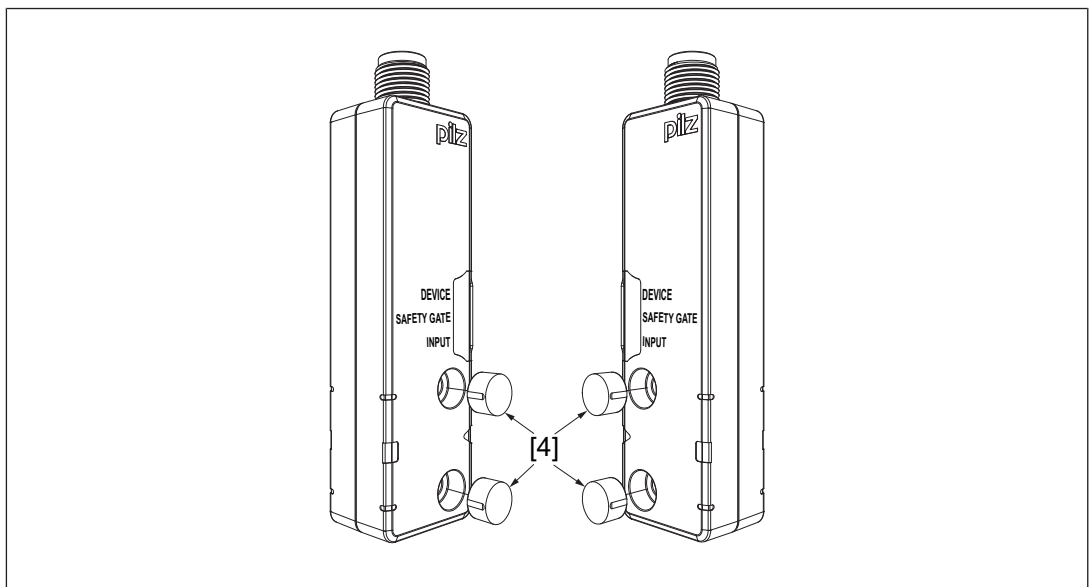

Fig.: Applying the screw cover [4] on the switch

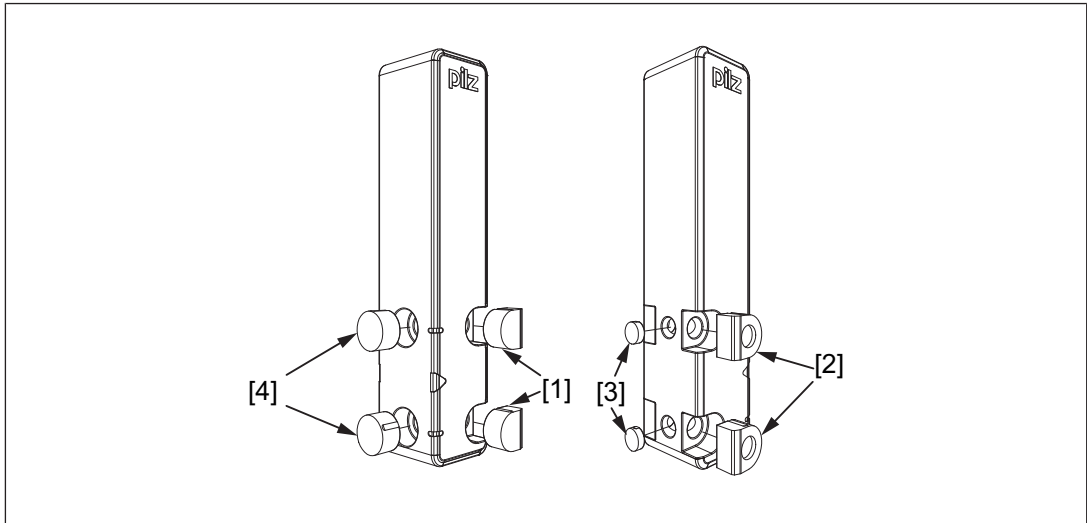

Fig.: Applying the screw covers [1] and [3] on the actuator

Procedure:

1. Drill holes (for M4 screws) in the mounting surface to secure the actuator and sensor (see [Dimensions in mm](#) 20).
2. Use a screw to fix the sensor to the mounting surface.
Make sure that the square marking on the sensor can be operated using the actuator from the right side.
3. Do not fully tighten the second screw on the safety switch.
4. Use a screw to fix the actuator to the mounting surface.
Make sure that the actuator with the triangle marking points towards the triangle marking on the sensor.
5. Do not fully tighten the second screw on the actuator.
6. Align the safety switch and tighten the screws.
7. Align the actuator and tighten the screws.

Use in operating heights higher than 2000 m above sea level

When using the PSEN cs5.11n note the reduced max. ambient temperature of +60 °C at a height of 2000 m to 4000 m.

Adjustment

- ▶ The stated operating distances (see [Technical details](#) 22) only apply when the safety switch and actuator are installed facing each other in parallel. Operating distances may deviate if other arrangements are used.
- ▶ Note the maximum permitted lateral and vertical offset (see [Operating distances](#) 9 and [Lateral and vertical offset](#) 11).

Operation



NOTICE

The safety functions should be checked after initial commissioning and each time the plant/machine is changed. The safety functions may only be checked by qualified personnel.

Status indicators:

Legend

- LED off
- ☀ LED on
- ◐ LED flashes (500 ms on, 500 ms off)
- ◑ LED flashes quickly (50 ms on, 950 ms off)

Normal mode

LED status		Switch status
Device	☀ green	Ready for operation
Safety gate	☀ yellow	Actuator is within the response range
	● Off	Actuator is outside the response range
Input	☀ yellow	The unit is ready for operation

Error display

LED status			Switch status	Remedy / measure
Device	Safety Gate	Input		
☀ Red	● off	● off	Internal error on switch	Change the switch.
◐ Red	◐ Yellow	◐ Yellow	Supply voltage is outside the tolerance range	Ensure the voltage supply corresponds to the Technical details [22] .
◐ Yellow	Display not definitive	Display not definitive	Supply voltage is at the limit of the tolerance range	Ensure the voltage supply corresponds to the Technical details [22] .
◐ Red	Display of last status	Display of last status	Outputs in fault condition	Check the outputs and switch the voltage off and then on again.
☀ Green	◑ Yellow	Display not definitive	Wrong actuator	Use the actuator that has been taught-in.
● off	◐ Yellow	◐ Yellow	Switch doesn't start	Change the switch.

Dimensions in mm

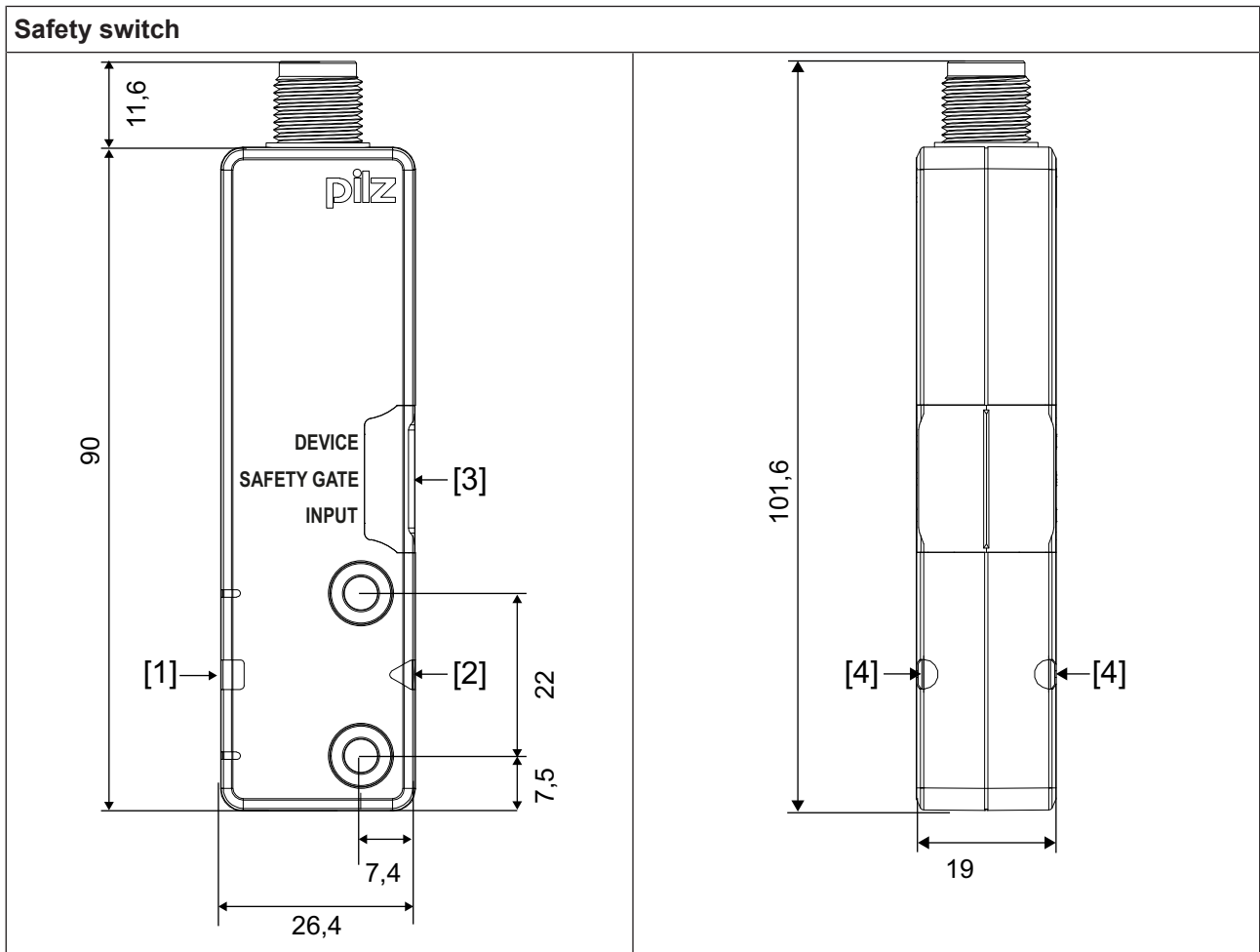

Actuator

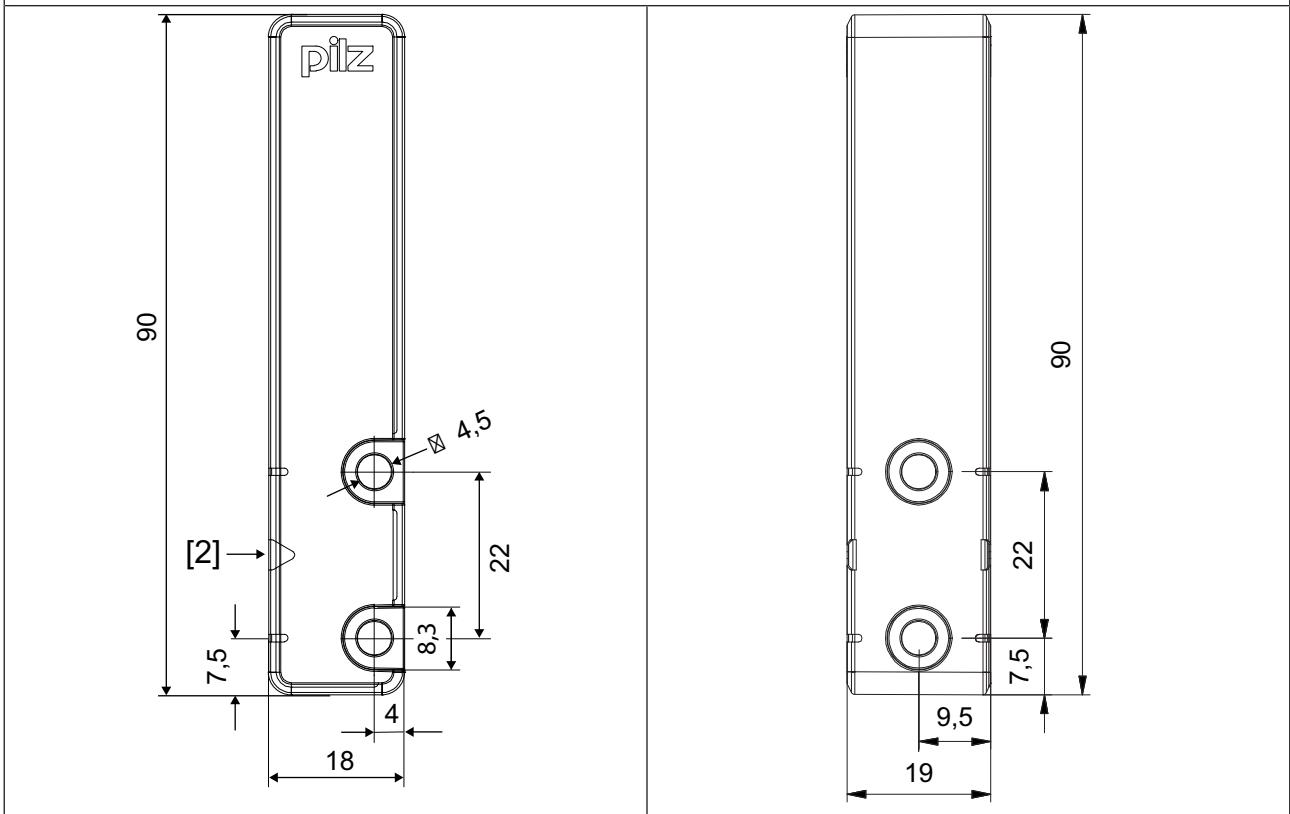

Legend:

- [1] Square marking
- [2] Triangle marking
- [3] LEDs
- [4] Semicircle marking

Technical details for safety switch

Where standards are undated, the 2025-09 valid editions apply.

General	
Certifications	CE, EAC, ECOLAB, FCC, IC, TÜV, UKCA, cULus Listed
Sensor's mode of operation	Transponders
Coding level in accordance with EN ISO 14119	Low
Design in accordance with EN ISO 14119	4
Classification in accordance with EN 60947-5-3	PDDB
Pilz coding type	coded
Transponders	
Frequency band	122 kHz - 128 kHz
Max. transmitter output	15 mW
Electrical data	
Supply voltage	
Voltage	24 V
Kind	DC
Voltage tolerance	-20 %/+20 %
Output of external power supply (DC)	1 W
Max. switching frequency	3 Hz
Max. cable capacitance at the safety outputs	
No-load, PNOZ with relay contacts	40 nF
PNOZmulti, PNOZelog, PSS	40 nF
Max. inrush current impulse	
Current pulse, A1	0,5 A
No-load current	25 mA
Semiconductor outputs	
OSSD safety outputs	2
Signal outputs	1
Switching current per output	100 mA
Breaking capacity per output	2,4 W
Potential isolation from system voltage	No
Short circuit-proof	Yes
Residual current at outputs	400 µA
Voltage drop at OSSDs	1 V
Conditional rated short circuit current	100 A
Lowest operating current	2 mA
Utilisation category in accordance with EN 60947-1	DC-12
Times	
Max. test pulse duration, safety outputs	150 µs

Times

Switch-on delay	
after UB is applied	1 s
Actuator typ.	30 ms
Actuator max.	50 ms
Delay-on de-energisation	
Actuator typ.	30 ms
Actuator max.	40 ms
Risk time in accordance with EN 60947-5-3	150 ms
Supply interruption before de-energisation	20 ms
Simultaneity, channel 1 and 2 max.	∞

Environmental data

Ambient temperature	
in accordance with the standard	EN 60068-2-14
Temperature range	-25 - 70 °C
Max. at max. operating height	+60 °C
Max. at operating height < 2000 m	+70 °C
Storage temperature	
in accordance with the standard	EN 60068-2-1/-2
Temperature range	-40 - 85 °C
Climatic suitability	
in accordance with the standard	EN 60068-2-30
Humidity	93 % r. h. at 40 °C
Max. operating height above SL	4000 m
EMC	EN 60947-5-3
Vibration	
in accordance with the standard	EN 60947-5-2
Frequency	10 - 55 Hz
Amplitude	1 mm
Shock stress	
in accordance with the standard	EN 60947-5-2
Acceleration	30g
Duration	11 ms
Airgap creepage	
Overvoltage category	III
Pollution degree	3
Rated insulation voltage	75 V
Rated impulse withstand voltage	1 kV
Protection type	
Housing	IP66, IP67

Operating distances

Repetition accuracy switching distances	3 %
Change of operating distance with temperature changes	+0,02mm/°C

Operating distances when the actuator approaches square marking

Assured operating distance S_{ao}	8 mm
Assured release distance S_{ar}	20 mm
Typical operating distance S_o	11 mm
Typical release distance S_r	14 mm
Typical hysteresis	2 mm

Mechanical data

Magnetic holding force between actuator and sensor	30 N
Actuator 1	PSEN cs5.11 M12
Min. distance between safety switches	250 mm
Sensor flush installation in accordance with EN 60947-5-2	yes, follow installation guidelines
Connection type	M12, 5-pin male connector
Material	PA+GF, PBT, polycarbonate
Max. fixing screws torque settings	1 Nm
Dimensions	
Height	26,4 mm
Width	101,6 mm
Depth	19 mm
Actuator dimensions	
Height	18 mm
Width	90 mm
Depth	19 mm
Weight of safety switch	75 g
Weight of actuator	60 g
Weight	75 g

Technical details actuator

General

Certifications	CE, EAC, ECOLAB, TÜV, UKCA, cULus Listed
Sensor's mode of operation	Transponders
Coding level in accordance with EN ISO 14119	Low
Pilz coding type	coded

Transponders

Frequency band	122 kHz - 128 kHz
----------------	-------------------

Environmental data

Ambient temperature	
in accordance with the standard	EN 60068-2-14
Temperature range	-25 - 70 °C
Max. at max. operating height	+60 °C
Max. at operating height < 2000 m	+70 °C

Environmental data

Storage temperature	
in accordance with the standard	EN 60068-2-1/-2
Temperature range	-40 - 85 °C
Climatic suitability	
in accordance with the standard	EN 60068-2-30
Humidity	93 % r. h. at 40 °C
Max. operating height above SL	4000 m
EMC	EN 60947-5-3
Vibration	
in accordance with the standard	EN 60947-5-2
Frequency	10 - 55 Hz
Amplitude	1 mm
Shock stress	
in accordance with the standard	EN 60947-5-2
Acceleration	30g
Duration	11 ms
Protection type	
Housing	IP66, IP67

Mechanical data

Magnetic holding force between actuator and sensor	30 N
Material	
Top	PBT
Max. fixing screws torque settings	1 Nm
Dimensions	
Height	18 mm
Width	90 mm
Depth	19 mm
Weight	60 g

Classification according to ZVEI, CB24I

The following tables describe the classes and specific values of the product interface and the classes of interfaces compatible with it. The classification is described in the ZVEI position paper "Classification of Binary 24 V Interfaces - Functional Safety aspects covered by dynamic testing".

Single-pole output**Interfaces**

Source	
Interface	Sensor
Class	C2
Drain	
Interface	Evaluation device
Class	C1, C2

Single-pole output

Source parameters

Max. test pulse duration	150 µs
Max. rated current	0,1 A
Max. capacitive load	40 nF

Safety characteristic data



NOTICE

You must comply with the safety characteristic data in order to achieve the required safety level for your plant/machine.

Operating mode	EN ISO 13849-1: 2023	EN ISO 13849-1: 2023	EN IEC 62061 SIL CL/max.	EN IEC 62061 61508	EN/IEC 61511 61508	EN/IEC 61511 61508	EN ISO 13849-1: 2023
	PL	Category	SIL	PFH [1/h]	SIL	PFD	T _M [year]
2-ch. OSSD	PL e	Cat. 4	SIL CL 3	9,56E-10	–	8,56E-06	20

Explanatory notes for the safety-related characteristic data:

- ▶ T_M is the maximum mission time in accordance with EN ISO 13849-1. The value also applies as the retest interval in accordance with EN IEC 61508-6 and EN IEC 61511 and as the proof test interval and mission time in accordance with EN IEC 62061.

All the units used within a safety function must be considered when calculating the safety characteristic data.



INFORMATION

A safety function's SIL/PL values are **not** identical to the SIL/PL values of the products used and may differ from these.

Supplementary data

Radio approval

USA/Canada

FCC ID: VT8-PSENCSS5
IC: 7482A-PSENCSS5

FCC/IC-Requirements:

This product complies with Part 15 of the FCC Rules and with Industry Canada licence-exempt RSS standards.

Operation is subject to the following two conditions:

- 1) this product may not cause harmful interference, and
- 2) this product must accept any interference received, including interference that may cause undesired operation.

Changes or modifications made to this product not expressly approved by Pilz may void the FCC authorization to operate this equipment.

NOTE: This equipment has been tested and found to comply with the limits for a Class A digital device, pursuant to Part 15 of the FCC Rules. These limits are designed to provide reasonable protection against harmful interference when the equipment is operated in a commercial environment. This equipment generates, uses, and can radiate radio frequency energy and, if not installed and used in accordance with the instruction manual, may cause harmful interference to radio communications. Operation of this equipment in a residential area is likely to cause harmful interference in which case the user will be required to correct the interference at his own expense.

Le présent produit est conforme aux CNR d'Industrie Canada applicables aux appareils radio exempts de licence. L'exploitation est autorisée aux deux conditions suivantes:

- (1) le produit ne doit pas produire de brouillage, et
- (2) l'utilisateur de le produit doit accepter tout brouillage radioélectrique subi, même si le brouillage est susceptible d'en compromettre le fonctionnement.

Order reference

Safety switch

Product type	Features		Order no.
PSEN cs5.11n 1switch	Safety switch, coded	5-pin M12 connector	542063

Actuator

Product type	Features		Order no.
PSEN cs5.11 M12 1actuator	Actuator, coded		542081

Complete systems

Product type	Features		Order no.
PSEN cs5.11n/ PSEN cs5.11 M12 1unit	Safety gate system, coded	5-pin M12 connector	542013

Accessories

Installation material

Product type	Features	Order no.
PSEN bracket	Mounting bracket	532110
PSEN mag/cs bracket straight	Mounting aid	532111
PSEN screw M4x20 10pcs	Safety screws made from stainless steel with one-way slot	540313
PSEN screw M4x26 10pcs	Safety screws made from stainless steel with one-way slot	540314
PSEN cs1/2 bracket cable fix	Mechanical protection against defeat, protecting against unauthorised cable disconnection or damage for safety switches PSENcode cs1/2, PSENcode cs5/6 M12, PSENslock	532112

Cable

Product type	Connection 1	Connection 2	Length	Order No.
PSS67/PDP67 cable M12-5sf	straight, M12, 5-pin, socket	straight, M12, 5-pin, connector	3 m	380208
			5 m	380209
			10 m	380210
			20 m	380220
			30 m	380211
PSS67/PDP67 cable M12-5af	Angled, M12, 5-pin, socket	Angled, M12, 5-pin, connector	3 m	380212
			5 m	380213
			10 m	380214
			30 m	380215
PSEN cable M12-5sf	straight, M12, 5-pin, socket	Open cable	3 m	630310
			5 m	630311
			10 m	630312
			20 m	630298
			30 m	630297
PSEN cable M12-5af	Angled, M12, 5-pin, socket	Open cable	3 m	630347
			5 m	630348
			10 m	630349
			30 m	630350

Connection

Product type	Features	Order no.
PDP67 F 8DI ION	Decentralised input module IP67 for PNOZmulti with M12 thread	773600
PDP67 F 8DI ION HP	Decentralised input module IP67 for PNOZmulti with M12 thread and additional supply voltage	773601
PDP67 F 8DI ION VA	Decentralised input module IP67 for PNOZmulti with M12 thread in stainless steel	773614
PDP67 F 8DI ION HP VA	Decentralised input module IP67 for PNOZmulti with M12 thread in stainless steel and additional supply voltage	773615

EC declaration of conformity

This product/these products meet(s) the requirements of the following directives of the European Parliament and of the Council.

- ▶ 2006/42/EC on machines
- ▶ 2014/53/EU on radio equipment

The complete EC Declaration of Conformity is available on the Internet at www.pilz.com/downloads.

Representative: Pilz GmbH & Co. KG, Felix-Wankel-Str. 2, 73760 Ostfildern, Germany

UKCA-Declaration of Conformity

This product(s) complies with following UK legislation:

- ▶ Supply of Machinery (Safety) Regulations 2008
- ▶ Radio Equipment Regulations 2017

The complete UKCA Declaration of Conformity is available on the Internet at www.pilz.com/downloads.

Representative: Pilz Automation Technology, Pilz House, Little Colliers Field, Corby, Northamptonshire, NN18 8TJ United Kingdom, eMail: mail@pilz.co.uk

Support

Technical support is available from Pilz round the clock.

Americas

Brazil

+55 11 97569-2804

Canada

+1 888 315 7459

Mexico

+52 55 5572 1300

USA (toll-free)

+1 877-PILZUSA (745-9872)

Asia

China

+86 400-088-3566

Japan

+81 45 471-2281

South Korea

+82 31 778 3390

Australia and Oceania

Australia

+61 3 95600621

New Zealand

+64 9 6345350

Europe

Austria

+43 1 7986263-444

Belgium, Luxembourg

+32 9 3217570

France

+33 3 88104003

Germany

+49 711 3409-444

Ireland

+353 21 4804983

Italy, Malta

+39 0362 1826711

Scandinavia

+45 74436332

Spain

+34 938497433

Switzerland

+41 62 88979-32

The Netherlands

+31 347 320477

Türkiye

+90 216 5775552

United Kingdom

+44 1536 460866

You can reach our international hotline on:

+49 711 3409-222

support@pilz.com

Pilz develops environmentally-friendly products using ecological materials and energy-saving technologies. Offices and production facilities are ecologically designed, environmentally-aware and energy-saving. So Pilz offers sustainability, plus the security of using energy-efficient products and environmentally-friendly solutions.



We are represented internationally. Please refer to our homepage www.pilz.com for further details or contact our headquarters.

Headquarters: Pilz GmbH & Co. KG, Felix-Wankel-Straße 2, 73760 Ostfildern, Germany
Telephone: +49 711 3409-0, E-Mail: info@pilz.com, Internet: www.pilz.com

PILZ
THE SPIRIT OF SAFETY

CECE, CHRE, CMSE®, INDUSTRIAL Pi®, Leansafe®, Myze®, PAS4000®, PAScal®, PASconfig®, Pilz®, PIT®, PMCPirimo®, PMCPirato®, PMCTiendo®, PMD®, PMi®, PNOZ®, Primo®, PSEN®, PSS®, PVIS®, SafetyBUS p®, SafetyNET p®, THE SPIRIT OF SAFETY® are registered and protected trademarks of Pilz GmbH & Co. KG in some countries. We would point out that product features may vary from the details stated in this document, depending on the status at the time of publication and the scope of the equipment. We accept no responsibility for the validity, accuracy and entirety of the text and graphics presented in this information. Please contact our Technical Support if you have any questions.

1004126-EN-05, 2025-12 Printed in Germany
© Pilz GmbH & Co. KG, 2024