



▶ PSEN cs3.1p Key

PILZ
THE SPIRIT OF SAFETY

Operating Manual-1005448-EN-04
- PSEN sensor technology



This document is the original document.

Where unavoidable, for reasons of readability, the masculine form has been selected when formulating this document. We do assure you that all persons are regarded without discrimination and on an equal basis.

All rights to this documentation are reserved by Pilz GmbH & Co. KG. Copies may be made for the user's internal purposes. Suggestions and comments for improving this documentation will be gratefully received.

CECE®, CHRE®, CMSE®, INDUSTRIAL PI®, Leansafe®, MYZEL®, PAS4000®, PAS-cal®, PASconfig®, Pilz®, PIT®, PMCprimo®, PMCprotego®, PM Ctendo®, PMD®, PMI®, PNOZ®, Primo®, PSEN®, PSS®, PVIS®, SafetyBUS p®, SafetyEYE®, SafetyNET p®, THE SPIRIT OF SAFETY® are registered and protected trademarks of Pilz GmbH & Co. KG in some countries.



SD means Secure Digital

Introduction	5
Validity of documentation	5
Using the documentation	5
Definition of symbols	5
Safety	6
Intended use	6
Safety regulations	7
Safety assessment	7
Additional documents that apply	7
Use of qualified personnel	8
Warranty and liability	8
Disposal	8
For your safety	9
Unit features	9
Function description	10
Basic function	10
Block diagram	11
Safety Device Diagnostics	11
Operating distances	12
Lateral and vertical offset	13
Wiring	15
Important information	15
Terminal assignment connectors	16
Connection to evaluation devices	16
Series connection	17
Connection to Pilz evaluation devices	21
Installation	22
Adjustment and testing	24
Operation	25
Dimensions in mm	25
Safety switch PSEN cs3.1p	25
Actuator	26
Adapter	26
Mounting bracket	26
Spacer	27

Technical details safety switch	28
Technical details actuator	31
Classification in accordance with ZVEI, CB24I	33
Safety characteristic data	34
Supplementary data	34
Radio approval	34
Order reference	35
Safety switch	35
Actuator	35
Accessories	35
EC declaration of conformity	38
UKCA-Declaration of Conformity	38

Introduction

Validity of documentation

This documentation is valid for the product PSEN cs3.1p Key from Version 3.0.

This operating manual explains the function and operation, describes the installation and provides guidelines on how to connect the product.

Using the documentation

This document is intended for instruction. Only install and commission the product if you have read and understood this document. The document should be retained for future reference.

Definition of symbols

Information that is particularly important is identified as follows:



DANGER!

This warning must be heeded! It warns of a hazardous situation that poses an immediate threat of serious injury and death and indicates preventive measures that can be taken.



WARNING!

This warning must be heeded! It warns of a hazardous situation that could lead to serious injury and death and indicates preventive measures that can be taken.



CAUTION!

This refers to a hazard that can lead to a less serious or minor injury plus material damage, and also provides information on preventive measures that can be taken.



NOTICE

This describes a situation in which the product or devices could be damaged and also provides information on preventive measures that can be taken. It also highlights areas within the text that are of particular importance.

**INFORMATION**

This gives advice on applications and provides information on special features.

Safety**Intended use**

The safety functions of the safety switch are:

- ▶ Safe shutdown of safety outputs when the actuator is removed beyond the assured release distance s_{ar} or when the actuator is not detected
- ▶ Remain shut down safely after the actuator has been removed

The safety switch meets the requirements in accordance with:

- ▶ EN 60947-5-3: PDDB with one of the approved actuators
- ▶ EN 62061: SIL CL 3
- ▶ EN ISO 13849-1: PL e (Cat. 4)
- ▶ EN ISO 14119: Coding level Low, type 4

The safety switch may only be used with one of the approved actuators.

The safety level PL e (Cat. 4)/SIL CL 3 is achieved only when:

- ▶ the safety outputs use 2-channel processing.

The user is responsible for incorporating the device correctly into one overall system. The overall system must be validated in a safety assessment in accordance with the Machinery Directive.

Improper use

The following is deemed improper use in particular:

- ▶ Any component, technical or electrical modification to the product,
- ▶ Use of the product outside the areas described in this operating manual,
- ▶ Use of the product outside the technical details (see chapter entitled [Technical Details](#) [ 28]).

**NOTICE****EMC-compliant electrical installation**

The product is designed for use in an industrial environment. The product may cause interference if installed in other environments. If installed in other environments, measures should be taken to comply with the applicable standards and directives for the respective installation site with regard to interference.

Approved actuators:

- ▶ PSEN cs4.1 Key gy1
- ▶ PSEN cs4.1 Key gy2
- ▶ PSEN cs4.1 Key gy3
- ▶ PSEN cs4.1 Key gy4
- ▶ PSEN cs4.1 Key bl

Safety regulations

Safety assessment

Before using a product, a risk assessment in accordance with the Machinery Directive is required.

The product as an individual component fulfils the functional safety requirements in accordance with EN/IEC 61508, EN ISO 13849-1/2 and EN IEC 62061. However, this does not guarantee the functional safety of the overall plant/machine. To achieve the relevant safety level of the overall plant/machine's required safety functions, each safety function needs to be considered separately.

It is the responsibility of the user/operator to carry out a risk assessment for their application, in which they consider the impact of assumed errors in the wiring and take appropriate measures to control or avoid these errors.

Additional documents that apply

Please read and take note of the following documents.

Only for use of the Safety Device Diagnostics (SDD):

- ▶ Fieldbus module operating manual, SDD ES PROFINET (1003826) for example
- ▶ System description Safety Device Diagnostics (1003827)

For the use of passive junctions:

- ▶ Operating manual of a passive junction, for example:
 - PSEN ix2 F4 code
 - PSEN ix2 F8 code
 - PDP67 F 4 code
 - PSEN Y junction M12 sensor
 - PSEN Y junction M12 cable

You will need to be conversant with the information in these documents in order to fully understand this operating manual.

Use of qualified personnel

The products may only be assembled, installed, programmed, commissioned, operated, de-commissioned and maintained by persons who are competent to do so.

A competent person is a qualified and knowledgeable person who, because of their training, experience and current professional activity, has the specialist knowledge required. In order to inspect, assess and handle products, devices, systems, plant and machinery, this person must be familiar with the state of the art and the applicable national, European and international laws, directives and standards.

It is the company's responsibility only to employ personnel who

- ▶ Are familiar with the basic regulations concerning health and safety / accident prevention,
- ▶ Have read and understood the information provided in the section entitled Safety
- ▶ Have a good knowledge of the generic and specialist standards applicable to the specific application.

Warranty and liability

All claims to warranty and liability will be rendered invalid if

- ▶ The product was used contrary to the purpose for which it is intended,
- ▶ Damage can be attributed to not having followed the guidelines in the manual,
- ▶ Operating personnel are not suitably qualified,
- ▶ Any type of modification has been made (e.g. exchanging components on the PCB boards, soldering work etc.).

Disposal

- ▶ In safety-related applications, please comply with the mission time T_M stated in the safety-related characteristic data.
- ▶ When decommissioning, please comply with local regulations regarding the disposal of electronic devices (e.g. Electrical and Electronic Equipment Act).

For your safety**WARNING!****Loss of safety function due to manipulation of the interlocking device**

Manipulation of the interlocking device may lead to serious injury and death.

- You should prevent any possibility of the interlocking device being manipulated through the use of a spare actuator.
- Keep the substitute actuator in a safe place and protect it from unauthorised access.
- If substitute actuators are used, these must be installed as described under [Installation](#) [22].
- If the original actuators are replaced with substitute actuators, the original actuators must be destroyed before disposal.

- ▶ Do not remove the connector's protective cap until you are just about to connect the product. This will prevent potential contamination.

Unit features

- ▶ Transponder technology for presence detection
- ▶ Pilz coding type: coded
- ▶ Dual-channel operation
- ▶ 2 safety inputs for series connection of multiple safety switches
- ▶ 2 safety outputs
- ▶ Safety Device Diagnostics (SDD)
 - Safety Device Diagnostics can be used to retrieve sensor information on one or more sensors, to perform actions and to read and write configuration parameters.
 - Manipulation protection in accordance with ISO 14119 is possible by verifying the short name of the actuator through the controller via SDD communication
- ▶ Diagnostic input for Y1 for Safety Device Diagnostics (SDD)
- ▶ Signal output/diagnostic output Y32 for Safety Device Diagnostics
- ▶ LED display for:
 - State of the actuator
 - State of the inputs
 - Supply voltage/fault
- ▶ 1 direction of actuation

Function description

Basic function

The safety outputs may have a high or low signal, depending on the position of the actuator and the signal status of the inputs.

In a safe condition the safety outputs are in the OFF state.

Electrical states of the inputs and outputs (when safety switch is ready for operation: Power/Fault LED is green):

Actuator within the response range	Safety input S11	Safety input S21	Safety output 12	Safety output 22	Signal output Y32 (without use of the SDD)
Yes	High	High	High	High	High
Yes	Low	Low	Low	Low	High
No	x	x	Low	Low	Low
Yes	High	Low	High	Low	High
Yes	Low	High	Low	High	High

x: High or low signal

Plausibility monitoring for safety inputs S11 and S21

- ▶ If one safety input switches from high to low, while the other safety input remains high, an unequal status is displayed: **Input LED flashes yellow**
- ▶ If this safety input switches back from low to high, while the other safety input remains high, a plausibility error is displayed and a partial operation lock is triggered: **Input LED flashes yellow**

A switch to a high signal will only lead to normal safety switch operation if both inputs had a low signal. From this moment on, the switch to high may occur (partial operation lock see [Error display \[25\]](#)).

▶ Diagnostic input Y1

If an SDD fieldbus module is used, the diagnostic input Y1 is automatically activated and data is read.

If no SDD fieldbus module is used, the diagnostic input Y1 is not used.

▶ Signal output/diagnostic output Y32 in SDD mode

If an SDD fieldbus module is used, the signal output/diagnostic output Y32 is activated for writing data.

Block diagram

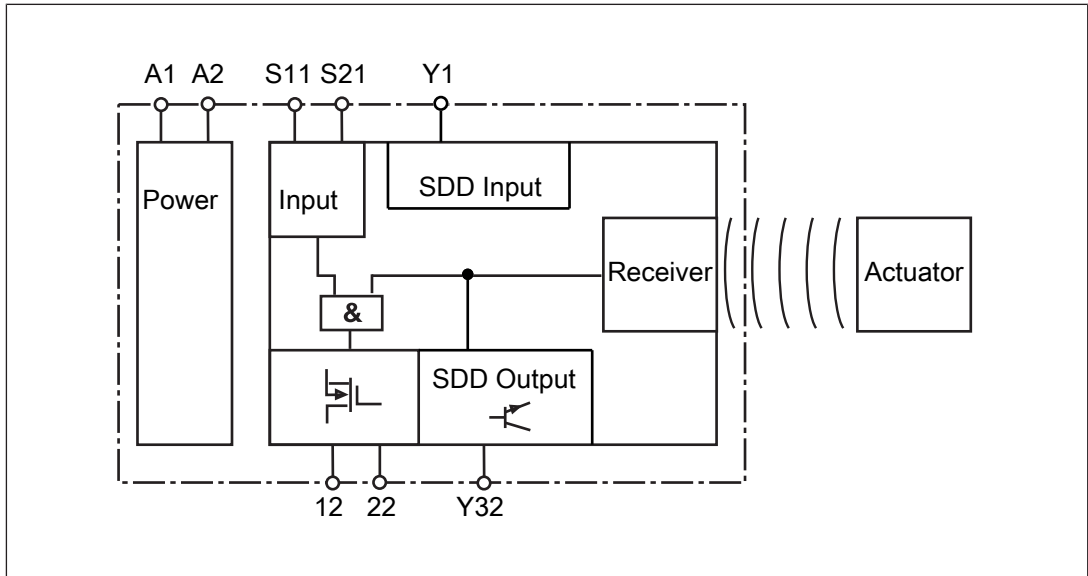

Safety Device Diagnostics

Safety Device Diagnostics is an option that can be selected independently of the safety-related wiring.

When using the Safety Device Diagnostics, up to 16 sensors connected in series can be connected as a subscriber to a fieldbus module.

The communication of the sensors with the fieldbus module is automatically built up again with each new supply of the supply voltage. As a result, a sensor can be exchanged, e.g. when servicing, without the need for special measures.

Any exchange can be detected via the fieldbus module, through the serial number for example.

► With Safety Device Diagnostics there are the following diagnostic options for the fieldbus module:

- Poll information of the sensors (examples: what sensor in the series has switched, at what point could there be an open circuit in the series connection)
- Read configuration parameters of the sensor (examples: Number of teach-in processes remaining, serial number of the sensor)
- Perform actions (example: poll updated actuator name)

The results of the sensor diagnostics can be checked already during the installation phase via the display in the fieldbus module, without the need to connect the fieldbus module to the network.

► With Safety Device Diagnostics there are the following diagnostic options for the fieldbus module for simple wiring:

- Information is passed on via the fieldbus module directly to the network
- Mappings of the signal outputs to the sensor are automated by the SDD.

This prevents wiring errors and an expansion or reduction of the sensors is possible without the need to change existing wiring.

- Wiring in accordance with IP20: Rapid installation in the control cabinet is enabled.
- Wiring in accordance with IP67: Various passive junctions can be used (see [Order references for accessories \[35\]](#)) to connect several sensors with only one cable from the field in the control cabinet.

Further information on Safety Device Diagnostics can be found in [Additional documents that apply \[7\]](#).

Operating distances

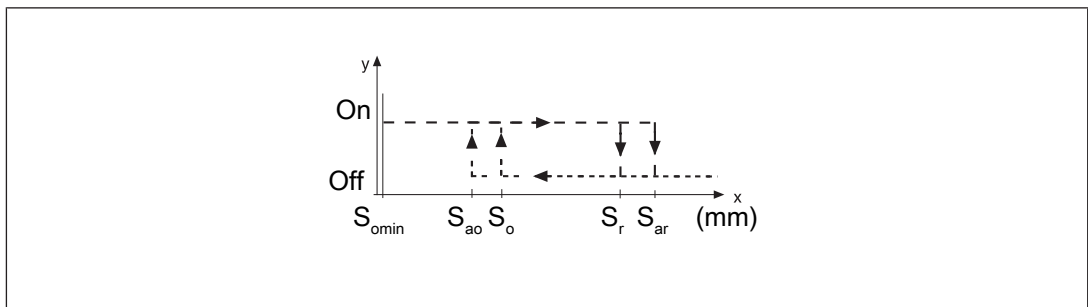

Legend

- S_{ao} Assured operating distance
- S_{omin} Min. operating distance
- S_{ar} Assured release distance

The offset-independent values for the switching distances are included in the [Technical details \[28\]](#).

Lateral and vertical offset

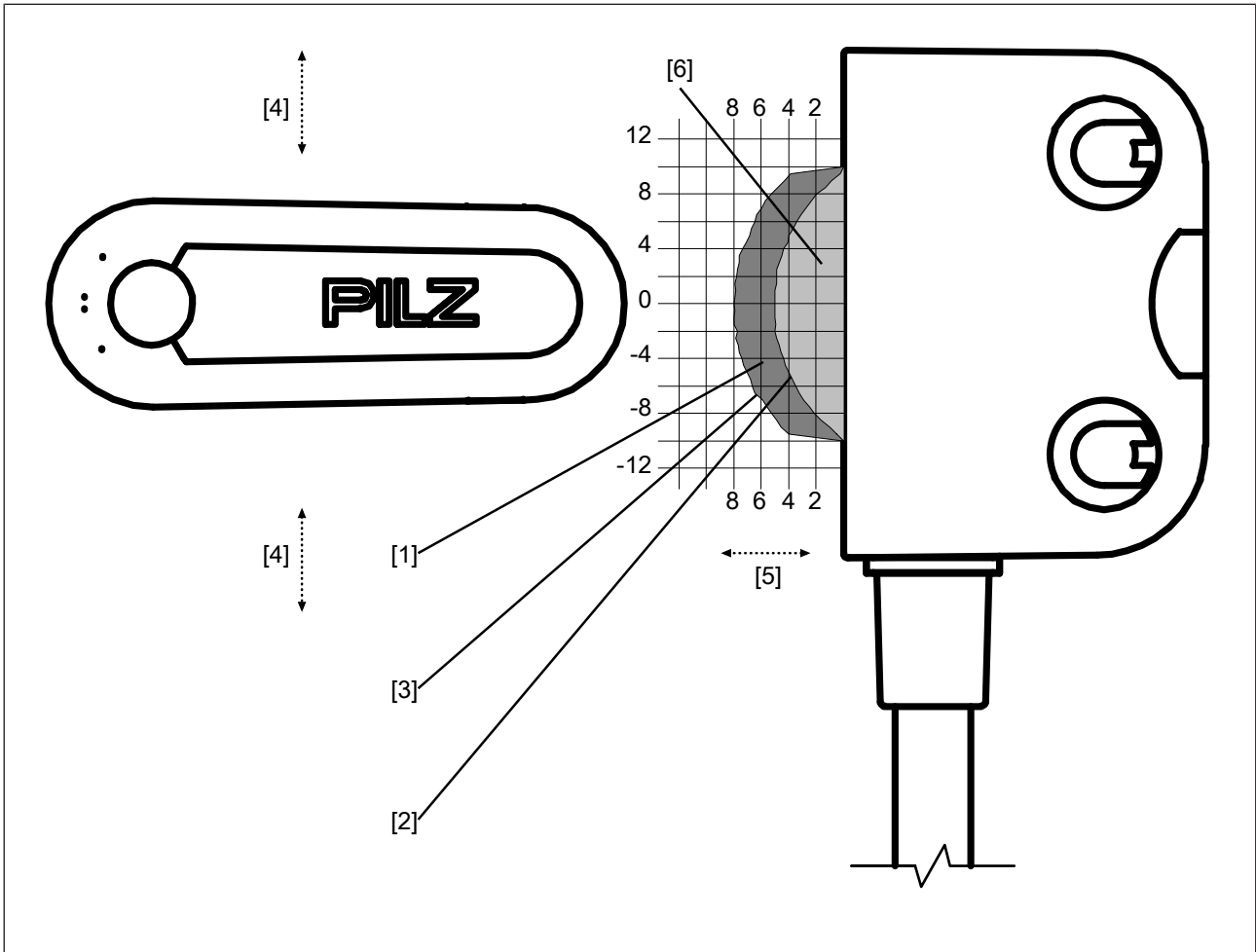

Fig.: Lateral offset: safety switch PSEN cs3.1p Key with actuator PSEN cs4.1 Key gy or PSEN cs4.1 Key bl

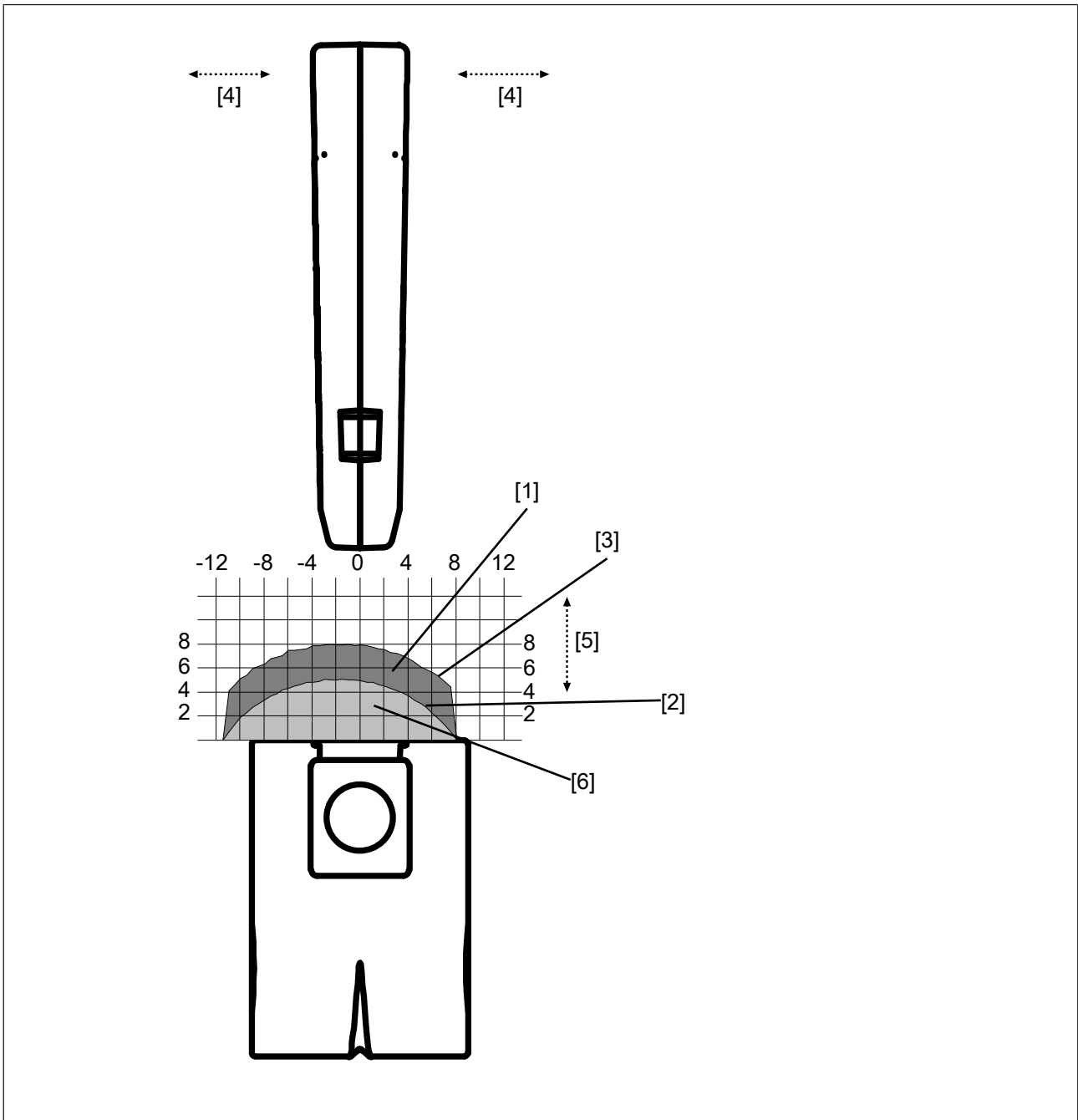

Fig.: Vertical offset: safety switch PSEN cs3.1p Key with actuator PSEN cs4.1 Key gy or PSEN cs4.1 Key bl

Legend

- [1] Hysteresis
- [2] Typical operating distance S_o
- [3] Typical release distance S_r
- [4] Offset in mm
- [5] Operating distance in mm
- [6] Response range

Wiring

Important information

- ▶ Information given in the [Technical details \[28\]](#) must be followed.
- ▶ Switch off the supply voltage before disconnecting the plug-in connection.
- ▶ Make sure that when connecting or separating the connector the pollution degree 1 or 2 is maintained.
- ▶ The max. cable length l_{\max} in the input circuit is calculated from
 - the max. cable capacitance at the safety outputs (see [Technical data \[28\]](#)).
 - the minimum permitted supply voltage at the safety switch (19.2 V).
- ▶ The power supply must meet the regulations for extra low voltages with protective electrical separation (SELV, PELV).
- ▶ The power supply must have an overvoltage protection of ≤ 35 V DC.



INFORMATION

Only use safety relays with a 24 VDC supply voltage. Safety relays with a wide-range power supply or in AC device versions have internal potential isolation and are not suitable as evaluation devices.

- ▶ The supply voltage to the safety switch must be protected with a 2 A to 4 A quick-acting fuse.
- ▶ Ensure the wiring and EMC requirements of EN 60204-1 are met.
- ▶ When connecting in series, consider the requirements of manipulation protection and the protection against bypassing or from overriding the safety switch (EN ISO 14119).
- ▶ When the safety inputs of the safety switch are controlled by an upstream device, and they are not wired with 24 V,
 - They must be monitored for shorts across contacts (e.g. by PSEN cs, PSEN ml, PSEN sg or PSEN sl) **or**
 - The faults at the safety inputs that can occur by shorts across contact will have to be excluded by suitable measures (e.g. wiring in accordance with EN 602041).

Terminal assignment connectors

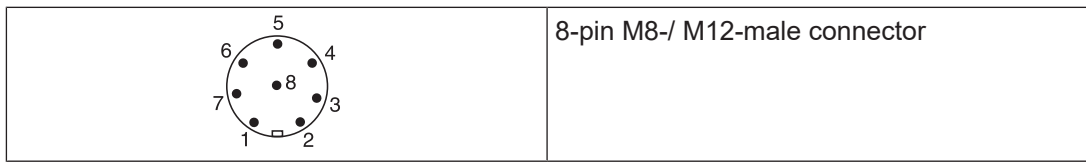

PIN	Connection designation	Function	Wire colour
1	S21	Input, channel 2	white
2	A1	+24 VUB	brown
3	12	Output, channel1	green
4	22	Output, channel2	yellow
5	Y32	Signal output/diagnostic output	grey
6	S11	Input, channel 1	pink
7	A2	0 V UB	blue
8	Y1	Diagnostics input	red

The wire colour also applies for the cable available from Pilz as an accessory.

Connection to evaluation devices

Make sure that the selected evaluation device has the following property:

- ▶ OSSD signals are evaluated through 2 channels with plausibility monitoring

Note:

- ▶ Information given in the [Technical details \[28\]](#) must be followed.
- ▶ The use of Safety Device Diagnostics is described in detail in the Safety Device Diagnostics System Description (1003827).



CAUTION!

Do not connect the signal output to 0 V!

If the signal output Y32 is connected to 0 V, the safety switch may be damaged as a result. Connect the signal output Y32 to a consumer, e.g. to the input on a control system, or leave the signal output unconnected. Also note the max. current (see [Technical details \[28\]](#)).

Series connection

The safety sensors PSENcode are also suitable for series connection with other sensors.

Maximum number of PSENcode sensors in series connections for SIL CL 3

- ▶ PSENcode compact design (PSEN cs3 – cs4, 8-pin): 12

If other sensors are used, the number must be recalculated.

In practice, the maximum possible number will be limited by the following parameters, among others:

- ▶ The required SIL level (e.g. SIL CL 3),
- ▶ the required performance level (e.g. PL e (Cat. 4)),
- ▶ the maximum delay or risk time permitted by the application.

Ensure there is sufficient supply voltage, taking inrush currents and fusing into consideration.



CAUTION!

Extension of delay-on de-energisation

When several (n) devices are connected in series, the delay-on de-energisation time adds with the number of interconnected safety switches.

The max. delay-on de-energisation is made up of the risk time (see [Technical details \[28\]](#))

+ (n-1) x max. delay-on de-energisation of the inputs
+ max. delay-on de-energisation of the evaluation device

- ▶ When making series connections using SDD, only use the following passive junctions.
 - PSEN ix2 F4 code
 - PSEN ix2 F8 code
 - PSEN Y junction M8-M12/M12 PIGTAIL
 - PSEN Y junction M12-M12/M12 PIGTAIL
 - PSEN Y junction M12 SENSOR
 - PSEN Y junction M12 cable channel
 - PSEN Y junction M8 SENSOR
 - PSEN Y junction M8 cable channel

Function test when safety channels are connected in series

Before commissioning and after each change, check that the safety function is guaranteed when the gates are opened. To do this, open each gate individually and check the status at the inputs on the evaluation device:

- ▶ Close all the gates.

There must be high signals at the inputs on the evaluation device (e.g. S11, S21 or I1, I2).

- ▶ Open one gate; the other gates remain closed.

There must be low signals at the inputs on the evaluation device (e.g. S11, S21 or I1, I2).

- ▶ Close the gate again.

High signals must return at the inputs on the evaluation device (e.g. S11, S21 or I1, I2).

- ▶ Repeat the test for each gate.

- ▶ If the input signals do not react as described above, check and rectify the wiring and carry out the test again.

Connection diagram, series connection without SDD

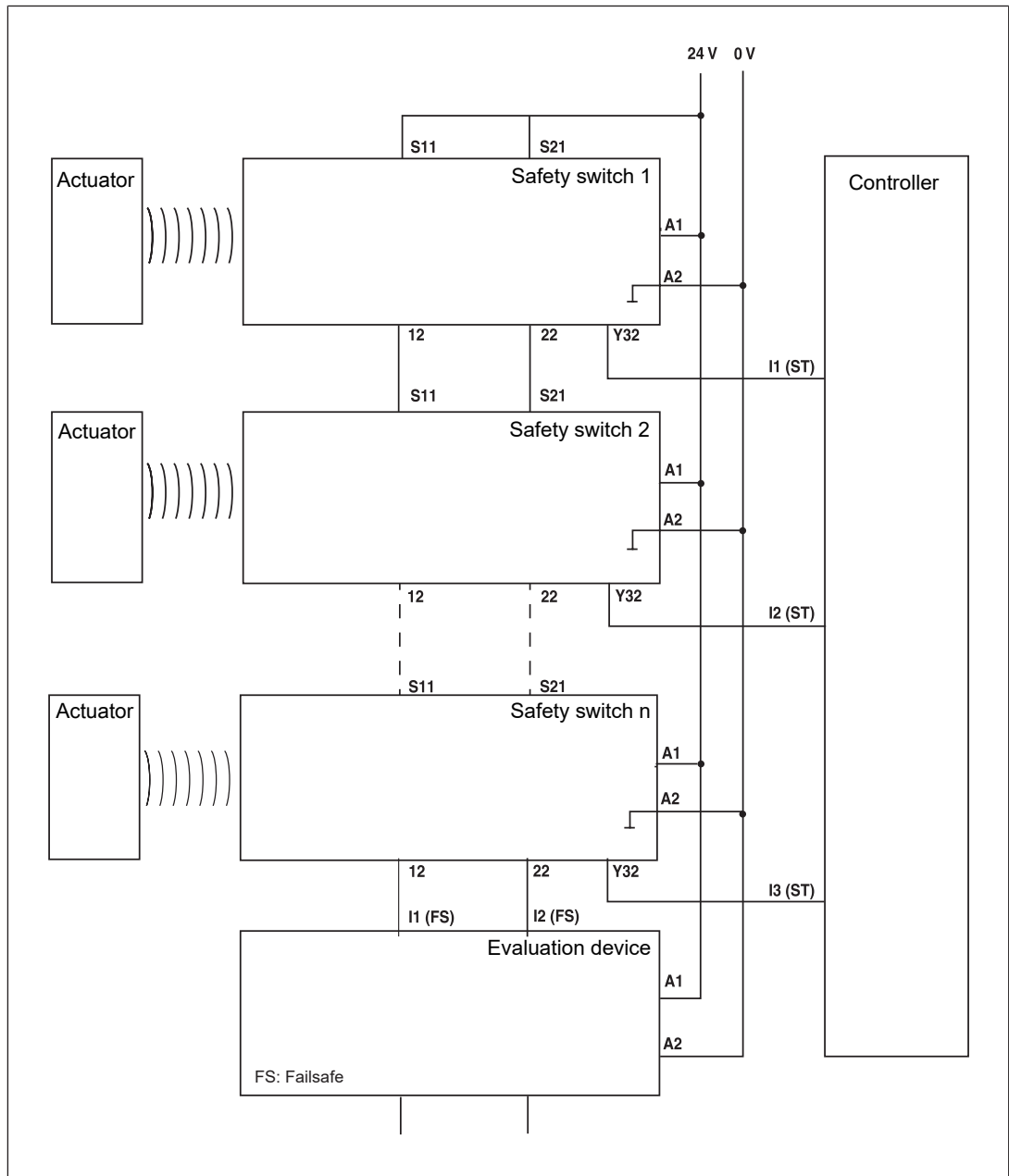

Connection diagram, series connection with SDD

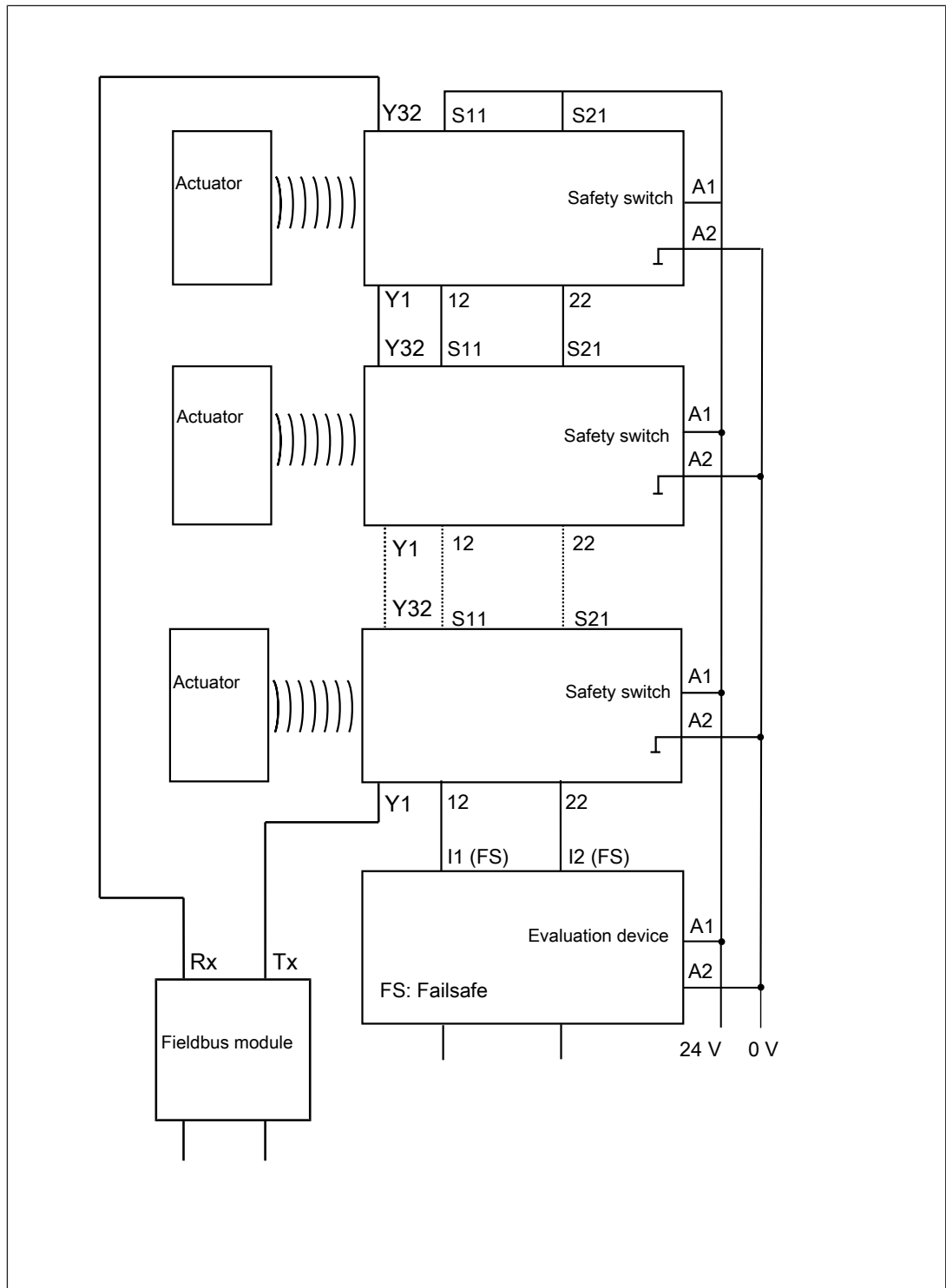

Connection to Pilz evaluation devices

The safety switch PSEN cs3.1p Key can be connected to Pilz evaluation devices, for example.

Suitable Pilz evaluation devices are, for example:

- ▶ PNOZelog for safety gate monitoring
- ▶ PNOZpower for safety gate monitoring
- ▶ PNOZsigma for safety gate monitoring
- ▶ PNOZ X for safety gate monitoring
- ▶ PNOZmulti for safety gate monitoring
Configure the safety switch in the PNOZmulti Configurator with switch type 3.
- ▶ PSS for safety gate monitoring with standard function block SB064, SB066 or FS_Safety Gate

The correct connection to the respective evaluation device is described in the operating manual for the evaluation device. Make sure that the connection is made in accordance with the specifications in the operating manual for the selected evaluation device.

The connections to two evaluation devices are shown on the following pages, by way of example:

- ▶ PNOZ s3 and
- ▶ PNOZmulti

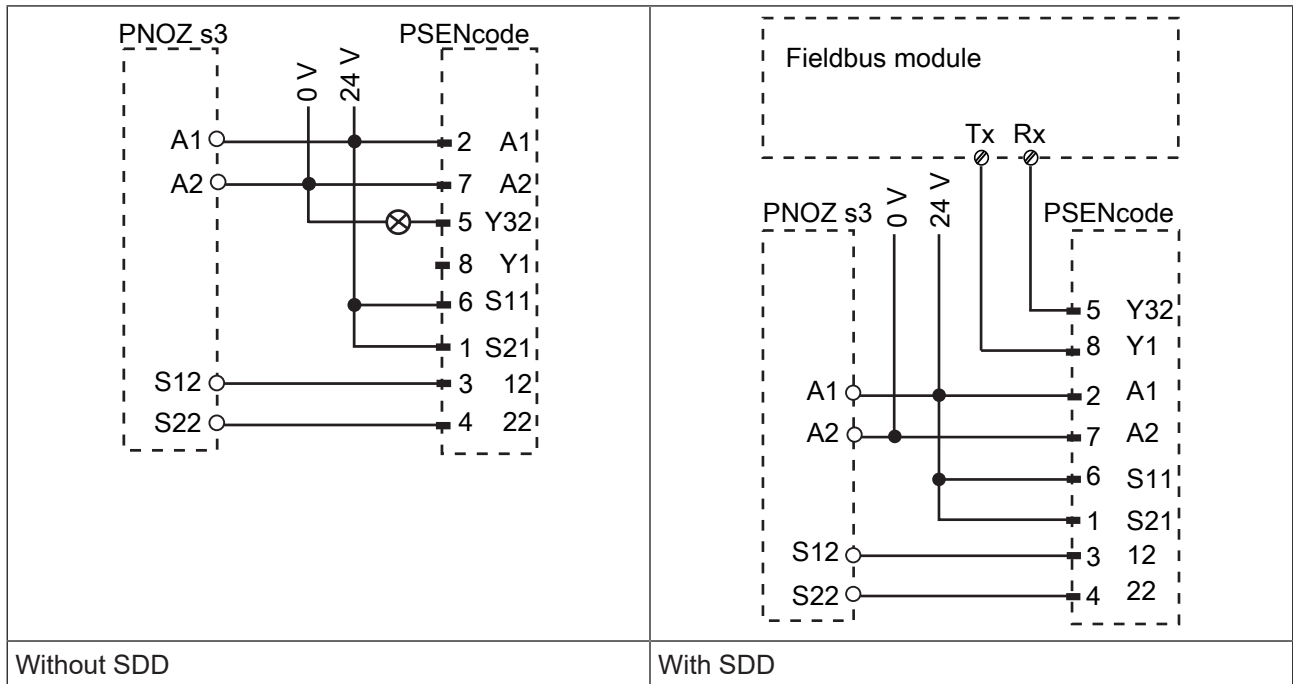

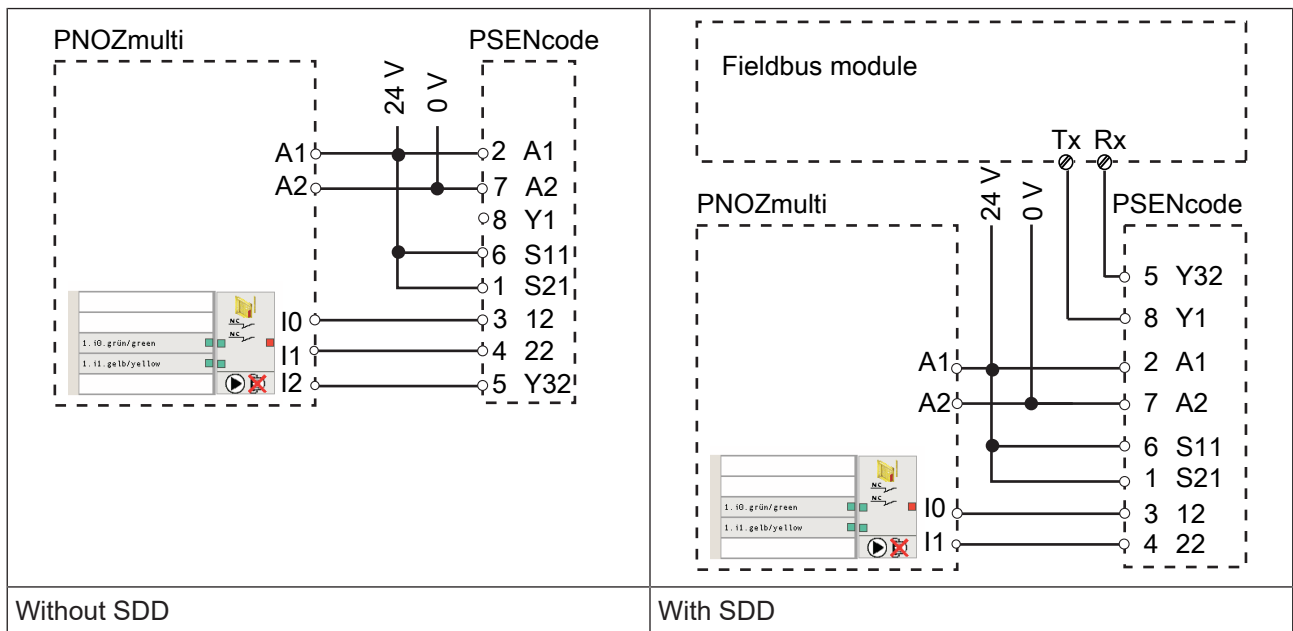

Installation



WARNING!

Possible loss of safety function due to processing data from the wrong actuator!

The distance between two safety switches must be maintained (see Technical details).

A shorter distance is possible if the safety switches are shielded from each other.

A safety switch must not receive and process any signals from the actuator of another safety switch.



CAUTION!

The unit's properties may be affected if installed in an environment containing electrically or magnetically conductive material. Please check the operating distances and the assured release distance.

- ▶ Install the safety switch flush to the adapter.
 - ▶ To fasten the safety switch securely, use the mounting device for PSEN cs key or a suitable bracket.
- Ensure that the distance from the sensing face of the safety switch to the sensing face of the PSEN cs key adapter V does not exceed the assured release distance $S_{ar,r}$ (see [Technical details](#) [28]).
- ▶ Torque setting: Please note the information provided under [Technical details](#) [28].

- ▶ Make sure that the safety switch and actuator cannot be used as an end stop.
- ▶ Prevent the safety switch and actuator being exposed to heavy shock or vibration.
- ▶ When installed on metal surfaces, the operating distance may be greatly reduced. For this reason, Pilz recommends you comply with the following thicknesses for the mounting surface:
 - Non-metal surface: 4.5 mm
 - Metal surface: 2.5 mm.

The values include the bracket and apply also when using the spacer.

Procedure:

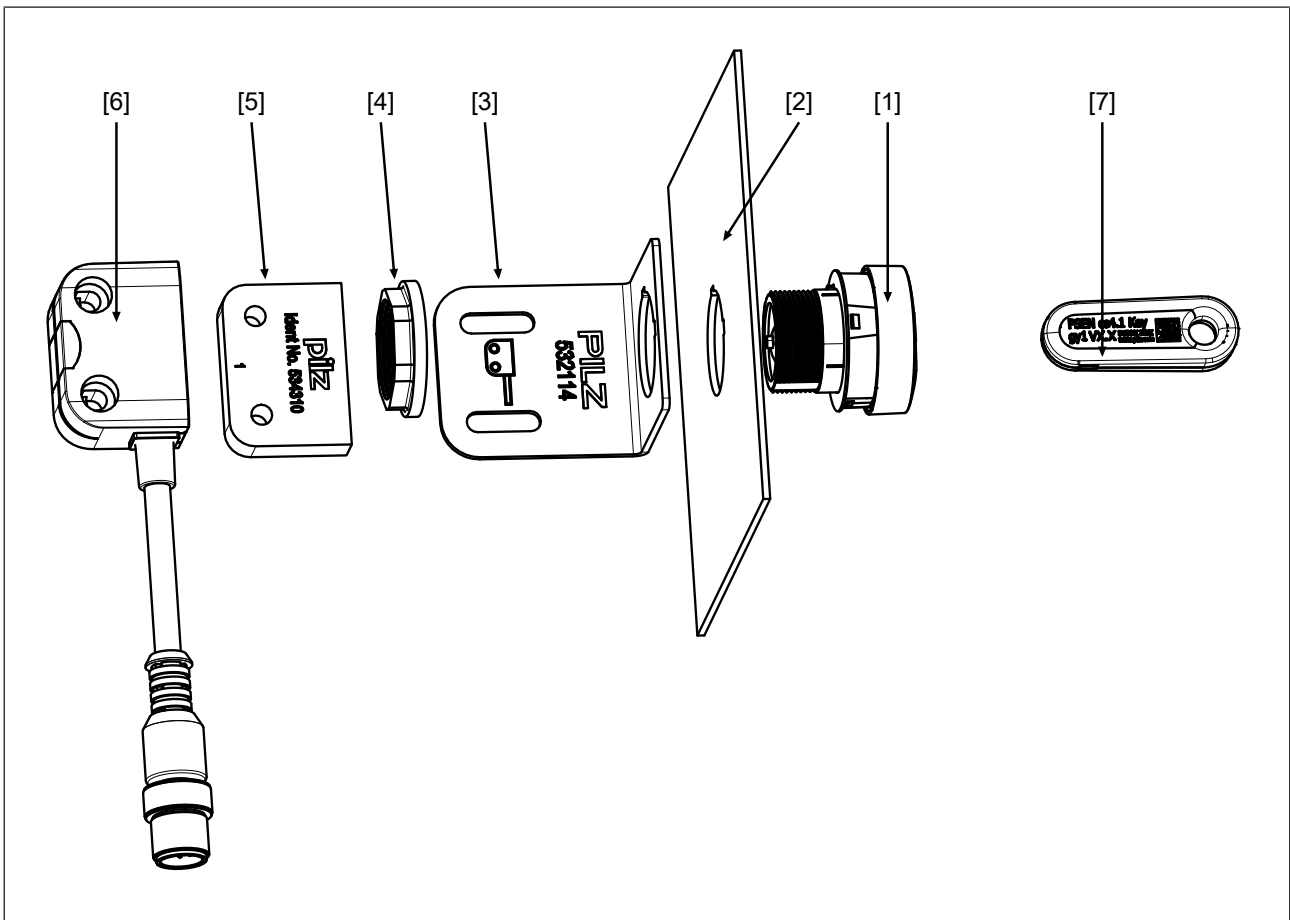



Fig.: Installing PSEN cs key adapter V, PSEN cs key adapter bracket and PSEN cs4.1 Key - Exploded drawing

Legend

- [1] PSEN cs key adapter V
- [2] Mounting surface
- [3] Mounting bracket PSEN cs key adapter bracket
- [4] Plastic nut M22 for PSEN cs key adapter V
- [5] PSEN spacer
- [6] PSEN cs4.1 Key
- [7] Actuator PSEN cs4.1 Key gy or PSEN cs4.1 Key bl

1. Provide the mounting surface [2] with a drill hole (\varnothing 22.5 mm) for fastening the adapter (see [Dimensions](#)  25).
2. Insert the adapter [1] into the drill hole in the mounting surface [2].
3. Fasten the adapter to the mounting surface.

Using the mounting bracket PSEN bracket [3]:

Guide the adapter through the drill holes in the mounting surface and mounting bracket and fasten it from the other side using the plastic nut [4] (M22). Note the torque setting from min. 1.3 Nm to max. 2.1 Nm. We recommend that you use the installation wrench PIT es wrench to fasten the plastic nut (see [Order reference](#)  35).

Without mounting bracket PSEN bracket:

Guide the adapter through the drill hole in the mounting surface and fasten it from the other side using the plastic nut [4] (M22). Note the torque setting from min. 1.3 Nm to max. 2.1 Nm. We recommend that you use the installation wrench PIT es wrench to fasten the plastic nut (see [Order reference](#)  35)

4. Fasten the PSEN cs to the mounting bracket or another suitable bracket.

Using the mounting bracket PSEN bracket:



Use two screws and nuts (Pilz recommends M4x30) to fasten the safety switch [6] and spacer [5] to the mounting bracket PSEN bracket [3] (see pictogram on the mounting bracket).

Without mounting bracket PSEN bracket:

Use two screws and nuts (Pilz recommends M4) to fasten the safety switch [6] to a suitable bracket.

5. Insert the respective PSEN cs4.1 Key [6] into the adapter [1].

Adjustment and testing

- ▶ The stated operating distances (see [Technical details](#)  28) only apply when the safety switch and actuator are installed facing each other in parallel. Operating distances may deviate if other arrangements are used.
- ▶ Note the maximum permitted lateral and vertical offset (see [Operating distances](#)  12] and [Lateral and vertical offset](#)  13).
- ▶ Always test the function with a connected evaluation device.



NOTICE

The safety functions should be checked after initial commissioning and each time the plant/machine is changed. The safety functions may only be checked by qualified personnel.

Operation



NOTICE

The safety functions should be checked after initial commissioning and each time the plant/machine is changed. The safety functions may only be checked by qualified personnel.

Status indicators:

- ▶ "Power/Fault" LED lights up green: The unit is ready for operation
- ▶ "Safety Gate" LED lights up yellow: Actuator is within the response range
- ▶ "Input" LED lights up yellow: There is a high signal at both inputs

Fault indicator:

- ▶ "Input" LED flashes yellow: the signal switches from high to low at one input, while a high signal remains on the other input (partial operation).
Remedy: Open both channels of the input circuit.
- ▶ "Power/Fault" LED lights up red: Error message
Remedy: Rectify fault and interrupt power supply.

Dimensions in mm

Safety switch PSEN cs3.1p

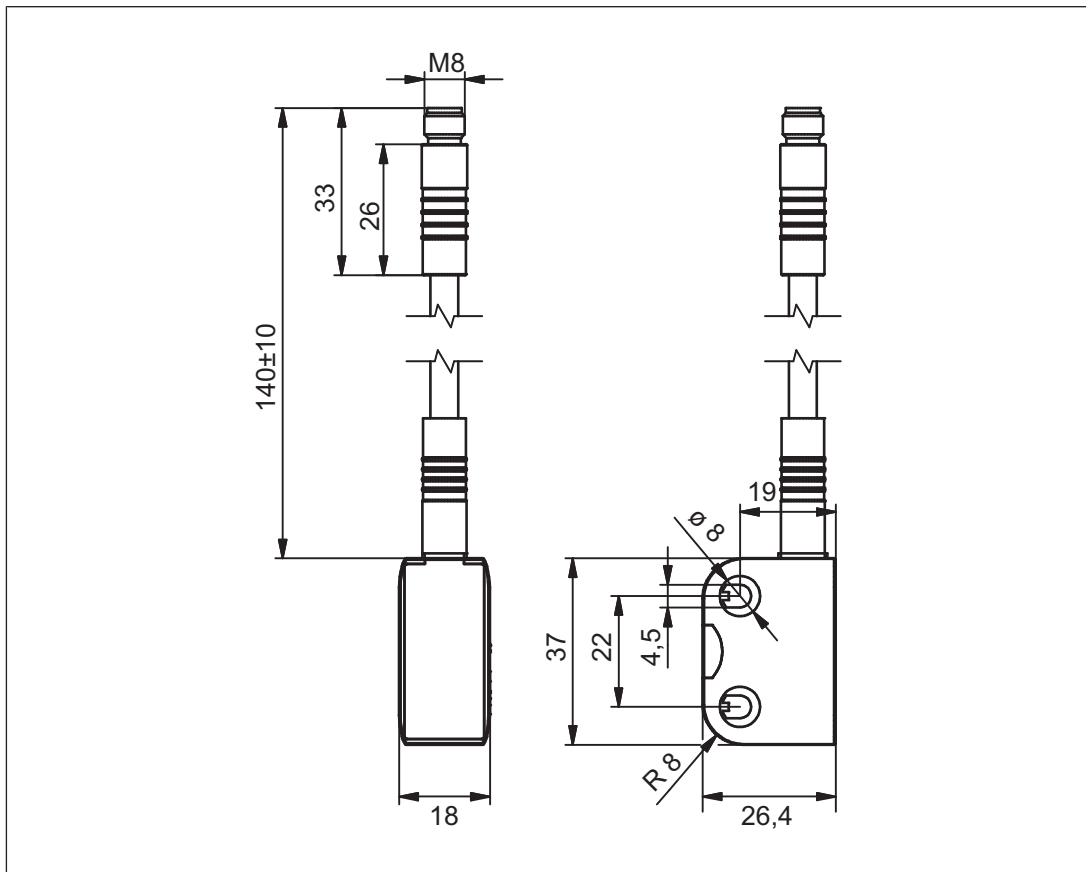

Actuator

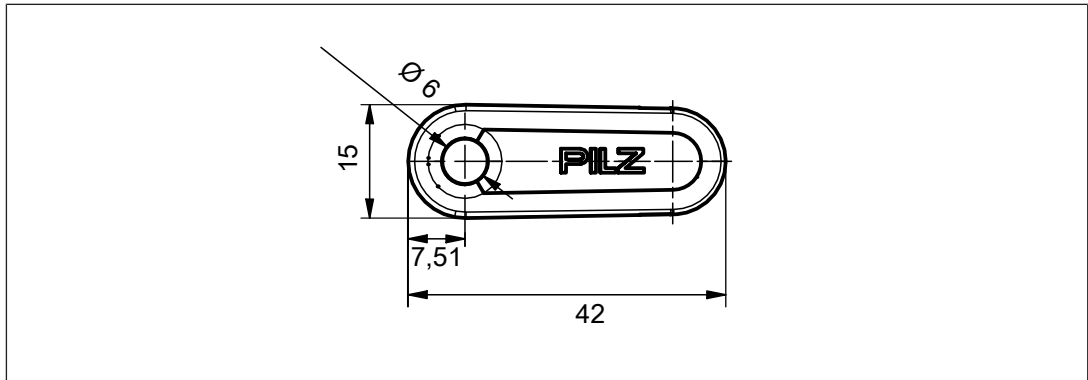

Adapter

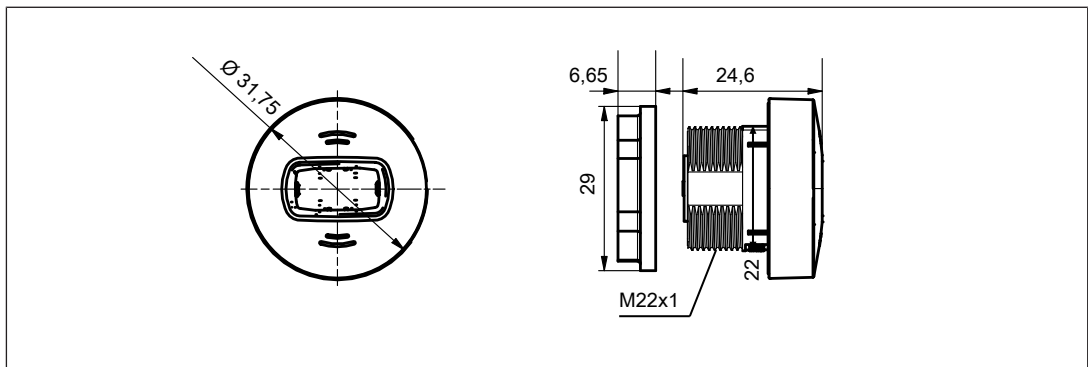

Mounting bracket

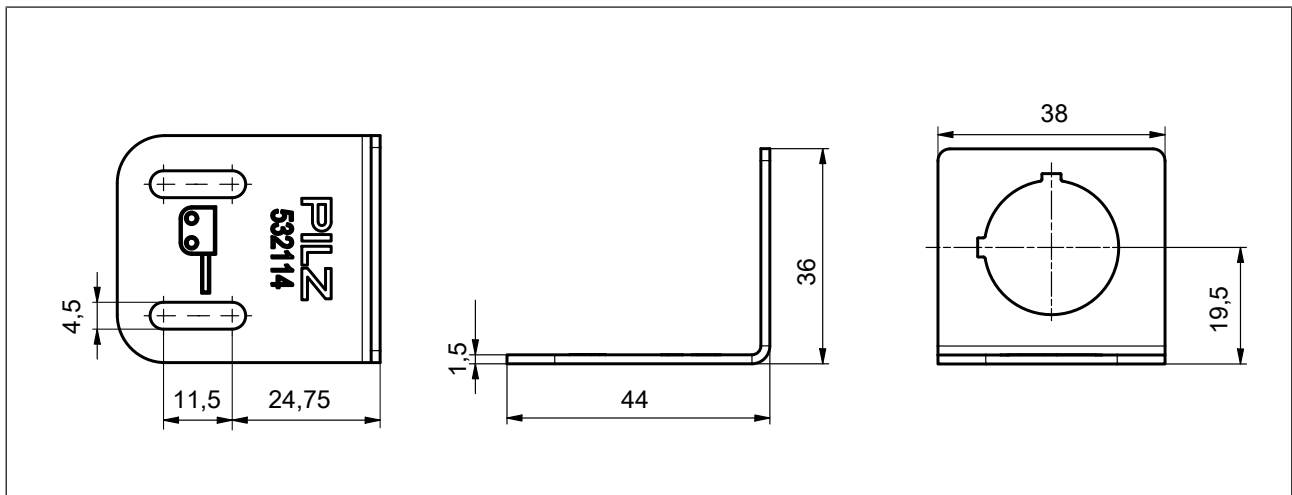

Spacer

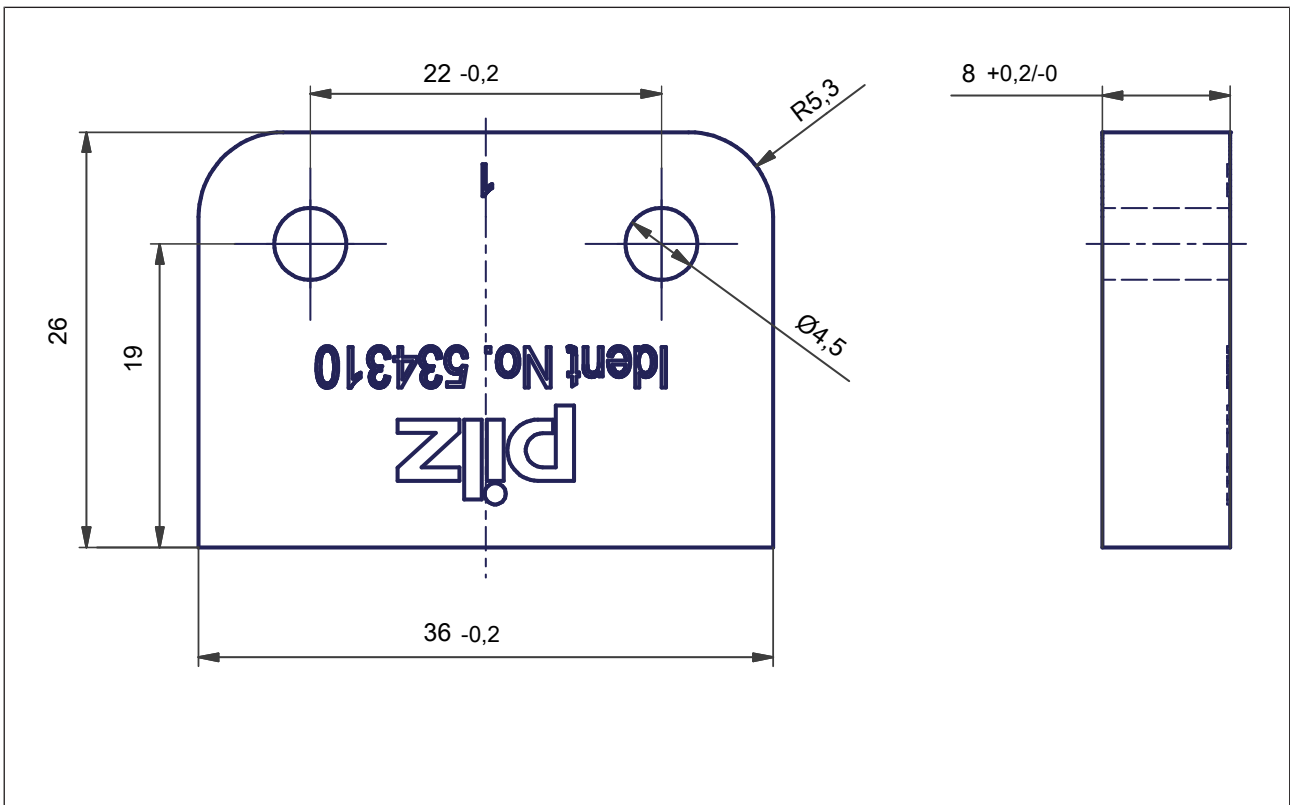

Technical details safety switch

Where standards are undated, the 2025-09 valid editions apply.

General	
Certifications	CE, EAC, FCC, IC, TÜV, UKCA, cULus Listed
Sensor's mode of operation	Transponders
Coding level in accordance with EN ISO 14119	Low
Design in accordance with EN ISO 14119	4
Classification in accordance with EN 60947-5-3	PDDB
Pilz coding type	coded
Transponders	
Frequency band	122 kHz - 128 kHz
Max. transmitter output	15 mW
Electrical data	
Supply voltage	
Voltage	24 V
Kind	DC
Voltage tolerance	-20 %/+20 %
Output of external power supply (DC)	1 W
Max. switching frequency	3 Hz
Max. cable capacitance at the safety outputs	
No-load, PNOZ with relay contacts	400 nF
PNOZmulti, PNOZelog, PSS	400 nF
Max. inrush current impulse	
Current pulse, A1	0,58 A
Pulse duration, A1	1 ms
No-load current	20 mA
Inputs	
Quantity	2
Voltage at inputs	24 V DC
Input current range	5 mA
Max. overall cable resistance R _{lmax}	
Single-channel at UB DC	1000 Ohm
Semiconductor outputs	
OSSD safety outputs	2
Signal outputs	1
Switching current per output	100 mA
Breaking capacity per output	2,4 W
Potential isolation from system voltage	No
Short circuit-proof	Yes
Residual current at outputs	20 µA
Voltage drop at OSSDs	0,7 V
Lowest operating current	2 mA

Semiconductor outputsUtilisation category in accordance with EN 60947-1 **DC-12****Times**Max. test pulse duration, safety outputs **450 µs**

Switch-on delay

after UB is applied **1 s**Inputs typ. **13 ms**Inputs max. **20 ms**Actuator typ. **60 ms**Actuator max. **150 ms**

Delay-on de-energisation

Inputs typ. **15 ms**Inputs max. **20 ms**Actuator typ. **40 ms**Actuator max. **260 ms**Risk time in accordance with EN 60947-5-3 **260 ms**Supply interruption before de-energisation **10 ms**Simultaneity, channel 1 and 2 max. **∞****Environmental data**

Ambient temperature

in accordance with the standard **EN 60068-2-14**Temperature range **-10 - 55 °C**

Storage temperature

in accordance with the standard **EN 60068-2-1/-2**Temperature range **-25 - 70 °C**

Climatic suitability

in accordance with the standard **EN 60068-2-78**Humidity **93 % r. h. at 40 °C**EMC **EN 60947-5-3**

Vibration

in accordance with the standard **EN 60947-5-2**Frequency **10 - 55 Hz**Amplitude **0,35 mm**

Shock stress

in accordance with the standard **EN 60947-5-2**Acceleration **30g**Duration **18 ms**

Airgap creepage

Overvoltage category **III**Pollution degree **3**Rated insulation voltage **60 V**Rated impulse withstand voltage **0,8 kV**

Protection type

Housing **IP6K9K**Connectors **IP67**

Operating distances

Actuator 1

Assured operating distance Sao	0,5 mm
Typical operating distance So	4 mm
Assured release distance Sar	30 mm
Typical release distance Sr	10 mm
Repetition accuracy switching distances	10 %
Typ. hysteresis	6 mm

Mechanical data

Min. bending radius (fixed permanently) K1	5 x Ø
Min. bending radius (moving) K1	10 x Ø
Cable diameter K1	5,55 mm
Min. distance between safety switches	100 mm
Sensor flush installation in accordance with EN 60947-5-2	yes, follow installation guidelines
Connection type	M8, 8-pin male connector
Cable	Li9Y11Y 8 x 0.14 mm²
Material	
Top	PBT
Max. fixing screws torque settings	0,8 Nm
Dimensions	
Height	37 mm
Width	26 mm
Depth	18 mm
Weight of safety switch	35 g
Weight	35 g

Technical details actuator

Order no. 541181 - 541183

See below for more order numbers

General	541181	541182	541183
Certifications	CE, EAC, FCC, IC, TÜV, UKCA, cULus Listed	CE, EAC, FCC, IC, TÜV, UKCA, cULus Listed	CE, EAC, FCC, IC, TÜV, UKCA, cULus Listed
Sensor's mode of operation	Transponders	Transponders	Transponders
Coding level in accordance with EN ISO 14119	High	High	High
Pilz coding type	fully coded	fully coded	fully coded
Transponders	541181	541182	541183
Frequency band	122 kHz - 128 kHz	122 kHz - 128 kHz	122 kHz - 128 kHz
Environmental data	541181	541182	541183
Ambient temperature in accordance with the standard	EN 60068-2-14	EN 60068-2-14	EN 60068-2-14
Temperature range	-10 - 55 °C	-10 - 55 °C	-10 - 55 °C
Storage temperature in accordance with the standard	EN 60068-2-1/-2	EN 60068-2-1/-2	EN 60068-2-1/-2
Temperature range	-25 - 70 °C	-25 - 70 °C	-25 - 70 °C
Climatic suitability in accordance with the standard	EN 60068-2-78	EN 60068-2-78	EN 60068-2-78
Humidity	93 % r. h. at 40 °C	93 % r. h. at 40 °C	93 % r. h. at 40 °C
EMC	EN 60947-5-3	EN 60947-5-3	EN 60947-5-3
Vibration in accordance with the standard	EN 60947-5-2	EN 60947-5-2	EN 60947-5-2
Frequency	10 - 55 Hz	10 - 55 Hz	10 - 55 Hz
Amplitude	0,35 mm	0,35 mm	0,35 mm
Shock stress in accordance with the standard	EN 60947-5-2	EN 60947-5-2	EN 60947-5-2
Acceleration	30g	30g	30g
Duration	18 ms	18 ms	18 ms
Protection type Housing	IP68	IP68	IP68
Mechanical data	541181	541182	541183
Material Top	PBT	PBT	PBT
Dimensions Height	15,1 mm	15,1 mm	15,1 mm
Width	42 mm	42 mm	42 mm
Depth	8 mm	8 mm	8 mm

Mechanical data	541181	541182	541183
Weight	5 g	5 g	5 g

Order no. 541184 - 541186

General	541184	541186
Certifications	CE, EAC, FCC, IC, TÜV, UKCA, cULus Listed	CE, EAC, FCC, IC, TÜV, UKCA, cULus Listed
Sensor's mode of operation	Transponders	Transponders
Coding level in accordance with EN ISO 14119	High	High
Pilz coding type	fully coded	fully coded
Transponders	541184	541186
Frequency band	122 kHz - 128 kHz	122 kHz - 128 kHz
Environmental data	541184	541186
Ambient temperature		
in accordance with the standard	EN 60068-2-14	EN 60068-2-14
Temperature range	-10 - 55 °C	-10 - 55 °C
Storage temperature		
in accordance with the standard	EN 60068-2-1/-2	EN 60068-2-1/-2
Temperature range	-25 - 70 °C	-25 - 70 °C
Climatic suitability		
in accordance with the standard	EN 60068-2-78	EN 60068-2-78
Humidity	93 % r. h. at 40 °C	93 % r. h. at 40 °C
EMC	EN 60947-5-3	EN 60947-5-3
Vibration		
in accordance with the standard	EN 60947-5-2	EN 60947-5-2
Frequency	10 - 55 Hz	10 - 55 Hz
Amplitude	0,35 mm	0,35 mm
Shock stress		
in accordance with the standard	EN 60947-5-2	EN 60947-5-2
Acceleration	30g	30g
Duration	18 ms	18 ms
Protection type		
Housing	IP68	IP68
Mechanical data	541184	541186
Material		
Top	PBT	PBT
Dimensions		
Height	15,1 mm	15,1 mm
Width	42 mm	42 mm
Depth	8 mm	8 mm
Weight	5 g	5 g

Classification in accordance with ZVEI, CB24I

The following tables describe the classes and specific values of the product interface and the classes of interfaces compatible with it. The classification is described in the ZVEI position paper "Classification of Binary 24 V Interfaces - Functional Safety aspects covered by dynamic testing".

Input

Interfaces

Drain

Class	C2
-------	----

Source

Class	C2, C3
-------	--------

Drain parameters

Max. test pulse duration	500 μ s
Min. test pulse interval	1,25 ms
Min. input resistance	6,6 Ohm
Max. capacitive load	18 pF

Single-pole output

Interfaces

Source

Interface	Sensor
Class	C2

Drain

Interface	Evaluation device
Class	C1, C2

Source parameters

Max. test pulse duration	450 μ s
Max. rated current	0,1 A
Max. capacitive load	0,4 μ F

Safety characteristic data



NOTICE

You must comply with the safety characteristic data in order to achieve the required safety level for your plant/machine.

Operating mode	EN ISO 13849-1: 2023	EN ISO 13849-1: 2023	EN IEC 62061 SIL CL/max.	EN IEC 62061 61508	EN/IEC 61511 61508	EN/IEC 61511 61508	EN ISO 13849-1: 2023
	PL	Category	SIL	PFH [1/h]	SIL	PFD	T _M [year]
2-ch. OSSD	PL e	Cat. 4	SIL CL 3	2,62E-09	–	7,68E-05	20

Explanatory notes for the safety-related characteristic data:

- ▶ T_M is the maximum mission time in accordance with EN ISO 13849-1. The value also applies as the retest interval in accordance with EN IEC 61508-6 and EN IEC 61511 and as the proof test interval and mission time in accordance with EN IEC 62061.

All the units used within a safety function must be considered when calculating the safety characteristic data.



INFORMATION

A safety function's SIL/PL values are **not** identical to the SIL/PL values of the products used and may differ from these.

Supplementary data

Radio approval

USA/Canada

FC FCC ID: VT8-PSENC33
IC: 7482A-PSENC33

FCC/IC-Requirements:

This product complies with Part 15 of the FCC Rules and with Industry Canada licence-exempt RSS standards.

Operation is subject to the following two conditions:

- 1) this product may not cause harmful interference, and
- 2) this product must accept any interference received, including interference that may cause undesired operation.

Changes or modifications made to this product not expressly approved by Pilz may void the FCC authorization to operate this equipment.

NOTE: This equipment has been tested and found to comply with the limits for a Class A digital device, pursuant to Part 15 of the FCC Rules. These limits are designed to provide reasonable protection against harmful interference when the equipment is operated in a commercial environment. This equipment generates, uses, and can radiate radio frequency energy and, if not installed and used in accordance with the instruction manual, may cause harmful interference to radio communications. Operation of this equipment in a residential area is likely to cause harmful interference in which case the user will be required to correct the interference at his own expense.

Le présent produit est conforme aux CNR d'Industrie Canada applicables aux appareils radio exempts de licence. L'exploitation est autorisée aux deux conditions suivantes:

- (1) le produit ne doit pas produire de brouillage, et
- (2) l'utilisateur de le produit doit accepter tout brouillage radioélectrique subi, même si le brouillage est susceptible d'en compromettre le fonctionnement.

Order reference

Safety switch

Product type	Features		Order no.
PSEN cs3.1p Key 1 switch	Safety switch, coded	8-pin M8 male connector	541065

Actuator

Product type	Features	Product ID
PSEN cs4.1 Key gy1	Transponder key for PSEN cs4.1 Key switch, marker 1 Colour: grey Material: plastic	541181
PSEN cs4.1 Key gy2	Transponder key for PSEN cs4.1 Key switch, marker 2 Colour: grey Material: plastic	541182
PSEN cs4.1 Key gy3	Transponder key for PSEN cs4.1 Key switch, marker 3 Colour: grey Material: plastic	541183
PSEN cs4.1 Key gy4	Transponder key for PSEN cs4.1 Key switch, marker 4 Colour: grey Material: plastic	541184
PSEN cs4.1 Key bl	Transponder key for PSEN cs4.1 Key switch, service marker Colour: blue Material: plastic	541186

Accessories

Installation material

Product type	Features	Product ID
PSEN cs key adapter V	Key adapter for PSEN cs key with nut	532113
PSEN cs key adapter bracket	Mounting device for PSEN cs key with spacer	532114
PSEN spacer (10 pcs.)	Spacer	534310

Cable

Product type	Connection 1	Connection 2	Length	Order no.
PSEN cable M12-8sf	straight, M12, 8-pin, socket	Open cable	3 m	540319
			5 m	540320
			10 m	540321
			20 m	540333
			30 m	540326
PSEN cable M12-8af	Angled, M12, 8-pin, socket	Open cable	3 m	540322
			5 m	540323
			10 m	540324
			30 m	540325
PSEN cable M12-8sf M12-8sm	straight, M12, 8-pin, socket	straight, M12, 8-pin, pin	2 m	540340
			5 m	540341
			10 m	540342
			20 m	540343
			30 m	540344
PSEN cable M8-8sf	Straight, M8, 8-pin, socket	Open cable	2 m	533150
			5 m	533151
			10 m	533152
PSEN cable M8-8af, 10m	Angled, M8, 8-pin, socket		10 m	533162
PSEN cable M8-8sf	Straight, M8, 8-pin, socket		20 m	533153
			30 m	533154
PSEN cable M8-8sf M8-sm	Straight, M8, 8-pin, pin	Straight, M8, 8-pin, socket	0.5 m	533155
PSEN cable M8-8sf M8-8sm			1 m	533156
PSEN cable M8-8sf M8-8sm			2 m	533157

Adapter

Product type	Features	Connector X1	Connector X2	Connector X3	Order no.
PSEN converter M8-8sf -- M12-8sm	0.25 m	M12, 8-pin female con- nector, straight	M 8, 8-pin fe- male con- nector, straight		540329

Series connection

Product type	Connection X1	Connection X2	Connection X3	Order no.
PSEN Y junction M12 SENSOR	M12, 8-pin, pin	M12, 8-pin, socket	M12, 8-pin, socket	540315
PSEN Y junction M12 cable channel	M12, 8-pin, pin	M12, 8-pin, socket	M12, 8-pin, socket	540316
PSEN T junction M12	M12, 8-pin, socket	M12, 8-pin, pin	M8, 4-pin, pin	540331
PSEN Y junction M8-M12/M12 PIGTAIL	M12, 8-pin, socket	M12, 8-pin, pin	M8, 8-pin, socket	540337
PSEN Y junction M12-M12/M12 PIGTAIL	M12, 8-pin, socket	M12, 8-pin, pin	M12, 8-pin, socket	540338
PDP67 F 4 code	Decentralised passive junction			773603
PDP67 F 4 code VA	Decentralised passive junction, V2A ring nut			773613

Safety Device Diagnostics

Product type	Features	Connection type	Order no.
PSEN ix2 F4 code	Interface for connecting max. 4 PSEN safety sensors	Spring-loaded terminal	535111
PSEN ix2 F8 code	Interface for connecting max. 8 PSEN safety sensors	Spring-loaded terminal	535112
SDD ES ETH	Modbus/TCP fieldbus module for Safety Device Diagnostics	Spring-loaded terminal	540130
SDD ES Profibus	Profibus fieldbus module for Safety Device Diagnostics	Spring-loaded terminal	540132
SDD ES Profinet	Profinet fieldbus module for Safety Device Diagnostics	Spring-loaded terminal	540138

EC declaration of conformity

This product/these products meet(s) the requirements of the following directives of the European Parliament and of the Council.

- ▶ 2006/42/EC on machines
- ▶ 2014/53/EU on radio equipment

The complete EC Declaration of Conformity is available on the Internet at www.pilz.com/downloads.

Representative: Pilz GmbH & Co. KG, Felix-Wankel-Str. 2, 73760 Ostfildern, Germany

UKCA-Declaration of Conformity

This product(s) complies with following UK legislation:

- ▶ Supply of Machinery (Safety) Regulations 2008
- ▶ Radio Equipment Regulations 2017

The complete UKCA Declaration of Conformity is available on the Internet at www.pilz.com/downloads.

Representative: Pilz Automation Technology, Pilz House, Little Colliers Field, Corby, Northamptonshire, NN18 8TJ United Kingdom, eMail: mail@pilz.co.uk

Support

Technical support is available from Pilz round the clock.

Americas

Brazil

+55 11 97569-2804

Canada

+1 888 315 7459

Mexico

+52 55 5572 1300

USA (toll-free)

+1 877-PILZUSA (745-9872)

Asia

China

+86 400-088-3566

Japan

+81 45 471-2281

South Korea

+82 31 778 3390

Australia and Oceania

Australia

+61 3 95600621

New Zealand

+64 9 6345350

Europe

Austria

+43 1 7986263-444

Belgium, Luxembourg

+32 9 3217570

France

+33 3 88104003

Germany

+49 711 3409-444

Ireland

+353 21 4804983

Italy, Malta

+39 0362 1826711

Scandinavia

+45 74436332

Spain

+34 938497433

Switzerland

+41 62 88979-32

The Netherlands

+31 347 320477

Türkiye

+90 216 5775552

United Kingdom

+44 1536 460866

You can reach our international hotline on:

+49 711 3409-222

support@pilz.com

Pilz develops environmentally-friendly products using ecological materials and energy-saving technologies. Offices and production facilities are ecologically designed, environmentally-aware and energy-saving. So Pilz offers sustainability, plus the security of using energy-efficient products and environmentally-friendly solutions.



We are represented internationally. Please refer to our homepage www.pilz.com for further details or contact our headquarters.

Headquarters: Pilz GmbH & Co. KG, Felix-Wankel-Straße 2, 73760 Ostfildern, Germany
Telephone: +49 711 3409-0, E-Mail: info@pilz.com, Internet: www.pilz.com

PILZ
THE SPIRIT OF SAFETY

CECE, CHRE, CMSE®, INDUSTRIAL Pi®, Leansafe®, Myze®, PAS4000®, PAScal®, PASconfig®, Pilz®, PIT®, PMCPirimo®, PMCProtego®, PMCTiendo®, PMD®, PMi®, PNOZ®, Primo®, PSEN®, PSS®, PVIS®, SafetyBUS p®, SafetyNET p®, THE SPIRIT OF SAFETY® are registered and protected trademarks of Pilz GmbH & Co. KG in some countries. We would point out that product features may vary from the details stated in this document, depending on the status at the time of publication and the scope of the equipment. We accept no responsibility for the validity, accuracy and entirety of the text and graphics presented in this information. Please contact our Technical Support if you have any questions.

1005448-EN-04, 2025-12 Printed in Germany
© Pilz GmbH & Co. KG, 2024