



► PSEN cs2.13p ATEX

PILZ
THE SPIRIT OF SAFETY

Operating Manual-21133-EN-22
- PSEN sensor technology



This document is the original document.

Where unavoidable, for reasons of readability, the masculine form has been selected when formulating this document. We do assure you that all persons are regarded without discrimination and on an equal basis.

All rights to this documentation are reserved by Pilz GmbH & Co. KG. Copies may be made for the user's internal purposes. Suggestions and comments for improving this documentation will be gratefully received.

CECE®, CHRE®, CMSE®, INDUSTRIAL PI®, Leansafe®, MYZEL®, PAS4000®, PAS-cal®, PASconfig®, Pilz®, PIT®, PMCprimo®, PMCprotego®, PM Ctendo®, PMD®, PMI®, PNOZ®, Primo®, PSEN®, PSS®, PVIS®, SafetyBUS p®, SafetyEYE®, SafetyNET p®, THE SPIRIT OF SAFETY® are registered and protected trademarks of Pilz GmbH & Co. KG in some countries.



SD means Secure Digital

Introduction	5
Validity of documentation	5
Using the documentation	5
Definition of symbols	5
Safety	6
Intended use	6
Safety regulations	7
Safety assessment	7
Additional documents that apply	7
Use of qualified personnel	7
Warranty and liability	8
Disposal	8
For your safety	8
Unit features	9
Function description	10
Safety Device Diagnostics	11
Operating distances	12
Lateral and vertical offset	13
Wiring	13
Terminal assignment connectors	15

Connection to evaluation devices	16
Teaching in the actuator	22
Installation	23
Periodic test	25
Adjustment	25
ATEX installation and operating regulations (X)	25
Operation	27
Dimensions in mm	27
Technical details safety switch	28
Technical details actuator	30
Classification in accordance with ZVEI, CB24I	31
Safety characteristic data	32
Supplementary data	33
Radio approval	33
Order reference	34
Safety switch	34
Actuator	34
Complete systems	34
Accessories	34
EC declaration of conformity	37
UKCA-Declaration of Conformity	37

Introduction

Validity of documentation

This documentation is valid for the product PSEN cs2.13p from Version 2.0.

This operating manual explains the function and operation, describes the installation and provides guidelines on how to connect the product.

Using the documentation

This document is intended for instruction. Only install and commission the product if you have read and understood this document. The document should be retained for future reference.

Definition of symbols

Information that is particularly important is identified as follows:



DANGER!

This warning must be heeded! It warns of a hazardous situation that poses an immediate threat of serious injury and death and indicates preventive measures that can be taken.



WARNING!

This warning must be heeded! It warns of a hazardous situation that could lead to serious injury and death and indicates preventive measures that can be taken.



CAUTION!

This refers to a hazard that can lead to a less serious or minor injury plus material damage, and also provides information on preventive measures that can be taken.



NOTICE

This describes a situation in which the product or devices could be damaged and also provides information on preventive measures that can be taken. It also highlights areas within the text that are of particular importance.



INFORMATION

This gives advice on applications and provides information on special features.

Safety

Intended use

The safety switch is approved for use in potentially explosive atmospheres in accordance with EN 60079-0, EN 60079-7, EN 60079-18, EN 60079-31.

Ex area Group II, Category 3G, Zone 2 (Gas): II 3G Ex ec mc IIC 90°C(T5) Gc and Category 3D, Zone 22 (dust): II 3D Ex mc tc IIIC T90°C Dc.

The safety functions of the safety switch are:

- ▶ Safe shutdown of safety outputs when the actuator is removed beyond the assured release distance s_{ar} or when the actuator is not detected
- ▶ Remain shut down safely after the actuator has been removed

The safety switch meets the requirements in accordance with:

- ▶ EN IEC 60947-5-3: PDDb with the actuator PSEN cs2.1
- ▶ EN IEC 62061: SIL CL 3
- ▶ EN ISO 13849-1: PL e (Cat. 4)
- ▶ EN ISO 14119: Coding level High, design 4

The safety switch may only be used with the corresponding actuator PSEN cs2.1.

The safety level PL e (Cat. 4)/SIL CL 3 is achieved only when:

- ▶ the safety outputs use 2-channel processing.

The actuator PSEN cs2.1 may **not** be used in environments with high electromagnetic fields with effective values > 1 A/m or 3 V/m (e.g. high power electrolysis plants).

Improper use

The following is deemed improper use in particular:

- ▶ Any component, technical or electrical modification to the product,
- ▶ Use of the product outside the areas described in this operating manual,
- ▶ Use of the product outside the technical details (see chapter entitled [Technical Details](#) [ 28]).

**NOTICE****EMC-compliant electrical installation**

The product is designed for use in an industrial environment. The product may cause interference if installed in other environments. If installed in other environments, measures should be taken to comply with the applicable standards and directives for the respective installation site with regard to interference.

Safety regulations**Safety assessment**

Before using a unit, a risk assessment is required in accordance with the Machinery Regulation.

Connecting additional units may result in further risks. Take the necessary measures to protect against corruption.

The product as an individual component fulfils the functional safety requirements in accordance with EN ISO 13849 and EN IEC 62061. However, this does not guarantee the functional safety of the overall plant/machine. To achieve the relevant safety level of the overall plant/machine's required safety functions, each safety function needs to be considered separately.

Additional documents that apply

Please read and take note of the following documents.

Only for use of the Safety Device Diagnostics (SDD):

- ▶ Fieldbus module operating manual, SDD ES PROFINET (1003826) for example
- ▶ System description Safety Device Diagnostics (1003827)

For the use of passive junctions:

- ▶ Operating manual of a passive junction, for example:
 - PSEN ix2 F4 code
 - PSEN ix2 F8 code
 - PDP67 F 4 code
 - PSEN Y junction

You will need to be conversant with the information in these documents in order to fully understand this operating manual.

Use of qualified personnel

The products may only be assembled, installed, programmed, commissioned, operated, de-commissioned and maintained by persons who are competent to do so.

A competent person is a qualified and knowledgeable person who, because of their training, experience and current professional activity, has the specialist knowledge required. In order to inspect, assess and handle products, devices, systems, plant and machinery, this person must be familiar with the state of the art and the applicable national, European and international laws, directives and standards.

It is the company's responsibility only to employ personnel who

- ▶ Are familiar with the basic regulations concerning health and safety / accident prevention,
- ▶ Have read and understood the information provided in the section entitled Safety
- ▶ Have a good knowledge of the generic and specialist standards applicable to the specific application.

Warranty and liability

All claims to warranty and liability will be rendered invalid if

- ▶ The product was used contrary to the purpose for which it is intended,
- ▶ Damage can be attributed to not having followed the guidelines in the manual,
- ▶ Operating personnel are not suitably qualified,
- ▶ Any type of modification has been made (e.g. exchanging components on the PCB boards, soldering work etc.).

Disposal

- ▶ In safety-related applications, please comply with the mission time T_M stated in the safety-related characteristic data.
- ▶ When decommissioning, please comply with local regulations regarding the disposal of electronic devices (e.g. Electrical and Electronic Equipment Act).

For your safety



WARNING!

Loss of safety function due to manipulation of the interlocking device

Manipulation of the interlocking device may lead to serious injury and death.

- You should prevent any possibility of the interlocking device being manipulated through the use of a spare actuator.
- Keep the substitute actuator in a safe place and protect it from unauthorised access.
- If substitute actuators are used, these must be installed as described under [Installation](#) [ 23].
- If the original actuators are replaced with substitute actuators, the original actuators must be destroyed before disposal.

**WARNING!**

Ignition spark from cable separator/connector within the potentially explosive area can trigger an explosion!

When the cable separators/connectors are used within the potentially explosive area, sparks can be caused and lead to an explosion.

- Make sure that the cable separators/connectors are used only outside the potentially explosive area.

- ▶ Do not remove the connector's protective cap until you are just about to connect the product. This will prevent potential contamination.
- ▶ Switch off the supply voltage before disconnecting the plug-in connection.
- ▶ Make sure that when connecting or separating the connector the pollution degree 1 or 2 is maintained.
- ▶ The connector should be protected from accidental loosening (e.g. using a cable tie).
- ▶ The IP protection type (see [Technical details \[📖 28\]](#)) has been determined in accordance with DIN EN 60529 with a safety switch that is as new.

Unit features

- ▶ Transponder technology for presence detection
- ▶ Pilz coding type: fully coded
- ▶ Dual-channel operation
- ▶ 2 safety inputs for series connection of multiple safety switches
- ▶ 2 safety outputs
- ▶ Safety Device Diagnostics (SDD)
 - Safety Device Diagnostics can be used to retrieve sensor information on one or more sensors, to perform actions and to read and write configuration parameters.
 - Manipulation protection in accordance with ISO 14119 is possible by verifying the short name of the actuator through the controller via SDD communication
- ▶ Diagnostic input for Y1 for Safety Device Diagnostics (SDD)
- ▶ Signal output/diagnostic output Y32 for Safety Device Diagnostics
- ▶ LED display for:
 - State of the actuator
 - State of the inputs
 - Supply voltage/fault
- ▶ 4 directions of actuation

Function description

The safety outputs may have a high or low signal, depending on the position of the actuator and the signal status of the inputs.

In a safe condition the safety outputs are in the OFF state.

Electrical states of the inputs and outputs (when safety switch is ready for operation: Power/Fault LED is green):

Actuator within the response range	Safety input S11	Safety input S21	Safety output 12	Safety output 22	Signal output Y32 (without use of the SDD)
Yes	High	High	High	High	High
Yes	Low	Low	Low	Low	High
No	x	x	Low	Low	Low
Yes	High	Low	High	Low	High
Yes	Low	High	Low	High	High

x: High or low signal

Plausibility monitoring for safety inputs S11 and S21

- ▶ If one safety input switches from high to low, while the other safety input remains high, an unequal status is displayed: **Input LED flashes yellow**
- ▶ If this safety input switches back from low to high, while the other safety input remains high, a plausibility error is displayed and a partial operation lock is triggered: **Input LED flashes yellow**

A switch to a high signal will only lead to normal safety switch operation if both inputs had a low signal. From this moment on, the switch to high may occur (partial operation lock see [Error display \[27\]](#)).

▶ Diagnostic input Y1

If an SDD fieldbus module is used, the diagnostic input Y1 is automatically activated and data is read.

If no SDD fieldbus module is used, the diagnostic input Y1 is not used.

▶ Signal output/diagnostic output Y32 in SDD mode

If an SDD fieldbus module is used, the signal output/diagnostic output Y32 is activated for writing data.

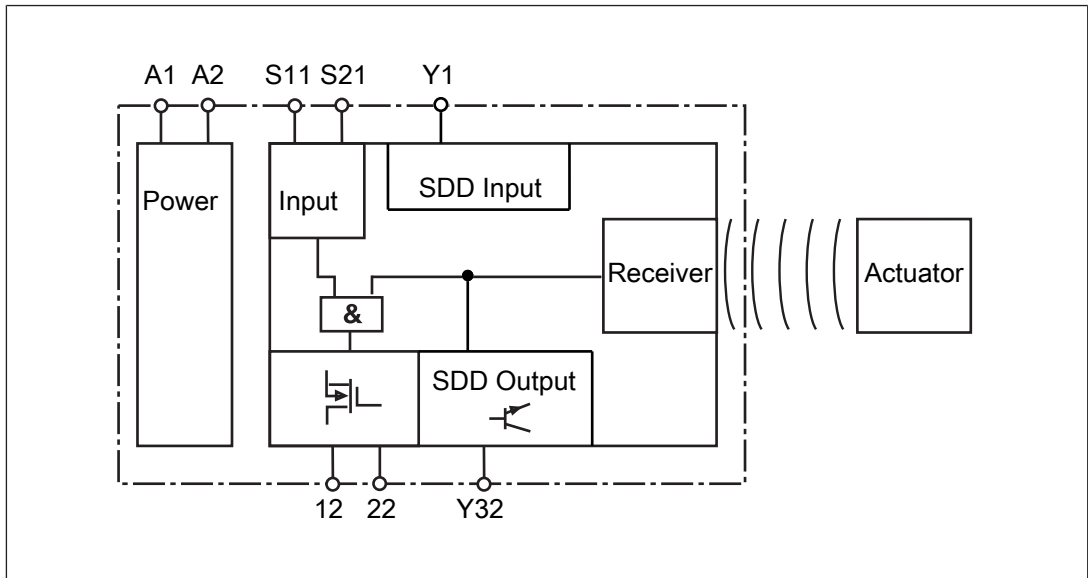

Safety Device Diagnostics

Safety Device Diagnostics is an option that can be selected independently of the safety-related wiring.

When using the Safety Device Diagnostics, up to 16 sensors connected in series can be connected as a subscriber to a fieldbus module.

The communication of the sensors with the fieldbus module is automatically built up again with each new supply of the supply voltage. As a result, a sensor can be exchanged, e.g. when servicing, without the need for special measures.

Any exchange can be detected via the fieldbus module, through the serial number for example.

- ▶ With Safety Device Diagnostics there are the following diagnostic options for the fieldbus module:
 - Poll information of the sensors (examples: what sensor in the series has switched, at what point could there be an open circuit in the series connection)
 - Read configuration parameters of the sensor (examples: Number of teach-in processes remaining, serial number of the sensor)
 - Perform actions (example: poll updated actuator name)

The results of the sensor diagnostics can be checked already during the installation phase via the display in the fieldbus module, without the need to connect the fieldbus module to the network.

- ▶ With Safety Device Diagnostics there are the following diagnostic options for the fieldbus module for simple wiring:
 - Information is passed on via the fieldbus module directly to the network
 - Mappings of the signal outputs to the sensor are automated by the SDD.

This prevents wiring errors and an expansion or reduction of the sensors is possible without the need to change existing wiring.

- Wiring in accordance with IP20: Rapid installation in the control cabinet is enabled.
- Wiring in accordance with IP67: Various passive junctions can be used (see [Order references for accessories](#) [34]) to connect several sensors with only one cable from the field in the control cabinet.

Further information on Safety Device Diagnostics can be found in [Additional documents that apply](#) [7].

Operating distances

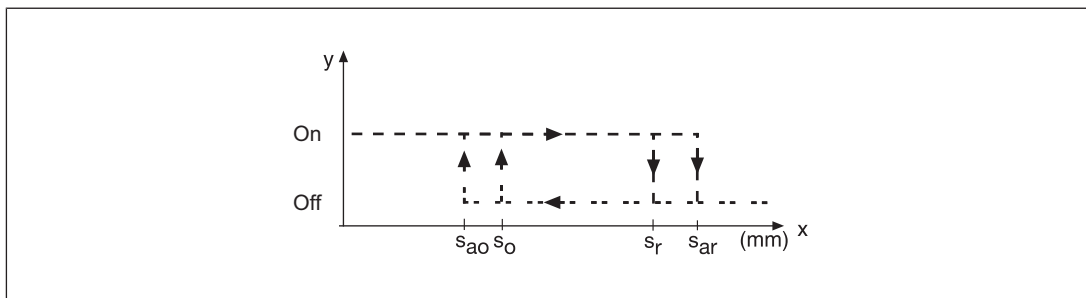

Legend:

- ▶ S_{ao} : Assured operating distance: 15 mm
- ▶ S_o : Typical operating distance: 21 mm
- ▶ S_r : Typical release distance: 32 mm
- ▶ S_{ar} : Assured release distance: 40 mm

Lateral and vertical offset

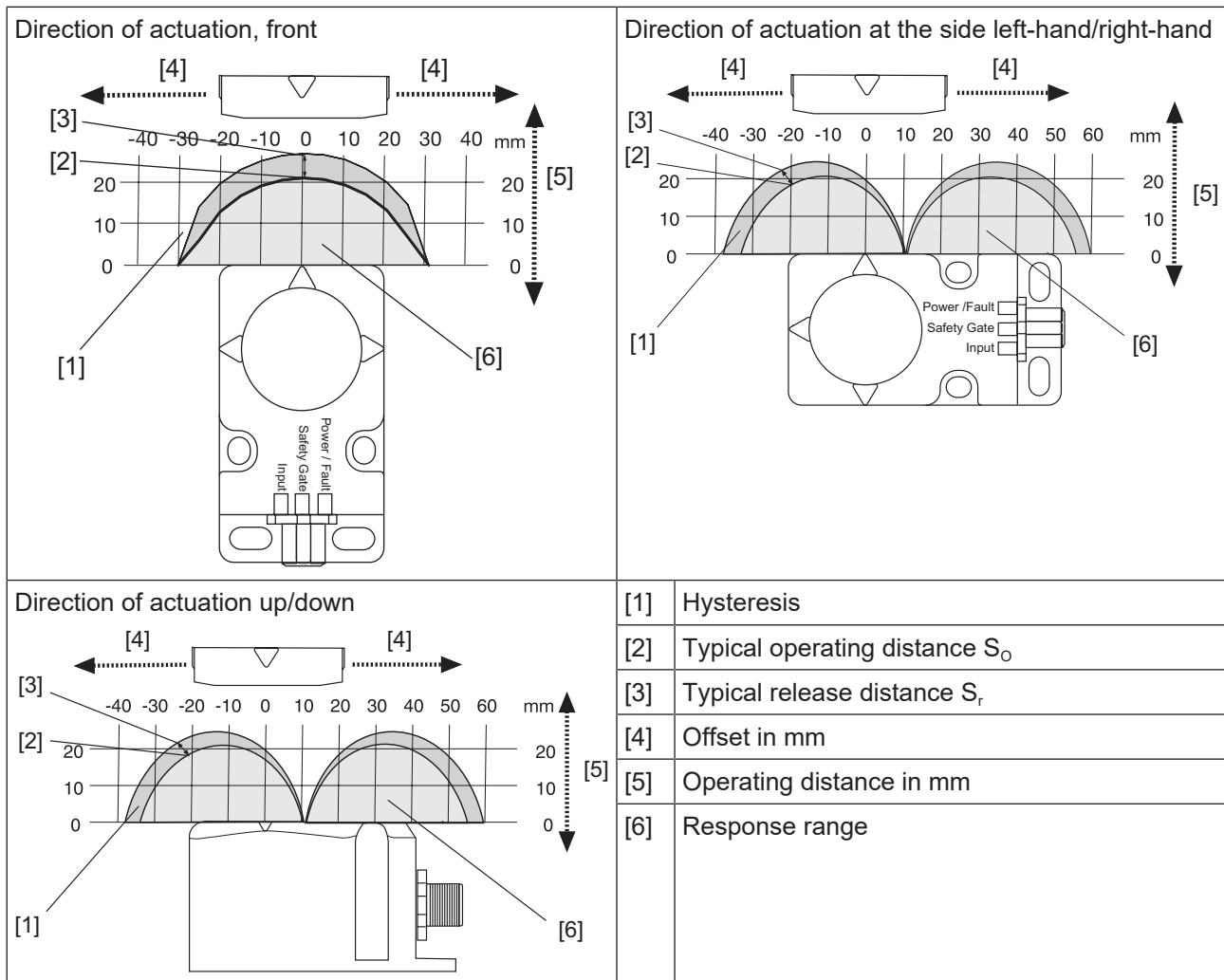

Wiring

Please note:

- ▶ Information given in the [Technical details \[28\]](#) must be followed.
- ▶ The max. cable length l_{max} in the input circuit is calculated from
 - the max. cable capacitance at the safety outputs (see [Technical data \[28\]](#)).
 - the minimum permitted supply voltage at the safety switch (19.2 V).
- ▶ When the safety inputs of the safety switch are controlled by an upstream device, and they are not wired with 24 V,
 - They must be monitored for shorts across contacts (e.g. by PSEN cs, PSEN ml, PSEN sg or PSEN sl) **or**
 - The faults at the safety inputs that can occur by shorts across contact will have to be excluded by suitable measures (e.g. wiring in accordance with EN 602041).
- ▶ The power supply must meet the regulations for extra low voltages with protective electrical separation (SELV, PELV).
- ▶ The inputs and outputs of the safety switch must have protective separation from voltages over 60 VDC.



INFORMATION

Only use safety relays with a 24 VDC supply voltage. Safety relays with a wide-range power supply or in AC device versions have internal potential isolation and are not suitable as evaluation devices.

- ▶ The supply voltage to the safety switch must be protected with a 2 A to 4 A quick-acting fuse.
- ▶ Ensure the wiring and EMC requirements of EN 60204-1 are met.
- ▶ When connecting in series, consider the requirements of manipulation protection and the protection against bypassing or from overriding the safety switch (EN ISO 14119).
- ▶ Ensure that the connector of the safety switch in the EX area is not removed or inserted.
- ▶ Any metallic parts (also accessories) must be connected to the equipotential bonding in case of a risk of charging.
- ▶ Note the requirements in accordance with EN 60079-0 and EN 60079-14.
- ▶ The protection type must not be adversely affected by the plug-in connector.
- ▶ The plug-in connection may only be removed using a tool.

This can be achieved using these solutions, for example:

- by design, using shielding plates or
- by using clips for manipulation protection (item no. C1000079 or C1000080).
- ▶ Check the compatibility of the mechanical dimension of clip and round plug-in connector.
- ▶ As shown in the diagram, join the clips over the cable screw connection and press both parts firmly together. The clips must audibly lock into position and they must not be manually detachable.

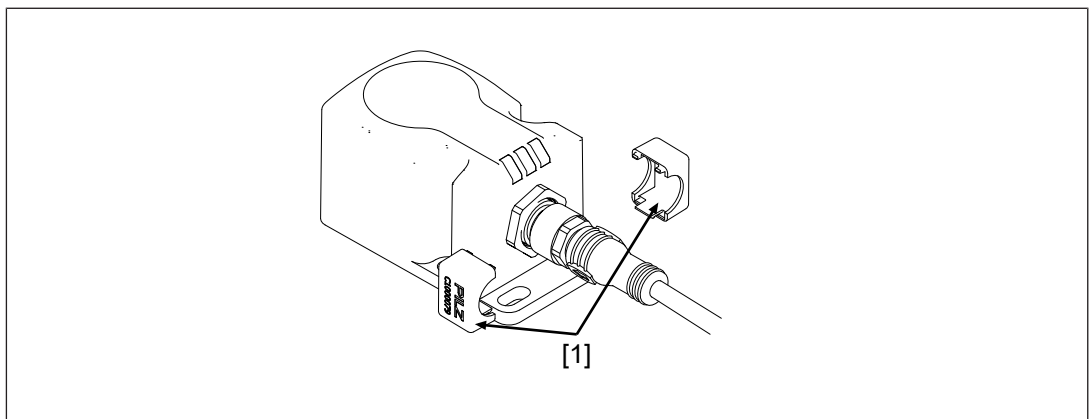

Legend

[1] Manipulation protection CABLE/M12/CLIP

Terminal assignment connectors

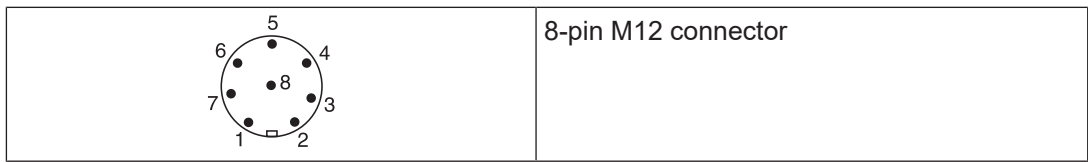

PIN	Connection designation	Function	Wire colour
1	S21	Input, channel 2	white
2	A1	+24 VUB	brown
3	12	Output, channel1	green
4	22	Output, channel2	yellow
5	Y32	Signal output/diagnostic output	grey
6	S11	Input, channel 1	pink
7	A2	0 V UB	blue
8	Y1	Diagnostics input	red

The wire colour also applies for the cable available from Pilz as an accessory.

Connection to evaluation devices

Make sure that the selected evaluation device has the following property:

- ▶ OSSD signals are evaluated through 2 channels with plausibility monitoring

Note:

- ▶ The use of Safety Device Diagnostics is described in detail in the Safety Device Diagnostics System Description (1003827).



CAUTION!

Do not connect the signal output to 0 V!

If the signal output Y32 is connected to 0 V, the safety switch may be damaged as a result. Connect the signal output Y32 to a consumer, e.g. to the input on a control system, or leave the signal output unconnected. Also note the max. current (see [Technical details \[28\]](#)).

Connection diagram, single connection without SDD

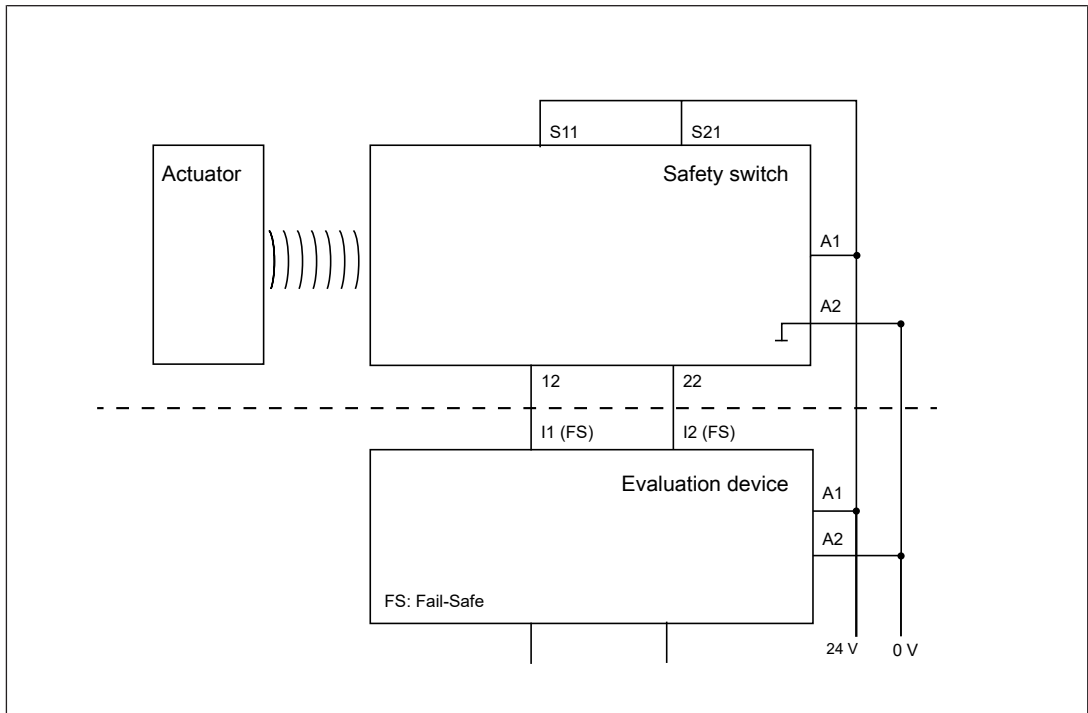

Connection diagram, single connection with SDD

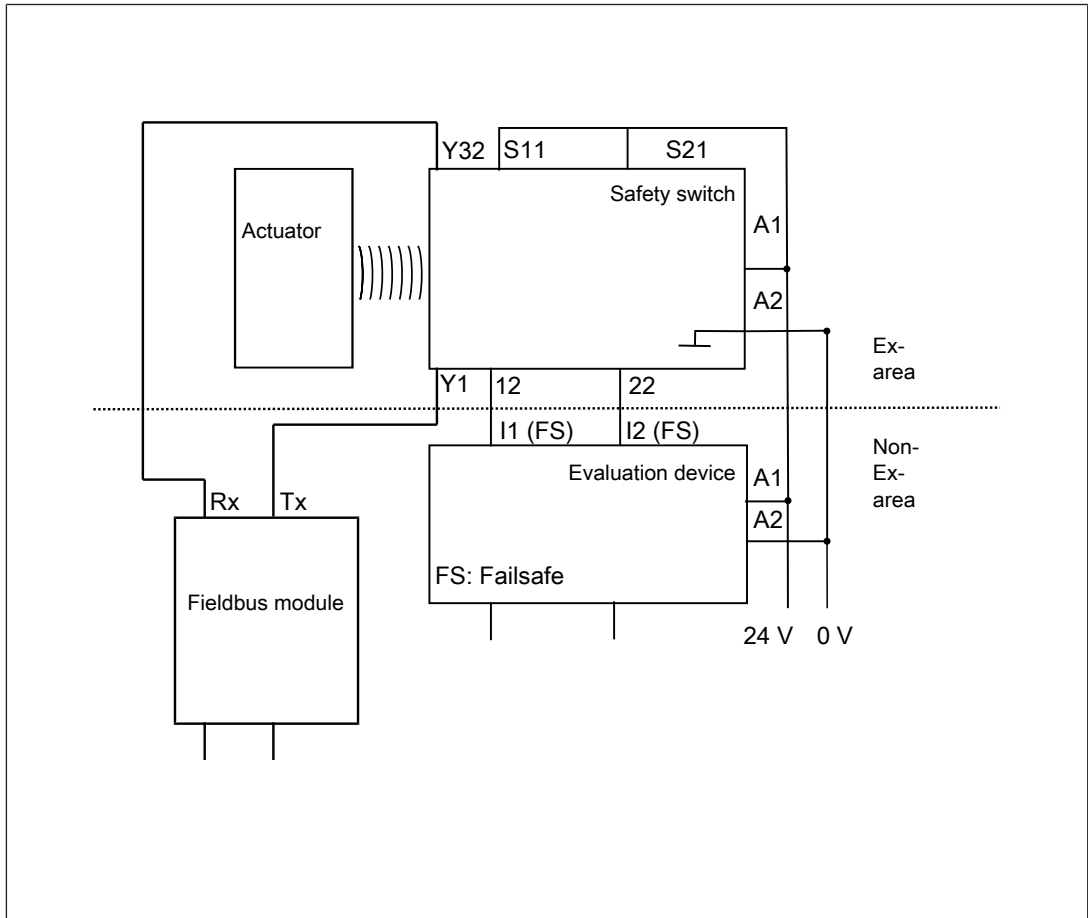

Series connection

The safety sensors PSENcode are also suitable for series connection with other sensors.

Maximum number of PSENcode sensors in series connections for SIL CL 3

- ▶ PSENcode large design (PSEN cs1.xp - cs2.xp): 8

If other sensors are used, the number must be recalculated.

In practice, the maximum possible number will be limited by the following parameters, among others:

- ▶ The required SIL level (e.g. SIL CL 3),
- ▶ the required performance level (e.g. PL e (Cat. 4)),
- ▶ the maximum delay or risk time permitted by the application.

Ensure there is sufficient supply voltage, taking inrush currents and fusing into consideration.

**CAUTION!****Extension of delay-on de-energisation**

When several (n) devices are connected in series, the delay-on de-energisation time adds with the number of interconnected safety switches.

The max. delay-on de-energisation is made up of the risk time (see [Technical details](#) [ 28])

+ (n-1) x max. delay-on de-energisation of the inputs

+ max. delay-on de-energisation of the evaluation device

- ▶ When making series connections using SDD, only use the following passive junctions.

- PSEN ix2 F4 code
- PSEN ix2 F8 code
- PSEN Y junction M8-M12/M12 PIGTAIL
- PSEN Y junction M12-M12/M12 PIGTAIL
- PSEN Y junction M12 SENSOR
- PSEN Y junction M12 cable channel

Function test when safety channels are connected in series

Before commissioning and after each change, check that the safety function is guaranteed when the gates are opened. To do this, open each gate individually and check the status at the inputs on the evaluation device:

- ▶ Close all the gates.

There must be high signals at the inputs on the evaluation device (e.g. S11, S21 or I1, I2).

- ▶ Open one gate; the other gates remain closed.

There must be low signals at the inputs on the evaluation device (e.g. S11, S21 or I1, I2).

- ▶ Close the gate again.

High signals must return at the inputs on the evaluation device (e.g. S11, S21 or I1, I2).

- ▶ Repeat the test for each gate.

- ▶ If the input signals do not react as described above, check and rectify the wiring and carry out the test again.

Connection diagram, series connection without SDD

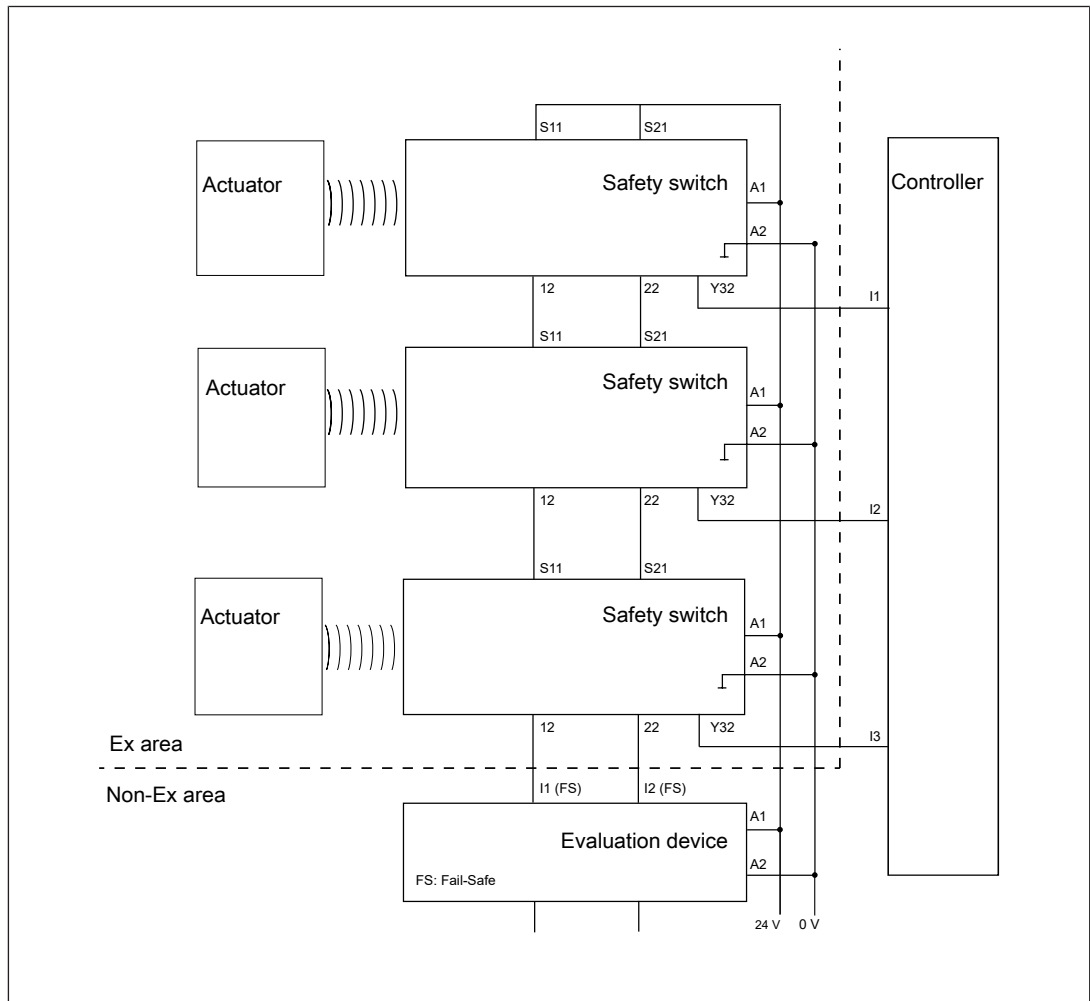

Connection diagram, series connection with SDD

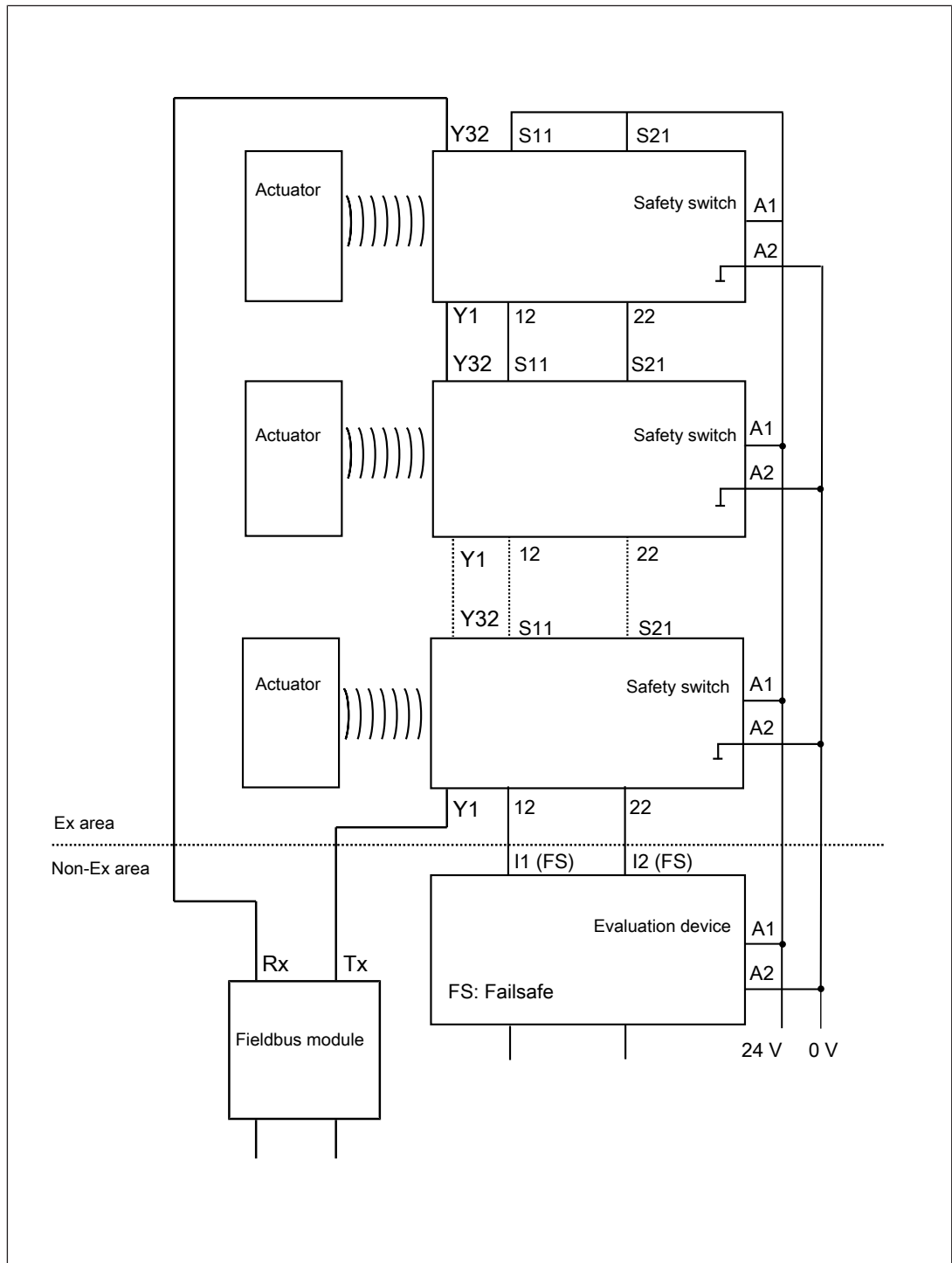

Connection to Pilz evaluation devices

The safety switch PSEN cs2.13p can be connected to Pilz evaluation devices, for example.

Suitable Pilz evaluation devices are, for example:

- ▶ PNOZelog for safety gate monitoring
- ▶ PNOZpower for safety gate monitoring
- ▶ PNOZsigma for safety gate monitoring
- ▶ PNOZ X for safety gate monitoring
- ▶ PNOZmulti for safety gate monitoring
Configure the safety switch in the PNOZmulti Configurator with switch type 3.
- ▶ PSS for safety gate monitoring with standard function block SB064, SB066 or FS_Safety Gate

The correct connection to the respective evaluation device is described in the operating manual for the evaluation device. Make sure that the connection is made in accordance with the specifications in the operating manual for the selected evaluation device.

The connections to two evaluation devices are shown on the following pages, by way of example:

- ▶ PNOZ s3 and
- ▶ PNOZmulti

PNOZ s3

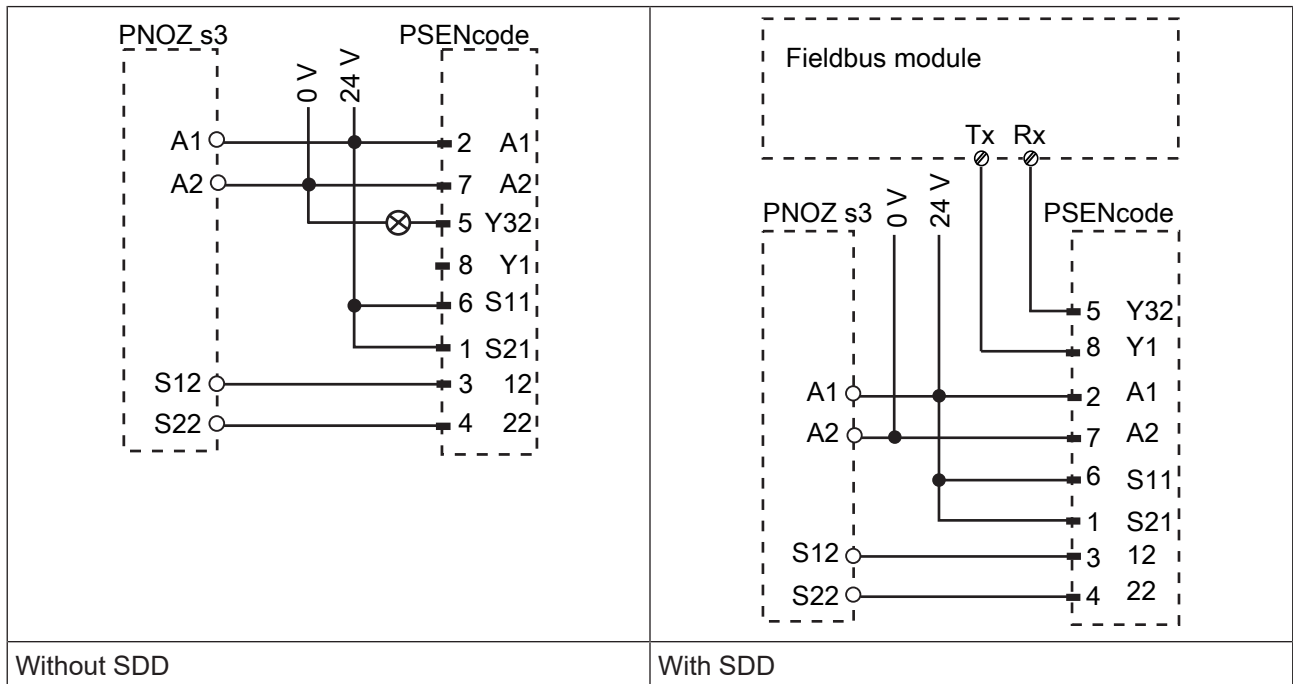

PNOZmulti

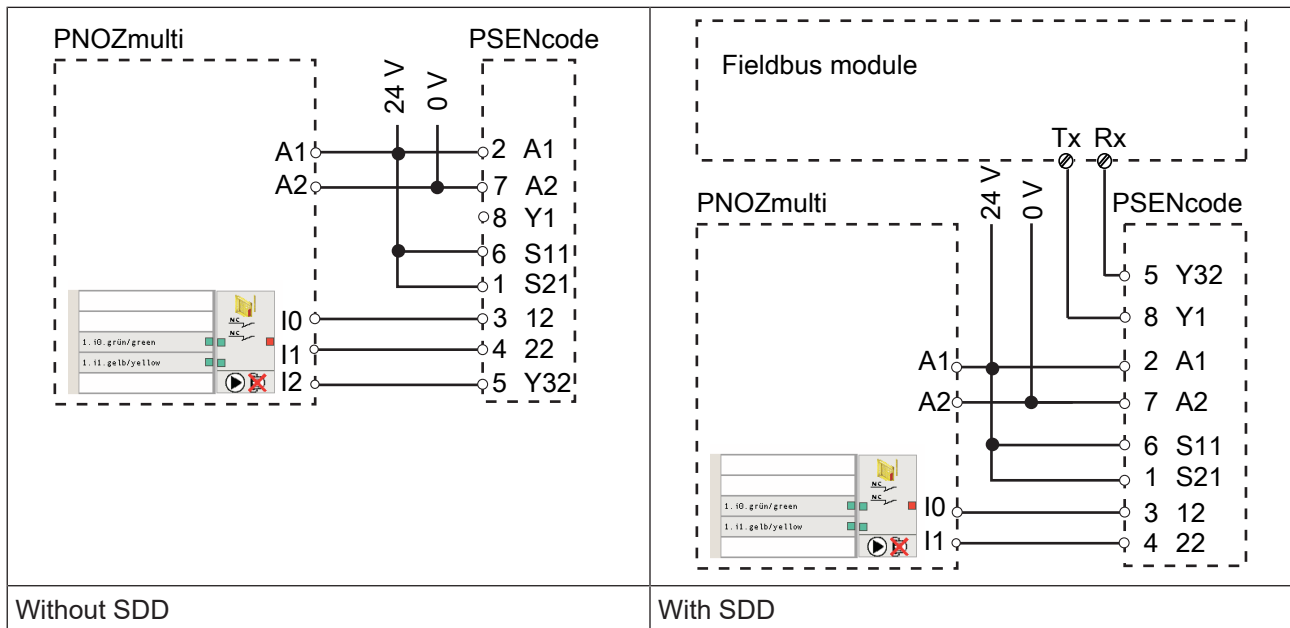

Teaching in the actuator

Teaching in the actuator for the first time:

The first actuator to be detected by the safety switch (see Intended use) is taught in automatically as soon as it is brought into the response range.

To teach in a new actuator:

A maximum of 8 learning procedures are possible.

1. The actuator that is to be taught in must be brought into the safety switch's response range as the only transponder. As soon as the actuator is detected, the "Safety Gate" LED will flash yellow.
2. After 20 s has elapsed, the "Safety Gate" LED turns to quick yellow flashes. Trigger a system reset in the next 120 s by interrupting the power supply.
3. When the supply voltage is switched back on, the learning procedure is complete and the number of permitted additional learning procedures is reduced by 1.



NOTICE

- The actuator must not be removed during the learning procedure.
- It is no longer possible to re-teach this actuator on the same safety switch.

Installation



DANGER!

Risk of sparking due to electrostatic charging of the safety switch in the potentially explosive area

In order to avoid electrostatic charging, clean the safety switch with a damp cloth.

Do not expose the safety switch to high charge-generating processes.



DANGER!

Risk of damage due to mechanical load. Live components on the safety switch in the potentially explosive area may become exposed

Protect the edges of the safety switch base from shock. This can be achieved by full face installation (see [Installation \[23\]](#)).

Protect the plug-in connector on the safety switch from shock (e.g by using the PSEN cs1/2 bracket cable fix, see [Order references for accessories \[34\]](#)).

Please note the information given in the "Installation" section.

- ▶ Any metallic parts (also accessories) must be connected to the equipotential bonding in case of a risk of charging.
- ▶ Make sure that the earthing is in accordance with the specifications in EN 60079-14.



CAUTION!

Potential loss of safety function due to changed device properties

The unit's properties may be affected if installed in an environment containing electrically or magnetically conductive material.

- Please check the operating distances and the assured release distance.

- ▶ The safety switch and actuator should be installed opposite each other in parallel.
 - Make sure that the actuator is aligned to the marking on the sensor that guarantees the operating distance required by the plant design (see [Operating distances \[12\]](#)).
- ▶ Safety switches and actuators should be permanently secured using M5 safety screws with a flat head (e.g. M5 cheese-head or pan head screws).
- ▶ Protect the actuator from contamination.
- ▶ Torque setting: Please note the information provided under [Technical details \[28\]](#).
- ▶ The distance between two safety switches must be maintained (see [Technical details \[28\]](#)).
- ▶ Make sure that the safety switch and actuator cannot be used as an end stop.

- ▶ Please note the installation measures in accordance with EN ISO 14119 for a safety switch design 4 and with level of coding High.
- ▶ For simpler installation, the mounting brackets (see [Order reference for Accessories \[34\]](#)) can be used.
- ▶ If using angled connector plugs, note the defined angle of the cable routing.



CAUTION!

Possible loss of the safety function by changing the release distance S_{ar} with non-flush installation

Installing the safety switch non-flush within electrically or magnetically conductive material, the value for the assured release distance S_{ar} can change.

- Check the assured release distance S_{ar} .

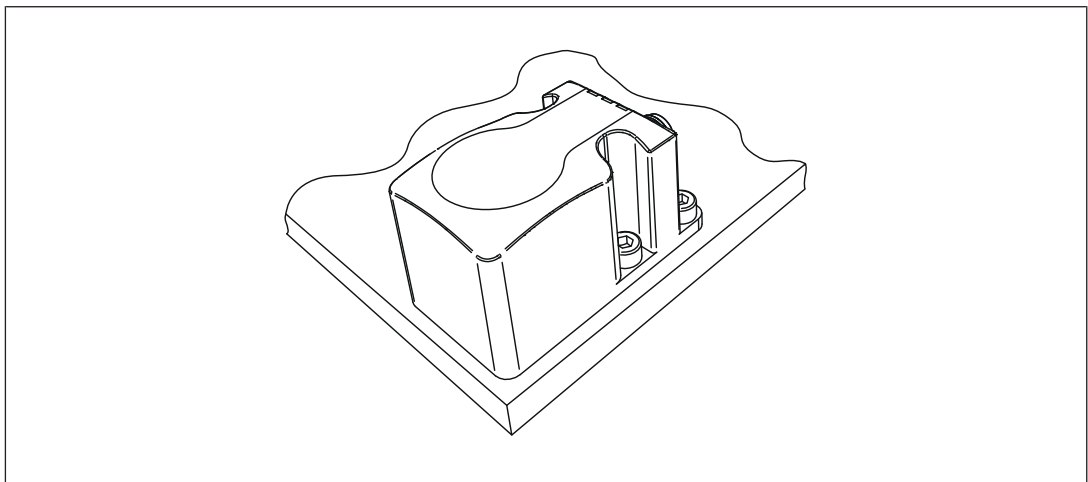

Installation example:

The full face of the safety switch is installed on the subplate.

As a result, the edges of the safety switch base are protected from shock.

Procedure:

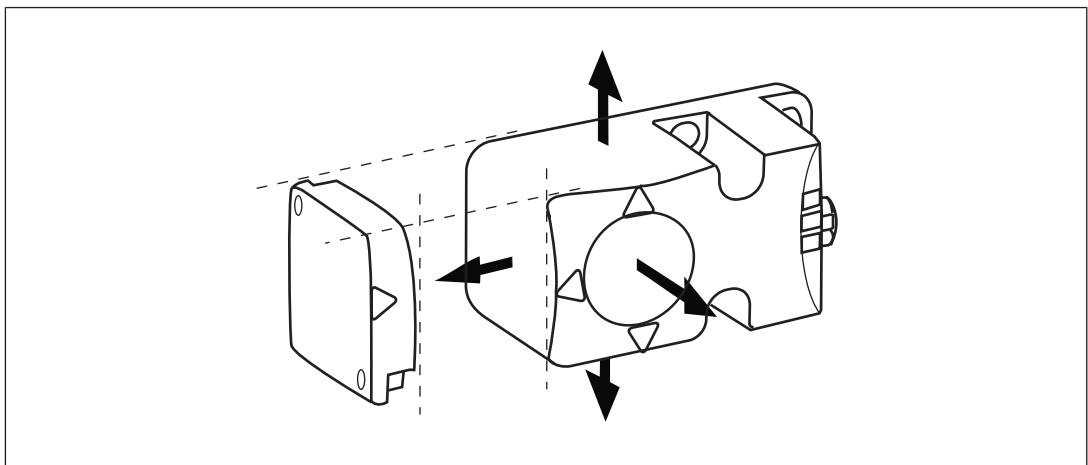





Fig.: Sensing faces on the sensor

1. Drill holes (for M5 screws) in the mounting surface to secure the actuator and sensor (see [Dimensions in mm](#)  27).
2. Use a screw to fix the sensor to the mounting surface.
Make sure that the sensor marking that is to be used for operation can be operated using the actuator from the right side.
3. Do not fully tighten the second screw on the safety switch.
4. Use a screw to fix the actuator to the mounting surface.
Make sure that the actuator with the printed side points towards the marking on the sensor.
5. Do not fully tighten the second screw on the actuator.
6. Align the safety switch and tighten the screws.
7. Align the actuator and tighten the screws.

Periodic test

- ▶ Make sure that the work is **not** performed in an explosive atmosphere.
- ▶ Carry out a monthly function test on the safety switch and actuator.
- ▶ Always test the function with a connected evaluation device.
- ▶ The safety function may only be checked by qualified personnel.
- ▶ Refer to the notes on checking the safety switch in EN 60079-17 and EN 60079-19.

Adjustment

- ▶ The stated operating distances (see [Technical details](#)  28) only apply when the safety switch and actuator are installed facing each other in parallel. Operating distances may deviate if other arrangements are used.
- ▶ Note the maximum permitted lateral and vertical offset (see [Operating distances](#)  12 and [Lateral and vertical offset](#)  13).

ATEX installation and operating regulations (X)



WARNING!

Risk of damage due to mechanical load. Live components on the safety switch in the potentially explosive area may become exposed.

Threat to life!

- Protect the edges of the safety switch base from shock. This can be achieved by full face installation, for example (see [Installation example](#)).
- Please also refer to the additional information in the [Installation](#)  23 section.

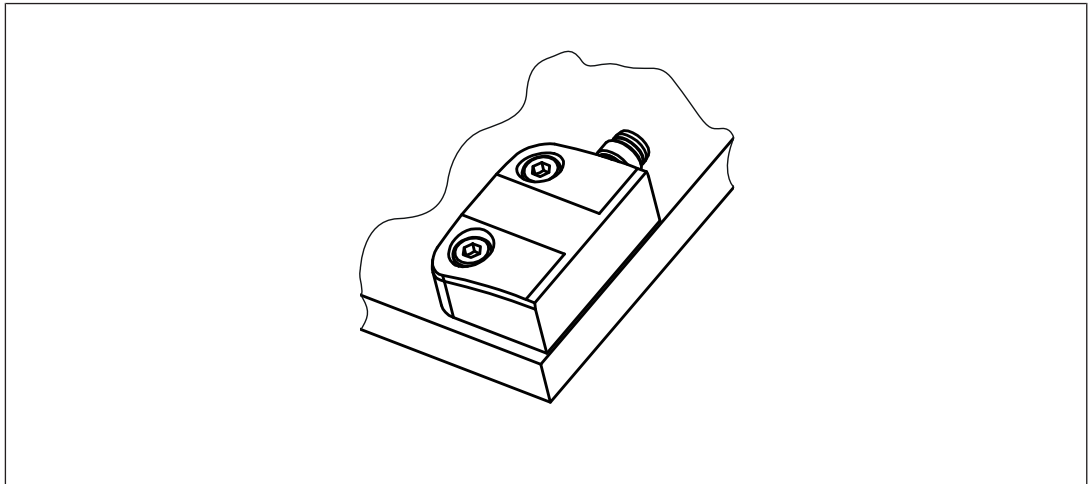

Installation example:

The full face of the safety switch is installed on the subplate.

As a result, the edges of the safety switch base are protected from shock.

The following additional regulations apply:

- ▶ The connector must be protected from mechanical impacts in accordance with EN 60079-0 section 26.4.2.
- ▶ The ambient temperature must be in the temperature range specified in [Technical details](#) [28]
- ▶ Protect the plug-in connection against accidental removal (see Wiring).
- ▶ Attach a warning to the cable box:
 - "Warning - do not separate when energised"
 - "Warning - do not separate when energised".



DANGER!

Risk of sparking due to electrostatic charging of the safety switch in the potentially explosive area

In order to avoid electrostatic charging, clean the safety switch with a damp cloth.

Do not expose the safety switch to high charge-generating processes.



DANGER!

Risk of damage due to mechanical load. Live components on the safety switch in the potentially explosive area may become exposed

Protect the edges of the safety switch base from shock. This can be achieved by full face installation (see [Installation](#) [23]).

Protect the plug-in connector on the safety switch from shock (e.g by using the PSEN cs1/2 bracket cable fix, see [Order references for accessories](#) [34]).

Please note the information given in the "Installation" section.

Operation



NOTICE

The safety functions should be checked after initial commissioning and each time the plant/machine is changed. The safety functions may only be checked by qualified personnel.

Status indicators:

- ▶ "Power/Fault" LED lights up green: The unit is ready for operation
- ▶ "Safety Gate" LED lights up yellow: Actuator is within the response range
- ▶ "Input" LED lights up yellow: There is a high signal at both inputs

Fault indicator:

- ▶ "Input" LED flashes yellow: the signal switches from high to low at one input, while a high signal remains on the other input (partial operation).
Remedy: Open both channels of the input circuit.
- ▶ "Power/Fault" LED lights up red: Error message
Remedy: Rectify fault and interrupt power supply.

Dimensions in mm

Safety switch

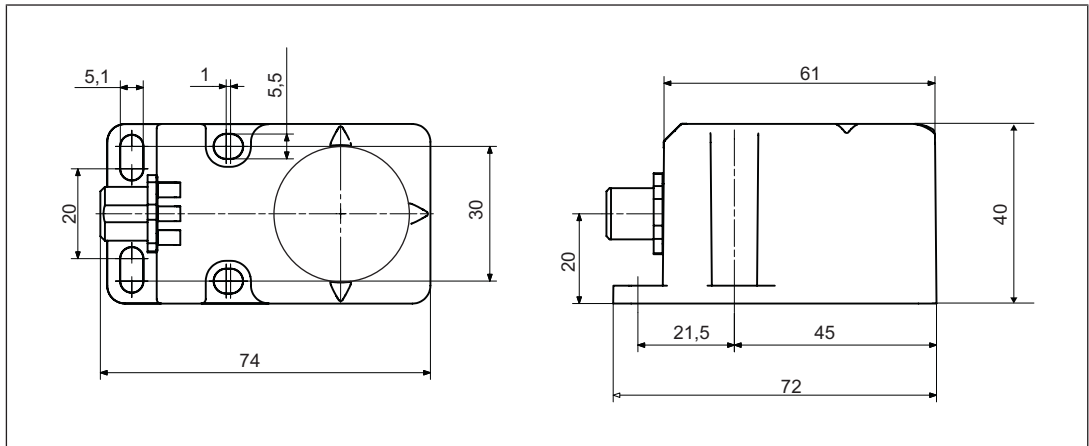

Actuator

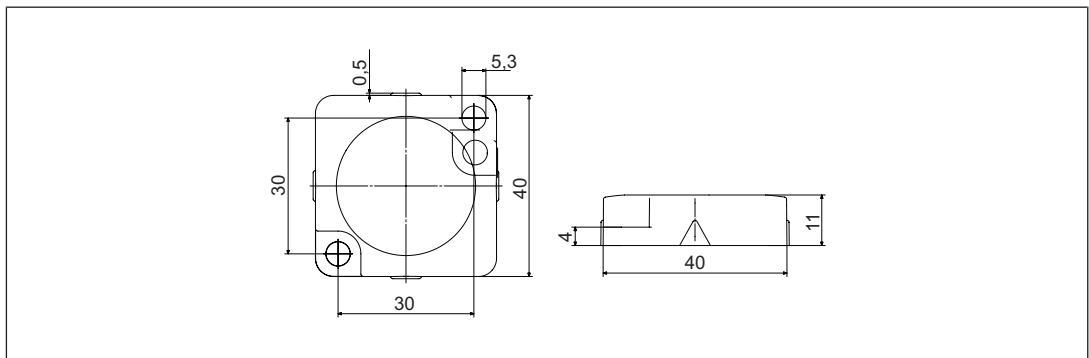

Technical details safety switch

Where standards are undated, the 2025-09 valid editions apply.

General	
Certifications	ATEX, CE, EAC, ECOLAB, FCC, IC, TÜV, UKCA, cULus Listed, electrosuisse
Sensor's mode of operation	Transponders
Coding level in accordance with EN ISO 14119	High
Design in accordance with EN ISO 14119	4
Classification in accordance with EN 60947-5-3	PDDb
Pilz coding type	fully coded
Transponders	
Frequency band	122 kHz - 128 kHz
Max. transmitter output	15 mW
Electrical data	
Supply voltage	
Voltage	24 V
Kind	DC
Voltage tolerance	-20 %/+20 %
Output of external power supply (DC)	2 W
Max. inrush current at UB	0,12 A
Max. switching frequency	3 Hz
Max. cable capacitance at the safety outputs	
No-load, PNOZ with relay contacts	40 nF
PNOZmulti, PNOZelog, PSS	70 nF
No-load current	50 mA
Inputs	
Quantity	2
Voltage at inputs	24 V DC
Input current range	5 mA
Max. overall cable resistance R _{lmax}	
Single-channel at UB DC	1000 Ohm
Semiconductor outputs	
OSSD safety outputs	2
Signal outputs	1
Switching current per output	500 mA
Breaking capacity per output	12 W
Potential isolation from system voltage	No
Short circuit-proof	Yes
Residual current at outputs	10 µA
Voltage drop at OSSDs	3,5 V
Lowest operating current	0 mA
Utilisation category in accordance with EN 60947-1	DC-12

Times	
Max. test pulse duration, safety outputs	450 μs
Switch-on delay	
after UB is applied	1 s
Inputs typ.	13 ms
Inputs max.	20 ms
Actuator typ.	60 ms
Actuator max.	150 ms
Delay-on de-energisation	
Inputs typ.	15 ms
Inputs max.	20 ms
Actuator typ.	40 ms
Actuator max.	260 ms
Risk time in accordance with EN 60947-5-3	260 ms
Supply interruption before de-energisation	20 ms
Simultaneity, channel 1 and 2 max.	∞
Environmental data	
ATEX certification	SEV 12 ATEX 0122 X
ATEX category, gas	II 3G Ex ec mc IIC 90°C(T5) Gc
ATEX category, dust	II 3D Ex mc tc IIIC T90°C Dc
Application area	X: -25°C \leq ta \leq +40°C
Ambient temperature	
in accordance with the standard	EN 60068-2-14
Temperature range	-25 - 40 °C
Max. at max. operating height	+40 °C
Max. at operating height < 2000 m	+40 °C
Storage temperature	
in accordance with the standard	EN 60068-2-1/-2
Climatic suitability	
in accordance with the standard	EN 60068-2-78
Humidity	93 % r. h. at 40 °C
Max. operating height above SL	4000 m
EMC	EN 60947-5-3
Vibration	
in accordance with the standard	EN 60947-5-2
Frequency	10 - 55 Hz
Amplitude	1 mm
Shock stress	
in accordance with the standard	EN 60947-5-2
Acceleration	30g
Duration	11 ms
Airgap creepage	
Overvoltage category	III
Pollution degree	3
Rated insulation voltage	75 V
Rated impulse withstand voltage	0,8 kV

Environmental data

Protection type

Housing IP67

Operating distancesAssured operating distance S_{ao} 15 mmTypical operating distance S_o 21 mmAssured release distance S_{ar} 40 mmTypical release distance S_r 32 mm

Repetition accuracy switching distances 10 %

Change of operating distance with temperature changes $\pm 0,01\text{mm}/^\circ\text{C}$

Typ. hysteresis 3 mm

Mechanical data

Actuator 1 PSEN cs2.1

Min. distance between safety switches 400 mm

Sensor flush installation in accordance with EN 60947-5-2 yes, follow installation guidelines

Connection type M12, 8-pin male connector

Material

Top PBT

Max. fixing screws torque settings 1 Nm

Dimensions

Height 75 mm

Width 40 mm

Depth 40 mm

Weight of safety switch 130 g

Weight 130 g

Technical details actuator**General**

Certifications CE, TÜV, UKCA, cULus Listed

Sensor's mode of operation Transponders

Coding level in accordance with EN ISO 14119 High

Pilz coding type fully coded

Transponders

Frequency band 122 kHz - 128 kHz

Environmental data

Ambient temperature

in accordance with the standard EN 60068-2-14

Temperature range -25 - 70 °C

Storage temperature

in accordance with the standard EN 60068-2-1/-2

Temperature range -40 - 85 °C

Environmental data

Climatic suitability

in accordance with the standard	EN 60068-2-78
Humidity	93 % r. h. at 40 °C

EMC	EN 60947-5-3
-----	---------------------

Vibration

in accordance with the standard	EN 60947-5-2
Frequency	10 - 55 Hz
Amplitude	1 mm

Shock stress

in accordance with the standard	EN 60947-5-2
Acceleration	30g
Duration	11 ms

Protection type

Housing	IP6K9K
---------	---------------

Mechanical data

Material

Top	PBT
-----	------------

Max. fixing screws torque settings	1 Nm
------------------------------------	-------------

Dimensions

Height	11 mm
Width	40 mm
Depth	40 mm

Weight	20 g
--------	-------------

Classification in accordance with ZVEI, CB24I

The following tables describe the classes and specific values of the product interface and the classes of interfaces compatible with it. The classification is described in the ZVEI position paper "Classification of Binary 24 V Interfaces - Functional Safety aspects covered by dynamic testing".

Input**Interfaces**

Drain

Class	C2
-------	-----------

Source

Class	C2, C3
-------	---------------

Drain parameters

Max. test pulse duration	500 µs
Min. test pulse interval	1,25 ms
Min. input resistance	6,6 kOhm
Max. capacitive load	10 pF

Single-pole output

Interfaces

Source

Class C2

Drain

Class C1, C2

Source parameters

Max. test pulse duration 450 µs

Max. rated current 0,5 A

Max. capacitive load 40 nF

Safety characteristic data



NOTICE

You must comply with the safety characteristic data in order to achieve the required safety level for your plant/machine.

Operating mode	EN ISO 13849-1: 2023	EN ISO 13849-1: 2023	EN IEC 62061 SIL CL/max.	EN IEC 62061 61508	EN/IEC 61511 61508	EN/IEC 61511 61508	EN ISO 13849-1: 2023
	PL	Category	SIL	PFH [1/h]	SIL	PFD	T _M [year]
2-ch. OSSD	PL e	Cat. 4	SIL CL 3	4,10E-09	–	1,10E-04	20

Explanatory notes for the safety-related characteristic data:

- ▶ T_M is the maximum mission time in accordance with EN ISO 13849-1. The value also applies as the retest interval in accordance with EN IEC 61508-6 and EN IEC 61511 and as the proof test interval and mission time in accordance with EN IEC 62061.

All the units used within a safety function must be considered when calculating the safety characteristic data.



INFORMATION

A safety function's SIL/PL values are **not** identical to the SIL/PL values of the products used and may differ from these.

Supplementary data

Radio approval

USA/Canada

FCC ID: VT8-PSENCs1
IC: 7482A-PSENCs1

FCC/IC-Requirements:

This product complies with Part 15 of the FCC Rules and with Industry Canada licence-exempt RSS standards.

Operation is subject to the following two conditions:

- 1) this product may not cause harmful interference, and
- 2) this product must accept any interference received, including interference that may cause undesired operation.

Changes or modifications made to this product not expressly approved by Pilz may void the FCC authorization to operate this equipment.

NOTE: This equipment has been tested and found to comply with the limits for a Class A digital device, pursuant to Part 15 of the FCC Rules. These limits are designed to provide reasonable protection against harmful interference when the equipment is operated in a commercial environment. This equipment generates, uses, and can radiate radio frequency energy and, if not installed and used in accordance with the instruction manual, may cause harmful interference to radio communications. Operation of this equipment in a residential area is likely to cause harmful interference in which case the user will be required to correct the interference at his own expense.

Le présent produit est conforme aux CNR d'Industrie Canada applicables aux appareils radio exempts de licence. L'exploitation est autorisée aux deux conditions suivantes:

- (1) le produit ne doit pas produire de brouillage, et
- (2) l'utilisateur de le produit doit accepter tout brouillage radioélectrique subi, même si le brouillage est susceptible d'en compromettre le fonctionnement.

Order reference

Safety switch

Product type	Features	Product ID
PSEN cs2.13p/ATEX 1 switch	Coded safety switch PSENcode, fully coded, ATEX certificate, 8-pin M12 male connector, series connection, large design	540155

Actuator

Product type	Features	Product ID
PSEN cs2.1 1 actuator	Actuator, coded, for coded safety switches PSENcode	540180

Complete systems

Product type	Features	Product ID
PSEN cs2.13p / PSEN cs2.1 / ATEX	Coded safety switch PSENcode, fully coded, with safety switch and actuator, ATEX certificate, 8-pin M12 male connector, series connection, large design, incl. 1 pair CABLE/M12/CLIP for securing 1 M12 plug-in connector	540105

Accessories

Installation material

Product type	Features	Order no.
PSEN bracket	Mounting bracket	532110
PSEN mag/cs bracket straight	Mounting aid	532111
PSEN screw M5x10 10pcs	Safety screws made from stainless steel with one-way slot	540311
PSEN screw M5x20 10pcs	Safety screws made from stainless steel with one-way slot	540312
PSEN cs1/2 bracket cable fix	Mechanical protection against defeat, protecting against unauthorised cable disconnection or damage for safety switches PSENcode cs1/2, PSENcode cs5/6 M12, PSENslock	532112

Cable

Product type	Connection 1	Connection 2	Length	Order no.
PSEN cable M12-8sf	straight, M12, 8-pin, socket	Open cable	3 m	540319
			5 m	540320
			10 m	540321
			20 m	540333
			30 m	540326

Product type	Connection 1	Connection 2	Length	Order no.
PSEN cable M12-8af	Angled, M12, 8-pin, socket	Open cable	3 m	540322
			5 m	540323
			10 m	540324
			30 m	540325
PSEN cable M12-8sf M12-8sm	straight, M12, 8-pin, socket	straight, M12, 8-pin, pin	2 m	540340
			5 m	540341
			10 m	540342
			20 m	540343
			30 m	540344

Product type	Features	Product ID
CABLE/M12/CLIP	Manipulation protection for plug-in connector and protection against unintended disconnection, for single use, 4 pieces for securing 4 M12 plug-in connectors	C1000079

Series connection

Product type	Connection X1	Connection X2	Connection X3	Order no.
PSEN Y junction M12 SENSOR	M12, 8-pin, pin	M12, 8-pin, socket	M12, 8-pin, socket	540315
PSEN Y junction M12 cable channel	M12, 8-pin, pin	M12, 8-pin, socket	M12, 8-pin, socket	540316
PSEN T junction M12	M12, 8-pin, socket	M12, 8-pin, pin	M8, 4-pin, pin	540331
PSEN Y junction M8-M12/ M12 PIGTAIL	M12, 8-pin, socket	M12, 8-pin, pin	M8, 8-pin, socket	540337
PSEN Y junction M12-M12/ M12 PIGTAIL	M12, 8-pin, socket	M12, 8-pin, pin	M12, 8-pin, socket	540338

Product type	Features	Product ID
PDP67 F 4 code	Decentralised passive junction	773603
PDP67 F 4 code VA	Decentralised passive junction, V2A ring nut	773613

Safety Device Diagnostics

Product type	Features	Connection type	Order no.
PSEN ix2 F4 code	Interface for connecting max. 4 PSEN safety sensors	Spring-loaded terminal	535111
PSEN ix2 F8 code	Interface for connecting max. 8 PSEN safety sensors	Spring-loaded terminal	535112
SDD ES ETH	Modbus/TCP fieldbus module for Safety Device Diagnostics	Spring-loaded terminal	540130
SDD ES Profibus	Profibus fieldbus module for Safety Device Diagnostics	Spring-loaded terminal	540132
SDD ES Profinet	Profinet fieldbus module for Safety Device Diagnostics	Spring-loaded terminal	540138

EC declaration of conformity

This product/these products meet(s) the requirements of the following directives of the European Parliament and of the Council.

- ▶ 2006/42/EC on machines
- ▶ 2014/34/EU (ATEX)
- ▶ 2014/53/EU on radio equipment

The complete EC Declaration of Conformity is available on the Internet at www.pilz.com/downloads.

Representative: Pilz GmbH & Co. KG, Felix-Wankel-Str. 2, 73760 Ostfildern, Germany

UKCA-Declaration of Conformity

This product(s) complies with following UK legislation:

- ▶ Supply of Machinery (Safety) Regulations 2008
- ▶ Equipment and Protective Systems Intended for use in Potentially Explosive Atmospheres Regulations 2016
- ▶ Radio Equipment Regulations 2017

The complete UKCA Declaration of Conformity is available on the Internet at www.pilz.com/downloads.

Representative: Pilz Automation Technology, Pilz House, Little Colliers Field, Corby, Northamptonshire, NN18 8TJ United Kingdom, eMail: mail@pilz.co.uk

Support

Technical support is available from Pilz round the clock.

Americas

Brazil

+55 11 97569-2804

Canada

+1 888 315 7459

Mexico

+52 55 5572 1300

USA (toll-free)

+1 877-PILZUSA (745-9872)

Asia

China

+86 400-088-3566

Japan

+81 45 471-2281

South Korea

+82 31 778 3390

Australia and Oceania

Australia

+61 3 95600621

New Zealand

+64 9 6345350

Europe

Austria

+43 1 7986263-444

Belgium, Luxembourg

+32 9 3217570

France

+33 3 88104003

Germany

+49 711 3409-444

Ireland

+353 21 4804983

Italy, Malta

+39 0362 1826711

Scandinavia

+45 74436332

Spain

+34 938497433

Switzerland

+41 62 88979-32

The Netherlands

+31 347 320477

Türkiye

+90 216 5775552

United Kingdom

+44 1536 460866

You can reach our international hotline on:

+49 711 3409-222

support@pilz.com

Pilz develops environmentally-friendly products using ecological materials and energy-saving technologies. Offices and production facilities are ecologically designed, environmentally-aware and energy-saving. So Pilz offers sustainability, plus the security of using energy-efficient products and environmentally-friendly solutions.



We are represented internationally. Please refer to our homepage www.pilz.com for further details or contact our headquarters.

Headquarters: Pilz GmbH & Co. KG, Felix-Wankel-Straße 2, 73760 Ostfildern, Germany
Telephone: +49 711 3409-0, E-Mail: info@pilz.com, Internet: www.pilz.com

PILZ
THE SPIRIT OF SAFETY

CECE, CHRE, CMSE®, INDUSTRIAL Pi®, Leansafe®, Myze®, PAS4000®, PAScal®, PASconfig®, Pilz®, PIT®, PMCPirimo®, PMCProtego®, PMCTiempo®, PMP®, PMi®, PNOZ®, Primo®, PSEN®, PSS®, PVIS®, SafetyBUS p®, SafetyNET p®, THE SPIRIT OF SAFETY® are registered and protected trademarks of Pilz GmbH & Co. KG in some countries. We would point out that product features may vary from the details stated in this document, depending on the status at the time of publication and the scope of the equipment. We accept no responsibility for the validity, accuracy and entirety of the text and graphics presented in this information. Please contact our Technical Support if you have any questions.

21133-EN-22, 2025-12 Printed in Germany
© Pilz GmbH & Co. KG, 2024