

▶ PNOZ s7

PILZ

THE SPIRIT OF SAFETY

Operating Manual-21399-EN-18

- Safety relays



This document is a translation of the original document.

Where unavoidable, for reasons of readability, the masculine form has been selected when formulating this document. We do assure you that all persons are regarded without discrimination and on an equal basis.

All rights to this documentation are reserved by Pilz GmbH & Co. KG. Copies may be made for the user's internal purposes. Suggestions and comments for improving this documentation will be gratefully received.

CECE®, CHRE®, CMSE®, INDUSTRIAL PI®, Leansafe®, MYZEL®, PAS4000®, PAS-cal®, PASconfig®, Pilz®, PIT®, PMCprimo®, PMCprotego®, PM Ctendo®, PMD®, PMI®, PNOZ®, Primo®, PSEN®, PSS®, PVIS®, SafetyBUS p®, SafetyEYE®, SafetyNET p®, THE SPIRIT OF SAFETY® are registered and protected trademarks of Pilz GmbH & Co. KG in some countries.



SD means Secure Digital

Introduction	5
Validity of documentation	5
Using the documentation	5
Definition of symbols	5
Safety	6
Intended use	6
Safety regulations	6
Safety assessment	6
Use of qualified personnel	7
Warranty and liability	7
Disposal	7
For your safety	7
Unit features	8
Safety features	8
Block diagram/terminal configuration	9
Function description	9
Timing diagram	9
Installation	10
Wiring	10
Preparing for operation	11
Application examples	12
Operation	13
Status indicators	14
Error indicators	14
Faults - malfunctions	14
Dimensions in mm	14
Technical details	15
Safety characteristic data	20
Classification according to ZVEI, CB24I	21
Supplementary data	22
Service life graph	22
Operating height in accordance with EN 60664-1	24

Remove plug-in terminals	25
Order reference	25
EU/EC declaration of conformity	25
UKCA-Declaration of Conformity	26

Introduction

Validity of documentation

This documentation is valid for the product PNOZ s7. It is valid until new documentation is published.

This operating manual explains the function and operation, describes the installation and provides guidelines on how to connect the product.

Using the documentation

This document is intended for instruction. Only install and commission the product if you have read and understood this document. The document should be retained for future reference.

Definition of symbols

Information that is particularly important is identified as follows:



DANGER!

This warning must be heeded! It warns of a hazardous situation that poses an immediate threat of serious injury and death and indicates preventive measures that can be taken.



WARNING!

This warning must be heeded! It warns of a hazardous situation that could lead to serious injury and death and indicates preventive measures that can be taken.



CAUTION!

This refers to a hazard that can lead to a less serious or minor injury plus material damage, and also provides information on preventive measures that can be taken.



NOTICE

This describes a situation in which the product or devices could be damaged and also provides information on preventive measures that can be taken. It also highlights areas within the text that are of particular importance.

**INFORMATION**

This gives advice on applications and provides information on special features.

Safety**Intended use**

The contact expansion module PNOZ s7 meets the requirements of EN 60947-5-1 and EN 60204-1. It is used to increase the number of instantaneous safety contacts available on a base unit. Base units are all safety relays with feedback loop.

The max. achievable safety level depends on the base unit. The expansion module may not exceed this. The safety-related characteristic values stated under [safety-related characteristic data](#) [ 20] can only be achieved if the base unit also exhibits these safety characteristic values.

Improper use

The following is deemed improper use in particular:

- ▶ Any component, technical or electrical modification to the product,
- ▶ Use of the product outside the areas described in this operating manual,
- ▶ Use of the product outside the technical details (see chapter entitled [Technical Details](#) [ 15]).

**NOTICE****EMC-compliant electrical installation**

The product is designed for use in an industrial environment. The product may cause interference if installed in other environments. If installed in other environments, measures should be taken to comply with the applicable standards and directives for the respective installation site with regard to interference.

Safety regulations**Safety assessment**

Before using a unit, a risk assessment is required in accordance with the Machinery Regulation.

Connecting additional units may result in further risks. Take the necessary measures to protect against corruption.

The product as an individual component fulfils the functional safety requirements in accordance with EN ISO 13849 and EN IEC 62061. However, this does not guarantee the functional safety of the overall plant/machine. To achieve the relevant safety level of the overall plant/machine's required safety functions, each safety function needs to be considered separately.

Use of qualified personnel

The products may only be assembled, installed, programmed, commissioned, operated, decommissioned and maintained by persons who are competent to do so.

A competent person is a qualified and knowledgeable person who, because of their training, experience and current professional activity, has the specialist knowledge required. In order to inspect, assess and handle products, devices, systems, plant and machinery, this person must be familiar with the state of the art and the applicable national, European and international laws, directives and standards.

It is the company's responsibility only to employ personnel who

- ▶ Are familiar with the basic regulations concerning health and safety / accident prevention,
- ▶ Have read and understood the information provided in the section entitled Safety
- ▶ Have a good knowledge of the generic and specialist standards applicable to the specific application.

Warranty and liability

All claims to warranty and liability will be rendered invalid if

- ▶ The product was used contrary to the purpose for which it is intended,
- ▶ Damage can be attributed to not having followed the guidelines in the manual,
- ▶ Operating personnel are not suitably qualified,
- ▶ Any type of modification has been made (e.g. exchanging components on the PCB boards, soldering work etc.).

Disposal

- ▶ In safety-related applications, please comply with the mission time T_M stated in the safety-related characteristic data.
- ▶ When decommissioning, please comply with local regulations regarding the disposal of electronic devices (e.g. Electrical and Electronic Equipment Act).

For your safety

The unit meets all the necessary conditions for safe operation. However, please note the following:

- ▶ Note for overvoltage category III: If voltages higher than low voltage (>50 VAC or >120 VDC) are present on the unit, connected control elements and sensors must have a rated insulation voltage of at least 250 V.

Unit features

- ▶ Positive-guided relay outputs:
 - 4 safety contacts (N/O), instantaneous
 - 1 auxiliary contact (N/C), instantaneous
- ▶ LED for:
 - Input status, channel 1
 - Input status, channel 2
 - Switch status of the safety contacts
 - Fault
- ▶ Plug-in connection terminals (either spring-loaded terminal or screw terminal)
- ▶ See order reference for unit types

Safety features

The unit meets the following safety requirements:

- ▶ The contact expansion module expands an existing circuit. As the output relays are monitored via the base unit's feedback loop, the safety functions on the existing circuit are transferred to the contact expansion module.
- ▶ The safety function remains effective in the case of a component failure.
- ▶ Earth fault in the feedback loop:
Detected, depending on the base unit that is used.
- ▶ Earth fault in the input circuit:
The output relays de-energise and the safety contacts open.

Block diagram/terminal configuration

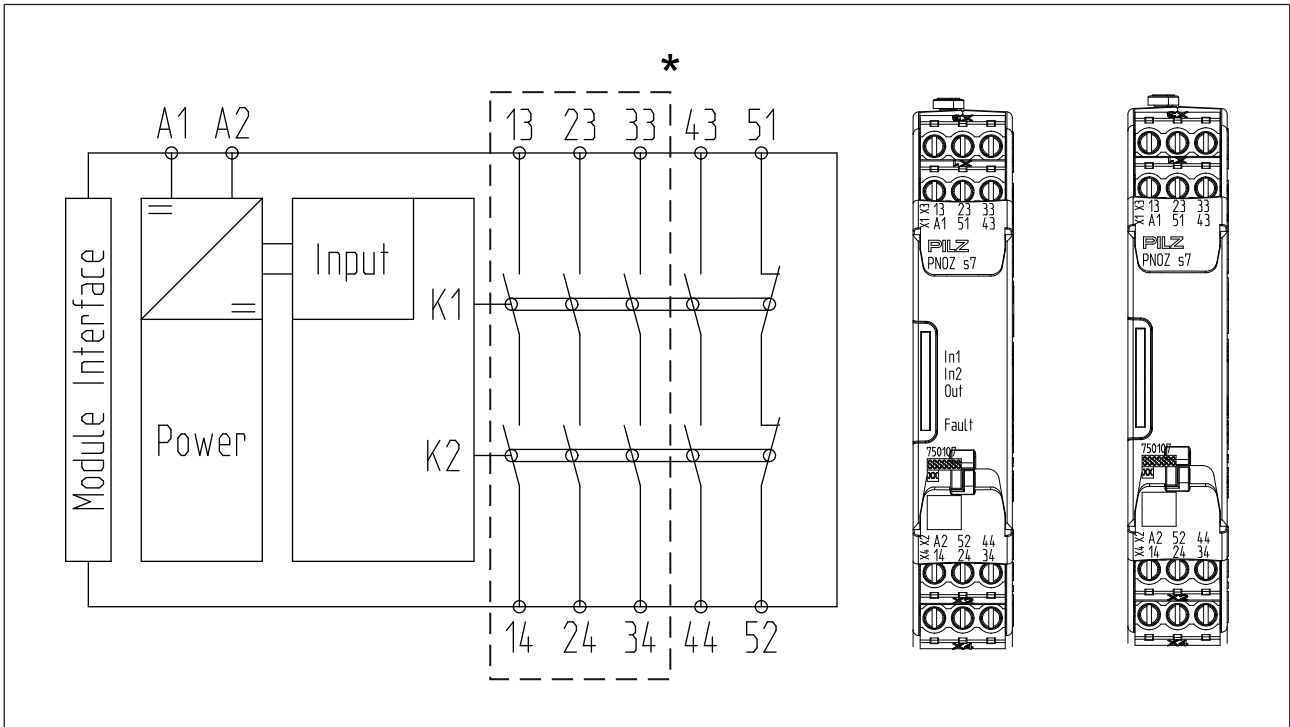

Fig.: Centre: Front view with cover, right: Front view without cover

*Safe separation from non-marked area in accordance with EN 60947-1, 6 kV, basic insulation between all safety contacts.

Function description

with PNOZsigma base unit:

- ▶ Dual-channel operation via PNOZsigma connector

without PNOZsigma base unit:

- ▶ Single-channel operation: one input circuit affects the output relays

Timing diagram

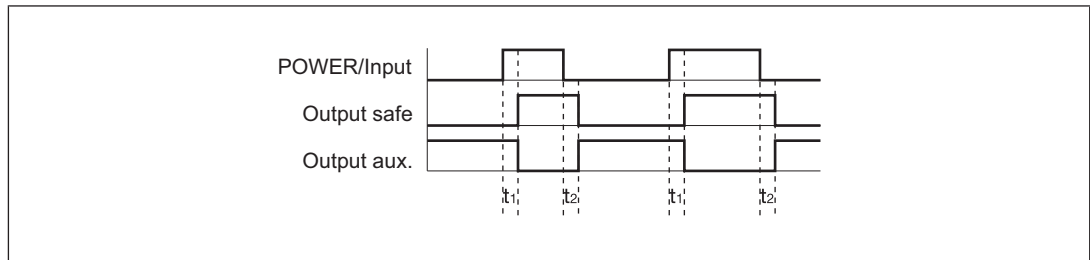

Legend

- ▶ POWER/Input: Supply voltage/input circuit
- ▶ Output safe: Safety contacts
- ▶ Output aux.: Auxiliary contacts
- ▶ t_1 : Switch-on delay
- ▶ t_2 : Delay-on de-energisation

Installation



NOTICE

Protection against manipulation

Protect the product from unauthorised access.

Install contact expansion module without base unit:

- ▶ Ensure that the plug terminator is inserted at the side of the unit.

Connect base unit and PNOZsigma contact expansion module:

- ▶ Remove the plug terminator at the side of the base unit and at the contact expander module
- ▶ Connect the base unit and the contact expansion module using the connector supplied, before mounting the units to the DIN rail.

Control cabinet installation

- ▶ Install the safety relay in a control cabinet with a protection type of at least IP54.
- ▶ Use the notch on the rear of the unit to attach it to a DIN rail (35 mm).
- ▶ When installed vertically: secure the device by using a fixing element (e.g. retaining bracket or end angle).
- ▶ Push the unit upwards or downwards before lifting it from the DIN rail.

Wiring

Please note:

- ▶ Information given in the "[Technical details \[15\]](#)" must be followed.
- ▶ Outputs 13-14, 23-24, 33-34, 43-44 are safety contacts; outputs 51 -52 are auxiliary contacts (e.g. for display).
- ▶ Auxiliary contact 51-52 should **not** be used for safety circuits!
- ▶ To prevent contact welding, a fuse should be connected before the output contacts (see [Technical details \[15\]](#)).
- ▶ Calculation of the max. cable length l_{\max} in the input circuit:

$$l_{\max} = \frac{R_{l_{\max}}}{R_l / \text{km}}$$

$R_{l_{\max}}$ = max. overall cable resistance (see [Technical details \[15\]](#))

R_l / km = cable resistance/km

- ▶ Use copper wiring with a temperature stability of 75 °C.
- ▶ To prevent EMC interferences (particularly common-mode interferences) the measures described in EN 60204-1 must be executed. This includes the separate routing of cables of the control circuits (input, start and feedback loop) from other cables for energy transmission or the shielding of cables, for example.
- ▶ Adequate protection circuit must be provided on all output contacts with capacitive and inductive loads.
- ▶ The power supply must comply with the regulations for extra low voltages with protective electrical separation (SELV, PELV) in accordance with VDE 0100, Part 410.

Preparing for operation

Input circuit	Single-channel	Dual-channel
Base unit: Safety relay PNOZ X		
Base unit: Safety relay or programmable safety system, control via semiconductor outputs (24 V DC), e.g. PNOZelog, PNOZmulti, PSS		
Base unit: Programmable safety system, control via dual-pole semiconductor outputs (24 V DC/0 V DC), e.g. PNOZmulti, PSS		

Feedback loop	Base unit: Safety relay PNOZ X	Base unit: Safety relay or programmable safety system with semiconductor input, e.g. PNOZelog, PNOZmulti, PSS
The inputs that evaluate the feedback loop will depend on the base unit and application		

Connection to PNOZsigma base unit/PNOZmulti Mini base unit	Base unit: Safety relay PNOZ-sigma	Base unit: Small control system PNOZmulti Mini
The feedback loop is connected and evaluated via the connector		



INFORMATION

If a base unit and a contact expansion module are linked via the connector, no additional wiring is necessary.
Do not connect A1/A2 to the contact expansion module!

Application examples

Single device

- ▶ Single-channel
- ▶ Driven via safety relay with safety contacts

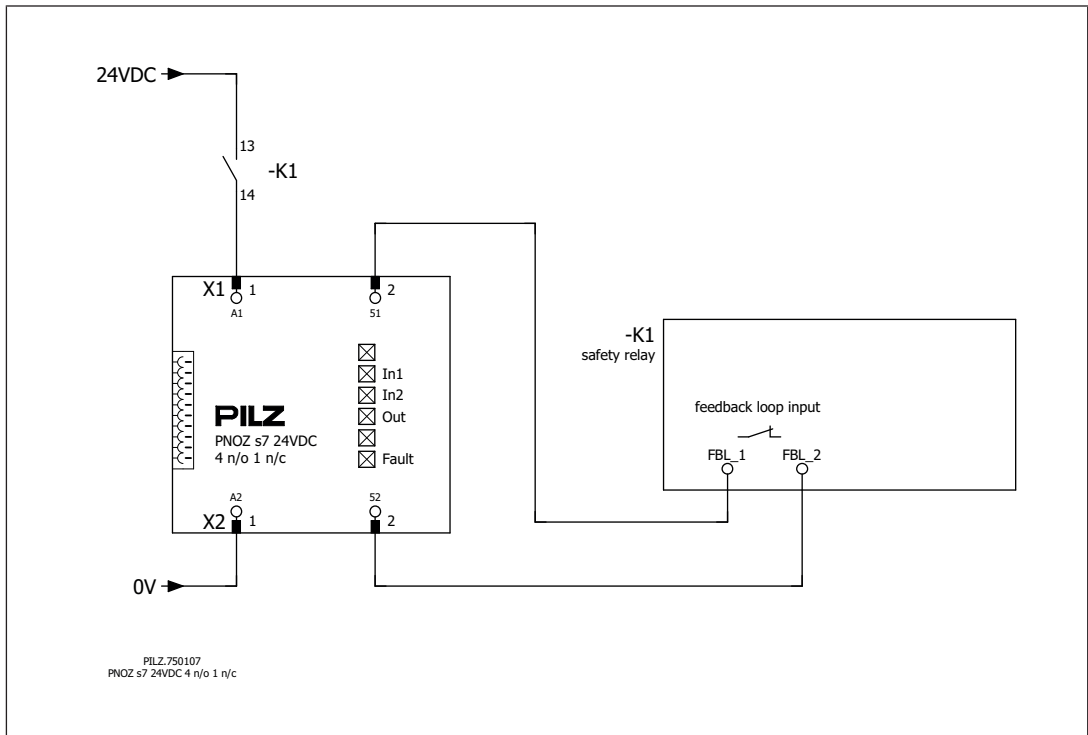

Contact expansion for PNOZ s4

- ▶ Emergency stop
- ▶ Dual-channel
- ▶ with detection of shorts across contacts
- ▶ Monitored start
- ▶ falling edge with feedback loop monitoring

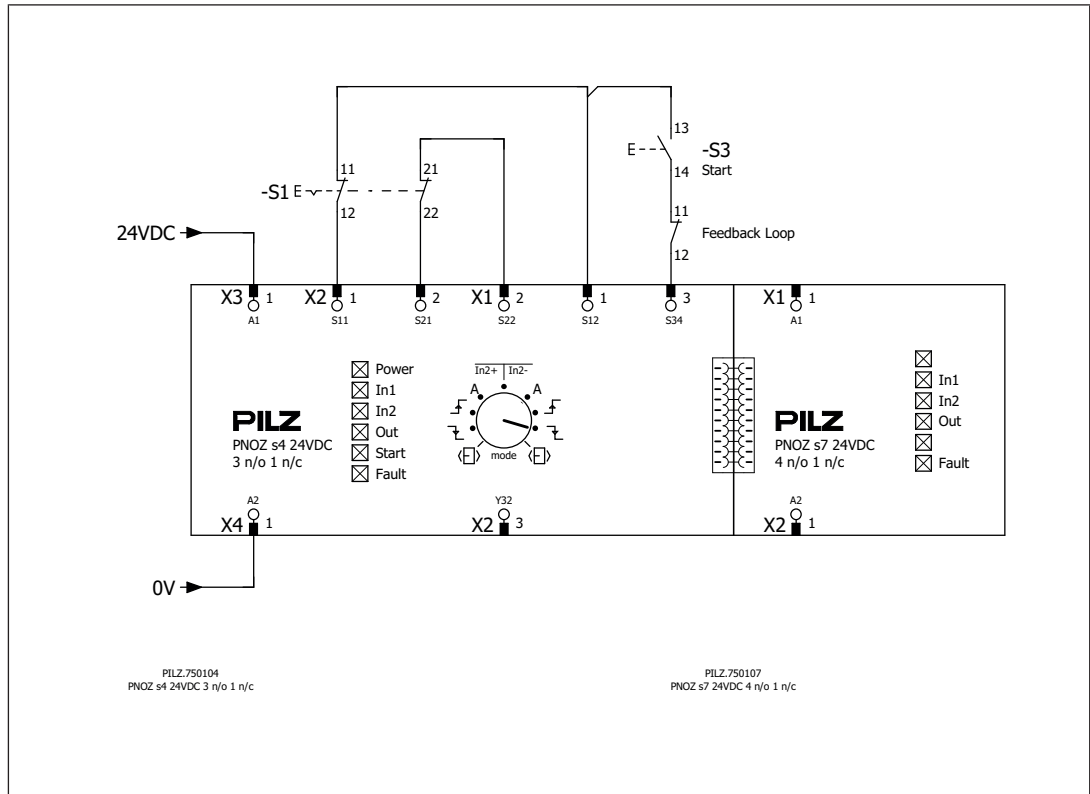

Operation

When the relay outputs are switched on, the mechanical contact on the relay cannot be tested automatically. Depending on the operational environment, measures to detect the non-opening of switching elements may be required under some circumstances.

When the product is used in accordance with the European Machinery Regulation, a check must be carried out to ensure that the safety contacts on the relay outputs open correctly. Open the safety contacts (switch off output) and start the device again, so that the internal diagnostics can check that the safety contacts open correctly

- ▶ For SIL 3/PL e, at least 1x per month
- ▶ For SIL 2/PL d, at least 1x per year



NOTICE

The safety functions should be checked after initial commissioning and each time the plant/machine is changed. The safety functions may only be checked by qualified personnel.

LEDs indicate the status and errors during operation:

 LED on

Status indicators

 **IN1**
Channel 1 actuated.

 **IN2**
Channel 2 actuated.

 **IN1, IN2, OUT**
Safety contacts are closed.

Error indicators

 **FAULT**
Diagnostics: Plug terminator not connected
▶ Remedy: Insert plug terminator, switch supply voltage off and then on again.

Faults - malfunctions

▶ Contact malfunctions: If the contacts have welded, reactivation will not be possible after the input circuit has opened.

Dimensions in mm

*with spring-loaded terminals

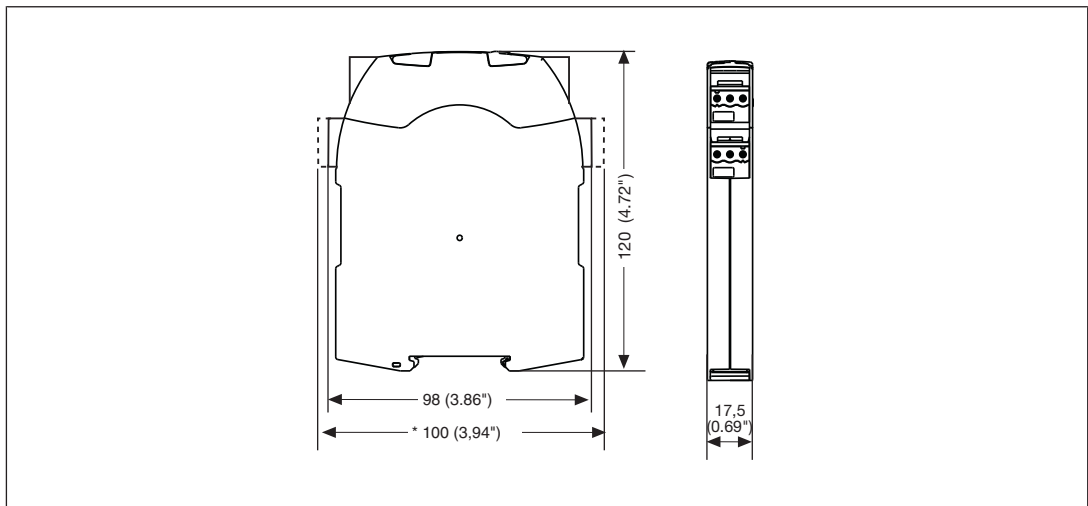

Technical details

Where standards are undated, the 2022-09 valid editions apply.

General	750107	751107	751187
Certifications	CCC, CE, EAC, KOSHA, TÜV, UKCA, cULus Listed	CCC, CE, EAC, KOSHA, TÜV, UKCA, cULus Listed	CCC, CE, EAC, KOSHA, TÜV, UKCA, cULus Listed
Electrical data	750107	751107	751187
Supply voltage			
Voltage	24 V	24 V	24 V
Kind	DC	DC	DC
Voltage tolerance	-20 %/+20 %	-20 %/+20 %	-20 %/+20 %
Output of external power supply (DC)	2 W	2 W	2 W
Residual ripple DC	20 %	20 %	20 %
Duty cycle	100 %	100 %	100 %
Inputs	750107	751107	751187
Quantity	1	1	1
Voltage at			
Input circuit DC	24 V	24 V	24 V
Current at			
Input circuit DC	70 mA	70 mA	70 mA
Max. inrush current impulse			
Current pulse, input circuit	2,7 A	2,7 A	2,7 A
Pulse duration, input circuit	0,1 ms	0,1 ms	0,1 ms
Max. overall cable resistance R _{lmax}			
Single-channel at UB DC	30 Ohm	30 Ohm	30 Ohm
Relay outputs	750107	751107	751187
Number of output contacts			
Safety contacts (N/O), instantaneous	4	4	4
Auxiliary contacts (N/C)	1	1	1
Max. short circuit current I _K	1 kA	1 kA	1 kA
Utilisation category			
in accordance with the standard	EN 60947-4-1	EN 60947-4-1	EN 60947-4-1

Relay outputs	750107	751107	751187
Utilisation category of safety contacts			
AC1 at	240 V	240 V	240 V
Min. current	0,003 A	0,003 A	0,003 A
Max. current	6 A	6 A	6 A
Min. power	0,04 VA	0,04 VA	0,04 VA
Max. power	1.500 VA	1.500 VA	1.500 VA
DC1 at	24 V	24 V	24 V
Min. current	0,003 A	0,003 A	0,003 A
Max. current	6 A	6 A	6 A
Min. power	0,04 W	0,04 W	0,04 W
Max. power	150 W	150 W	150 W
Utilisation category of auxiliary contacts			
AC1 at	240 V	240 V	240 V
Min. current	0,003 A	0,003 A	0,003 A
Max. current	2 A	2 A	2 A
Min. power	0,04 VA	0,04 VA	0,04 VA
Max. power	500 VA	500 VA	500 VA
DC1 at	24 V	24 V	24 V
Min. current	0,003 A	0,003 A	0,003 A
Max. current	2 A	2 A	2 A
Min. power	0,04 W	0,04 W	0,04 W
Max. power	50 W	50 W	50 W
Utilisation category in accordance with the standard			
	EN 60947-5-1	EN 60947-5-1	EN 60947-5-1
Utilisation category of safety contacts			
AC15 at	230 V	230 V	230 V
Max. current	5 A	5 A	5 A
DC13 (6 cycles/min) at	24 V	24 V	24 V
Max. current	5 A	5 A	5 A
Utilisation category of auxiliary contacts			
AC15 at	230 V	230 V	230 V
Max. current	2 A	2 A	2 A
DC13 (6 cycles/min) at	24 V	24 V	24 V
Max. current	2 A	2 A	2 A
Utilisation category in accordance with UL			
Voltage	240 V AC G.U. (same polarity)	240 V AC G.U. (same polarity)	240 V AC G.U. (same polarity)
with current	6 A	6 A	6 A
Voltage	24 V DC G. U.	24 V DC G. U.	24 V DC G. U.
with current	6 A	6 A	6 A

Relay outputs	750107	751107	751187
External contact fuse protection, safety contacts			
in accordance with the standard	EN 60947-5-1	EN 60947-5-1	EN 60947-5-1
Max. melting integral	260 A²s	260 A²s	260 A²s
Blow-out fuse, quick	10 A	10 A	10 A
Blow-out fuse, slow	6 A	6 A	6 A
Blow-out fuse, gG	10 A	10 A	10 A
Circuit breaker 24V AC/DC, characteristic B/C	6 A	6 A	6 A
External contact fuse protection, auxiliary contacts			
Max. melting integral	160 A²s	160 A²s	160 A²s
Blow-out fuse, quick	4 A	4 A	4 A
Blow-out fuse, slow	2 A	2 A	2 A
Blow-out fuse, gG	4 A	4 A	4 A
Circuit breaker, 24 V AC/DC, characteristic B/C	2 A	2 A	2 A
Contact material	AgCuNi + 0,2 µm Au	AgCuNi + 0,2 µm Au	AgCuNi + 0,2 µm Au
Conventional thermal current while loading several contacts	750107	751107	751187
I _{th} per contact at UB DC; AC1: 240 V, DC1: 24 V			
Conv. therm. current with 1 contact	6 A	6 A	6 A
Conv. therm. current with 2 contacts	5,5 A	5,5 A	5,5 A
Conv. therm. current with 3 contacts	4,5 A	4,5 A	4,5 A
Conv. therm. current with 4 contacts	4 A	4 A	4 A
Times	750107	751107	751187
Switch-on delay			
with automatic start after power on typ.	30 ms	30 ms	30 ms
with automatic start after power on max.	50 ms	50 ms	50 ms
Delay-on de-energisation			
with E-STOP typ.	18 ms	18 ms	18 ms
with E-STOP max.	30 ms	30 ms	30 ms
with power failure typ.	18 ms	18 ms	18 ms
with power failure max.	30 ms	30 ms	30 ms
Environmental data	750107	751107	751187
Climatic suitability	EN 60068-2-78	EN 60068-2-78	EN 60068-2-78

Environmental data	750107	751107	751187
Ambient temperature			
Temperature range	-10 - 55 °C	-10 - 55 °C	-10 - 55 °C
Storage temperature			
Temperature range	-40 - 85 °C	-40 - 85 °C	-40 - 85 °C
Climatic suitability			
Humidity	93 % r. h. at 40 °C	93 % r. h. at 40 °C	93 % r. h. at 40 °C
Condensation during operation	Not permitted	Not permitted	Not permitted
EMC	EN 60947-5-1, EN 61000-6-2, EN 61000-6-4, EN 61326-3-1	EN 60947-5-1, EN 61000-6-2, EN 61000-6-4, EN 61326-3-1	EN 60947-5-1, EN 61000-6-2, EN 61000-6-4, EN 61326-3-1
Vibration			
in accordance with the standard	EN 60068-2-6	EN 60068-2-6	EN 60068-2-6
Frequency	10 - 55 Hz	10 - 55 Hz	10 - 55 Hz
Amplitude	0,35 mm	0,35 mm	0,35 mm
Airgap creepage			
in accordance with the standard	EN 60947-1	EN 60947-1	EN 60947-1
Overvoltage category	III	III	III
Pollution degree	2	2	2
Rated insulation voltage	250 V	250 V	250 V
Rated impulse withstand voltage	6 kV	6 kV	6 kV
Protection type			
Housing	IP40	IP40	IP40
Terminals	IP20	IP20	IP20
Mounting area (e.g. control cabinet)	IP54	IP54	IP54
Mechanical data	750107	751107	751187
Mounting position	Any	Any	Any
Mechanical life	10,000,000 cycles	10,000,000 cycles	10,000,000 cycles
Material			
Bottom	PC	PC	PC
Front	PC	PC	PC
Top	PC	PC	PC
Connection type	Screw terminal	Spring-loaded terminal	Spring-loaded terminal
Mounting type	plug-in	plug-in	plug-in

Mechanical data	750107	751107	751187
Conductor cross section with screw terminals			
1 core flexible	0,25 - 2,5 mm², 24 - 12 AWG	–	–
2 core with the same cross section, flexible with crimp connectors, no plastic sleeve	0,25 - 1 mm², 24 - 16 AWG	–	–
2 core with the same cross section, flexible without crimp connectors or with TWIN crimp connectors	0,2 - 1,5 mm², 24 - 16 AWG	–	–
Torque setting with screw terminals	0,5 Nm	–	–
Stripping length with screw terminals	7 mm	–	–
Conductor cross section with spring-loaded terminals: Flexible with/without crimp connector	–	0,2 - 2,5 mm², 24 - 12 AWG	0,2 - 2,5 mm², 24 - 12 AWG
Spring-loaded terminals: Terminal points per connection	–	2	2
Stripping length with spring-loaded terminals	–	9 mm	9 mm
Dimensions			
Height	98 mm	100 mm	100 mm
Width	17,5 mm	17,5 mm	17,5 mm
Depth	120 mm	120 mm	120 mm
Weight	170 g	170 g	170 g

Safety characteristic data



NOTICE

You must comply with the safety characteristic data in order to achieve the required safety level for your plant/machine.

Operating mode	EN ISO 13849-1: 2023	EN ISO 13849-1: 2023	EN IEC 62061 SIL CL/max.	EN IEC 62061 61508	EN/IEC 61511 61508	EN/IEC 61511 61508	EN ISO 13849-1: 2023
	PL	Category	SIL	PFH [1/h]	SIL	PFD	T _M [year]

Safety contacts, instantaneous

PL e	Cat. 4	SIL 3	2,31E-09	SIL 3	2,03E-06	20
-------------	---------------	--------------	-----------------	--------------	-----------------	-----------

Explanatory notes for the safety-related characteristic data:

- ▶ T_M is the maximum mission time in accordance with EN ISO 13849-1. The value also applies as the retest interval in accordance with EN IEC 61508-6 and EN IEC 61511 and as the proof test interval and mission time in accordance with EN IEC 62061.

All the units used within a safety function must be considered when calculating the safety characteristic data.



INFORMATION

A safety function's SIL/PL values are **not** identical to the SIL/PL values of the products used and may differ from these.

Classification according to ZVEI, CB24I

The following tables describe the classes and specific values of the product interface and the classes of interfaces compatible with it. The classification is described in the ZVEI position paper "Classification of Binary 24 V Interfaces - Functional Safety aspects covered by dynamic testing".

Input	
Interfaces	
Drain	
Interface	Module
Class	C0
Source	
Interface	Sensor
Class	C1, C2, C3
Drain parameters	
Max. test pulse duration	2 ms
Min. input resistance	0,3 kOhm
Max. capacitive load	10 nF
Relay outputs	
Interfaces	
Source	
Interface	Module
Class	A
Drain	
Interface	Actuator
Class	A
Source parameters	
Min. switching voltage	12 V
Max. switching voltage	250 V
Min. switching current	0,003 A
Max. switching current	6 A
Potential isolation	Yes

Supplementary data



CAUTION!

It is essential to consider the relay's service life graphs. The relay outputs' safety-related characteristic data is only valid if the values in the service life graphs are met.

The PFH value depends on the switch frequency and the load of the relay output. If the service life graphs are not accessible, the stated PFH value can be used irrespective of the switch frequency and the load, as the PFH value already considers the relay's B10d value as well as the failure rates of the other components.

Service life graph

The service life graphs indicate the number of cycles from which failures due to wear must be expected. The wear is mainly caused by the electrical load; the mechanical load is negligible.

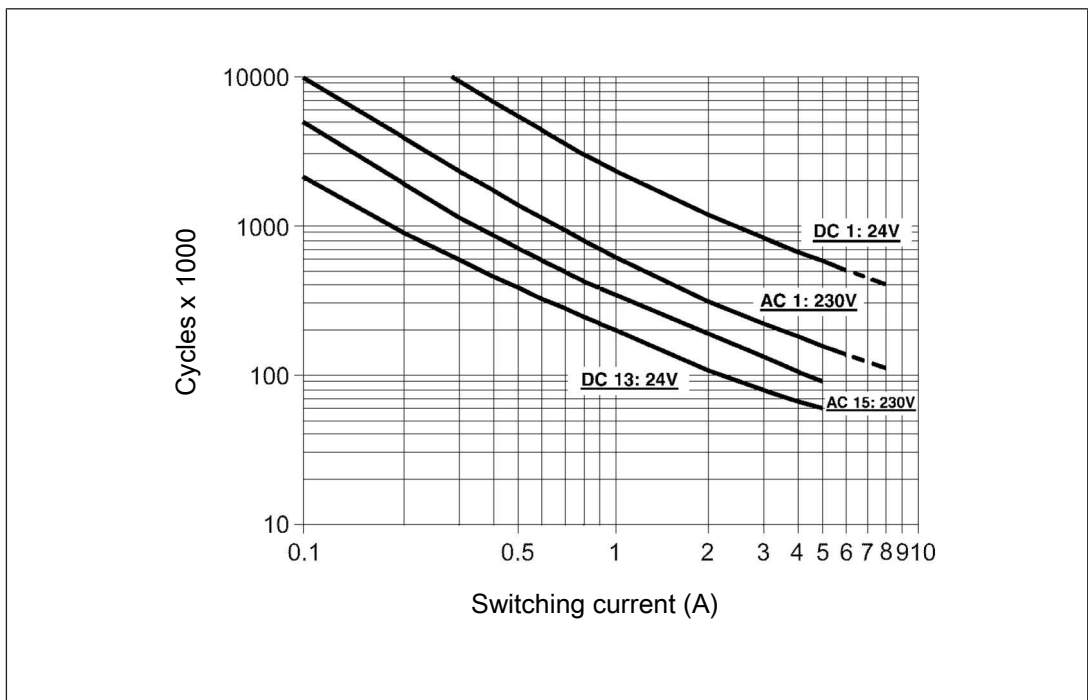

Fig.: Service life graphs at 24 V DC and 230 V AC

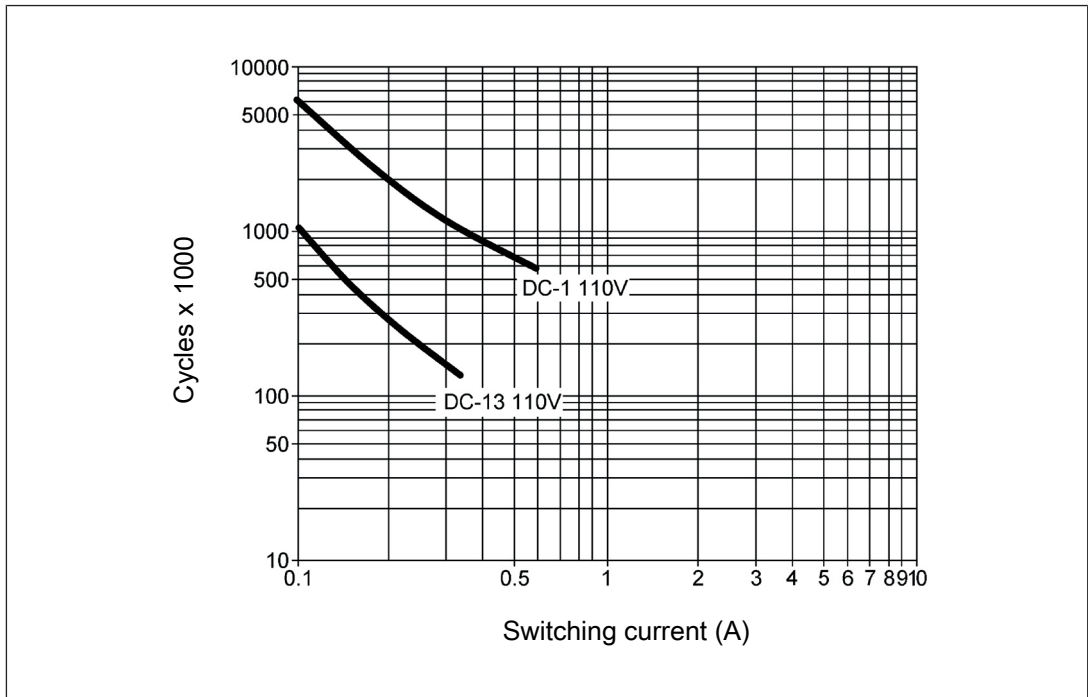

Fig.: Service life graphs at 110 V DC

Example

- ▶ Inductive load: 0.2 A
- ▶ Utilisation category: AC15
- ▶ Contact service life: 2 000 000 cycles

Provided the application to be implemented requires fewer than 2 000 000 cycles, the PFH value (see [Technical details \[15\]](#)) can be used in the calculation.

To increase the service life, sufficient spark suppression must be provided on all output contacts. With capacitive loads, any power surges that occur must be noted. With DC contactors, use flywheel diodes for spark suppression.

Operating height in accordance with EN 60664-1

The values stated in the technical details apply to the use of the product in operating heights up to max. 2000 m above sea level. When used in greater heights, constraints have to be taken into account:

- ▶ Permitted maximum operating height 5000 m
- ▶ Reduction of rated insulation voltage and rated impulse withstand voltage for applications with safe separation:

Maximum operation height	Rated insulation voltage	Overvoltage category	Max. rated impulse withstand voltage
3000 m	150 V	II	2.5 kV
	100 V	III	2.5 kV
4000 m	150 V	II	2.5 kV
	100 V	III	2.5 kV
5000 m	150 V	II	2.5 kV
	100 V	III	2.5 kV

- ▶ Reduction of rated insulation voltage and rated impulse withstand voltage for applications with basic insulation:

Maximum operation height	Rated insulation voltage	Overvoltage category	Max. rated impulse withstand voltage
3000 m	250 V	II	2.5 kV
	150 V	III	2.5 kV
4000 m	250 V	II	2.5 kV
	150 V	III	2.5 kV
5000 m	250 V	II	2.5 kV
	150 V	III	2.5 kV

- ▶ From an operating height of 2000 m the max. permitted ambient temperature is reduced by 0.5 °C/100 m

Operating height	Permitted ambient temperature
3000 m	50 °C
4000 m	45 °C
5000 m	40 °C

Remove plug-in terminals

Procedure

► Insert a suitable screwdriver into the housing recess behind the terminal.

Do **not** remove the terminals by pulling the cables!

► Lever the terminal out.

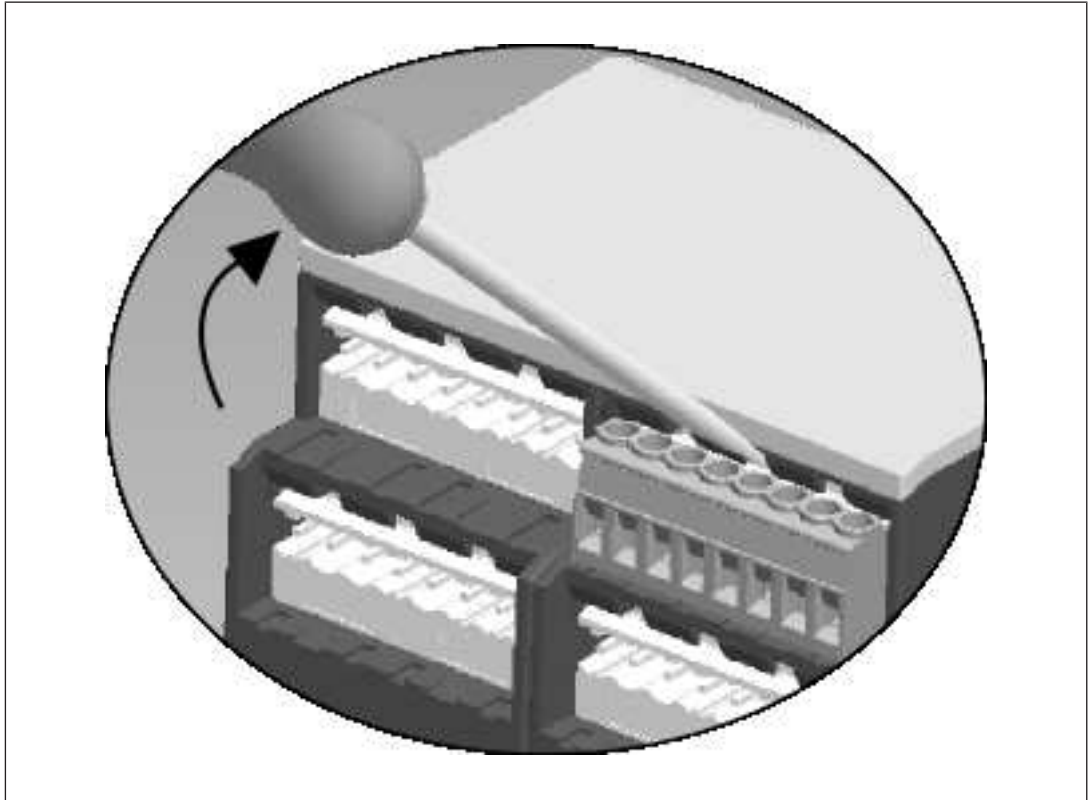

Order reference

Product type	Features	Terminals	Product ID
PNOZ s7	24 VDC	Screw terminals	750107
PNOZ s7 C	24 VDC	Spring-loaded terminals	751107
PNOZ s7 C (coated version)	24 VDC	Spring-loaded terminals	751187

EU/EC declaration of conformity

These products meet the requirements of the directive 2006/42/EC on machinery up to and including 19 January 2027, and the EU regulation 2023/1230 of the European Parliament and of the Council from 20 January 2027. The full EU and EC declaration of conformity is available to download at www.pilz.com/manuals.

Authorised representative: Pilz GmbH & Co. KG, Felix-Wankel-Str. 2, 73760 Ostfildern, Germany

UKCA-Declaration of Conformity

These products comply with following UK legislation: Supply of Machinery (Safety) Regulation 2008.

The complete UKCA Declaration of Conformity is available on the Internet at www.pilz.com/manuals.

Representative: Pilz Automation Technology, Pilz House, Little Colliers Field, Corby, Northamptonshire, NN18 8TJ United Kingdom, eMail: mail@pilz.co.uk

Support

Technical support is available from Pilz round the clock.

Americas

Brazil

+55 11 97569-2804

Canada

+1 888 315 7459

Mexico

+52 55 5572 1300

USA (toll-free)

+1 877-PILZUSA (745-9872)

Asia

China

+86 400-088-3566

Japan

+81 45 471-2281

South Korea

+82 31 778 3390

Australia and Oceania

Australia

+61 3 95600621

New Zealand

+64 9 6345350

Europe

Austria

+43 1 7986263-444

Belgium, Luxembourg

+32 9 3217570

France

+33 3 88104003

Germany

+49 711 3409-444

Ireland

+353 21 4804983

Italy, Malta

+39 0362 1826711

Scandinavia

+45 74436332

Spain

+34 938497433

Switzerland

+41 62 88979-32

The Netherlands

+31 347 320477

Türkiye

+90 216 5775552

United Kingdom

+44 1536 460866

You can reach our international hotline on:

+49 711 3409-222

support@pilz.com

Reporting security vulnerabilities or security incidents

If you would like to report a security vulnerability or a security incident in connection with a Pilz product, please contact our **Pilz Product Security Incident Response Team (PSIRT)**.

You can reach us at: www.pilz.com/psirt

Pilz develops environmentally-friendly products using ecological materials and energy-saving technologies. Offices and production facilities are ecologically designed, environmentally-aware and energy-saving. So Pilz offers sustainability, plus the security of using energy-efficient products and environmentally-friendly solutions.



www.pilz.com/facebook



www.pilz.com/linkedin



www.pilz.com/xing



www.pilz.com/youtube



21399-EN-18, 2026-05 Printed in Germany
© Pilz GmbH & Co. KG, 2024

CECE, CHRE, CMSE®, IndustrialPi®, Leansate®, MYZEL®, PAS4000®, PAScal®, PASconfig®, Pilz®, PIIT®, PMCprimo®, PMCprotego®, PMCTendo®, PMD®, PMM®, PNOZ®, Primo®, PSEN®, PSS®, PVS®, SafetyBUS p®, SafetyNET p®, THE SPIRIT OF SAFETY® are registered and protected trademarks of Pilz GmbH & Co. KG in some countries. We would point out that product features may vary from the details stated in this document, depending on the status at the time of publication and the scope of the equipment. We accept no responsibility for the validity, accuracy and entirety of the text and graphics presented in this information. Please contact our Technical Support if you have any questions.

We are represented internationally. Please refer to our homepage www.pilz.com for further details or contact our headquarters.

Headquarters: Pilz GmbH & Co. KG, Felix-Wankel-Straße 2, 73760 Ostfildern, Germany
Telephone: +49 711 3409-0, E-Mail: info@pilz.com, Internet: www.pilz.com

