



▶ PNOZ m B1

PILZ
THE SPIRIT OF SAFETY

Operating Manual-1003790-EN-09

- Configurable, safe small controllers PNOZmulti 2



This document is a translation of the original document.

Where unavoidable, for reasons of readability, the masculine form has been selected when formulating this document. We do assure you that all persons are regarded without discrimination and on an equal basis.

All rights to this documentation are reserved by Pilz GmbH & Co. KG. Copies may be made for the user's internal purposes. Suggestions and comments for improving this documentation will be gratefully received.

CECE®, CHRE®, CMSE®, INDUSTRIAL PI®, Leansafe®, MYZEL®, PAS4000®, PAS-cal®, PASconfig®, Pilz®, PIT®, PMCprimo®, PMCprotego®, PMctendo®, PMD®, PMI®, PNOZ®, Primo®, PSEN®, PSS®, PVIS®, SafetyBUS p®, SafetyEYE®, SafetyNET p®, THE SPIRIT OF SAFETY® are registered and protected trademarks of Pilz GmbH & Co. KG in some countries.



SD means Secure Digital

1	Introduction	6
1.1	Validity of documentation	6
1.2	Using the documentation	6
1.3	Definition of symbols	6
2	Overview	8
2.1	Range.....	8
2.2	Product features.....	8
2.3	USB memory.....	8
2.4	Front view.....	9
3	Safety and Security	10
3.1	Intended use	10
3.1.1	Product.....	10
3.1.2	Application ranges.....	10
3.1.3	Application conditions	11
3.1.4	Use of qualified personnel.....	11
3.1.5	Prerequisites for operation.....	11
3.1.6	Specific measures for intended use	11
3.1.7	Improper use	12
3.1.8	Security environment	12
3.1.9	Third-party manufacturer licence information.....	12
3.2	System requirements	12
3.3	Safety regulations	12
3.3.1	Safety assessment.....	12
3.3.2	Warranty and liability.....	13
3.3.3	For your safety	13
3.4	General security information	13
3.5	Security measures	16
3.5.1	Implemented security measures	16
3.5.2	Required security measures	16
4	Function description	18
4.1	Integrated protection mechanisms	18
4.2	Functions.....	18
4.3	System reaction time.....	18
4.4	Detection of shorts across contacts	19
4.5	Block diagram	20
4.6	Diagnostics.....	20
4.7	Ethernet interface.....	20
4.8	Device security.....	20
5	Installation	22
5.1	Control cabinet installation.....	22
5.1.1	Mounting distances	23
5.2	Dimensions in mm.....	24
5.3	Connecting the base unit and expansion modules	24

6	Commissioning	26
6.1	General wiring guidelines	26
6.2	Connection	26
6.3	Ethernet interfaces	27
6.3.1	RJ45 interfaces ("Ethernet")	27
6.3.2	Requirements of the connection cable and connector	27
6.3.3	Interface configuration	27
6.3.4	RJ45 connection cable	28
6.4	Use USB memory	29
6.5	Load project from PNOZmulti Configurator	30
6.6	Activate project via the display on the base unit	30
6.7	Display settings	31
6.7.1	Operate menu	31
6.7.2	Displays and settings	31
6.7.2.1	Status indicators	32
6.7.2.2	Project menu	33
6.7.2.3	Device Info menu	35
6.7.2.4	Error Stack menu	36
6.7.2.5	Operating Info menu	36
6.7.2.6	Connections menu	36
6.7.2.7	Ethernet menu	38
6.7.2.8	Time menu	39
6.7.2.9	System mode menu	39
6.7.2.10	User login menu	39
6.8	Function test during commissioning	40
7	Operation	41
7.1	LED indicators	41
7.2	Show error stack on the display	42
8	Factory reset	43
9	Maintenance and testing	44
10	Decommissioning	45
10.1	Disposal	45
11	Technical details	46
11.1	Safety characteristic data	48
12	Network data	49
13	Order reference	50
13.1	Product	50
13.2	Accessories	50
13.2.1	Terminals	50
13.2.2	USB memory	50
13.2.3	Plug-in connector	50

13.2.4	Terminating plug	50
14	EU/EC declaration of conformity	51
15	UKCA-Declaration of Conformity	52

1 Introduction

1.1 Validity of documentation

This documentation is valid for the product PNOZ m B1 from Version HW:01, FW:01.12.

This operating manual explains the function and operation, describes the installation and provides guidelines on how to connect the product.

1.2 Using the documentation

This document is intended for instruction. Only install and commission the product if you have read and understood this document. The document should be retained for future reference.

1.3 Definition of symbols

Information that is particularly important is identified as follows:



DANGER!

This warning must be heeded! It warns of a hazardous situation that poses an immediate threat of serious injury and death and indicates preventive measures that can be taken.



WARNING!

This warning must be heeded! It warns of a hazardous situation that could lead to serious injury and death and indicates preventive measures that can be taken.



CAUTION!

This refers to a hazard that can lead to a less serious or minor injury plus material damage, and also provides information on preventive measures that can be taken.



NOTICE

This describes a situation in which the product or devices could be damaged and also provides information on preventive measures that can be taken. It also highlights areas within the text that are of particular importance.



INFORMATION

This gives advice on applications and provides information on special features.

2 Overview

2.1 Range

- ▶ Base unit PNOZ m B1
- ▶ Terminator
- ▶ USB memory

2.2 Product features

Application of the product PNOZ m B1:

Base unit of the configurable control system PNOZmulti 2

The product has the following features:

- ▶ Can be configured in the PNOZmulti Configurator
- ▶ Support for module programs
- ▶ 4 test pulse outputs to detect shorts between the inputs
- ▶ Backlit display for:
 - Status information
 - Device information
 - Diagnostics
 - Activate project
 - Ethernet settings
 - System's date and time
 - Stop and start device
- ▶ Multifunction switch for menu control
- ▶ Ethernet interface with switch
- ▶ LED indicator for:
 - Operating status
 - Error messages
 - Diagnostics
 - Supply voltage
- ▶ Plug-in connection terminals:
Either spring-loaded terminal or screw terminal available as an accessory (see Order references for accessories).
- ▶ Expansion modules can be connected
(please refer to the document "PNOZmulti System Expansion" for details of the type and number that can be connected)

2.3 USB memory

To save and transfer projects you need the Pilz USB memory that is supplied with the device.

2.4 Front view

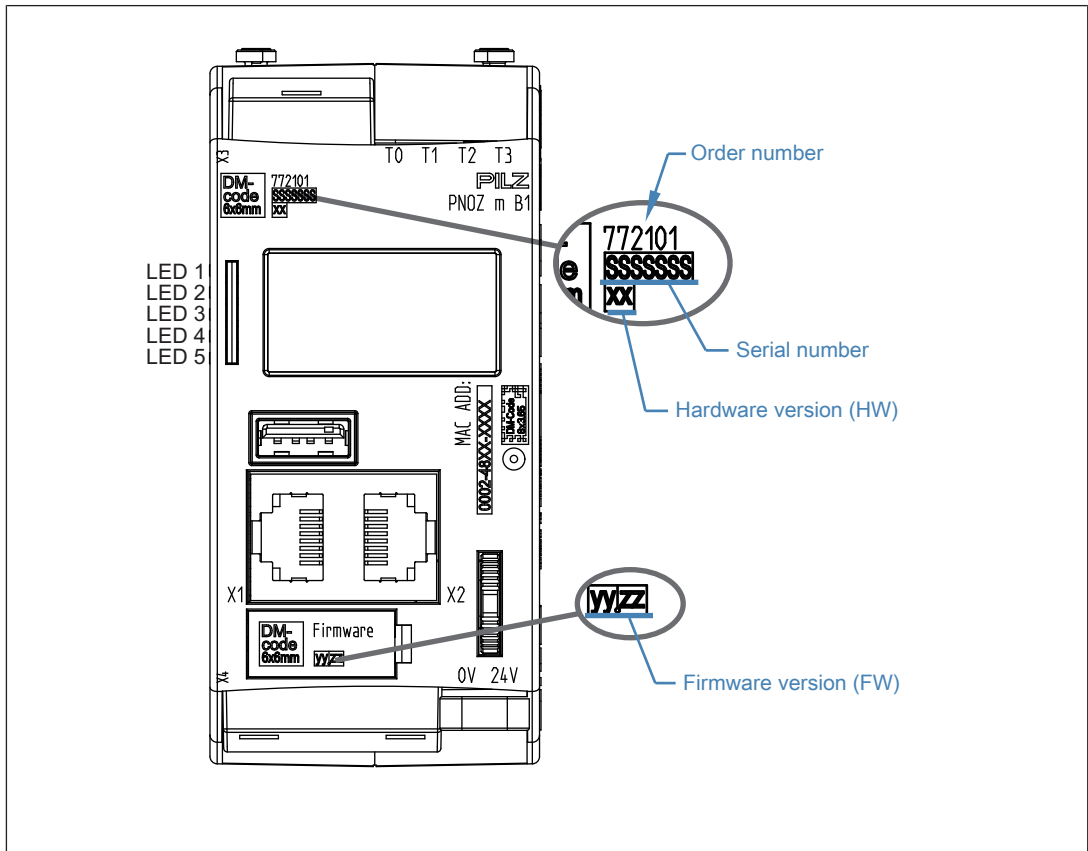

Legend

- X1/X2: Ethernet interface
- X3: Test pulse outputs T0 - T3
- X4: Labelling clip for firmware version
- LED 1: Supply voltage
- LED 2: FS (Initialise/Run/Stop)
- LED 3: ST (Initialise/Run/Stop)
- LED 4: Diag (Project reset/Identify project)
- LED 5: FAULT (IFault/OFault)

To determine the version of the device, please note:

The firmware version number is on the labelling clip. This is also the version number that must be selected in the PNOZmulti Configurator under **Version** during the hardware configuration.

3 Safety and Security

3.1 Intended use

3.1.1 Product

The product PNOZ m B1 is a base unit in the configurable system PNOZmulti 2. The configurable system PNOZmulti 2 is used for the safety-related interruption of safety circuits.

3.1.2 Application ranges

The configurable system PNOZmulti 2 is designed for use on:

- ▶ Emergency stop equipment
- ▶ Safety circuits in accordance with VDE 0113 Part 1 and EN 60204-1

Lifts Directive

The product can be used as a PESSRAL (programmable electronic system in safety-related applications for lifts) in accordance with the Lifts Directive 2014/33/EU. It meets the requirements for passenger and goods lifts in accordance with EN 81-1/2, EN 81-20, EN 81-22 and EN 81-50, as well as the requirements for escalators and moving walks in accordance with EN 115-1.

The safety controller should be installed in a protected environment that meets at least the requirements of pollution degree 2.

Example: a protected indoor space or control cabinet with a protection type of IP54 and appropriate climate control.

Use in furnaces

The product PNOZ m B1 can be used in furnaces in accordance with EN 298.

Please note:

- ▶ To protect against transient power failures (EN 61000-4-11) the AC power supply used for the system must meet a secondary buffering for 20 ms.
- ▶ If the system is used in a DC network, sufficient surge voltage protection must be ensured.
To limit surge voltage, use external protection elements with the following minimum properties:
Installation class 4 / test level 4 in accordance with EN 61000-4-5 (4kV 1.2/50 µs)

3.1.3 Application conditions



NOTICE

EMC-compliant electrical installation

The product is designed for use in an industrial environment. The product may cause interference if installed in other environments. If installed in other environments, measures should be taken to comply with the applicable standards and directives for the respective installation site with regard to interference.



CAUTION!

Inputs and outputs for standard functions must not be used for safety-related applications.

3.1.4 Use of qualified personnel

The products may only be assembled, installed, programmed, commissioned, operated, de-commissioned and maintained by persons who are competent to do so.

A competent person is a qualified and knowledgeable person who, because of their training, experience and current professional activity, has the specialist knowledge required. In order to inspect, assess and handle products, devices, systems, plant and machinery, this person must be familiar with the state of the art and the applicable national, European and international laws, directives and standards.

It is the company's responsibility only to employ personnel who

- ▶ Are familiar with the basic regulations concerning health and safety / accident prevention,
- ▶ Have read and understood the section on "Safety" in this description and
- ▶ Have a good knowledge of the generic and specialist standards applicable to the specific application.

3.1.5 Prerequisites for operation

This document is intended for instruction. Only install and commission the product if you have read and understood this document.

Only approved accessories and approved consumables may be used.

3.1.6 Specific measures for intended use



NOTICE

The safety functions should be checked after initial commissioning and each time the plant/machine is changed. The safety functions may only be checked by qualified personnel.

3.1.7 Improper use

The following is deemed improper use in particular:

- ▶ Any component, technical or electrical modification to the product,
- ▶ Use of the product outside the areas described in this operating manual,
- ▶ Use of the product outside the technical details (see chapter entitled [Technical Details](#) [ 46]).



3.1.8 Security environment

The product must be located in an environment in which physical access to the product and data cables is adequately prevented by mechanical and organisational measures. For example, this can be achieved by installing the product in a lockable control cabinet or in a sufficiently secure machine enclosure.

If the product is operated outside a machine enclosure or control cabinet or if wired communication connections run outside, organisational measures must be taken to ensure that only authorised personnel have physical access to the product. This can be achieved, for example, by controlling access to the workshop.

The use of a firewall or other suitable means must ensure that there can be no unauthorised access to the machine network.

If insecure network protocols such as HTTP, TCP/IP, Modbus/TCP are used to communicate with the machine, a VPN tunnel or comparable technology must be used to ensure the integrity and confidentiality of the data.

Further information on Security can be found under [General security information](#) [ 16] and [Security measures](#) [ 16].

3.1.9 Third-party manufacturer licence information

This product includes Open Source software with various licenses.

Further information is available in the document "Third-party manufacturer licence information PNOZ m B1" (document number 1006230) at www.pilz.com.

3.2 System requirements

Please refer to the "Product Modifications" document in the "Version overview" section for details of which versions of the PNOZmulti Configurator can be used for this product.

3.3 Safety regulations

3.3.1 Safety assessment

Before using the product, a risk assessment is required in accordance with the Machinery Regulation.

Connecting additional units may result in further risks. Take the necessary measures to protect against corruption.

The product as an individual component fulfils the functional safety requirements in accordance with EN/IEC 61508, EN ISO 13849-1/2 and EN IEC 62061. However, this does not guarantee the functional safety of the overall plant/machine. To achieve the relevant safety level of the overall plant/machine's required safety functions, each safety function needs to be considered separately.

It is the responsibility of the user/operator to carry out a risk assessment for their application, in which they consider the impact of assumed errors in the wiring and take appropriate measures to control or avoid these errors.

3.3.2 Warranty and liability

All claims to warranty and liability will be rendered invalid if

- ▶ The product was used contrary to the purpose for which it is intended,
- ▶ Damage can be attributed to not having followed the guidelines in the manual,
- ▶ Operating personnel are not suitably qualified,
- ▶ Any type of modification has been made (e.g. exchanging components on the PCB boards, soldering work etc.).

3.3.3 For your safety

The unit meets all the necessary conditions for safe operation. However, you should always ensure that the following safety requirements are met:

- ▶ This operating manual only describes the basic functions of the unit. Advanced functions are described in the online help for the PNOZmulti Configurator, in the "PNOZmulti Communication Interfaces" document and in "PNOZmulti Special Applications". Only use these functions once you have read and understood the documentation.
- ▶ Please note the "PNOZmulti Installation Manual".
- ▶ You must note the information stated in the "PNOZmulti Safety Manual".
- ▶ Adequate protection circuit must be provided for all inductive consumers.
- ▶ Do not open the housing or make any unauthorised modifications.
- ▶ Please make sure you shut down the supply voltage when performing maintenance work (e.g. exchanging contactors).

3.4 General security information

The term "security" refers to information security in plants, systems, machines and networks. This includes protection from external attacks (remote access) as well as protection from attacks from insiders. Measures are taken that protect the integrity and confidentiality of sensitive data and guarantee plant/machine availability. So all measures that concern the integrity, availability, confidentiality and authenticity of data fall under the term "security" (see also the IEC 62443 series of standards).

Planning and implementation

Securing plants, systems, machines and networks against cyberthreats requires a holistic industrial security concept that is state of the art and is continuously developed further. All plants, systems, machinery and networks that require protecting must be assessed individually. The assessment must take into account organisational as well as technical meas-

ures. If necessary, seek advice from Pilz Customer Support.

Planning and implementation should be carried out in accordance with a defined security process. For example, your security process should take the following into account:

- ▶ Note the regulatory specifications and requirements from the locally applicable safety and application standards with regard to protection from manipulation.
- ▶ Perform a risk analysis (e.g. in accordance with IEC 62443-3-2) and then plan the resulting security measures carefully.
- ▶ Where possible, counter the security risks using a multi-layered concept (e.g. defence-in-depth concept).
- ▶ Name the necessary security measures and document them.
- ▶ Check the security measures after implementation.
- ▶ Carry out a new risk analysis after every change and adapt the security measures if necessary.
- ▶ It is advisable to review the security measures regularly, for example annually.

Defence-in-depth concept

In accordance with IEC 62443-4-1, the defence-in-depth concept is an approach in which multiple layers of independent security methods are used.

The defence-in-depth concept is based on the following rationale:

- ▶ Every protective measure can be overcome, and probably will be overcome.
- ▶ A multi-layer structure (e.g. onion model) implements several concerted and coordinated measures.
- ▶ Due to independent defence mechanisms in each layer, successful exploitation of a weakness in one layer is prevented, or made more difficult, by a measure in another layer.
- ▶ Generally with the defence-in-depth concept, an attack is made more difficult because the attacker has to circumvent different, independent security measures, one after the other.

The standard series IEC 62443 distinguishes between the following three areas of responsibility:

- ▶ Manufacturer
- ▶ System integrator
- ▶ Operator

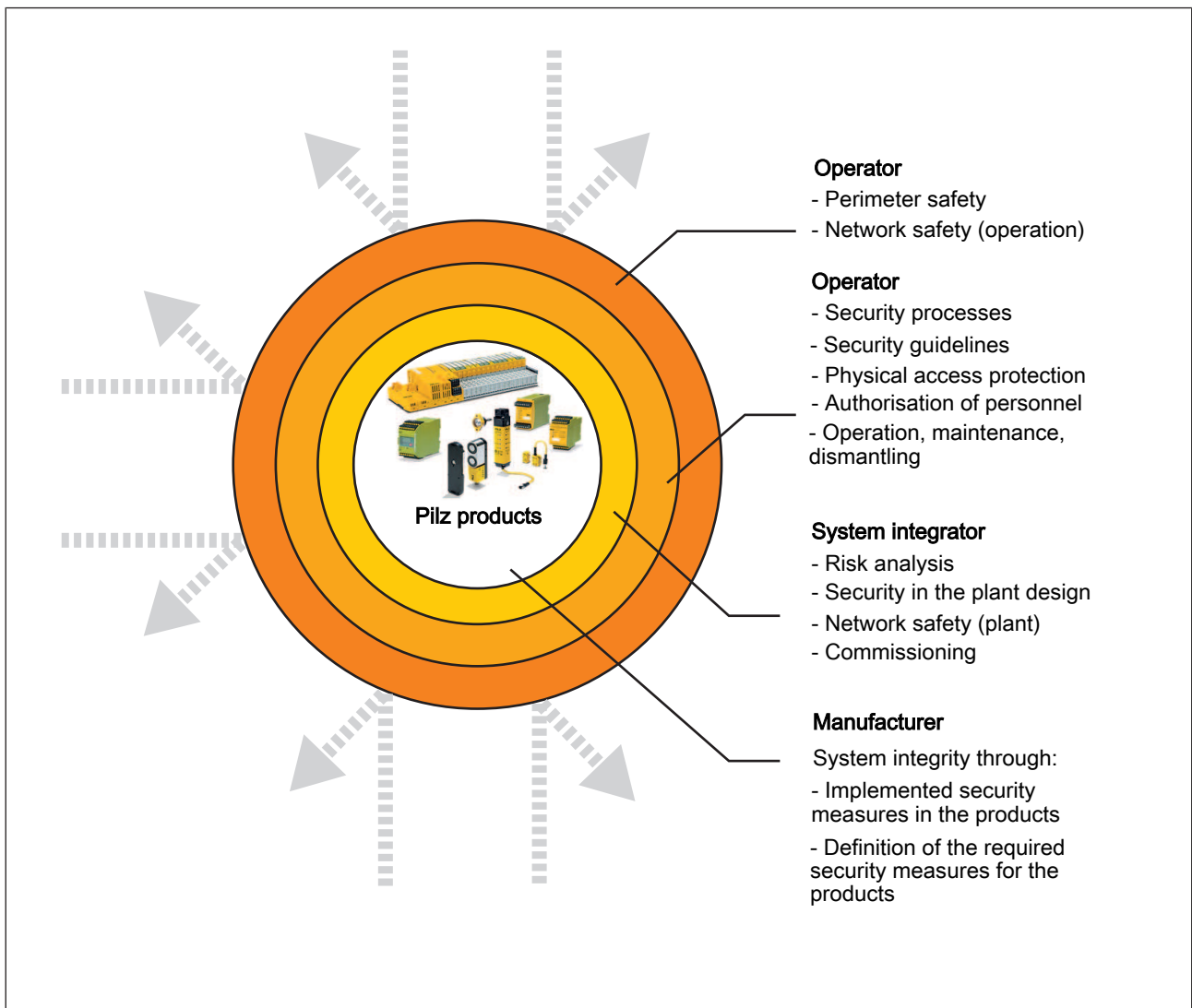

Fig.: Roles and responsibilities in the defence-in-depth onion model

Security incident management

Should the product have a security vulnerability, this will be published in a security advisory. You'll find the security advisories under www.pilz.com/security. You can also report any security problems there.

Implemented and required security measures

The section below describes the implemented and required security measures. To protect the Pilz devices and system solutions and the data/projects created using the Pilz tools from cyber threats, it is essential that you use the implemented security measures and implement the required security measures.

3.5 Security measures

3.5.1 Implemented security measures

User management PNOZmulti Configurator

- ▶ The product is protected against unauthorised access through authentication with user name and password.
- ▶ Permission groups (roles) restrict the scope of permissions for individual users to perform specific online functions.
- ▶ During an authenticated online session, the network data traffic between the PNOZmulti Configurator and the device is protected by integrity protection and encryption.
- ▶ The online session is automatically ended if the connection is terminated.

Password protection for device display

- ▶ Access to settings on the device display can be password-protected.
- ▶ The session will end automatically if there is no input on the display for 5 minutes.

Passwords

- ▶ Passwords are stored in the device in encrypted form.
- ▶ Passwords for online functions can be changed by the user.
- ▶ The administrator can use a password policy to define minimum criteria for passwords in order to prevent users from creating weak passwords.

Logging

- ▶ Changes to the project configuration are saved in the event list and error stack.
- ▶ An administrator's changes to the user configuration are saved in the error stack under "Security".
- ▶ Users' changes to passwords or user names are saved in the error stack under "Security".
- ▶ A factory reset is saved in the event list and error stack.

3.5.2 Required security measures

Password protection

- ▶ On delivery, the "admin" user is configured with the default password. Change the password to prevent unauthorised access.
- ▶ On delivery, permissions for anonymous users are active. Deactivate permissions for anonymous users if they are not absolutely necessary, in order to prevent unauthorised access without authentication.
- ▶ Password protection is not active for the device display upon delivery. Assign a password and activate display constraints to prevent unauthorised access.
- ▶ No password policy is defined upon delivery. Define a password policy during commissioning to prevent users from creating weak passwords when changing their password.

Physical manipulation

- ▶ The product is not protected against physical manipulation. We would therefore recommend that the product is installed in a lockable control cabinet or in a sufficiently secure machine enclosure.

If the product is operated outside a machine enclosure or control cabinet or if wired communication connections run outside, organisational measures must be taken to ensure that only authorised personnel have physical access to the product. This could be implemented, for example, by controlling access to the workshop.

Storage media

The project configuration data is stored on the USB memory and can be accessed without authorisation. To prevent unauthorised access to sensitive project data, restrict access to the device.

Network in general

- ▶ Make sure that the device is in a closed, secured network.
- ▶ Protect the product from unauthorised data exchange via the network by using a firewall or providing other appropriate measures. Only allow the data exchange that's required for the application. Any data exchange that is not required for the application must be prevented by the firewall.

Network protocols

- ▶ Modbus/TCP is intended for data exchange between devices within the machine. Restrict the connections to the machine's internal network. Secure the connections against external networks.

- Virtual inputs can be changed without authorisation via Modbus/TCP.
- With a configured Safe Ethernet connection 2, unauthorised access to the assigned Modbus registers can lead to the safety function being switched off.

- ▶ The proprietary log (TCP/IP Port 9000) for data exchange with other devices within the machine must be protected against unauthorised access by deactivating the anonymous permission "Process data exchange".

If it is still necessary to exchange data with other devices, suitable measures must be taken to restrict access from outside the secure network, e.g. through suitable rules in the firewall and whitelisting.

Please note that the same endpoint (TCP/IP Port 9000) is required for the connection between the PNOZmulti Configurator and the device.

- Virtual inputs can be changed without authorisation via the proprietary log (TCP/IP port 9000).
- Process data and any log data can be accessed without authorisation via the proprietary log (TCP/IP port 9000).

4 Function description

4.1 Integrated protection mechanisms

The relay meets the following safety requirements:

- ▶ The circuit is redundant with built-in self-monitoring.
- ▶ The safety device remains effective in the case of a component failure.

4.2 Functions

The function of the inputs and outputs on the control system depends on the safety circuit created using the PNOZmulti Configurator. A USB memory stick is used to download the safety circuit to the base unit. The base unit has 2 microcontrollers that monitor each other. They evaluate the input circuits on the base unit and expansion modules and switch the outputs on the expansion modules accordingly.

The LEDs on the base unit and expansion modules indicate the status of the configurable control system PNOZmulti.

The online help on the PNOZmulti Configurator contains descriptions of the operating modes and all the functions of the control system, plus connection examples.

4.3 System reaction time

Calculation of the maximum reaction time between an input switching off and a linked output in the system switching off is described in the document "PNOZmulti System Expansion".

4.4 Detection of shorts across contacts

4 test pulse outputs that use different test pulses (test pulse 0 (T0) ... test pulse 3 (T3)) are available for detecting shorts between the inputs.

Shorts between inputs are detected if the inputs are connected to different test pulses (test pulse 0 ... test pulse 3).

Pulsing of test pulse outputs T0 ... T3 (typical times):

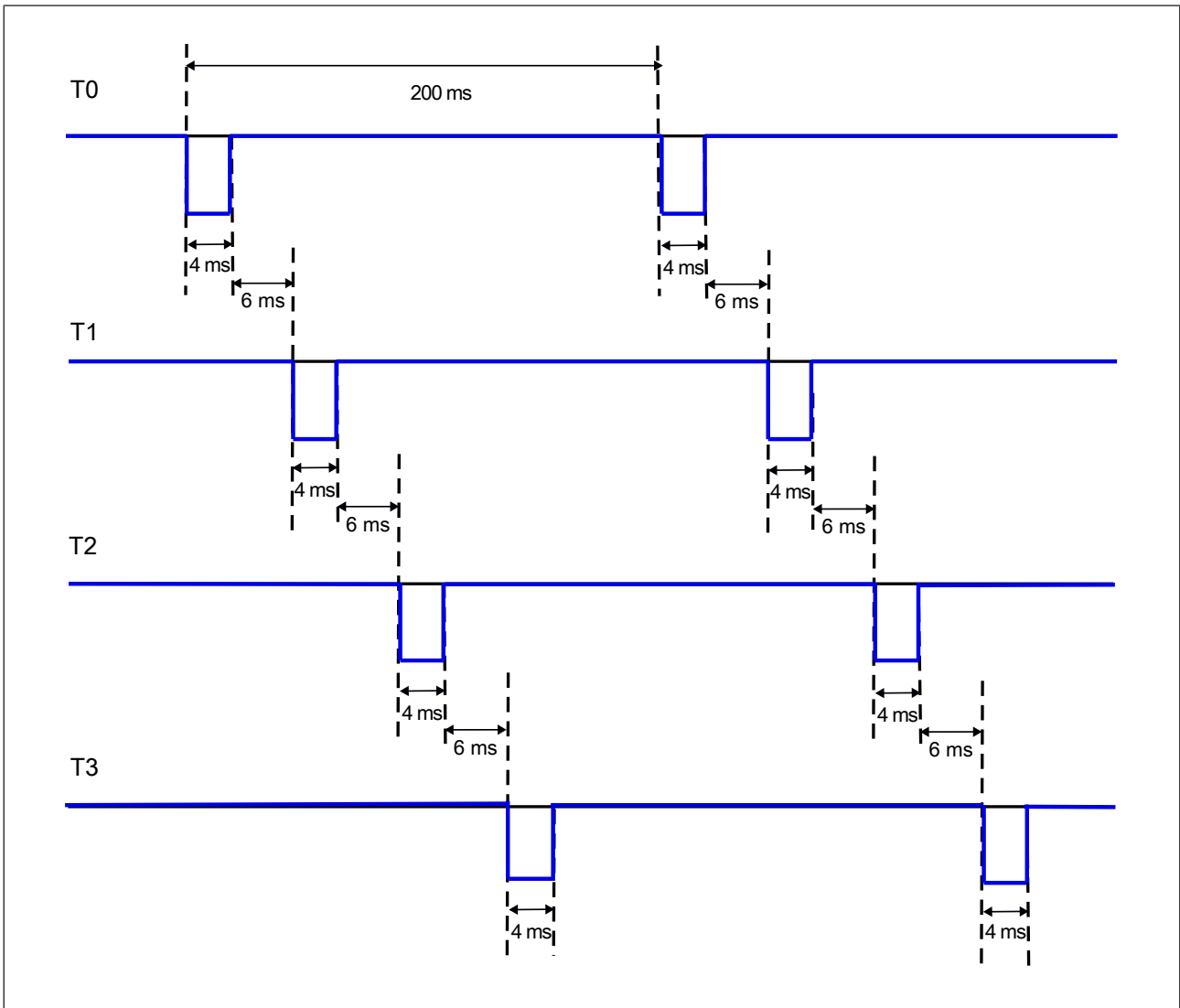

4.5 Block diagram

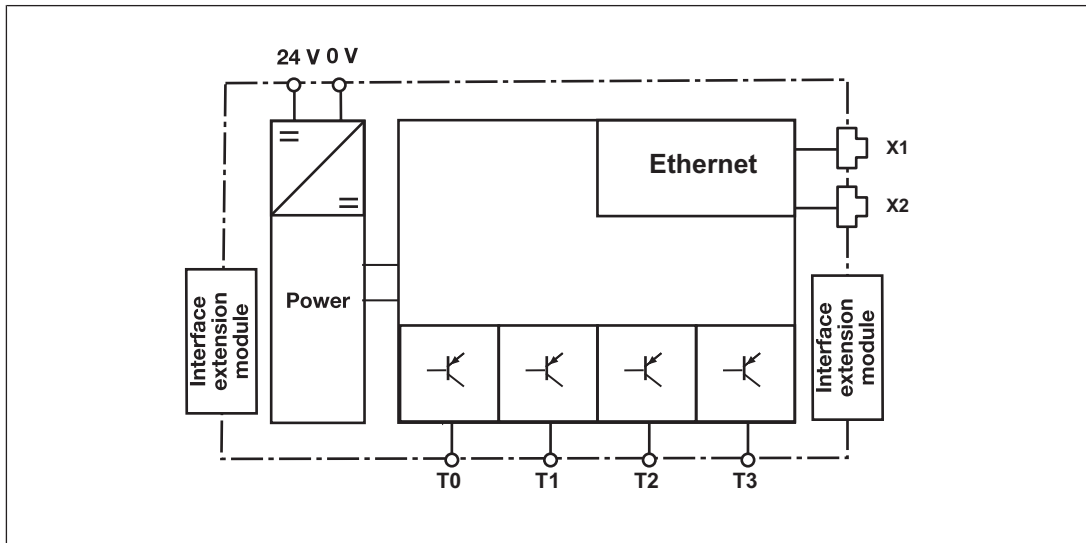

4.6 Diagnostics

The status and error messages displayed by the LEDs are saved in an error stack. This error stack can be shown on the display or can be read from the PNOZmulti Configurator via the Ethernet interface. More comprehensive diagnostics are possible via the interfaces or via one of the fieldbus modules. For more information refer to the document ***PNOZmulti 2 Communication Interfaces*** and the ***Online Help for the PNOZmulti Configurator***.

4.7 Ethernet interface

The product PNOZ m B1 has an Ethernet interface to

- ▶ Manage and download projects
- ▶ Read the diagnostic data
- ▶ Set virtual inputs for standard functions
- ▶ Read virtual outputs for standard functions.

Information on diagnostics via the interfaces can be found in the document ***PNOZmulti Communication Interfaces***.

The connection to Ethernet is made via the two 8-pin RJ45 sockets.

The Ethernet interface is configured via the menu in the display (see chapter entitled Displays and settings) or in the PNOZmulti Configurator (see ***Online Help for the PNOZmulti Configurator***).

4.8 Device security

User management

The base unit PNOZ m B1 can be protected from unauthorised access via user management.

In order to access the device or perform specific actions via the PNOZmulti Configurator, users must use their credentials to authenticate themselves.

A user account can be created for each user in the PNOZmulti Configurator user management.

There are user groups that have pre-defined permissions.

A user group is assigned to each user account.

Each user account obtains a unique user name and a password.

When you log into a new device for the first time or after a factory reset has been performed, use the factory-set default credentials to log in as administrator:

Login name	admin
Password	pilz

As administrator you have every permission. Change the default password immediately after logging in for the first time.

User management is configured in the PNOZmulti Configurator and transferred to the device.

Detailed information on user management and how it is configured can be found in the online help for the PNOZmulti Configurator.

Password for device display

Password protection for access to actions in the device display can be configured for the base unit PNOZ m B1 in the PNOZmulti Configurator.

Certain actions can only be performed when users authenticate themselves with the appropriate password in the device's display menu.



NOTICE

Please note that user management and password protection for the device display must be reconfigured after a device is exchanged.

5 Installation

5.1 Control cabinet installation

- ▶ The unit should be installed in a control cabinet with a protection type of at least IP54.
- ▶ Install the system vertically on to a horizontal mounting rail. The venting slots must face upward and downward. Other mounting positions could damage the safety system.
- ▶ Use the locking elements on the rear of the unit to attach it to a mounting rail.
- ▶ In environments exposed to heavy vibration, the unit should be secured using a fixing element (e.g. retaining bracket or end angle).
- ▶ Open the locking slide before lifting the unit from the mounting rail.
- ▶ To comply with EMC requirements, the mounting rail must have a low impedance connection to the control cabinet housing.



NOTICE

Damage due to electrostatic discharge!

Electrostatic discharge can damage components. Ensure against discharge before touching the product, e.g. by touching an earthed, conductive surface or by wearing an earthed armband.

5.1.1 Mounting distances

With control cabinet installation it is essential to maintain a certain distance from the top and bottom, as well as to other heat-producing devices (see diagram). The values stated for the mounting distances are minimum specifications.

The ambient temperature in the control cabinet must not exceed the figure stated in the technical details. Air conditioning may otherwise be required.

Mounting distances:

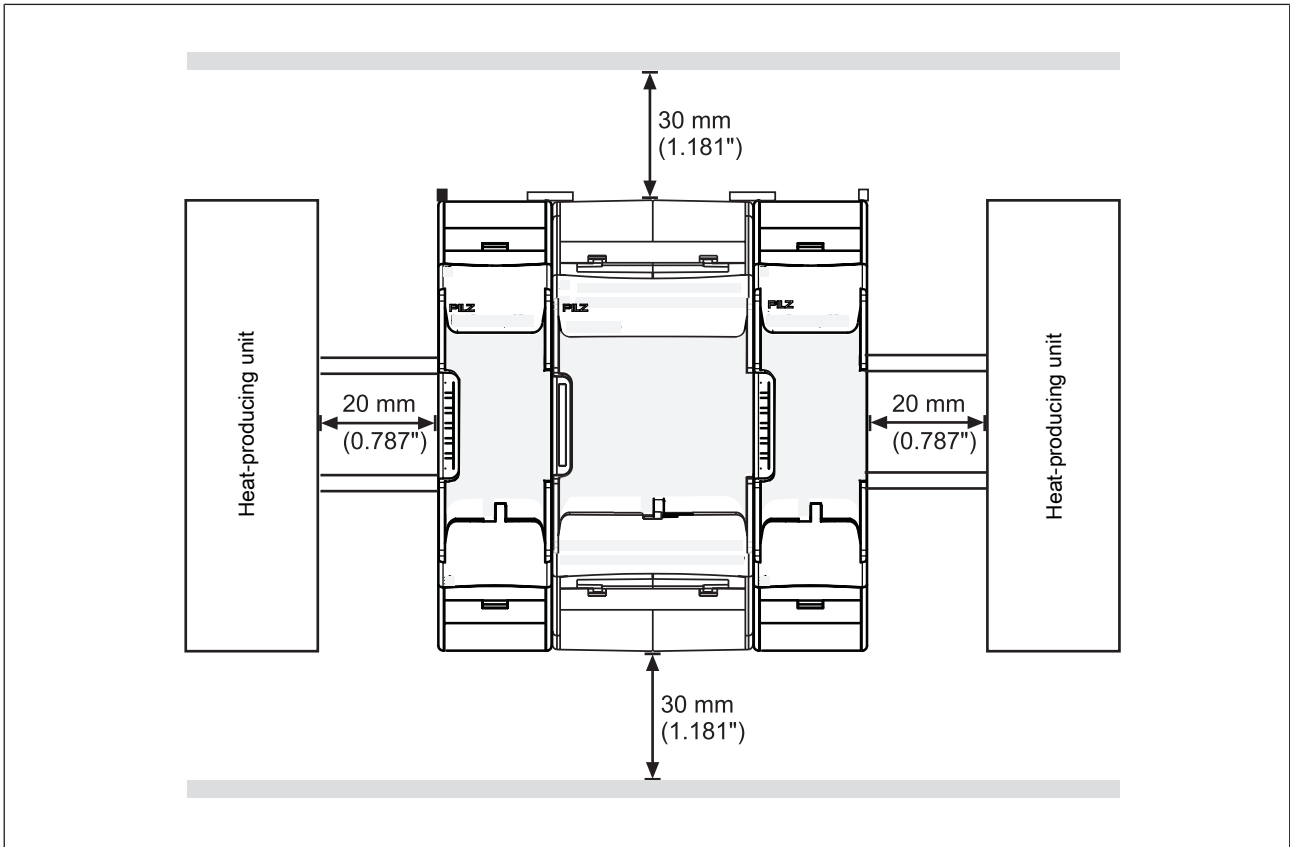

5.2 Dimensions in mm

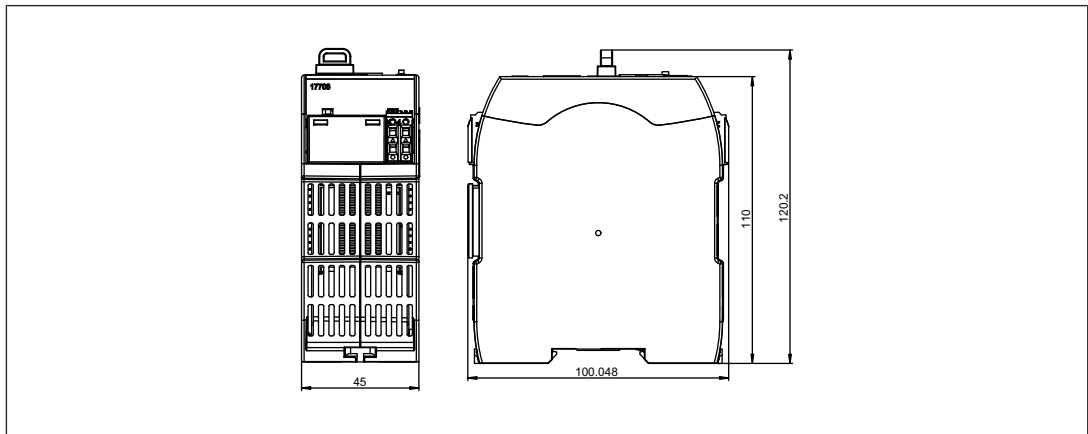

5.3 Connecting the base unit and expansion modules

The position of the expansion modules is defined in the PNOZmulti Configurator. The expansion modules are connected to the left or right of the base unit, depending on the type.

Please refer to the document "PNOZmulti System Expansion" for details of the number of modules that can be connected to the base unit and the module types.



CAUTION!

Please note:

Only connect the expansion modules on the slot stated in the document "System expansion", otherwise the expansion module may be destroyed as a result.

The modules are linked via jumpers.

- ▶ Remove the terminator on the side of the base unit.
- ▶ Install the base unit and expansion modules on the mounting rail in the order configured in the PNOZmulti Configurator and connect the units using the jumper supplied.
- ▶ Fit the terminator to the unconnected interfaces on the base unit and expansion module.

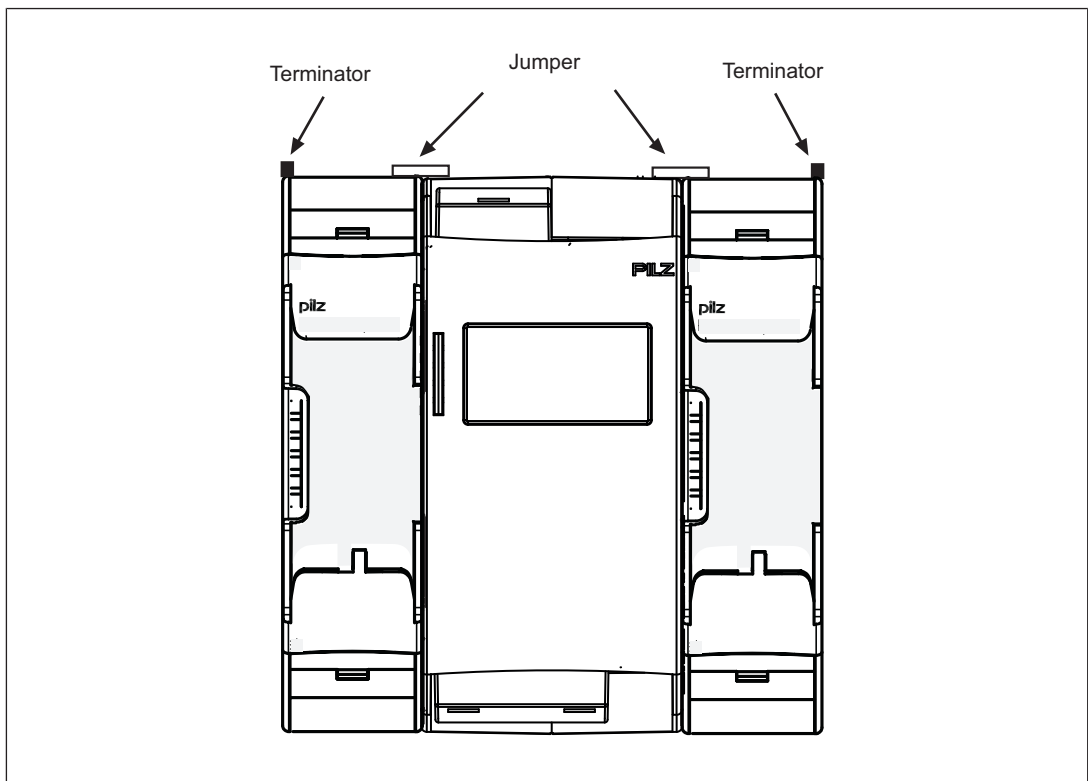

CAUTION!

Only connect the base unit and expansion modules when the supply voltage is switched off.

6 Commissioning

6.1 General wiring guidelines

The wiring is defined in the circuit diagram in the Configurator. There you can select the inputs that are to perform a safety function and the outputs that are to switch this safety function.

Please note:

- ▶ Information given in the [Technical details \[46\]](#) must be followed.
- ▶ Use copper wiring with a temperature stability of 75 °C.
- ▶ Adequate protection circuit must be provided on all output contacts with inductive loads.
- ▶ The safety system and input circuits must always be supplied by a single power supply. The power supply must meet the regulations for extra low voltages with protective separation (SELV, PELV).
- ▶ Test pulse outputs are used to detect shorts between the inputs. Shorts between inputs are detected if the inputs are connected to different test pulses (test pulse 0 ... test pulse 3). Shorts between inputs of the same module with the same test pulses will not be detected.
- ▶ Test pulse outputs must exclusively be used to activate the inputs. They must not be used to drive loads.
Do not route the test pulse lines together with actuator cables within an unprotected multicore cable.
- ▶ The maximum permitted total current of the test pulse outputs is 640 mA.

6.2 Connection

Procedure:

- ▶ Connect the supply voltage for the control system:
 - Terminal 24 V: + 24 VDC
 - Terminal 0 V: 0 V
- ▶ Protect the supply voltage as follows:
 - Circuit breaker, characteristic C - 6 A
 - or
 - Blow-out fuse, slow, 6 A



CAUTION!

Do not connect or disconnect expansion modules and terminators during operation.

6.3 Ethernet interfaces

6.3.1 RJ45 interfaces ("Ethernet")

Two free switch ports are provided as Ethernet interfaces via an internal autosensing switch. The autosensing switch automatically detects whether data transfer is occurring at 10 Mbit/s or 100 Mbit/s.



INFORMATION

The connected subscribers must support the autosensing/autonegotiation function. If not, the communication partner must be set permanently to "10 Mbit/s, half duplex".

The switch's automatic crossover function means there is no need to distinguish on the connection cable between patch cable (uncrossed data line connection) and crossover cable (crossover data line connection). The switch automatically creates the correct data line connection internally. Patch cable can therefore be used as the connection cable for end devices as well as cascading.

Both Ethernet interfaces use RJ45 technology.

6.3.2 Requirements of the connection cable and connector

The following minimum requirements must be met:

- ▶ Ethernet standards (min. Category 5) 10BaseT or 100BaseTX
- ▶ Double-shielded twisted pair cable for industrial Ethernet use
- ▶ Shielded RJ45 connectors (industrial connectors)

6.3.3 Interface configuration

RJ45 socket 8-pin	PIN	Standard	Crossover
	1	TD+ (Transmit+)	RD+ (Receive+)
	2	TD- (Transmit-)	RD- (Receive-)
	3	RD+ (Receive+)	TD+ (Transmit+)
	4	n.c.	n.c.
	5	n.c.	n.c.
	6	RD- (Receive-)	TD- (Transmit-)
	7	n.c.	n.c.
	8	n.c.	n.c.

6.3.4 RJ45 connection cable

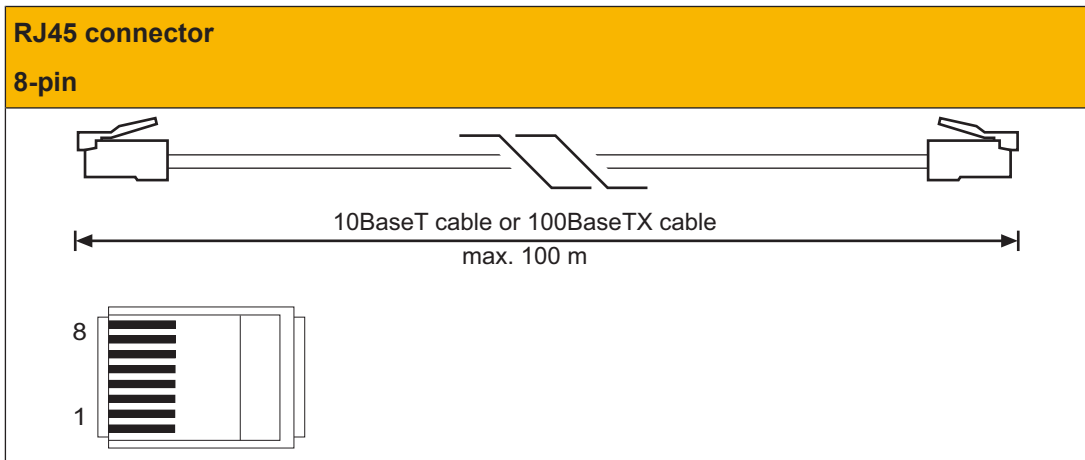

NOTICE

With the plug-in connection please note that the data cable and connector have a limited mechanical load capacity. Appropriate design measures should be used to ensure that the plug-in connection is insensitive to increased mechanical stress (e.g. through shock, vibration). Such measures include fixed routing with strain relief, for example.

6.4 Use USB memory

Multiple projects can be stored on the USB memory supplied. One of these can be activated and executed on the base unit.

Please note the following when using the USB memory:

- ▶ The USB memory must always be plugged in during operation.
- ▶ In order to copy projects, for example, the USB memory can be removed and plugged into the PC or into another base unit PNOZ m B1.
- ▶ Only Pilz USB memories may be used!

Use USB memory

- ▶ Carefully remove the USB memory from the holder on the bottom of the device.

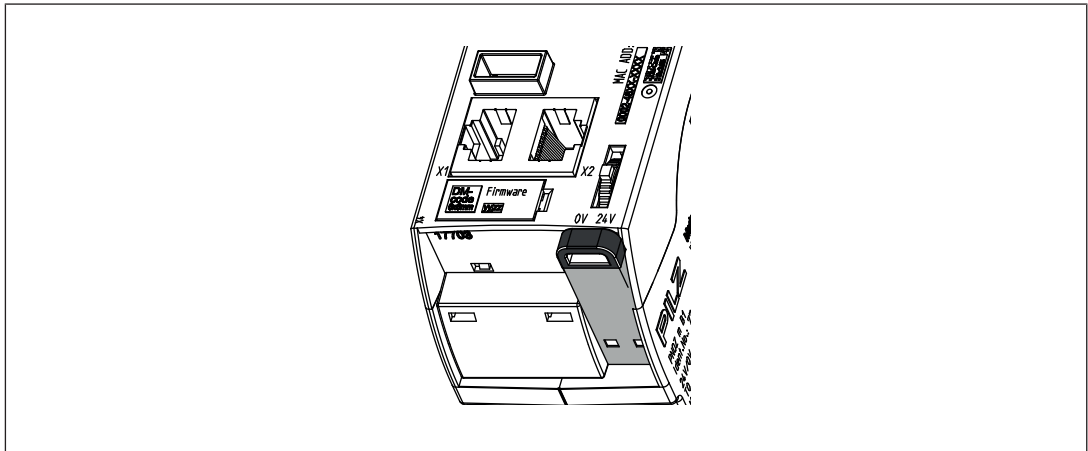

- ▶ Apply light pressure to insert the USB memory into the slot. Take care not to tilt the USB memory. It should be easy to insert.
- ▶ Insert the USB memory into the slot, only as far as the end of the metal housing. The plastic handle must not be inserted

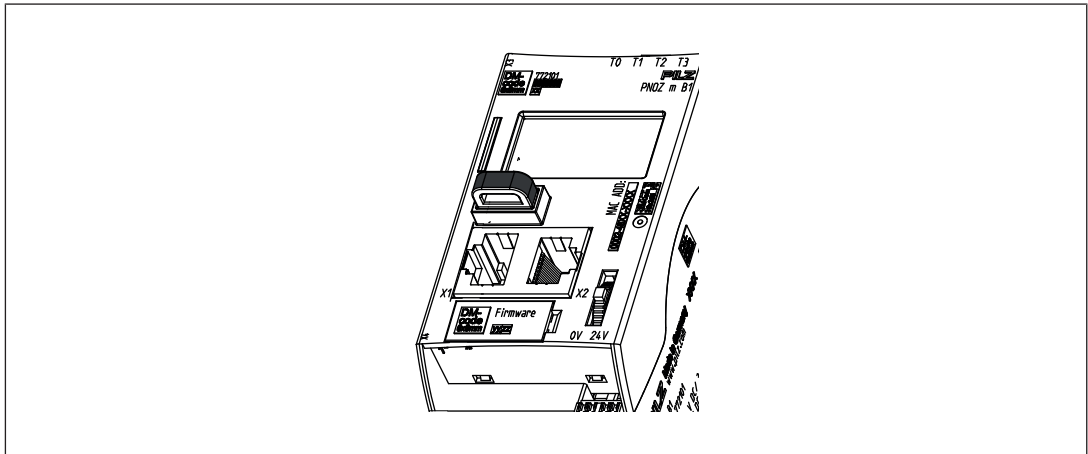

Remove USB memory

- ▶ Due to mechanical requirements, the USB memory is inserted tightly within the device and so may be difficult to remove.

In this case use an appropriate tool, such as a screwdriver for example, and carefully extract the USB memory (see diagram).

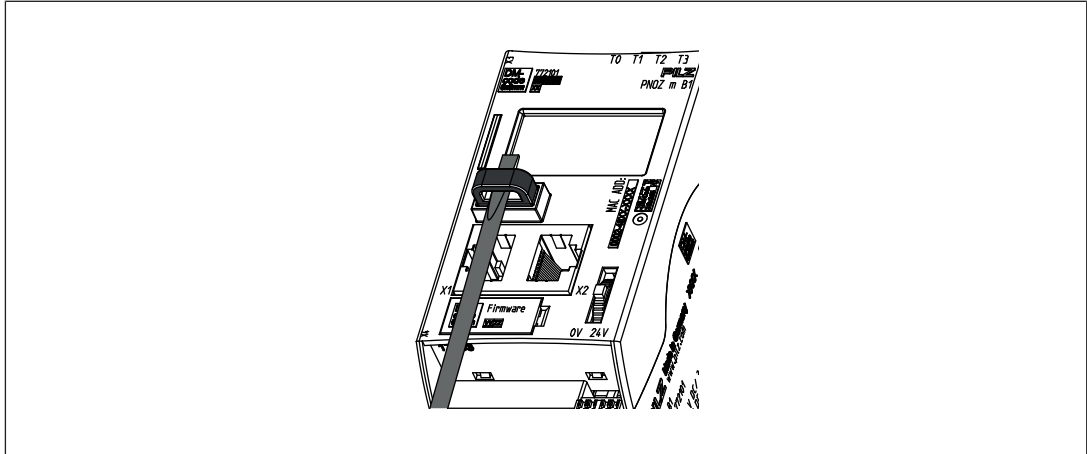

6.5 Load project from PNOZmulti Configurator

Projects can be transferred from the PNOZmulti Configurator to the USB memory. Several projects may be stored on the USB memory, A project can be activated directly. This can be performed in the Project Manager of the PNOZmulti Configurator (see online help for the PNOZmulti Configurator).

Procedure:

- ▶ Connect the computer containing the PNOZmulti Configurator to the base unit PNOZ m B1 via the Ethernet interface.
- ▶ Make sure that the USB memory is plugged into the base unit PNOZ m B1.
- ▶ Switch on the supply voltage.
- ▶ Transfer the required project to the USB memory and activate it on the base unit via the Project Manager on the PNOZmulti Configurator, as described in the online help for the PNOZmulti Configurator.
- ▶ As the project is loaded, the base unit must be stopped and then restarted.
- ▶ Once the project has been loaded successfully and the device has been restarted, the status of the supply voltage is shown on the display. The "RUN" LED is lit.

6.6 Activate project via the display on the base unit

A project that is stored on the USB memory can be activated in the base unit via settings on the display.

Procedure:

- ▶ Make sure that the USB memory containing the current project is plugged into the base unit PNOZ m B1.
- ▶ Switch on the supply voltage.

- ▶ Stop the device via the multifunction switch on the display via the menu setting **System mode** -> **Stop system** (for details of how to navigate the display see the section entitled [Display settings \[31\]](#))
- ▶ In the **Project** menu, navigate to the folder containing the required project and select the project file with the extension **.mpnoz2**.
- ▶ Load the project by pressing the multifunction switch and restart via the menu setting **System mode** -> **Restart system**.

6.7 Display settings

Various settings can be made and information displayed via the menu on the device's display.

6.7.1 Operate menu

The menu settings are made on the device's display via a multifunction switch. You can switch between the menu levels by pressing or turning the multifunction switch.

Press multifunction switch



- ▶ Confirm selection/setting
- ▶ Switch to sub-menu
- ▶ Exit menu: \..

Move multifunction switch up or down



- ▶ Select menu

6.7.2 Displays and settings

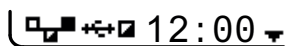

The LC display has five lines. Information is shown on the display and settings can be made.

The field at the top right of the display shows information about the connection and instructions for the menu settings:







Legend:

- Network connection/traffic
- USB memory inserted
- 12:00** System time
- Processing of the menu is blocked. A login via the **User Login** is required for processing.

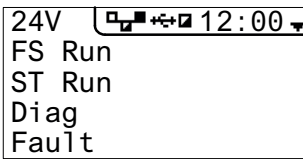
- ← Press the multifunction switch to go back to the higher level menu.
- Press the multifunction switch to access the sub-menu.
- 4 Hold the multifunction switch down for 4 s to confirm the selection or perform the action.
- i Press the multifunction switch to obtain information.
-  Press the multifunction switch to call up the system message.
-  Press the multifunction switch to call up the user message.

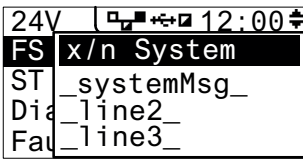
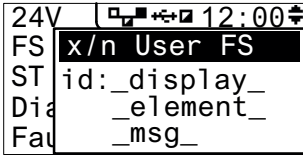

6.7.2.1 Status indicators

Display	Display	Description
Permanent display		LED display ▶ A warning symbol shows that a message is present, which can be called up
		
System / User... System or display messages	 	 System message is present or  User message is present (user-specific messages that are created in the PNOZmulti Configurator)

6.7.2.2 Project menu

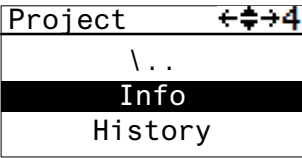
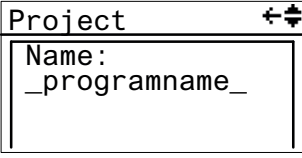
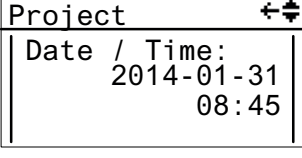
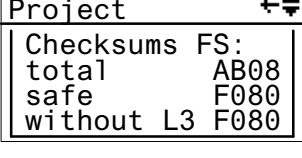
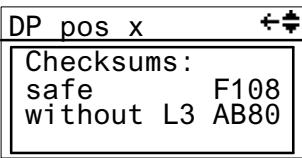
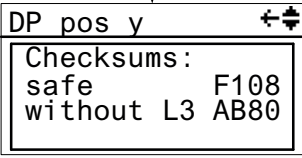
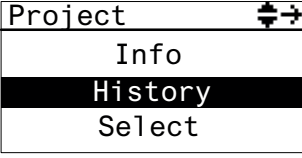
In the **Project** menu you can display information about the project that is activated on the device. You can also activate a different project from the USB memory on the device. See also [Activate project via the display on the base unit](#) [📖 30] and reset the project on the device.

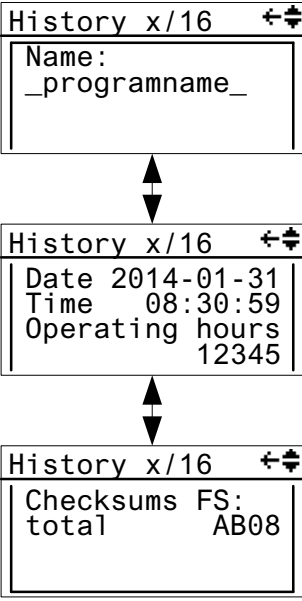
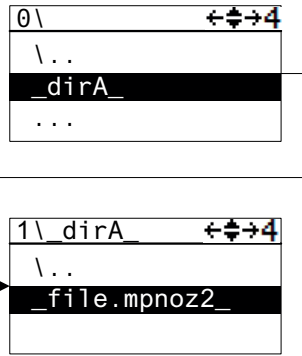
Display	Display	Description
Info:		Information is displayed about the project activated on the device
Name Project name		Name of project
Date / Time Creation data and time		Date and time that the project was created
Checksums FS Overall check sum and check sums of main program		Display of check sums: ▶ Overall project check sum ▶ Check sum safe of main program ▶ Check sum safe of main program without level 3
Checksums DP pos x Check sums of module program	 	Display of check sums of module program ▶ Check sum safe ▶ Check sum safe without level 3
History: Project history		Project information is displayed for one of the last 16 projects activated

Display	Display	Description
<p>Name Date / Time Checksum FS Checksum DP pos x ...</p>		<p>Display of project information for a selected project</p>
<p>Select: Activate project</p>		<p>Select project contained in the USB memory and activate it on the base unit</p> <ul style="list-style-type: none"> ▶ Prerequisite: Device must be stopped ▶ Hold down multifunction switch for 4 s in order to activate the project
<p>Reset: Reset or update project.</p>		<p>After a reset, the active project is reloaded from the USB memory</p> <ul style="list-style-type: none"> ▶ Prerequisite: Device must be stopped ▶ Hold down multifunction switch for 4 s in order to reset

6.7.2.3 Device Info menu

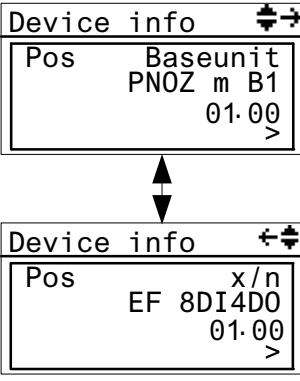
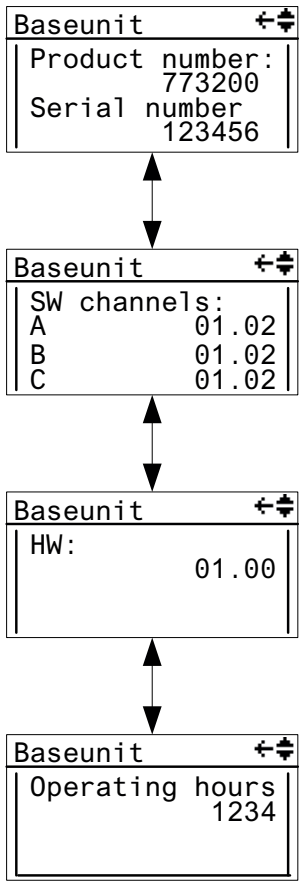
Display	Example	Description
<p>Device Info</p>		<p>Information on the base unit and expansion modules. Overview:</p> <ul style="list-style-type: none"> ▶ Position/slot ▶ Device type ▶ Firmware version
<p>Device information for module</p>		<p>Show device information for a selected module:</p> <ul style="list-style-type: none"> ▶ Order number ▶ Serial number ▶ Software versions ▶ Hardware version ▶ Operating hours

6.7.2.4 Error Stack menu

Display	Example	Description
Error Stack		<p>Display of entries in the error stack (see also section entitled Show error stack on the display [42])</p> <p>To read the error stack entries, please refer to the document PNOZmulti Error Messages</p>

6.7.2.5 Operating Info menu

Display	Example	Description
Operating Info		<p>Display of specific operating parameters for the base unit and expansion modules.</p> <p>e.g.: cycle time, operating temperature, frequencies</p>

6.7.2.6 Connections menu

The connections to the PNOZmulti can be displayed in the **Connections** menu.

Display	Example	Description
Conn. x/n		<p>Information on the connected device:</p> <ul style="list-style-type: none"> ▶ Device ▶ IP address ▶ Connection status: <ul style="list-style-type: none"> – Connected: Connected – Connecting: Establishing the connection – Failed: Connection failed – Error: Error in the connection

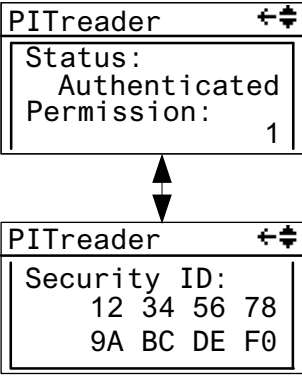
Display	Example	Description
<p>PITreader</p>		<p>Status information about the PITreader:</p> <ul style="list-style-type: none"> ▶ Status: <ul style="list-style-type: none"> – Authenticated: <ul style="list-style-type: none"> The PITreader recognised the transponder key. Permission exists – No key <ul style="list-style-type: none"> No transponder key is inserted in the PITreader – No permission <ul style="list-style-type: none"> The transponder key has no permission (permission = 0) – Auth. failed <ul style="list-style-type: none"> Authentication has failed. The data from the PITreader is invalid – Not ready <ul style="list-style-type: none"> The connection to the PITreader is interrupted. ▶ Permission: <ul style="list-style-type: none"> Permission 1... 64 of the transponder key <p>Security-ID: Security identifier for the transponder key</p>

6.7.2.7 Ethernet menu

The Ethernet configuration can be displayed and changed in the **Ethernet** menu.

Display	Example	Description
Info		Display of the current Ethernet configuration
Change		Change Ethernet configuration...
Edit IP Change IP address		<ul style="list-style-type: none"> ▶ IP address ▶ Subnet mask ▶ Gateway Adjust -> Hold down multifunction switch for 2 s in order to access change mode
Edit Ports Change IP address		Adjust PG port and scan port -> Hold down multifunction switch for 2 s in order to access change mode
Use DHCP Change IP address		Obtain IP address automatically from the network (prerequisite: Network has a DHCP Server utility) -> Hold down multifunction switch for 2 s in order to perform the action

Display	Example	Description
Use Program Change IP address		Load Ethernet settings from the active PNOZmulti project -> Hold down multifunction switch for 2 s in order to perform the action
Use default Change IP address		Load default settings IP address: 169.254.60.1 Subnet mask: 255.255.0.0 Gateway: 0.0.0.0 -> Hold down multifunction switch for 2 s in order to perform the action

6.7.2.8 Time menu

Display	Example	Description
Time Show date and time		Show system's date and time
Set time Set date and time		Change date and time -> Hold down multifunction switch for 2 s in order to access change mode

6.7.2.9 System mode menu

Display	Example	Description
Access		Stop system Restart system -> Hold down multifunction switch for 4 s in order to perform the action

6.7.2.10 User login menu

Display	Example	Description
Password		Enter password to gain access to certain actions in the device display

6.8 Function test during commissioning



CAUTION!

It is essential to check that the safety devices operate correctly

- After exchanging the USB memory
- After activating a project
- When the project was reset and reloaded from the USB memory following a restart (**Reset Project** menu).

7 Operation

Prerequisites

- ▶ The product is configured and a project is saved.
- ▶ The product is installed and wired correctly.
- ▶ You have read the chapter on Safety and Security and complied with the requirements.
- ▶ You have checked that the safety device is functioning correctly

Procedure



Switch on the supply voltage.

When the supply voltage is switched on, the PNOZmulti 2 system loads the active project from the USB memory.













7.1 LED indicators

The control system PNOZmulti is ready for operation when the **24 V**, **FS Run** and **ST Run** LEDs on the base unit are lit continuously.

Legend

-  LED on
-  LED flashes
-  LED off

The LEDs on the base unit change their label depending on the operating status

LEDs												Description	
24 V	FS			ST			Diag			Fault			
	FS Initialize	FS Run	FS Stop	ST Initialize	ST Run	ST Stop	Program Reset	Identify	Diag	IFAULT	OFAULT		Fault
													Supply voltage is present
													Reset project: the active project was deleted by the base unit.
													The base unit is identified via the PNOZmulti Configurator
													FS program is started
													ST program is started
													FS program is executed
													ST program is executed

LEDs												Description	
24 V	FS			ST			Diag			Fault			
	FS Initialize	FS Run	FS Stop	ST Initialize	ST Run	ST Stop	Program Reset	Identify	Diag	IFault	OFAult		Fault
			●										FS program in STOP condition
						●							ST program in STOP condition
		●											Error in FS program
					●								Error in ST program
		●											System error in FS program
					●								System error in ST program
													Recoverable error by user in FS mode
													Recoverable error by user in ST mode

7.2 Show error stack on the display

The error stack can be read from the PNOZmulti Configurator or shown on the LC display. The error stack can store up to 64 status and error messages.

The following information is shown on the LC display:

- ▶ Sequential number of an error stack entry. A new error stack entry is stored in first place.
- ▶ Error class (EC)
- ▶ Error number (EN)
- ▶ Error parameter (EP)

Procedure for showing the error stack on the display, see section entitled Error Stack menu.

To evaluate the entries on the display please read the document **PNOZmulti Error Messages**.

8 Factory reset

A factory reset of the device is always sensible or indeed necessary when the device is removed from the existing plant/machine, possibly to re-use it in another application.

During a factory reset, all the data stored in the device is reset:

- ▶ Project data is deleted from the internal memory.
- ▶ USB memory is deleted and formatted when a USB memory is inserted.
- ▶ Error stack is deleted.
- ▶ Program change log is deleted.
- ▶ Configured user data (user name, passwords, permissions) is deleted and is reset to the default values.

You can initiate a factory reset both in the PNOZmulti Configurator (see online help for the PNOZmulti Configurator) and also directly on the device.

Initiate factory reset directly on the device

- ▶ Switch off the supply voltage to the base unit.
- ▶ Press the multifunction switch, keep it held down and switch the base unit's supply voltage back on.
- ▶ Keep the multifunction switch held down until the display of the PILZ logo disappears.
- ▶ Select **Factory reset** from the main menu.
- ▶ Select **Yes** and hold down the multifunction switch for 2 s.
- ▶ The factory reset has been completed successfully when the status **Factory reset ok** is displayed and the **Diag** LED flashes.



INFORMATION

After switching on the supply voltage, the **Factory reset** menu is only available for 60 s.

If a factory reset is not requested during this time, then **Factory reset** is removed from the menu.

9 Maintenance and testing

It is not necessary to perform maintenance work on the product in normal operation.

- ▶ Please return any faulty product to Pilz.

10 Decommissioning

- ▶ Carry out a factory reset.
- ▶ Delete or destroy the USB memory before disposing of the product.

10.1 Disposal

- ▶ In safety-related applications, please comply with the mission time T_M stated in the safety-related characteristic data.
- ▶ When decommissioning, please comply with local regulations regarding the disposal of electronic devices (e.g. Electrical and Electronic Equipment Act).

11 Technical details

Where standards are undated, the 2026-01 valid editions apply.

General	
Certifications	CE, EAC, KOSHA, TÜV, UKCA, cULus Listed
Application range	Failsafe
Electrical data	
Supply voltage	
for	Supply to the system
Voltage	24 V
Kind	DC
Voltage tolerance	-20 %/+25 %
Output of external power supply (DC)	18,5 W
Output of external power supply (DC) at no load	3 W
Max. power dissipation of module	4,5 W
Status indicator	Display, LED
Test pulse outputs	
Number of test pulse outputs	4
Voltage	24 V
Current	0,32 A
Max. duration of off time during self test	4 ms
Short circuit-proof	Yes
Potential isolation	No
Ethernet interface	
Quantity	2
IP address (automatically off)	169.254.60.1
Connection type	RJ45
Transmission rate	10 MBit/s, 100 MBit/s
Times	
Simultaneity in the two-hand circuit	0,5 s
Processing time	30 ms
Environmental data	
Ambient temperature	
in accordance with the standard	EN 60068-2-14
Temperature range	0 - 60 °C
Forced convection in control cabinet off	55 °C
Storage temperature	
in accordance with the standard	EN 60068-2-1/-2
Temperature range	-25 - 70 °C
Climatic suitability	
in accordance with the standard	EN 60068-2-30, EN 60068-2-78
Humidity	93 % r. h. at 40 °C
Condensation during operation	Not permitted

Environmental data	
Max. operating height above SL	2000 m
EMC	EN 61131-2
Vibration	
in accordance with the standard	EN 60068-2-6
Frequency	5 - 150 Hz
Acceleration	1g
Shock stress	
in accordance with the standard	EN 60068-2-27
Duration	11 ms
Airgap creepage	
in accordance with the standard	EN 61131-2
Overvoltage category	II
Pollution degree	2
Protection type	
in accordance with the standard	EN 60529
Housing	IP20
Terminals	IP20
Mounting area (e.g. control cabinet)	IP54
Mechanical data	
Mounting position	horizontally on mounting rail
DIN rail	
Top hat rail	35 x 15 EN/IEC 60715, 35 x 7,5 EN/IEC 60715
Recess width	27 mm
Cable length	
Sum of individual cable lengths at the test pulse output	2 km
Material	
Bottom	PC
Front	PC
Top	PC
Connection type	Cage clamp terminal, screw terminal
Mounting type	plug-in
Conductor cross section with screw terminals	
1 core flexible	0,25 - 2,5 mm², 24 - 12 AWG
2 core with the same cross section, flexible without crimp connectors or with TWIN crimp connectors	0,2 - 1,5 mm², 24 - 16 AWG
Torque setting with screw terminals	0,5 Nm
Conductor cross section with spring-loaded terminals: Flexible with/without crimp connector	0,2 - 2,5 mm², 24 - 12 AWG
Spring-loaded terminals: Terminal points per connection	2
Stripping length with spring-loaded terminals	9 mm

Mechanical data

Dimensions

Height	101,4 mm
Width	45 mm
Depth	120,2 mm

Weight	209 g
--------	-------

Year of manufacture

The year of manufacture is specified on the product after the reference YOM (Year of Manufacturing).

11.1 Safety characteristic data



NOTICE

You must comply with the safety characteristic data in order to achieve the required safety level for your plant/machine.

Operating mode	EN ISO 13849-1: 2023	EN ISO 13849-1: 2023	EN IEC 62061 SIL CL/max.	EN IEC 62061 61508	EN/IEC 61511 61508	EN/IEC 61511 61508	EN ISO 13849-1: 2023
	PL	Category	SIL	PFH [1/h]	SIL	PFD	T _M [year]
2-channel	PL e	Cat. 4	SIL 3	4,19E-10	SIL 3	3,65E-05	20
Safe Ethernet Connection 2	PL e	Cat. 4	SIL 3	4,85E-11	SIL 3	–	20

Explanatory notes for the safety-related characteristic data:

- ▶ T_M is the maximum mission time in accordance with EN ISO 13849-1. The value also applies as the retest interval in accordance with EN IEC 61508-6 and EN IEC 61511 and as the proof test interval and mission time in accordance with EN IEC 62061.

All the units used within a safety function must be considered when calculating the safety characteristic data.



INFORMATION

A safety function's SIL/PL values are **not** identical to the SIL/PL values of the products used and may differ from these.

12 Network data

Protocol	Direction *	Transport protocol	Port no.	Can be deactivated	Time-critical	Description
Proprietary	In	TCP	9000	Yes	No	PNOZmulti Configurator Online connection
HTTP	In	TCP	80	No	No	PNOZmulti Configurator Transfer of project data
Proprietary	In	UDP	10000	Yes	No	PILZ Device Network Scan
Modbus/Tcp	In	TCP	502	No	No	PNOZmulti Modbus/TCP slave (server)
Modbus/Tcp	Out	TCP	auto	No	No	PILZ PITreader connection

[*]

in: The communication partner starts communication with the product.

out: The product starts communication with the communication partner.

13 Order reference

13.1 Product

Product type	Features	Order no.
PNOZ m B1	Configurable safe small controllers PNOZmulti Mini base unit, expandable, Ethernet interface with switch, USB memory.	772101

13.2 Accessories

13.2.1 Terminals

Product type	Features	Order no.
Set4 Screw Terminals	Set of plug-in screw terminals for PNOZ m B1, base unit, small controllers PNOZmulti2.	750016
Set4 Spring Terminals	Set of spring-loaded terminals for PNOZ m B1, base unit, small controllers PNOZmulti 2.	751016

13.2.2 USB memory

Product type	Features	Order no.
USB Memory 512MB	USB memory, 512 MB, for PNOZ m B1, base unit PNOZmulti 2.	779213

13.2.3 Plug-in connector

Product type	Features	Order no.
RJ45 Connector	RJ45 plug-in connector, straight, IP20, 8-pin, Cat6a, IDC connection, AWG22, cable diameter: 5.5 - 8.5 mm	380401

13.2.4 Terminating plug

Product type	Features	Order no.
PNOZ mm0.xp terminator left (10 pcs.)	Terminator on the left-hand side of the base unit PNOZmulti, yellow/black (10 pieces).	779261

14 EU/EC declaration of conformity

These products meet the requirements of the directive 2006/42/EC on machinery up to and including 19 January 2027, and the EU regulation 2023/1230 of the European Parliament and of the Council from 20 January 2027. The full EU and EC declaration of conformity is available to download at www.pilz.com/manuals.

Authorised representative: Pilz GmbH & Co. KG, Felix-Wankel-Str. 2, 73760 Ostfildern, Germany

15 UKCA-Declaration of Conformity

These products comply with following UK legislation: Supply of Machinery (Safety) Regulation 2008.

The complete UKCA Declaration of Conformity is available on the Internet at www.pilz.com/manuals.

Representative: Pilz Automation Technology, Pilz House, Little Colliers Field, Corby, Northamptonshire, NN18 8TJ United Kingdom, eMail: mail@pilz.co.uk

Support

Technical support is available from Pilz round the clock.

Americas

Brazil

+55 11 97569-2804

Canada

+1 888 315 7459

Mexico

+52 55 5572 1300

USA (toll-free)

+1 877-PILZUSA (745-9872)

Asia

China

+86 400-088-3566

Japan

+81 45 471-2281

South Korea

+82 31 778 3390

Australia and Oceania

Australia

+61 3 95600621

New Zealand

+64 9 6345350

Europe

Austria

+43 1 7986263-444

Belgium, Luxembourg

+32 9 3217570

France

+33 3 88104003

Germany

+49 711 3409-444

Ireland

+353 21 4804983

Italy, Malta

+39 0362 1826711

Scandinavia

+45 74436332

Spain

+34 938497433

Switzerland

+41 62 88979-32

The Netherlands

+31 347 320477

Türkiye

+90 216 5775552

United Kingdom

+44 1536 460866

You can reach our international hotline on:

+49 711 3409-222

support@pilz.com

Reporting security vulnerabilities or security incidents

If you would like to report a security vulnerability or a security incident in connection with a Pilz product, please contact our **Pilz Product Security Incident Response Team (PSIRT)**.

You can reach us at: www.pilz.com/psirt

Pilz develops environmentally-friendly products using ecological materials and energy-saving technologies. Offices and production facilities are ecologically designed, environmentally-aware and energy-saving. So Pilz offers sustainability, plus the security of using energy-efficient products and environmentally-friendly solutions.



www.pilz.com/facebook



www.pilz.com/linkedin



www.pilz.com/xing



www.pilz.com/youtube



1003790-EN-09, 2026-04 Printed in Germany
© Pilz GmbH & Co. KG, 2024

CECE, CHRE, CMSE®, IndustrialPi®, Leansate®, MYZEL®, PAS4000®, PAScal®, PASconfig®, Pilz®, PIR®, PMCprimo®, PMCprotego®, PMCTendo®, PMD®, PMI®, PNOZ®, Primo®, PSEN®, PSS®, PVS®, SafetyBUS p®, SafetyNET p®, THE SPIRIT OF SAFETY® are registered and protected trademarks of Pilz GmbH & Co. KG in some countries. We would point out that product features may vary from the details stated in this document, depending on the status at the time of publication and the scope of the equipment. We accept no responsibility for the validity, accuracy and entirety of the text and graphics presented in this information. Please contact our Technical Support if you have any questions.

We are represented internationally. Please refer to our homepage www.pilz.com for further details or contact our headquarters.

Headquarters: Pilz GmbH & Co. KG, Felix-Wankel-Straße 2, 73760 Ostfildern, Germany
Telephone: +49 711 3409-0, E-Mail: info@pilz.com, Internet: www.pilz.com

PILZ
THE SPIRIT OF SAFETY