



## ► PNOZ X8P

**PILZ**  
THE SPIRIT OF SAFETY

Operating Manual-19820-EN-14  
- Safety relays



This document is the original document.

Where unavoidable, for reasons of readability, the masculine form has been selected when formulating this document. We do assure you that all persons are regarded without discrimination and on an equal basis.

All rights to this documentation are reserved by Pilz GmbH & Co. KG. Copies may be made for the user's internal purposes. Suggestions and comments for improving this documentation will be gratefully received.

CECE®, CHRE®, CMSE®, INDUSTRIAL PI®, Leansafe®, MYZEL®, PAS4000®, PAS-cal®, PASconfig®, Pilz®, PIT®, PMCprimo®, PMCprotego®, PMctendo®, PMD®, PMI®, PNOZ®, Primo®, PSEN®, PSS®, PVIS®, SafetyBUS p®, SafetyEYE®, SafetyNET p®, THE SPIRIT OF SAFETY® are registered and protected trademarks of Pilz GmbH & Co. KG in some countries.



SD means Secure Digital

<b>Introduction</b> .....	<b>5</b>
Validity of documentation .....	5
Using the documentation .....	5
Definition of symbols .....	5
<b>Safety</b> .....	<b>6</b>
Intended use .....	6
Safety regulations .....	6
Safety assessment .....	6
Use of qualified personnel .....	7
Warranty and liability .....	7
Disposal .....	7
For your safety .....	7
<b>Unit features</b> .....	<b>8</b>
<b>Safety features</b> .....	<b>8</b>
<b>Block diagram/terminal configuration</b> .....	<b>9</b>
<b>Function Description</b> .....	<b>9</b>
Operating modes .....	10
Timing diagram .....	11
<b>Installation</b> .....	<b>11</b>
<b>Wiring</b> .....	<b>12</b>
<b>Preparing for operation</b> .....	<b>13</b>
<b>Operation</b> .....	<b>15</b>
Status indicators .....	16
<b>Faults – Interference</b> .....	<b>16</b>
<b>Dimensions in mm</b> .....	<b>17</b>
<b>Technical details</b> .....	<b>18</b>
<b>Safety characteristic data</b> .....	<b>23</b>
<b>Supplementary data</b> .....	<b>24</b>
Service life graph .....	24

<b>Remove plug-in terminals .....</b>	<b>25</b>
<b>Order reference .....</b>	<b>25</b>
<b>EU/EC declaration of conformity .....</b>	<b>26</b>
<b>UKCA-Declaration of Conformity .....</b>	<b>26</b>

## Introduction

### Validity of documentation

This documentation is valid for the product PNOZ X8P. It is valid until new documentation is published.

This operating manual explains the function and operation, describes the installation and provides guidelines on how to connect the product.

### Using the documentation

This document is intended for instruction. Only install and commission the product if you have read and understood this document. The document should be retained for future reference.

### Definition of symbols

Information that is particularly important is identified as follows:



#### **DANGER!**

This warning must be heeded! It warns of a hazardous situation that poses an immediate threat of serious injury and death and indicates preventive measures that can be taken.



#### **WARNING!**

This warning must be heeded! It warns of a hazardous situation that could lead to serious injury and death and indicates preventive measures that can be taken.



#### **CAUTION!**

This refers to a hazard that can lead to a less serious or minor injury plus material damage, and also provides information on preventive measures that can be taken.



#### **NOTICE**

This describes a situation in which the product or devices could be damaged and also provides information on preventive measures that can be taken. It also highlights areas within the text that are of particular importance.

**INFORMATION**

This gives advice on applications and provides information on special features.

**Safety****Intended use**

The safety relay PNOZ X8P provides a safety-related interruption of a safety circuit.

The safety relay meets the requirements of EN 60947-5-1 and EN 60204-1 and may be used in applications with:

- ▶ E-STOP pushbuttons
- ▶ Safety gates
- ▶ Light grids and safety switches with detection of shorts across contacts

**Improper use**

The following is deemed improper use in particular:

- ▶ Any component, technical or electrical modification to the product,
- ▶ Use of the product outside the areas described in this operating manual,
- ▶ Use of the product outside the technical details (see chapter entitled [Technical Details](#) [ 18]).

**NOTICE****EMC-compliant electrical installation**

The product is designed for use in an industrial environment. The product may cause interference if installed in other environments. If installed in other environments, measures should be taken to comply with the applicable standards and directives for the respective installation site with regard to interference.

**Safety regulations****Safety assessment**

Before using a unit, a risk assessment is required in accordance with the Machinery Regulation.

Connecting additional units may result in further risks. Take the necessary measures to protect against corruption.

The product as an individual component fulfils the functional safety requirements in accordance with EN ISO 13849 and EN IEC 62061. However, this does not guarantee the functional safety of the overall plant/machine. To achieve the relevant safety level of the overall plant/machine's required safety functions, each safety function needs to be considered separately.

**Use of qualified personnel**

The products may only be assembled, installed, programmed, commissioned, operated, de-commissioned and maintained by persons who are competent to do so.

A competent person is a qualified and knowledgeable person who, because of their training, experience and current professional activity, has the specialist knowledge required. In order to inspect, assess and handle products, devices, systems, plant and machinery, this person must be familiar with the state of the art and the applicable national, European and international laws, directives and standards.

It is the company's responsibility only to employ personnel who

- ▶ Are familiar with the basic regulations concerning health and safety / accident prevention,
- ▶ Have read and understood the information provided in the section entitled Safety
- ▶ Have a good knowledge of the generic and specialist standards applicable to the specific application.

**Warranty and liability**

All claims to warranty and liability will be rendered invalid if

- ▶ The product was used contrary to the purpose for which it is intended,
- ▶ Damage can be attributed to not having followed the guidelines in the manual,
- ▶ Operating personnel are not suitably qualified,
- ▶ Any type of modification has been made (e.g. exchanging components on the PCB boards, soldering work etc.).

**Disposal**

- ▶ In safety-related applications, please comply with the mission time  $T_M$  stated in the safety-related characteristic data.
- ▶ When decommissioning, please comply with local regulations regarding the disposal of electronic devices (e.g. Electrical and Electronic Equipment Act).

**For your safety**

The unit meets all the necessary conditions for safe operation. However, please note the following:

- ▶ Note for overvoltage category III: If voltages higher than low voltage (>50 VAC or >120 VDC) are present on the unit, connected control elements and sensors must have a rated insulation voltage of at least 250 V.

### Unit features

- ▶ Positive-guided relay outputs:
  - 3 safety contacts (N/O), instantaneous
  - 2 auxiliary contacts (N/C), instantaneous
- ▶ 2 semiconductor outputs
- ▶ Connection options for:
  - E-STOP pushbuttons
  - Safety gate limit switches
  - Start button
  - Light guards and safety switches
- ▶ LED indicator for:
  - Supply voltage
  - Input state
  - Switch state of the safety contacts
  - Start circuit
- ▶ Semiconductor outputs signal:
  - Supply voltage is present
  - Switch status of the safety contacts
- ▶ Plug-in connection terminals (either spring-loaded terminal or screw terminal)
- ▶ See order reference for unit types

### Safety features

The safety relay meets the following safety requirements:

- ▶ The circuit is redundant with built-in self-monitoring.
- ▶ The safety function remains effective in the case of a component failure.
- ▶ The correct opening and closing of the safety function relays is tested automatically in each on-off cycle.

## Block diagram/terminal configuration

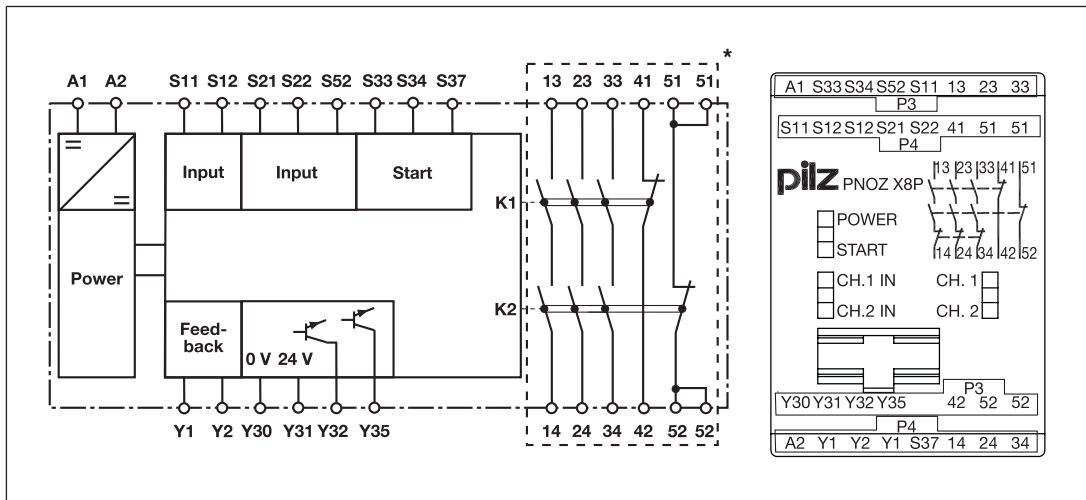

\*Insulation between the non-marked area and the relay contacts: Basic insulation (over-voltage category III), Protective separation (overvoltage category II)

## Function Description

The safety relay PNOZ X8P provides a safety-oriented interruption of a safety circuit. When supply voltage is supplied the "POWER" LED is lit. The unit is ready for operation when the feedback loop Y1-Y2 and the start circuit S33-S34 are closed. The "START" LED is lit.

- ▶ Input circuit is closed (e.g. E-STOP pushbutton not operated):
  - LEDs "CH1 IN" and "CH2 IN" will light.
  - The "START" LED goes out.
  - Safety contacts 13-14, 23-24 and 33-34 are closed, auxiliary contacts 41-42 and 51-52 are opened. The unit is active.
  - LEDs "CH1" and "CH2" will light.
  - A high signal is present at the semiconductor output switch state Y32.
- ▶ Input circuit is opened (e.g. E-STOP pushbutton operated):
  - LEDs "CH1 IN" and "CH2 IN" go out.
  - Safety contacts 13-14, 23-24 and 33-34 are opened redundantly, auxiliary contacts 41-42 and 51-52 are closed.
  - The LEDs "CH1" and "CH2" go out.
  - A low signal is present at the semiconductor output switch state Y32.

Semiconductor output supply voltage Y35

- ▶ A high signal is present at semi-conductor output Y35 if the supply voltage is present and the internal fuse has not blown.

**Operating modes**

- ▶ Single-channel operation: No redundancy in the input circuit, earth faults in the start and input circuit are detected.
- ▶ Dual-channel operation with detection of shorts across contacts: Redundant input circuit, PNOZ X8P detects
  - earth faults in the start and input circuit,
  - short circuits in the input circuit,
  - shorts across contacts in the input circuit.
- ▶ Dual-channel operation without detection of shorts across contacts: Redundant input circuit, detects PNOZ X8P
  - earth faults in the start and input circuit,
  - short circuits in the input circuit.
- ▶ Automatic start: Unit is active once the input circuit has been closed.
- ▶ Manual start: Unit is active once the input circuit and the start circuit are closed.
- ▶ Monitored start: Unit is active once
  - the input circuit is closed and then the start circuit is closed and opened again.
  - the start circuit is closed and then opened again once the input circuit is closed.
- ▶ Increase in the number of available contacts by connecting contact expansion modules or external contactors/relays.

**NOTICE**

The device does not recognise short circuits or shorts across contacts in the start/feedback loop. Take suitable measures, such as fault exclusion through protected or separate installation.

### Timing diagram

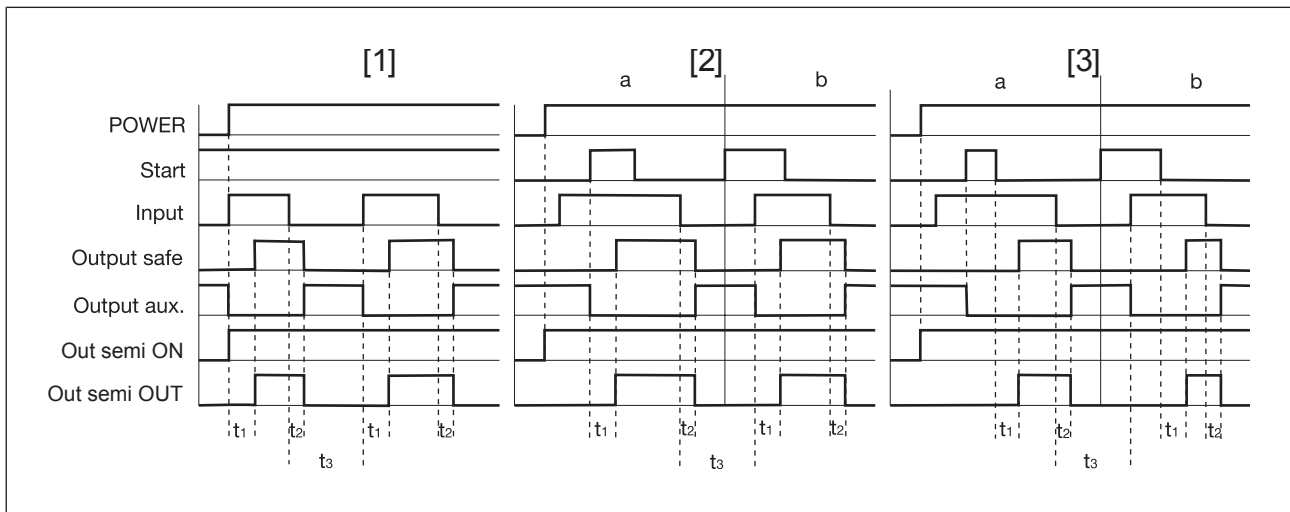

### Legend

- ▶ Power: Supply voltage
- ▶ Start: Start circuit
- ▶ Input: Input circuit
- ▶ Output safe: Safety contacts
- ▶ Output aux.: Auxiliary contacts
- ▶ Out semi ON: Semiconductor output supply voltage
- ▶ Out semi OUT: Semiconductor output switch state
- ▶ [1]: Automatic start
- ▶ [2]: Manual start
- ▶ [3]: Monitored start
- ▶ a: Input circuit closes before start circuit
- ▶ b: Start circuit closes before input circuit
- ▶  $t_1$ : Switch-on delay
- ▶  $t_2$ : Delay-on de-energisation
- ▶  $t_3$ : Recovery time

### Installation



#### NOTICE

#### Protection against manipulation

Protect the product from unauthorised access.

- ▶ The unit should be installed in a control cabinet with a protection type of at least IP54.
- ▶ Use the notch on the rear of the unit to attach it to a DIN rail (35 mm).
- ▶ When installed vertically: secure the unit by using a fixing element (e.g. retaining bracket or end angle).

## Wiring

Please note:

- ▶ Information given in the "[Technical details \[18\]](#)" must be followed.
- ▶ Delivery status of units with screw terminals: Link between Y1-Y2 (feedback loop)
- ▶ Outputs 13-14, 23-24, 33-34 are safety contacts, outputs 41-42, 51-52 are auxiliary contacts (e.g. for display).
- ▶ Do **not** use auxiliary contacts 41-42, 51-52 for safety circuits!
- ▶ Do not connect undesignated terminals.
- ▶ To prevent contact welding, a fuse should be connected before the output contacts (see [Technical details \[18\]](#)).
- ▶ Calculation of the max. cable length  $l_{\max}$  in the input circuit:

$$l_{\max} = \frac{R_{l_{\max}}}{R_l / \text{km}}$$

$R_{l_{\max}}$  = max. overall cable resistance (see [Technical details \[18\]](#))

$R_l / \text{km}$  = cable resistance/km

- ▶ Use copper wiring with a temperature stability of 60/75 °C.
- ▶ To prevent EMC interferences (particularly common-mode interferences) the measures described in EN 60204-1 must be executed. This includes the separate routing of cables of the control circuits (input, start and feedback loop) from other cables for energy transmission or the shielding of cables, for example.
- ▶ Adequate protection circuit must be provided on all output contacts with capacitive and inductive loads.
- ▶ Do not switch low currents using contacts that have been used previously with high currents.
- ▶ When connecting magnetically operated, reed proximity switches, ensure that the max. peak inrush current (on the input circuit) does not overload the proximity switch.
- ▶ On 24 VDC devices:  
The power supply must comply with the regulations for extra low voltages with protective electrical separation (SELV, PELV) in accordance with VDE 0100, Part 410.
- ▶ Semiconductor output supply voltage: Connect surge protection elements between the Y30 and Y31 connections and any DC distribution network (not SELV/PELV) fed from outside of the electrical installation area.

### Important for detection of shorts across contacts:

As this function for detecting shorts across contacts is not failsafe, it is tested by Pilz during the final control check. If there is a danger of exceeding the cable runs, we recommend the following test after the installation of the device:

1. Unit ready for operation (output contacts closed)
2. Short circuit the test terminals S12, S22 for detecting shorts across the inputs.
3. The unit's fuse must be triggered and the output contacts must open. Cable lengths in the scale of the maximum length can delay the fuse triggering for up to 2 minutes.
4. Reset the fuse: remove the short circuit and switch off the supply voltage for approx. 1 minute.

### Preparing for operation

Supply voltage	AC	DC
Input circuit	Single-channel	Dual-channel
E-STOP <b>without</b> detection of shorts across contacts		
E-STOP <b>with</b> detection of shorts across contacts		
Safety gate <b>without</b> detection of shorts across contacts		<p>Simultaneity S1 and S2: 150 ms</p>
Safety gate <b>with</b> detection of shorts across contacts		
Light guard or safety switch, detection of shorts across contacts via ESPE (only when $U_B = 24$ VDC)		



**NOTICE**

With single-channel wiring, the safety level of your plant/machine may be lower than the safety level of the unit (see Safety characteristic data). To achieve the stated safety level, appropriate measures must be taken on single-channel applications to exclude faults in the input circuit. Examples of such measures are: protected cable routing and positive-opening contacts in the E-STOP pushbutton.



**NOTICE**

**Operation with a light guard or safety switch**

It must not be possible to switch off the supply voltage for the PNOZ X8P separately from the supply voltage for the light guard or safety switch.

Start circuit	E-STOP/safety gate wiring (single-channel, dual-channel without detection of shorts across contacts)	E-STOP/safety gate wiring (dual-channel with detection of shorts across contacts)
Automatic start		
Automatic start with start-up test		
Manual start		
Monitored start		



**NOTICE**

**In the event of an automatic start or manual start with bridged start contact (fault):**

The unit starts up automatically when the safeguard is reset, e.g. when the E-STOP pushbutton is released. Use external circuit measures to prevent an unexpected restart.

Feedback loop	without feedback loop monitoring	with feedback loop monitoring
Link or contacts from external contactors		
Semiconductor output		

**Legend**

- ▶ S1: E-STOP pushbuttons
- ▶ S3: Start button
- ▶ ⬆: Switch operated
- ▶ : Gate open
- ▶ : Gate closed

**Operation**

When the relay outputs are switched on, the mechanical contact on the relay cannot be tested automatically. Depending on the operational environment, measures to detect the non-opening of switching elements may be required under some circumstances.

When the product is used in accordance with the European Machinery Regulation, a check must be carried out to ensure that the safety contacts on the relay outputs open correctly. Open the safety contacts (switch off output) and start the device again, so that the internal diagnostics can check that the safety contacts open correctly

- ▶ For SIL 3/PL e, at least 1x per month
- ▶ For SIL 2/PL d, at least 1x per year

**NOTICE**

The safety functions should be checked after initial commissioning and each time the plant/machine is changed. The safety functions may only be checked by qualified personnel.

**Status indicators**

LEDs indicate the status and errors during operation:



LED on

**POWER**

Supply voltage is present.

**START**

Start circuit is closed.

**CH.1 IN**

Channel 1 input circuit is closed.

**CH.2 IN**

Channel 2 input circuit is closed.

**CH.1**

Safety contacts of channel 1 are closed.

**CH.2**

Safety contacts of channel 2 are closed.

**Faults – Interference**

- ▶ Earth fault: The supply voltage fails and the safety contacts open. Once the cause of the respective fault has been rectified and the supply voltage is switched off for approx. 1 minute, the unit is ready for operation again.
- ▶ Contact malfunctions: If the contacts have welded, reactivation will not be possible after the input circuit has opened.
- ▶ LED "POWER" does not light: Short circuit or no supply voltage.

### Dimensions in mm

\* With spring-loaded terminals

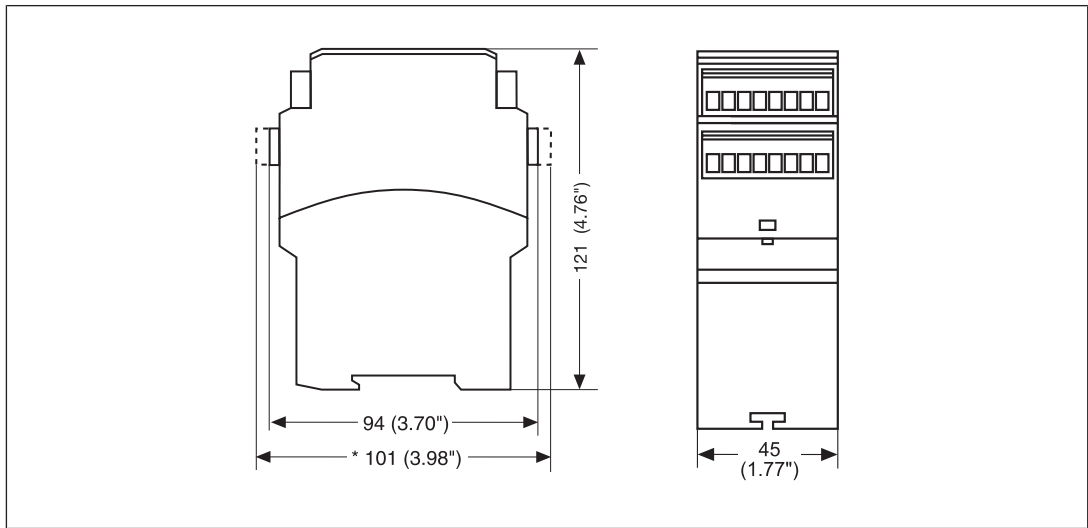

## Technical details

Where standards are undated, the 2022-09 valid editions apply.

General	777760	787760
Certifications	CCC, CE, EAC, TÜV, UKCA, cULus Listed	CCC, CE, EAC, TÜV, UKCA, cULus Listed
Electrical data	777760	787760
Supply voltage		
Voltage	24 V	24 V
Kind	DC	DC
Voltage tolerance	-15 %/+10 %	-15 %/+10 %
Output of external power supply (DC)	2,5 W	2,5 W
Residual ripple DC	160 %	160 %
Duty cycle	100 %	100 %
Max. inrush current impulse		
Current pulse, A1	10 A	10 A
Pulse duration, A1	0,5 ms	0,5 ms
Inputs	777760	787760
Quantity	2	2
Voltage at		
Input circuit DC	24 V	24 V
Start circuit DC	24 V	24 V
Feedback loop DC	24 V	24 V
Current at		
Input circuit DC	45 mA	45 mA
Start circuit DC	50 mA	50 mA
Feedback loop DC	50 mA	50 mA
Min. input resistance at power-on	89 Ohm	89 Ohm
Max. overall cable resistance R <sub>I</sub> -max		
Single-channel at UB DC	100 Ohm	100 Ohm
Dual-channel without detection of shorts across contacts at UB DC	200 Ohm	200 Ohm
Dual-channel with detection of shorts across contacts at UB DC	16 Ohm	16 Ohm
Semiconductor outputs	777760	787760
Quantity	2	2
Voltage	24 V	24 V
Current	50 mA	50 mA
External supply voltage	24 V	24 V
Voltage tolerance	-20 %/+20 %	-20 %/+20 %
Residual current at "0" signal	0,1 mA	0,1 mA
Max. internal voltage drop	4 V	4 V

<b>Semiconductor outputs</b>		
	<b>777760</b>	<b>787760</b>
Conditional rated short circuit current	<b>100 A</b>	<b>100 A</b>
Lowest operating current	<b>0 mA</b>	<b>0 mA</b>
Utilisation category in accordance with EN 60947-1	<b>DC-12</b>	<b>DC-12</b>
<b>Relay outputs</b>		
	<b>777760</b>	<b>787760</b>
Number of output contacts		
Safety contacts (N/O), instantaneous	<b>3</b>	<b>3</b>
Auxiliary contacts (N/C)	<b>2</b>	<b>2</b>
Max. short circuit current I <sub>K</sub>	<b>1 kA</b>	<b>1 kA</b>
Utilisation category		
in accordance with the standard	<b>EN 60947-4-1</b>	<b>EN 60947-4-1</b>
Utilisation category of safety contacts		
AC1 at	<b>240 V</b>	<b>240 V</b>
Min. current	<b>0,01 A</b>	<b>0,01 A</b>
Max. current	<b>8 A</b>	<b>8 A</b>
Max. power	<b>2.000 VA</b>	<b>2.000 VA</b>
DC1 at	<b>24 V</b>	<b>24 V</b>
Min. current	<b>0,01 A</b>	<b>0,01 A</b>
Max. current	<b>8 A</b>	<b>8 A</b>
Max. power	<b>200 W</b>	<b>200 W</b>
Utilisation category of auxiliary contacts		
AC1 at	<b>240 V</b>	<b>240 V</b>
Min. current	<b>0,01 A</b>	<b>0,01 A</b>
Max. current	<b>8 A</b>	<b>8 A</b>
Max. power	<b>2000 VA</b>	<b>2000 VA</b>
DC1 at	<b>24 V</b>	<b>24 V</b>
Min. current	<b>0,01 A</b>	<b>0,01 A</b>
Max. current	<b>8 A</b>	<b>8 A</b>
Max. power	<b>200 W</b>	<b>200 W</b>
Utilisation category		
in accordance with the standard	<b>EN 60947-5-1</b>	<b>EN 60947-5-1</b>
Utilisation category of safety contacts		
AC15 at	<b>230 V</b>	<b>230 V</b>
Max. current	<b>5 A</b>	<b>5 A</b>
DC13 (6 cycles/min) at	<b>24 V</b>	<b>24 V</b>
Max. current	<b>7 A</b>	<b>7 A</b>

<b>Relay outputs</b>	<b>777760</b>	<b>787760</b>
Utilisation category of auxiliary contacts		
AC15 at	<b>230 V</b>	<b>230 V</b>
Max. current	<b>5 A</b>	<b>5 A</b>
DC13 (6 cycles/min) at	<b>24 V</b>	<b>24 V</b>
Max. current	<b>7 A</b>	<b>7 A</b>
Utilisation category in accordance with UL		
Voltage with current	<b>240 V AC G. P. 8 A</b>	<b>240 V AC G. P. 8 A</b>
Voltage with current	<b>24 V DC Resistive 5 A</b>	<b>24 V DC Resistive 5 A</b>
Pilot Duty	<b>B300, R300</b>	<b>B300, R300</b>
External contact fuse protection, safety contacts		
in accordance with the standard	<b>EN 60947-5-1</b>	<b>EN 60947-5-1</b>
Max. melting integral	<b>240 A<sup>2</sup>s</b>	<b>240 A<sup>2</sup>s</b>
Blow-out fuse, quick	<b>10 A</b>	<b>10 A</b>
Blow-out fuse, slow	<b>6 A</b>	<b>6 A</b>
Blow-out fuse, gG	<b>10 A</b>	<b>10 A</b>
Circuit breaker 24V AC/DC, characteristic B/C	<b>6 A</b>	<b>6 A</b>
External contact fuse protection, auxiliary contacts		
Max. melting integral	<b>240 A<sup>2</sup>s</b>	<b>240 A<sup>2</sup>s</b>
Blow-out fuse, quick	<b>10 A</b>	<b>10 A</b>
Blow-out fuse, slow	<b>6 A</b>	<b>6 A</b>
Blow-out fuse, gG	<b>10 A</b>	<b>10 A</b>
Circuit breaker, 24 V AC/DC, characteristic B/C	<b>6 A</b>	<b>6 A</b>
Contact material	<b>AgSnO<sub>2</sub> + 0,2 µm Au</b>	<b>AgSnO<sub>2</sub> + 0,2 µm Au</b>
<b>Conventional thermal current while loading several contacts</b>	<b>777760</b>	<b>787760</b>
I <sub>th</sub> per contact at UB DC; AC1: 240 V, DC1: 24 V		
Conv. therm. current with 1 contact	<b>8 A</b>	<b>8 A</b>
Conv. therm. current with 2 contacts	<b>8 A</b>	<b>8 A</b>
Conv. therm. current with 3 contacts	<b>7 A</b>	<b>7 A</b>

<b>Times</b>	<b>777760</b>	<b>787760</b>
<b>Switch-on delay</b>		
with automatic start typ.	<b>160 ms</b>	<b>160 ms</b>
with automatic start max.	<b>200 ms</b>	<b>200 ms</b>
with automatic start after power on typ.	<b>185 ms</b>	<b>185 ms</b>
with automatic start after power on max.	<b>220 ms</b>	<b>220 ms</b>
with manual start typ.	<b>190 ms</b>	<b>190 ms</b>
with manual start max.	<b>250 ms</b>	<b>250 ms</b>
with monitored start typ.	<b>130 ms</b>	<b>130 ms</b>
with monitored start max.	<b>180 ms</b>	<b>180 ms</b>
<b>Delay-on de-energisation</b>		
with E-STOP typ.	<b>15 ms</b>	<b>15 ms</b>
with E-STOP max.	<b>30 ms</b>	<b>30 ms</b>
with power failure typ.	<b>100 ms</b>	<b>100 ms</b>
with power failure max.	<b>200 ms</b>	<b>200 ms</b>
<b>Recovery time at max. switching frequency 1/s</b>		
after E-STOP	<b>50 ms</b>	<b>50 ms</b>
after power failure	<b>180 ms</b>	<b>180 ms</b>
<b>Min. start pulse duration with a monitored start</b>		
	<b>30 ms</b>	<b>30 ms</b>
<b>Supply interruption before de-energisation</b>		
	<b>35 ms</b>	<b>35 ms</b>
<b>Environmental data</b>		
<b>Climatic suitability</b>		
	<b>EN 60068-2-78</b>	<b>EN 60068-2-78</b>
<b>Ambient temperature</b>		
Temperature range	<b>-10 - 55 °C</b>	<b>-10 - 55 °C</b>
<b>Storage temperature</b>		
Temperature range	<b>-40 - 85 °C</b>	<b>-40 - 85 °C</b>
<b>Climatic suitability</b>		
Humidity	<b>93 % r. h. at 40 °C</b>	<b>93 % r. h. at 40 °C</b>
<b>Condensation during operation</b>		
	<b>Not permitted</b>	<b>Not permitted</b>
<b>EMC</b>		
	<b>EN 60947-5-1, EN 61000-6-2, EN 61326-3-1</b>	<b>EN 60947-5-1, EN 61000-6-2, EN 61326-3-1</b>
<b>Vibration</b>		
in accordance with the standard	<b>EN 60068-2-6</b>	<b>EN 60068-2-6</b>
Frequency	<b>10 - 55 Hz</b>	<b>10 - 55 Hz</b>
Amplitude	<b>0,35 mm</b>	<b>0,35 mm</b>
<b>Airgap creepage</b>		
in accordance with the standard	<b>EN 60947-1</b>	<b>EN 60947-1</b>
Overvoltage category	<b>III / II</b>	<b>III / II</b>
Pollution degree	<b>2</b>	<b>2</b>
<b>Rated insulation voltage</b>		
	<b>250 V</b>	<b>250 V</b>
<b>Rated impulse withstand voltage</b>		
	<b>4 kV</b>	<b>4 kV</b>

<b>Environmental data</b>	<b>777760</b>	<b>787760</b>
Protection type		
Housing	<b>IP40</b>	<b>IP40</b>
Terminals	<b>IP20</b>	<b>IP20</b>
Mounting area (e.g. control cabinet)	<b>IP54</b>	<b>IP54</b>
<b>Mechanical data</b>	<b>777760</b>	<b>787760</b>
Mounting position	<b>Any</b>	<b>Any</b>
Mechanical life	<b>10,000,000 cycles</b>	<b>10,000,000 cycles</b>
Material		
Bottom	<b>PPO UL 94 V1</b>	<b>PPO UL 94 V1</b>
Front	<b>ABS UL 94 V0</b>	<b>ABS UL 94 V0</b>
Top	<b>PPO UL 94 V1</b>	<b>PPO UL 94 V1</b>
Connection type	<b>Screw terminal</b>	<b>Spring-loaded terminal</b>
Mounting type	<b>plug-in</b>	<b>plug-in</b>
Conductor cross section with screw terminals		
1 core flexible	<b>0,25 - 2,5 mm<sup>2</sup>, 24 - 12 AWG</b>	–
2 core with the same cross section, flexible with crimp connectors, no plastic sleeve	<b>0,25 - 1 mm<sup>2</sup>, 24 - 16 AWG</b>	–
2 core with the same cross section, flexible without crimp connectors or with TWIN crimp connectors	<b>0,2 - 1,5 mm<sup>2</sup>, 24 - 16 AWG</b>	–
Torque setting with screw terminals	<b>0,5 Nm</b>	–
Stripping length with screw terminals	<b>7 mm</b>	–
Conductor cross section with spring-loaded terminals: Flexible with/without crimp connector	–	<b>0,2 - 1,5 mm<sup>2</sup>, 24 - 16 AWG</b>
Spring-loaded terminals: Terminal points per connection	–	<b>2</b>
Stripping length with spring-loaded terminals	–	<b>8 mm</b>
Dimensions		
Height	<b>94 mm</b>	<b>101 mm</b>
Width	<b>45 mm</b>	<b>45 mm</b>
Depth	<b>121 mm</b>	<b>121 mm</b>
Weight	<b>315 g</b>	<b>315 g</b>

## Safety characteristic data



### NOTICE

You must comply with the safety characteristic data in order to achieve the required safety level for your plant/machine.

Operating mode	EN ISO 13849-1: 2023	EN ISO 13849-1: 2023	EN IEC 62061 SIL CL/max.	EN IEC 62061 61508	EN/IEC 61511 61508	EN/IEC 61511 61508	EN ISO 13849-1: 2023
	PL	Category	SIL	PFH [1/h]	SIL	PFD	$T_M$ [year]
–	PL e	Cat. 4	SIL 3	2,31E-09	SIL 3	2,03E-06	20

Explanatory notes for the safety-related characteristic data:

- ▶  $T_M$  is the maximum mission time in accordance with EN ISO 13849-1. The value also applies as the retest interval in accordance with EN IEC 61508-6 and EN IEC 61511 and as the proof test interval and mission time in accordance with EN IEC 62061.

All the units used within a safety function must be considered when calculating the safety characteristic data.



### INFORMATION

A safety function's SIL/PL values are **not** identical to the SIL/PL values of the products used and may differ from these.



### CAUTION!

It is essential to consider the relay's service life graphs. The relay outputs' safety-related characteristic data is only valid if the values in the service life graphs are met.

The PFH value depends on the switch frequency and the load of the relay output. If the service life graphs are not accessible, the stated PFH value can be used irrespective of the switch frequency and the load, as the PFH value already considers the relay's B10d value as well as the failure rates of the other components.

## Supplementary data

### Service life graph

The service life graphs indicate the number of cycles from which failures due to wear must be expected. The wear is mainly caused by the electrical load; the mechanical load is negligible.

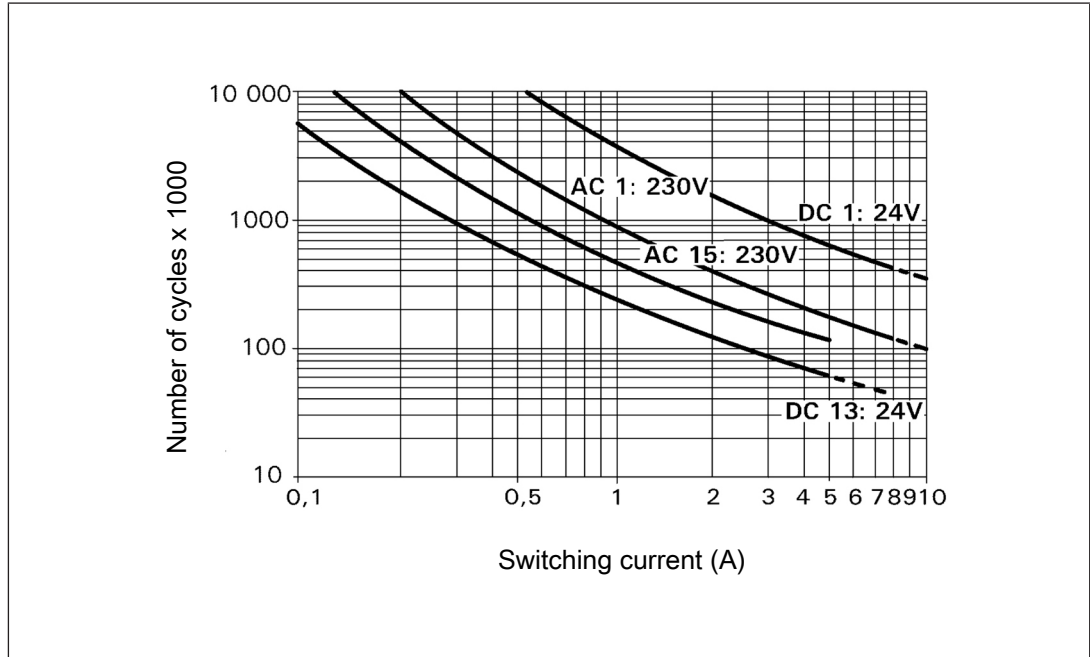

### Example

- ▶ Inductive load: 0.2 A
- ▶ Utilisation category: AC15
- ▶ Contact service life: 4 000 000 cycles

Provided the application to be implemented requires fewer than 4 000 000 cycles, the PFH value (see Technical details) can be used in the calculation.

To increase the service life, sufficient spark suppression must be provided on all output contacts. With capacitive loads, any power surges that occur must be noted. With DC contactors, use flywheel diodes for spark suppression.

## Remove plug-in terminals

### Procedure

▶ Insert a suitable screwdriver into the housing recess behind the terminal.

Do **not** remove the terminals by pulling the cables!

▶ Lever the terminal out.

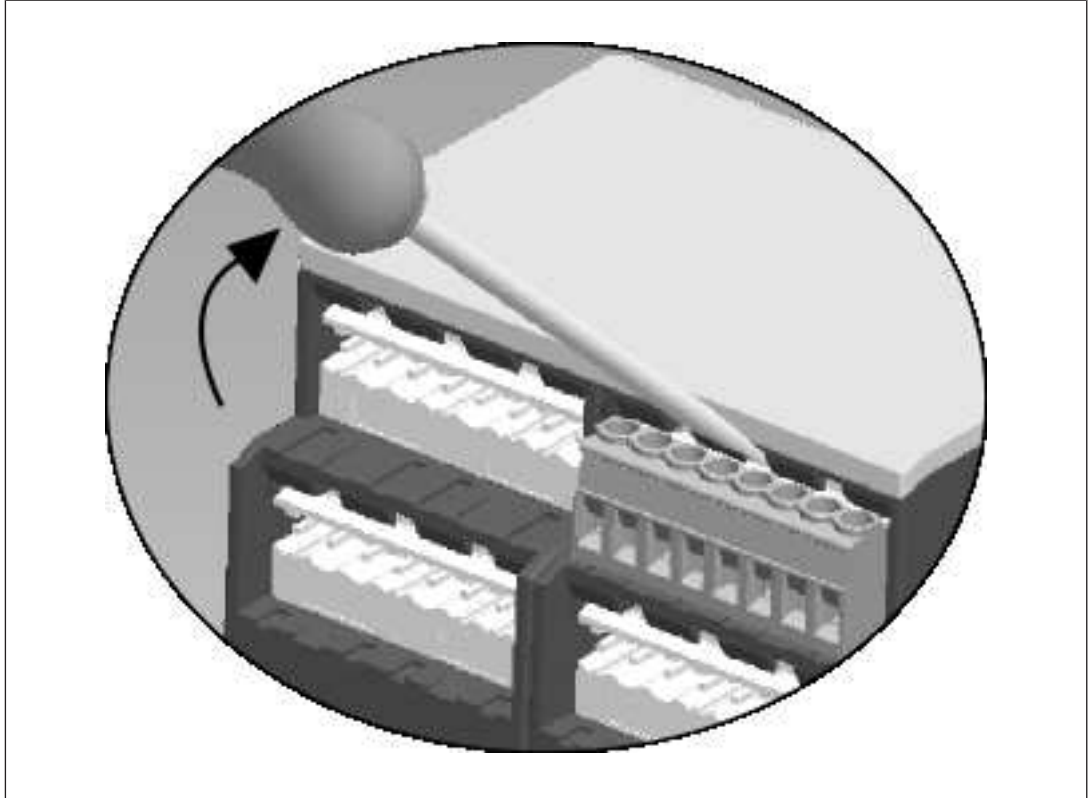

### Order reference

Product type	Features	Connection type	Product ID
PNOZ X8P	24 VDC	Screw terminals	777760
PNOZ X8P C	24 VDC	Spring-loaded terminals	787760

### **EU/EC declaration of conformity**

These products meet the requirements of the directive 2006/42/EC on machinery up to and including 19 January 2027, and the EU regulation 2023/1230 of the European Parliament and of the Council from 20 January 2027. The full EU and EC declaration of conformity is available to download at [www.pilz.com/manuals](http://www.pilz.com/manuals).

Authorised representative: Pilz GmbH & Co. KG, Felix-Wankel-Str. 2, 73760 Ostfildern, Germany

### **UKCA-Declaration of Conformity**

These products comply with following UK legislation: Supply of Machinery (Safety) Regulation 2008.

The complete UKCA Declaration of Conformity is available on the Internet at [www.pilz.com/manuals](http://www.pilz.com/manuals).

Representative: Pilz Automation Technology, Pilz House, Little Colliers Field, Corby, Northamptonshire, NN18 8TJ United Kingdom, eMail: [mail@pilz.co.uk](mailto:mail@pilz.co.uk)

# Support

Technical support is available from Pilz round the clock.

## Americas

### Brazil

+55 11 97569-2804

### Canada

+1 888 315 7459

### Mexico

+52 55 5572 1300

### USA (toll-free)

+1 877-PILZUSA (745-9872)

## Asia

### China

+86 400-088-3566

### Japan

+81 45 471-2281

### South Korea

+82 31 778 3390

## Australia and Oceania

### Australia

+61 3 95600621

### New Zealand

+64 9 6345350

## Europe

### Austria

+43 1 7986263-444

### Belgium, Luxembourg

+32 9 3217570

### France

+33 3 88104003

### Germany

+49 711 3409-444

### Ireland

+353 21 4804983

### Italy, Malta

+39 0362 1826711

## Scandinavia

+45 74436332

## Spain

+34 938497433

## Switzerland

+41 62 88979-32

## The Netherlands

+31 347 320477

## Türkiye

+90 216 5775552

## United Kingdom

+44 1536 460866

## You can reach our international hotline on:

+49 711 3409-222

support@pilz.com

## Reporting security vulnerabilities or security incidents

If you would like to report a security vulnerability or a security incident in connection with a Pilz product, please contact our **Pilz Product Security Incident Response Team (PSIRT)**.

You can reach us at: [www.pilz.com/psirt](http://www.pilz.com/psirt)

Pilz develops environmentally-friendly products using ecological materials and energy-saving technologies. Offices and production facilities are ecologically designed, environmentally-aware and energy-saving. So Pilz offers sustainability, plus the security of using energy-efficient products and environmentally-friendly solutions.



[www.pilz.com/facebook](http://www.pilz.com/facebook)



[www.pilz.com/linkedin](http://www.pilz.com/linkedin)



[www.pilz.com/xing](http://www.pilz.com/xing)



[www.pilz.com/youtube](http://www.pilz.com/youtube)



We are represented internationally. Please refer to our homepage [www.pilz.com](http://www.pilz.com) for further details or contact our headquarters.

Headquarters: Pilz GmbH & Co. KG, Felix-Wankel-Straße 2, 73760 Ostfildern, Germany  
Telephone: +49 711 3409-0, E-Mail: [info@pilz.com](mailto:info@pilz.com), Internet: [www.pilz.com](http://www.pilz.com)

**PILZ**  
THE SPIRIT OF SAFETY

19820-EN-14, 2026-03 Printed in Germany  
© Pilz GmbH & Co. KG, 2024  
CECE, CHRE, CMSE®, IndustrialPi®, Leansate®, MYZEL®, PAS4000®, PAScal®, PASconfig®, Pilz®, PIT®, PMCPrimo®, PMCProtego®, PMCTendo®, PMD®, PMM®, PNOZ®, Primo®, PSEN®, PSS®, PVS®, SafetyBUS p®, SafetyNET p®, THE SPIRIT OF SAFETY® are registered and protected trademarks of Pilz GmbH & Co. KG in some countries. We would point out that product features may vary from the details stated in this document, depending on the status at the time of publication and the scope of the equipment. We accept no responsibility for the validity, accuracy and entirety of the text and graphics presented in this information. Please contact our Technical Support if you have any questions.