



▶ PNOZ X2.4V

PILZ

THE SPIRIT OF SAFETY

Operating Manual-20219-EN-12
- Safety relays



This document is the original document.

Where unavoidable, for reasons of readability, the masculine form has been selected when formulating this document. We do assure you that all persons are regarded without discrimination and on an equal basis.

All rights to this documentation are reserved by Pilz GmbH & Co. KG. Copies may be made for the user's internal purposes. Suggestions and comments for improving this documentation will be gratefully received.

CECE®, CHRE®, CMSE®, INDUSTRIAL PI®, Leansafe®, MYZEL®, PAS4000®, PAS-cal®, PASconfig®, Pilz®, PIT®, PMCprimo®, PMCprotego®, PMctendo®, PMD®, PMI®, PNOZ®, Primo®, PSEN®, PSS®, PVIS®, SafetyBUS p®, SafetyEYE®, SafetyNET p®, THE SPIRIT OF SAFETY® are registered and protected trademarks of Pilz GmbH & Co. KG in some countries.



SD means Secure Digital

Introduction	4
Validity of documentation	4
Using the documentation	4
Definition of symbols	4
Safety	5
Intended use	5
Safety regulations	5
Safety assessment	5
Use of qualified personnel	6
Warranty and liability	6
Disposal	6
For your safety	6
Unit features	7
Safety features	7
Block diagram/terminal configuration	7
Function Description	8
Operating modes	8
Timing diagram	9
Installation	10
Wiring	10
Preparing for operation	12
Operation	14
Status indicators	15
Faults – Interference	15
Dimensions in mm	15
Technical details	16
Safety characteristic data	19
Supplementary data	20
Service life graph	20
Order reference	21
EU/EC declaration of conformity	21
UKCA-Declaration of Conformity	21

Introduction

Validity of documentation

This documentation is valid for the product PNOZ X2.4V. It is valid until new documentation is published.

This operating manual explains the function and operation, describes the installation and provides guidelines on how to connect the product.

Using the documentation

This document is intended for instruction. Only install and commission the product if you have read and understood this document. The document should be retained for future reference.

Definition of symbols

Information that is particularly important is identified as follows:



DANGER!

This warning must be heeded! It warns of a hazardous situation that poses an immediate threat of serious injury and death and indicates preventive measures that can be taken.



WARNING!

This warning must be heeded! It warns of a hazardous situation that could lead to serious injury and death and indicates preventive measures that can be taken.



CAUTION!

This refers to a hazard that can lead to a less serious or minor injury plus material damage, and also provides information on preventive measures that can be taken.



NOTICE

This describes a situation in which the product or devices could be damaged and also provides information on preventive measures that can be taken. It also highlights areas within the text that are of particular importance.



INFORMATION

This gives advice on applications and provides information on special features.

Safety

Intended use

The safety relay PNOZ X2.4V provides a safety-related interruption of a safety circuit.

The safety relay meets the requirements of EN 60947-5-1 and EN 60204-1 and may be used in applications with:

- ▶ E-STOP pushbuttons
- ▶ Safety gates

Improper use

The following is deemed improper use in particular:

- ▶ Any component, technical or electrical modification to the product,
- ▶ Use of the product outside the areas described in this operating manual,
- ▶ Use of the product outside the technical details (see chapter entitled [Technical Details](#) [ 16]).



NOTICE

EMC-compliant electrical installation

The product is designed for use in an industrial environment. The product may cause interference if installed in other environments. If installed in other environments, measures should be taken to comply with the applicable standards and directives for the respective installation site with regard to interference.

Safety regulations

Safety assessment

Before using a unit, a risk assessment is required in accordance with the Machinery Regulation.

Connecting additional units may result in further risks. Take the necessary measures to protect against corruption.

The product as an individual component fulfils the functional safety requirements in accordance with EN ISO 13849 and EN IEC 62061. However, this does not guarantee the functional safety of the overall plant/machine. To achieve the relevant safety level of the overall plant/machine's required safety functions, each safety function needs to be considered separately.

Use of qualified personnel

The products may only be assembled, installed, programmed, commissioned, operated, de-commissioned and maintained by persons who are competent to do so.

A competent person is a qualified and knowledgeable person who, because of their training, experience and current professional activity, has the specialist knowledge required. In order to inspect, assess and handle products, devices, systems, plant and machinery, this person must be familiar with the state of the art and the applicable national, European and international laws, directives and standards.

It is the company's responsibility only to employ personnel who

- ▶ Are familiar with the basic regulations concerning health and safety / accident prevention,
- ▶ Have read and understood the information provided in the section entitled Safety
- ▶ Have a good knowledge of the generic and specialist standards applicable to the specific application.

Warranty and liability

All claims to warranty and liability will be rendered invalid if

- ▶ The product was used contrary to the purpose for which it is intended,
- ▶ Damage can be attributed to not having followed the guidelines in the manual,
- ▶ Operating personnel are not suitably qualified,
- ▶ Any type of modification has been made (e.g. exchanging components on the PCB boards, soldering work etc.).

Disposal

- ▶ In safety-related applications, please comply with the mission time T_M stated in the safety-related characteristic data.
- ▶ When decommissioning, please comply with local regulations regarding the disposal of electronic devices (e.g. Electrical and Electronic Equipment Act).

For your safety

The unit meets all the necessary conditions for safe operation. However, please note the following:

- ▶ Note for overvoltage category III: If voltages higher than low voltage (>50 VAC or >120 VDC) are present on the unit, connected control elements and sensors must have a rated insulation voltage of at least 250 V.

Unit features

- ▶ Positive-guided relay outputs:
 - 4 safety contacts (N/O), delay-on de-energisation
- ▶ 1 semiconductor output for variable frequency inverter
- ▶ Connection options for:
 - E-STOP pushbutton
 - Safety gate limit switch
 - Start button
- ▶ LED display for:
 - Supply voltage
 - Switch state of the safety contacts
 - State of semiconductor output
- ▶ Delay time can be switched off

Safety features

The safety relay meets the following safety requirements:

- ▶ The circuit is redundant with built-in self-monitoring.
- ▶ The safety function remains effective in the case of a component failure.
- ▶ The correct opening and closing of the safety function relays is tested automatically in each on-off cycle.

Block diagram/terminal configuration

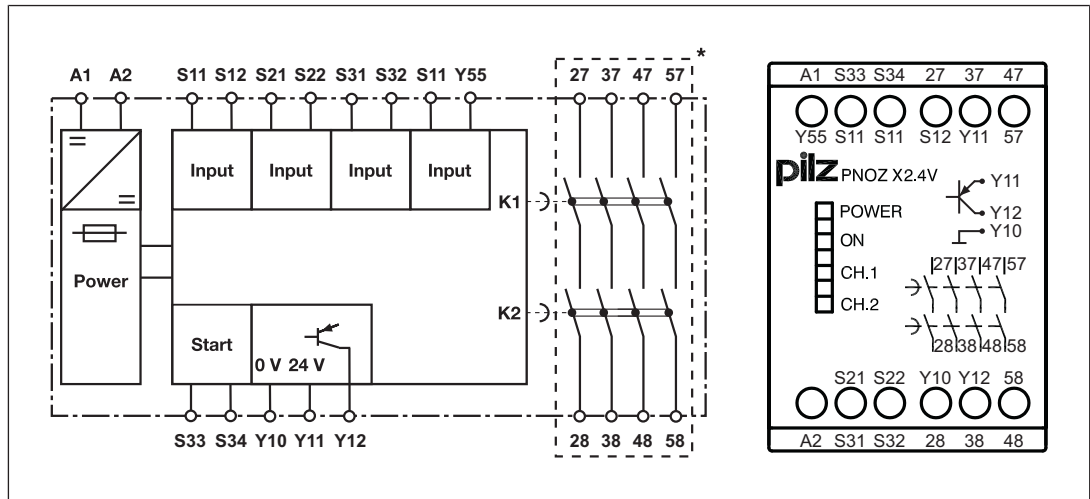

*Insulation between the non-marked area and the relay contacts: Basic insulation (over-voltage category III), Protective separation (overvoltage category II)

Function Description

The safety relay PNOZ X2.4V provides a safety-oriented interruption of a safety circuit. When supply voltage is supplied the "POWER" LED is lit. The unit is ready for operation when the start circuit S33-S34 is closed.

- ▶ Input circuit is closed (e.g. E-STOP pushbutton not operated):
 - The LEDs "CH.1" and "CH.2" are lit.
 - The safety contacts 27-28, 37-38, 47-48 and 57-58 are closed. The unit is active.
 - A high signal is present at semiconductor output Y12.
 - The "ON" LED is lit.
- ▶ Input circuit is opened (e.g. E-STOP pushbutton operated):
 - A low signal is present at semiconductor output Y12.
 - The "ON" LED goes out.
 - Safety contacts 27-28, 37-38, 47-48 and 57-58 open after the delay time has elapsed.
 - The LEDs "CH.1" and "CH.2" go out.

Operating modes

- ▶ Single-channel operation: No redundancy in the input circuit, earth faults in the start and input circuit are detected.
- ▶ Dual-channel operation with detection of shorts across contacts: Redundant input circuit, PNOZ X2.4V detects
 - earth faults in the start and input circuit,
 - short circuits in the input circuit,
 - shorts across contacts in the input circuit.
- ▶ Automatic start: Unit is active once the input circuit has been closed.
- ▶ Manual start: Unit is active once the input circuit and the start circuit are closed.
- ▶ Increase in the number of available contacts by connecting contact expansion modules or external contactors/relays.



NOTICE

The device does not recognise short circuits or shorts across contacts in the start/feedback loop. Take suitable measures, such as fault exclusion through protected or separate installation.

Timing diagram

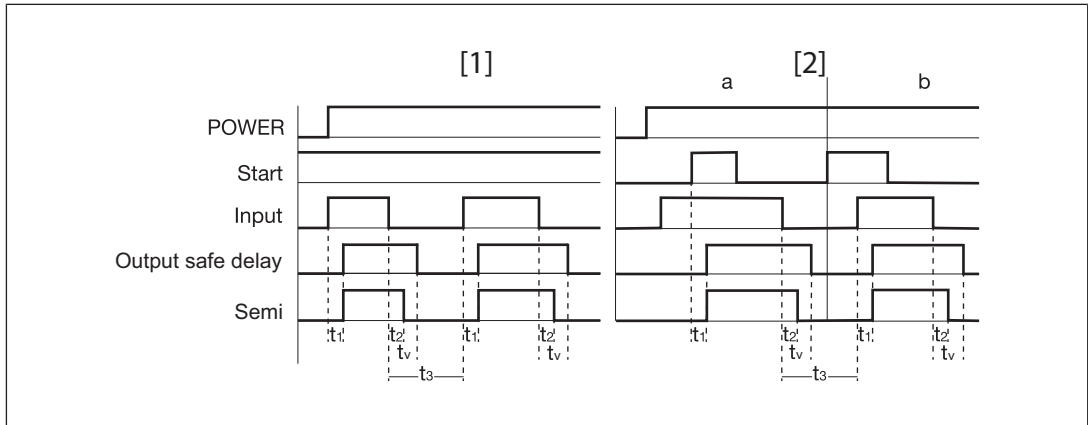

Legend

- ▶ Power: Supply voltage
- ▶ Start: Start circuit
- ▶ Input: Input circuit
- ▶ Output safe delay: Safety contacts, delayed
- ▶ Semi: Semiconductor output
- ▶ [1]: Automatic start
- ▶ [2]: Manual start
- ▶ a: Input circuit closes before start circuit
- ▶ b: Start circuit closes before input circuit
- ▶ t_1 : Switch-on delay
- ▶ t_2 : Delay-on de-energisation
- ▶ t_3 : Recovery time
- ▶ t_v : Delay time



NOTICE

In the case of a fault, the delay-on de-energisation safety contacts open after the set delay time + 100% of the set value, at the latest. An earlier shutdown is possible. For this reason, safety functions that require a minimum delay time must not be implemented.

Installation



NOTICE

Protection against manipulation

Protect the product from unauthorised access.

- ▶ The unit should be installed in a control cabinet with a protection type of at least IP54.
- ▶ Use the notch on the rear of the unit to attach it to a DIN rail (35 mm).
- ▶ When installed vertically: secure the unit by using a fixing element (e.g. retaining bracket or end angle).

Wiring

Please note:

- ▶ Information given in the "[Technical details \[16\]](#)" must be followed.
- ▶ Outputs 27-28, 37-38, 47-48 and 57-58 are delay-on de-energisation safety contacts.
- ▶ Semiconductor output Y12 should **not** be used for safety circuits!
- ▶ Do not connect undesignated terminals.
- ▶ To prevent contact welding, a fuse should be connected before the output contacts (see [Technical details \[16\]](#)).
- ▶ Calculation of the max. cable length l_{\max} in the input circuit:

$$l_{\max} = \frac{R_{l_{\max}}}{R_l / \text{km}}$$

$R_{l_{\max}}$ = max. overall cable resistance (see [Technical details \[16\]](#))

R_l / km = cable resistance/km

- ▶ Use copper wiring with a temperature stability of 60/75 °C.
- ▶ To prevent EMC interferences (particularly common-mode interferences) the measures described in EN 60204-1 must be executed. This includes the separate routing of cables of the control circuits (input, start and feedback loop) from other cables for energy transmission or the shielding of cables, for example.
- ▶ Do not switch low currents using contacts that have been used previously with high currents.
- ▶ Adequate protection circuit must be provided on all output contacts with capacitive and inductive loads.
- ▶ The power supply must comply with the regulations for extra low voltages with protective electrical separation (SELV, PELV) in accordance with VDE 0100, Part 410.
- ▶ Semiconductor output supply voltage: Connect surge protection elements between the Y10 and Y11 connections and any DC distribution network (not SELV/PELV) fed from outside of the electrical installation area.

Important for detection of shorts across contacts:

As this function for detecting shorts across contacts is not failsafe, it is tested by Pilz during the final control check. If there is a danger of exceeding the cable runs, we recommend the following test after the installation of the device:

1. Unit ready for operation (output contacts closed)
2. Short circuit the test terminals S12, S22 for detecting shorts across the inputs.
3. The unit's fuse must be triggered and the output contacts must open. Cable lengths in the scale of the maximum length can delay the fuse triggering for up to 2 minutes.
4. Reset the fuse: remove the short circuit and switch off the supply voltage for approx. 1 minute.

Preparing for operation

Supply voltage	AC	DC
Input circuit	Single-channel	Dual-channel
E-STOP without detection of shorts across contacts		
E-STOP with detection of shorts across contacts		
Safety gate with detection of shorts across contacts		



NOTICE

With single-channel wiring, the safety level of your plant/machine may be lower than the safety level of the unit (see [Safety characteristic data \[19\]](#)). To achieve the stated safety level, appropriate measures must be taken on single-channel applications to exclude faults in the input circuit. Examples of such measures are: protected cable routing and positive-opening contacts in the E-STOP pushbutton.

Start circuit	Automatic start	Manual start



NOTICE

In the event of an automatic start or manual start with bridged start contact (fault):

The unit starts up automatically when the safeguard is reset, e.g. when the E-STOP pushbutton is released. Use external circuit measures to prevent an unexpected restart.

Delay time	Delayed	Instantaneous
Delay time 1 s or instantaneous		Without link S11-Y55
Feedback loop	Automatic start	Manual start
Contacts from external contactors		
Semiconductor output		

Legend

- ▶ S1/S2: E-STOP/safety gate switch
- ▶ S3: Reset button
- ▶ ⤴: Switch operated
- ▶ : Gate open
- ▶ : Gate closed

Application example

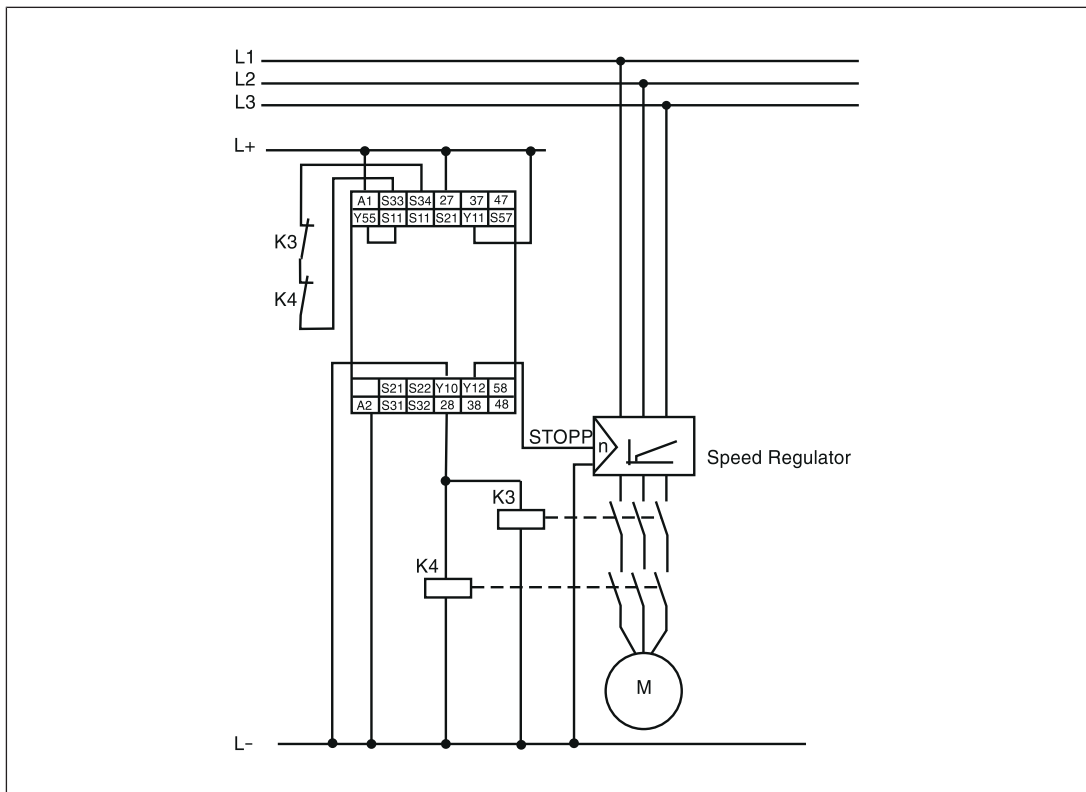

Fig.: Variable frequency inverter with semiconductor output

Operation

When the relay outputs are switched on, the mechanical contact on the relay cannot be tested automatically. Depending on the operational environment, measures to detect the non-opening of switching elements may be required under some circumstances.

When the product is used in accordance with the European Machinery Regulation, a check must be carried out to ensure that the safety contacts on the relay outputs open correctly. Open the safety contacts (switch off output) and start the device again for SIL 2/PL d at least 1 x per year, so that the internal diagnostics can check that the safety contacts open correctly.





NOTICE

The safety functions should be checked after initial commissioning and each time the plant/machine is changed. The safety functions may only be checked by qualified personnel.

Status indicators

LEDs indicate the status and errors during operation:

-  LED on

-  **POWER**
 Supply voltage is present.

-  **ON**
 Semiconductor output is active.

-  **CH.1**
 Safety contacts of channel 1 are closed.

-  **CH.2**
 Safety contacts of channel 2 are closed.

Faults – Interference

- ▶ Earth fault: The supply voltage fails and the safety contacts open. Once the cause of the respective fault has been rectified and the supply voltage is switched off for approx. 1 minute, the unit is ready for operation again.
- ▶ Contact malfunctions: If the contacts have welded, reactivation will not be possible after the input circuit has opened.
- ▶ LED "POWER" does not light: Short circuit or no supply voltage.
- ▶ In the case of an error, the delay-on de-energisation contacts may open before the delay time has elapsed.

Dimensions in mm

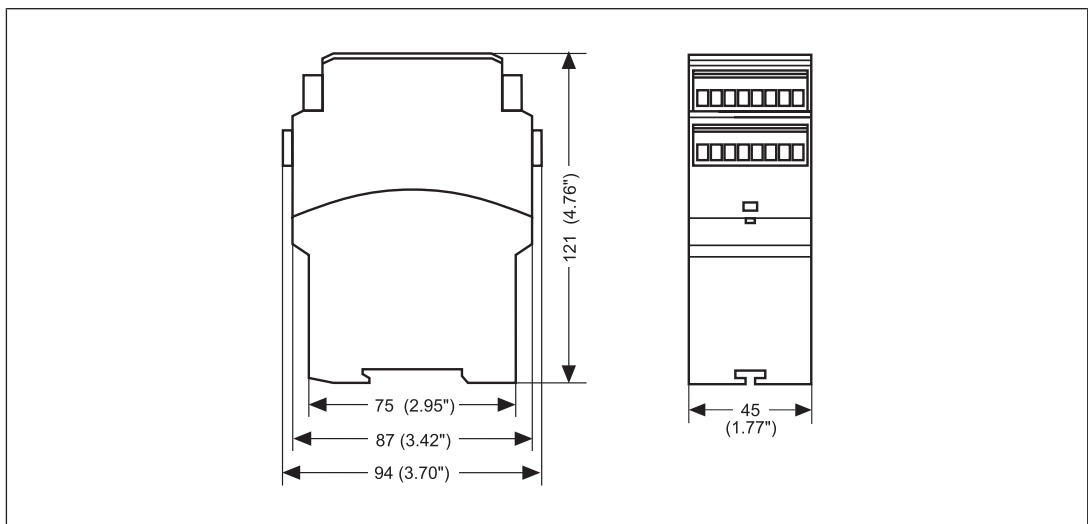

Technical details

Where standards are undated, the 2022-09 valid editions apply.

General	
Certifications	CCC, CE, EAC, TÜV, UKCA
Electrical data	
Supply voltage	
Voltage	24 V
Kind	DC
Voltage tolerance	-15 %/+10 %
Output of external power supply (DC)	2 W
Residual ripple DC	20 %
Duty cycle	100 %
Max. inrush current impulse	
Current pulse, A1	1,5 A
Pulse duration, A1	0,2 ms
Inputs	
Quantity	2
Voltage at	
Input circuit DC	24 V
Start circuit DC	24 V
Feedback loop DC	24 V
Current at	
Input circuit DC	50 mA
Start circuit DC	50 mA
Feedback loop DC	50 mA
Max. overall cable resistance R _{lmax}	
Single-channel at UB DC	100 Ohm
Dual-channel with detection of shorts across contacts at UB DC	30 Ohm
Semiconductor outputs	
Quantity	1
Voltage	24 V
Current	50 mA
External supply voltage	24 V
Voltage tolerance	-20 %/+20 %
Residual current at "0" signal	0,1 mA
Max. internal voltage drop	4 V
Conditional rated short circuit current	100 A
Lowest operating current	0 mA
Utilisation category in accordance with EN 60947-1	DC-12
Relay outputs	
Number of output contacts	
Safety contacts (N/O), delayed	4

Relay outputs

Max. short circuit current IK	1 kA
Utilisation category	
in accordance with the standard	EN 60947-4-1
Utilisation category of safety contacts	
AC1 at	240 V
Min. current	0,01 A
Max. current	6 A
Max. power	1.500 VA
DC1 at	24 V
Min. current	0,01 A
Max. current	6 A
Max. power	150 W
Utilisation category	
in accordance with the standard	EN 60947-5-1
Utilisation category of safety contacts	
AC15 at	230 V
Max. current	5 A
DC13 (6 cycles/min) at	24 V
Max. current	5 A
External contact fuse protection, safety contacts	
in accordance with the standard	EN 60947-5-1
Max. melting integral	240 A²s
Blow-out fuse, quick	6 A
Blow-out fuse, slow	4 A
Blow-out fuse, gG	6 A
Circuit breaker 24V AC/DC, characteristic B/C	4 A
Contact material	AgSnO₂ + 0,2 µm Au

Conventional thermal current while loading several contacts

Ith per contact at UB DC; AC1: 240 V, DC1: 24 V

Conv. therm. current with 1 contact	6 A
Conv. therm. current with 2 contacts	5,5 A
Conv. therm. current with 3 contacts	4,6 A
Conv. therm. current with 4 contacts	4 A

Times

Switch-on delay	
with automatic start typ.	100 ms
with automatic start max.	200 ms
with automatic start after power on typ.	100 ms
with automatic start after power on max.	220 ms
with manual start typ.	30 ms
with manual start max.	50 ms

Times

Delay-on de-energisation	
with E-STOP typ.	30 ms
with E-STOP max.	60 ms
with power failure typ.	30 ms
with power failure max.	100 ms

Recovery time at max. switching frequency 1/s	
after E-STOP	1000 ms +tv
after power failure	1000 ms

Delay time tv	1 s
Time accuracy	-30 %/+100 %
Supply interruption before de-energisation	10 ms
Simultaneity, channel 1 and 2 max.	∞

Environmental data

Climatic suitability	EN 60068-2-78
----------------------	----------------------

Ambient temperature	
Temperature range	-10 - 55 °C

Storage temperature	
Temperature range	-40 - 85 °C

Climatic suitability	
Humidity	93 % r. h. at 40 °C

Condensation during operation	Not permitted
-------------------------------	----------------------

EMC	EN 60947-5-1, EN 61000-6-2, EN 61326-3-1
-----	---

Vibration	
in accordance with the standard	EN 60068-2-6
Frequency	10 - 55 Hz
Amplitude	0,35 mm

Airgap creepage	
in accordance with the standard	EN 60947-1
Overvoltage category	III / II
Pollution degree	2

Rated insulation voltage	250 V
--------------------------	--------------

Rated impulse withstand voltage	4 kV
---------------------------------	-------------

Protection type	
Housing	IP40
Terminals	IP20
Mounting area (e.g. control cabinet)	IP54

Mechanical data

Mounting position	Any
Mechanical life	10,000,000 cycles

Material	
Bottom	PPO UL 94 V1
Front	ABS UL 94 V0
Top	PPO UL 94 V1

Connection type	Screw terminal
-----------------	-----------------------

Mechanical data

Mounting type	Fixed
Conductor cross section with screw terminals	
1 core flexible	0,2 - 4 mm², 24 - 10 AWG
2 core with the same cross section, flexible with crimp connectors, no plastic sleeve	0,2 - 2,5 mm², 24 - 14 AWG
2 core with the same cross section, flexible without crimp connectors or with TWIN crimp connectors	0,2 - 2,5 mm², 24 - 14 AWG
Torque setting with screw terminals	0,5 Nm
Stripping length with screw terminals	6 mm
Dimensions	
Height	87 mm
Width	45 mm
Depth	121 mm
Weight	290 g

Safety characteristic data



NOTICE

You must comply with the safety characteristic data in order to achieve the required safety level for your plant/machine.

Operating mode	EN ISO 13849-1: 2023	EN ISO 13849-1: 2023	EN IEC 62061 SIL CL/max.	EN IEC 62061 61508	EN/IEC 61511 61508	EN/IEC 61511 61508	EN ISO 13849-1: 2023
	PL	Category	SIL	PFH [1/h]	SIL	PFD	T _M [year]

Safety contacts, delayed <30 s

PL d	Cat. 3	SIL 2	3,98E-09	SIL 2	1,32E-04	20
-------------	---------------	--------------	-----------------	--------------	-----------------	-----------

Explanatory notes for the safety-related characteristic data:

- ▶ T_M is the maximum mission time in accordance with EN ISO 13849-1. The value also applies as the retest interval in accordance with EN IEC 61508-6 and EN IEC 61511 and as the proof test interval and mission time in accordance with EN IEC 62061.

All the units used within a safety function must be considered when calculating the safety characteristic data.



INFORMATION

A safety function's SIL/PL values are **not** identical to the SIL/PL values of the products used and may differ from these.

Supplementary data



CAUTION!

It is essential to consider the relay's service life graphs. The relay outputs' safety-related characteristic data is only valid if the values in the service life graphs are met.

The PFH value depends on the switch frequency and the load of the relay output. If the service life graphs are not accessible, the stated PFH value can be used irrespective of the switch frequency and the load, as the PFH value already considers the relay's B10d value as well as the failure rates of the other components.

Service life graph

The service life graphs indicate the number of cycles from which failures due to wear must be expected. The wear is mainly caused by the electrical load; the mechanical load is negligible.

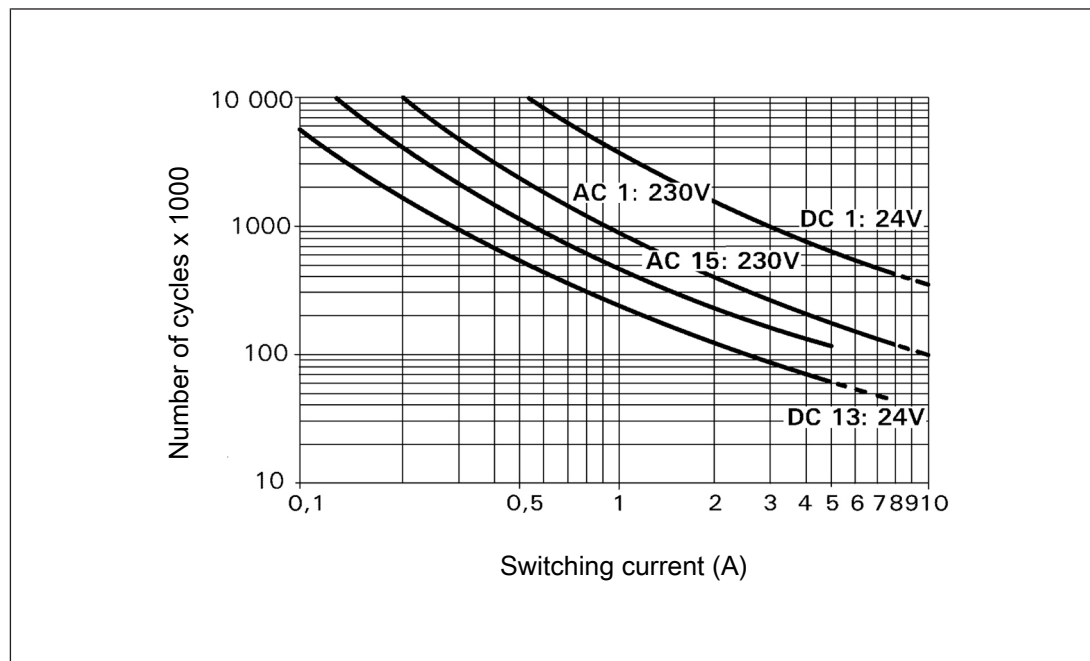

Example

- ▶ Inductive load: 0.2 A
- ▶ Utilisation category: AC15
- ▶ Contact service life: 4 000 000 cycles

Provided the application to be implemented requires fewer than 4 000 000 cycles, the PFH value (see Technical details) can be used in the calculation.

To increase the service life, sufficient spark suppression must be provided on all output contacts. With capacitive loads, any power surges that occur must be noted. With DC contactors, use flywheel diodes for spark suppression.

Order reference

Product type	Features	Connection type	Product ID
PNOZ X2.4V	24 VDC	Screw terminals	774517

EU/EC declaration of conformity

These products meet the requirements of the directive 2006/42/EC on machinery up to and including 19 January 2027, and the EU regulation 2023/1230 of the European Parliament and of the Council from 20 January 2027. The full EU and EC declaration of conformity is available to download at www.pilz.com/manuals.

Authorised representative: Pilz GmbH & Co. KG, Felix-Wankel-Str. 2, 73760 Ostfildern, Germany

UKCA-Declaration of Conformity

These products comply with following UK legislation: Supply of Machinery (Safety) Regulation 2008.

The complete UKCA Declaration of Conformity is available on the Internet at www.pilz.com/manuals.

Representative: Pilz Automation Technology, Pilz House, Little Colliers Field, Corby, Northamptonshire, NN18 8TJ United Kingdom, eMail: mail@pilz.co.uk

Support

Technical support is available from Pilz round the clock.

Americas

Brazil

+55 11 97569-2804

Canada

+1 888 315 7459

Mexico

+52 55 5572 1300

USA (toll-free)

+1 877-PILZUSA (745-9872)

Asia

China

+86 400-088-3566

Japan

+81 45 471-2281

South Korea

+82 31 778 3390

Australia and Oceania

Australia

+61 3 95600621

New Zealand

+64 9 6345350

Europe

Austria

+43 1 7986263-444

Belgium, Luxembourg

+32 9 3217570

France

+33 3 88104003

Germany

+49 711 3409-444

Ireland

+353 21 4804983

Italy, Malta

+39 0362 1826711

Scandinavia

+45 74436332

Spain

+34 938497433

Switzerland

+41 62 88979-32

The Netherlands

+31 347 320477

Türkiye

+90 216 5775552

United Kingdom

+44 1536 460866

You can reach our international hotline on:

+49 711 3409-222

support@pilz.com

Reporting security vulnerabilities or security incidents

If you would like to report a security vulnerability or a security incident in connection with a Pilz product, please contact our **Pilz Product Security Incident Response Team (PSIRT)**.

You can reach us at: www.pilz.com/psirt

Pilz develops environmentally-friendly products using ecological materials and energy-saving technologies. Offices and production facilities are ecologically designed, environmentally-aware and energy-saving. So Pilz offers sustainability, plus the security of using energy-efficient products and environmentally-friendly solutions.



www.pilz.com/facebook



www.pilz.com/linkedin



www.pilz.com/xing



www.pilz.com/youtube



We are represented internationally. Please refer to our homepage www.pilz.com for further details or contact our headquarters.

Headquarters: Pilz GmbH & Co. KG, Felix-Wankel-Straße 2, 73760 Ostfildern, Germany
Telephone: +49 711 3409-0, E-Mail: info@pilz.com, Internet: www.pilz.com

PILZ
THE SPIRIT OF SAFETY

20219-EN-12, 2026-03 Printed in Germany
© Pilz GmbH & Co. KG, 2024
CECE, CHRE, CMSE®, IndustrialPi®, Leansate®, MYZEL®, PAS4000®, PAScal®, PASconfig®, Pilz®, PII®, PMCprimo®, PMCprotego®, PMCTendo®, PMD®, PMI®, PNOZ®, Primo®, PSEN®, PSS®, PVS®, SafetyBUS p®, SafetyNET p®, THE SPIRIT OF SAFETY® are registered and protected trademarks of Pilz GmbH & Co. KG in some countries. We would point out that product features may vary from the details stated in this document, depending on the status at the time of publication and the scope of the equipment. We accept no responsibility for the validity, accuracy and entirety of the text and graphics presented in this information. Please contact our Technical Support if you have any questions.