

► High availability with complete flexibility

Presses

Guaranteed safety coupled with high availability and complete flexibility – the demands on the automation of single presses and press lines are becoming increasingly complex. Pilz will help you equip, upgrade and operate your system with the latest in safety technology.

Safety solutions and concepts for all types of press

Operators and maintenance personnel have direct access to the danger zone of a press, so a continuous safety concept is essential. Production cycles must run smoothly in order to guarantee economic efficiency, even on the smallest of loads. When it comes to a holistic, cost-optimised all-in-one solution from safe sensor technology to control systems and drive technology, Pilz is the right partner for you.

- Solutions for all types of press, from the manually operated single workstation to the fully automated press line
- Customised, long-lasting all-in-one solutions with products specially developed for the press industry
- Safety-related redesign and retrofit of old presses
- Services from risk assessment to verification of safety solutions and CE marking

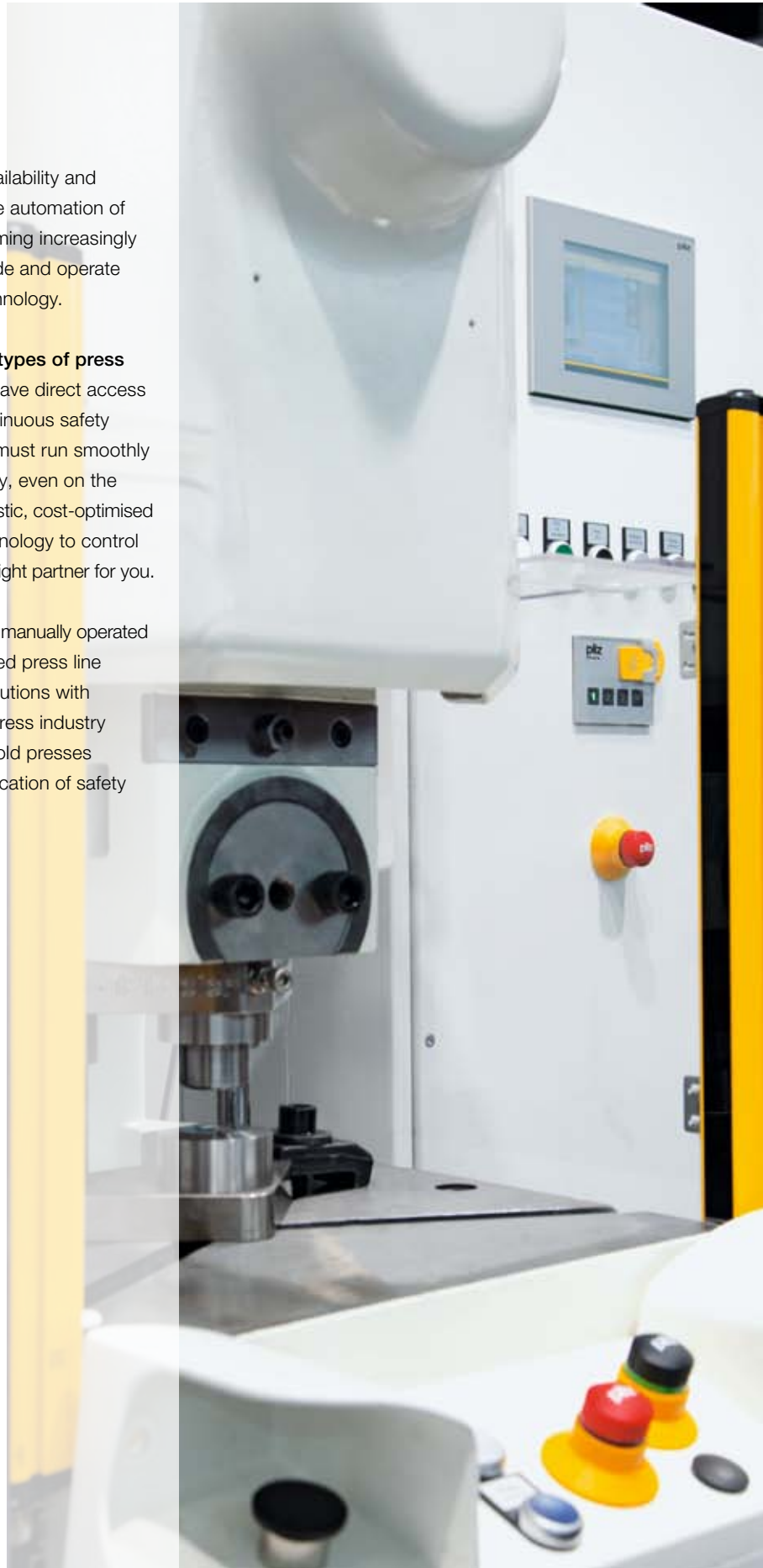

► Safety-related equipment, upgrade and operation

Reliable safety technology for presses should not only be flexible and powerful, but economical too. When it comes to a holistic, all-in-one solution from safe sensor technology to control systems and drive technology, Pilz is the right partner for you.

Optoelectronic protective devices PSENOpt

Where operator intervention is required in each cycle, the safety light grids and light curtains PSENOpt help you work efficiently and ergonomically. The Fast Control Unit allows shorter safety distances for light curtains in the automation system PSS 4000.

The fast, productive solution for press brakes: PSS 4000 FAST and PSEnvip

Need to be able to shut down quickly, yet remain productive? That's a simple matter with the Fast Control Unit in the automation system PSS 4000 and the camera-based protection system PSEnvip. The local "intelligence" of the I/O module enables fast signal processing – which means that even drives and valves can be shut down quickly, reducing the overall reaction time. As a mobile protection system, PSEnvip detects even fingertips in the protected field between transmitter and receiver. The innovative LED technology guarantees a high level of machine availability and is robust to vibration, light and temperature.



Fast Control Unit: for rapid switching operations

When docked into the control unit PSSuniversal PLC or PSSuniversal multi, the Fast Control Unit in the automation system PSS 4000 enables local safe inputs to be switched to the outputs with little loss of time. Particularly short and time-critical signals can also be read in.

Safe motion enhances safety and productivity

Presses with a servo drive increase the output rate and provide maximum flexibility. The Pilz safe motion solution is ideal for achieving the necessary safety level. Functions such as "Safely Limited Speed" in setup mode, "Safe Direction" during the opening phase and "Safe Brake Control" enable operators to work safely within the danger zone.

Your benefits at a glance

- Reaction times are even faster
- Productivity increased by up to 50 %
- Fast valve shutdown enables safe work practices
- High flexibility and speed thanks to local intelligence.
- Setup times reduced to a minimum

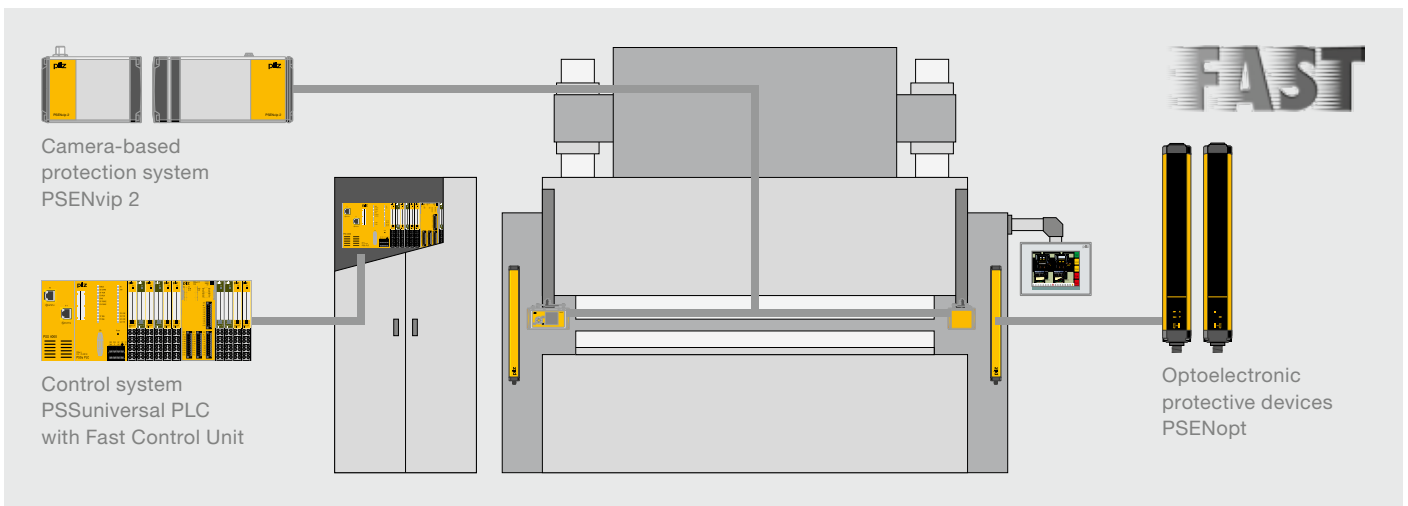

of presses

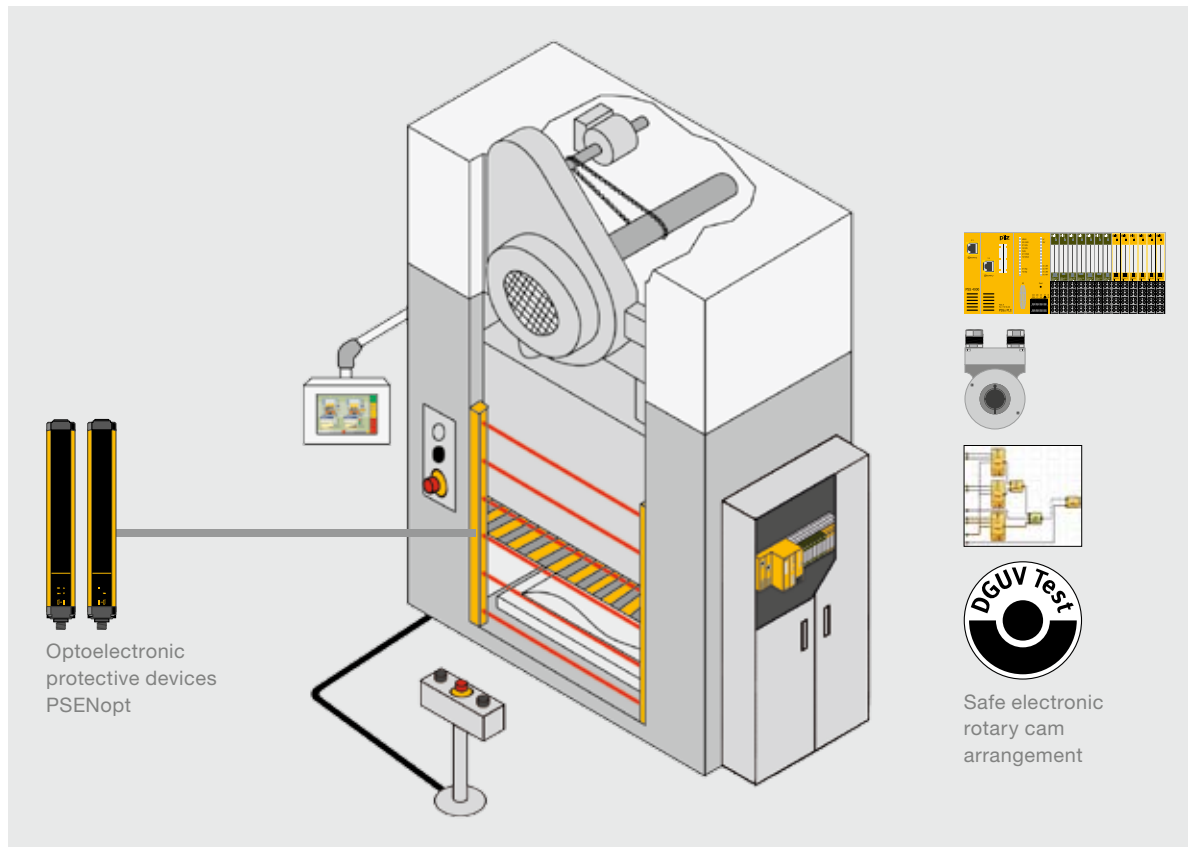

The optimum solution for a universal control system for mechanical presses: PSS 4000 – safe electronic rotary cam arrangement

The optimum solution for a universal control system for mechanical presses: the safe electronic rotary cam arrangement PSS 4000. The solution consists of the control system PSSuniversal PLC, press blocks (CamController) and the rotary encoder PSENenco. This solution replaces conventional mechanical rotary cam arrangements. The combination will really make you productive: the rotary encoder transmits the current encoder values to the PSSuniversal PLC. The software program calculates the working angle that allows press solutions to be realised safely, flexibly and economically, from dynamisation of the TDC cam to internal monitoring for broken shearpins. There is no need for time-consuming adjustment of the switch cams.

The shutdown cam for presses with a variable number of strokes can be calculated safety and dynamically. The overrun is automatically recalculated every time the press stops, which means that the press is always guaranteed to stop at exactly the right point. The press is blocked if the set thresholds are exceeded.

Your benefits at a glance

- ▶ Safe cams for run-up, overrun and shutdown with dynamisation for a safe stop at TDC with a variable number of strokes
- ▶ Continuous overrun measurement to minimise down times
- ▶ Supports stroke length adjustment by adopting the electrical angle
- ▶ Excellent manipulation protection
- ▶ Approved safety solution in accordance with EN 692

Further information on the subject of presses:

 Webcode 1061

► Retrofit to use older machines for longer

Presses tend to have a longer service life than other machines. After many years of use they often do not deliver the required reliability and performance. Safety deficiencies can also occur. While the mechanical components are still completely intact, the control and drive technology may now be outdated. A retrofit brings your press back up to the state of the art, delivering a significant boost to productivity and safety and also contributing to improvements in energy efficiency.

We'll do it for you!

Pilz can undertake all the engineering involved in upgrading your old press – from generation of the circuit diagrams and control program through to commissioning and approval. We will make your press safe in accordance with applicable international standards and bring your control and drive technology up to the state of the art.

Your benefits at a glance

- ▶ Enhanced productivity through the use of cutting-edge technology
- ▶ Reduction in standstill and downtimes
- ▶ Approved safety concepts in accordance with international norms and standards
- ▶ Improved energy efficiency through the use of the latest servo motors in drive technology (PMcTendo SZ up to 20 % more efficient than IE3)
- ▶ Rapid amortisation, as production becomes smooth and trouble-free again
- ▶ Much lower costs than for a new investment

Energy
saving by Pilz



Further information on the subject of presses:

 Webcode 1061

Online information at www.pilz.com/presses

► Services to cover the entire machine lifecycle

As a solution supplier, Pilz can help you implement the relevant standards and directives and develop an optimum safety strategy for your presses worldwide. The range of services encompasses the whole machine lifecycle and is complemented by a training package with practical, up-to-date content.

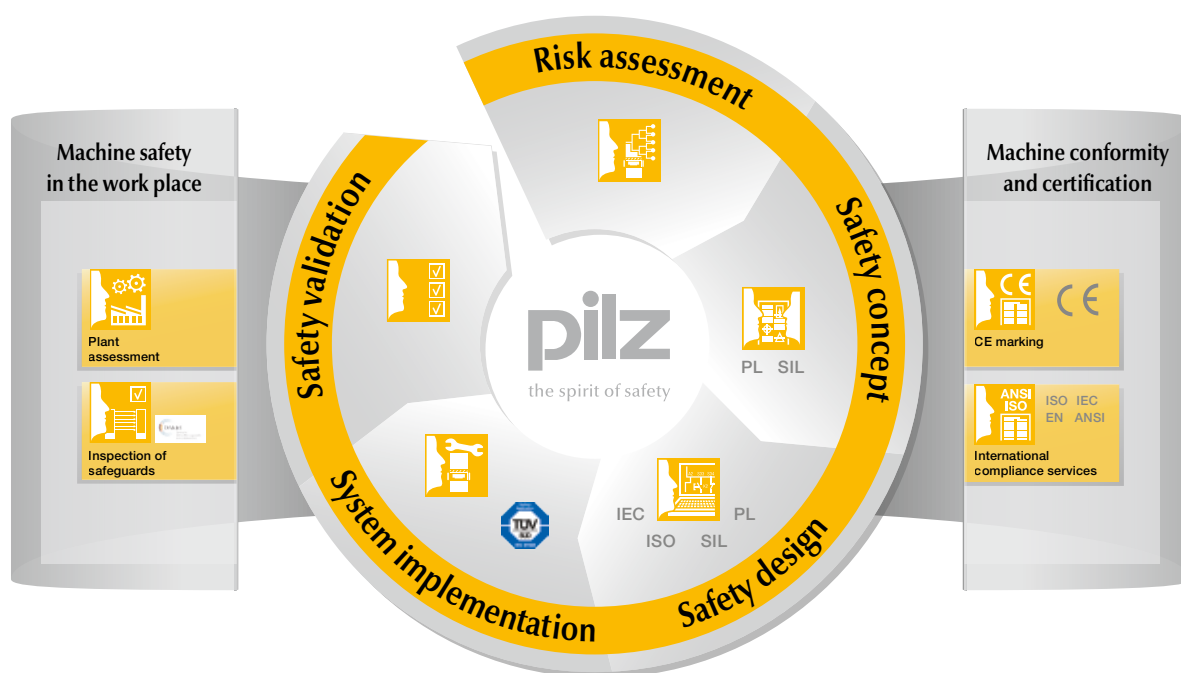

Risk assessment

We inspect your machinery in accordance with the applicable national and/or international standards and directives and assess the existing hazards.



Safety validation

In the safety validation, the risk assessment and safety concept are mirrored and inspected by competent, specialist staff.



Safety concept

We develop detailed technical solutions for the safety of your plant and machinery through mechanical, electronic and organisational measures.



CE marking

We control all activities and processes for the necessary conformity assessment procedure, including the technical documentation that is required.



System implementation

The results of the risk analysis and safety design are implemented to suit the particular requirements through selected safety measures.



Hazard assessment

We develop precise, tailor-made solution proposals based on our structured hazard assessment.

Services related to machine safety:

Webcode 7792

Knowledge is a competitive edge – Pilz training courses:

Webcode 0218

► Support

Technical support is available from Pilz round the clock.

Americas

Brazil
+55 11 97569-2804

Canada
+1 888-315-PILZ (315-7459)

Mexico
+52 55 5572 1300

USA (toll-free)
+1 877-PILZUSA (745-9872)

Asia

China
+86 21 60880878-216

Japan
+81 45 471-2281

South Korea
+82 31 450 0680

Australia

+61 3 95446300

Europe

Austria
+43 1 7986263-0

Belgium, Luxembourg
+32 9 3217575

France
+33 3 88104000

Germany
+49 711 3409-444

Ireland
+353 21 4804983

Italy
+39 0362 1826711

Scandinavia

+45 74436332

Spain

+34 938497433

Switzerland

+41 62 88979-30

The Netherlands

+31 347 320477

Turkey

+90 216 5775552

United Kingdom

+44 1536 462203

You can reach our international hotline on:

+49 711 3409-444
support@pilz.com

Pilz develops environmentally-friendly products using ecological materials and energy-saving technologies. Offices and production facilities are ecologically designed, environmentally-aware and energy-saving. So Pilz offers sustainability, plus the security of using energy-efficient products and environmentally-friendly solutions.

Energy saving by Pilz



The 4-fold safety of automation



Presented by:



Pilz GmbH & Co. KG
Felix-Wankel-Straße 2
73760 Ostfildern, Germany
Tel.: +49 711 3409-0
Fax: +49 711 3409-133
info@pilz.com
www.pilz.com

pilz
the spirit of safety